

COMPUTING DEGRADATION AND LOCAL SCOUR

**TECHNICAL GUIDELINE FOR
BUREAU OF RECLAMATION**

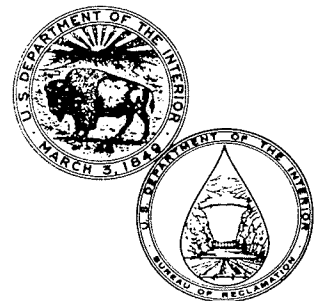

TECHNICAL REPORT STANDARD TITLE PAGE

1. REPORT NO.	2. GOVERNMENT ACCESSION NO.	3. RECIPIENT'S CATALOG NO.
4. TITLE AND SUBTITLE Computing Degradation and Local Scour	5. REPORT DATE January 1984	6. PERFORMING ORGANIZATION CODE
	7. AUTHOR(S) Ernest L. Pemberton and Joseph M. Lara	8. PERFORMING ORGANIZATION REPORT NO.
9. PERFORMING ORGANIZATION NAME AND ADDRESS Bureau of Reclamation Engineering and Research Center Denver, Colorado 80225	10. WORK UNIT NO.	11. CONTRACT OR GRANT NO.
	12. SPONSORING AGENCY NAME AND ADDRESS Same	13. TYPE OF REPORT AND PERIOD COVERED Technical Guideline
15. SUPPLEMENTARY NOTES Microfiche and/or hard copy available at the Engineering and Research Center, Denver, Colorado	14. SPONSORING AGENCY CODE DIBR	Editor-JMT
	16. ABSTRACT Several methods are presented in this technical guide, which can be applied to estimate degradation of a stream channel, occurring because of changes in flow regimen or reduced sediment load below a dam or diversion structure. Estimation of degradation include two types: Those limited by channel armoring and degradation limited by a stable slope. Detailed procedures are introduced to use in estimating maximum scour depth of channels at bridges or siphon crossings.	
17. KEY WORDS AND DOCUMENT ANALYSIS a. DESCRIPTORS-- / stream degradation/ critical tractive force/ deposition/ scour/ streambeds/ stream erosion/ bed load/ hydraulic structures b. IDENTIFIERS-- / channels/ sedimentation/ erosion c. COSATI Field/Group 08H, 13B COWRR: 0808 SRIM: 48G, 50B		
18. DISTRIBUTION STATEMENT Available from the National Technical Information Service, Operations Division, 5285 Port Royal Road, Springfield, Virginia 22161. (Microfiche and/or hard copy available from NTIS)	19. SECURITY CLASS (THIS REPORT) UNCLASSIFIED	21. NO. OF PAGES 48
	20. SECURITY CLASS (THIS PAGE) UNCLASSIFIED	22. PRICE

COMPUTING
DEGRADATION AND
LOCAL SCOUR

by

Ernest L. Pemberton
Joseph M. Lara

TECHNICAL GUIDELINE FOR
BUREAU OF RECLAMATION



SEDIMENTATION AND RIVER HYDRAULICS SECTION
HYDROLOGY BRANCH
DIVISION OF PLANNING TECHNICAL SERVICES
ENGINEERING AND RESEARCH CENTER

DENVER, COLORADO

JANUARY 1984

As the Nation's principal conservation agency, the Department of the Interior has responsibility for most of our nationally owned public lands and natural resources. This includes fostering the wisest use of our land and water resources, protecting our fish and wildlife, preserving the environmental and cultural values of our national parks and historical places, and providing for the enjoyment of life through outdoor recreation. The Department assesses our energy and mineral resources and works to assure that their development is in the best interests of all our people. The Department also has a major responsibility for American Indian reservation communities and for people who live in Island Territories under U.S. Administration.

The information contained in this report regarding commercial products or firms may not be used for advertising or promotional purposes and is not to be construed as an endorsement of any product or firm by the Bureau of Reclamation.

The information contained in this report was developed for the Bureau of Reclamation; no warranty as to the accuracy, usefulness, or completeness is expressed or implied.

CONTENTS

	<u>Page</u>
Introduction	1
Background on degradation	1
General degradation	3
Basic factors influencing degradation	3
Bed material sampling	4
Hydraulic properties	6
Degradation limited by armoring	9
Meyer-Peter, Muller (bedload transport equation)	9
Competent bottom velocity	10
Lane's tractive force	10
Shields diagram	12
Yang incipient motion	12
Depth to armor and volume computations	14
Degradation limited by a stable slope	17
Schoklitsch method	18
Meyer-Peter, Muller method	18
Shields diagram method	18
Lane's tractive force method	19
Example of the stable slope computations	19
Volume computations	22
Channel scour during peak floodflows	29
Design flood	31
Equation types A and B (see table 6)	32
Field measurements of scour method	32
Regime equations supported by field measurements method	34
Mean velocity from field measurements method	37
Competent or limiting velocity control to scour method	38
Equation type C (see table 6)	40
Equation type D (see table 6)	40
Example problem	42
Conclusions	43
References	45

TABLES

<u>Table</u>	<u>Page</u>	
1	Conversion of rock count (grid-by-number) to sieve analysis by weight - sample No. B-2 Colorado River below Glen Canyon Dam - 1975	6
2	Stable slope	22
3	Comparison of Fortier and Scobey's limiting velocities with tractive force values	26
4	Sinuosity correction for canals	27
5	Degraded width computations by tractive force	28
6	Classification of scour equation for various structure designs	31
7	Multiplying factors, Z, for use in scour depths by regime equations	36
8	Tentative guide to competent velocities for erosion of cohesive materials (after Neill, 1973)	38
9	Example problem - Salt River scour study below Granite Reef Diversion Dam	44
10	Summary of channel scour during a floodflow on Salt River	43

FIGURES

<u>Figure</u>	<u>Page</u>	
1	Gravel-cobble size armoring in Colorado River below Glen Canyon Dam in July 1975	7
2	Material underlying armor layer in Colorado River below Glen Canyon Dam in July 1975	8
3	Size of channel bottom sediment Colorado River, Lees Ferry to Glen Canyon Dam	8
4	Tractive force versus transportable sediment size (after Lane, 1952)	11
5	Shields diagram for initiation of bed material movement	13
6	Armoring definition sketch	14
7	Degraded channel profile - three-slope method general characteristics	23
8	Navajo Indian Irrigation Project - scour versus unit discharge	33
9	Chart for estimating F_{b0} (after Blench, 1969)	35
10	Sketch of natural channel scour by regime method	36
11	Sketch of scour from water surface profile computations and reduced "n" for scour	39
12	Suggested competent mean velocities for significant bed movement of cohesionless materials, in terms of grain size and depth of flow (after Neill, 1973)	41

INTRODUCTION

The purpose of this technical guide is to present several methods which can be applied in computing degradation of a stream channel occurring because of changes in flow regimen or reduced sediment load below a dam or diversion dam, and to provide procedures to use in estimating maximum scour depth of channels for design of a structure such as a bridge or siphon crossing.

In this guide, the following definitions have been adopted:

Degradation. - The long-term process by which streambeds and flood plains are lowered in elevation due to the removal of material from the boundary by flowing water.

Aggradation. - The long-term process by which streambeds and flood plains are raised in elevation due to the deposition of material eroded and transported from other areas.

Scour. - The enlargement of a flow section by the removal of boundary material through the action of fluid motion during a single discharge event. The results of the scouring action may or may not be evident after the passing of the flood event.

BACKGROUND ON DEGRADATION

Computations by computer application of some of the more sophisticated mathematical models applied to degradation below a dam are not described in these guidelines. The best known of these solutions is the Corps of Engineers (1977) HEC-6 computer program. A more comprehensive and sophisticated Reclamation (Bureau of Reclamation) computer model, which can deal with uneven scour and deposition across and along a river is being developed and should be available for use in 1985. The objective of most models is to simulate the behavior of an alluvial channel by combining a steady-state backwater computation for defining channel hydraulics with a sediment transport model. It is often difficult to verify the sediment transportation results from models with the total sediment transport of the river under investigation. The desk calculator approach to channel degradation below a dam, developed for Reclamation and described by Lane (1948), was a forerunner to the more sophisticated mathematical models. Although more of the comprehensive mathematical models are becoming available, they are still undergoing development and change. An example of a study to verify one of these mathematical models is described by Mengis (1981). The methods described in this technical guide should be applied before any attempt to use the more sophisticated mathematical models.

Before undertaking any degradation study below a dam, an evaluation is needed of the degree of detail required to complete the study, of the appropriate design data for the dam, and of the future environmental conditions below the dam. The type of study described in this technical guide is considered a minimum requirement before recommending a more sophisticated mathematical model. There is considerable support for these procedures which were applied in studies prepared in the 1950's to channels such as the Colorado River

below Glen Canyon Dam, Middle Loup River below Milburn Dam, and Niobrara River below Norden Dam. Observed degradation patterns since construction below Glen Canyon Dam and Milburn Dam have supported the results of the degradation studies. In the case of Niobrara River below Norden Dam, a mathematical model study made by Shen (1981) agreed closely with results of the studies made using the procedure described in this guideline.

Most existing rivers or streams are in a quasi-equilibrium state when considered on a long-term basis. While in this state, the stream sediment processes of degradation and aggradation are relatively at a standstill and, if occurring, are only of localized nature. The state of stream equilibrium as described by Lane (1955) may be expressed qualitatively by the following equation:

$$Q_s D_m = k Q_b S_b \quad (1)$$

where:

- Q_s = Bed material discharge
- D_m = Effective diameter of bed material mixture
- Q_b = Water discharge to determine bedload transport
- S_b = Slope of the streambed
- k = Constant of proportionality

It is recognized that in some situations other hydraulic parameters may be equally important as slope.

When any one of the four variables is altered, one or more of the other variables must adjust in order to return the stream to a state of equilibrium. An obvious case is when a dam and reservoir are constructed on a stream, eliminating or diminishing the sediment load downstream from the dam. The relatively clear water released to the stream below the dam is capable of eroding both channel bed and banks when released in sufficient quantity. If the exposed bed and banks are composed of sediment particles that can be moved or picked up by the flowing water, degradation will occur. The degradation process can occur vertically (streambed), laterally (streambanks), or both depending upon the stream discharge and the particle size and cohesive properties of the material forming the bed and banks. In the process of establishing a new state of equilibrium, the stream slope will decrease and the sediment particles remaining in the streambed after some time lapse will be the coarser fraction of the original bed material. Equation 1 provides a comparative evaluation which merely indicates an imbalance in channel equilibrium to be expected and that a change in regimen is imminent. To quantify this change requires application of sediment transport equations either in the form of a mathematical model or in less detail by the empirically tested equations and procedures described in this technical guideline. The effect of this change in regimen below a dam is to produce general degradation and lowering of tailwater elevations.

Other examples of change in state of equilibrium are the disturbance created by transbasin diversions, wastewater, or return flows from an irrigation project which increase the water supply of a stream system. The resulting increase in the streamflow component in equation 1 will increase the normal

stream velocity which directly influences the sediment transport capacity of the stream. This in turn leads to channel adjustments which if uncontrolled will in time establish a new state of equilibrium.

A closely related problem that is not necessarily associated with the equilibrium relationship defined by equation 1 is the natural scour occurring at the time of a peak-flood discharge. Sufficient channel scour as described by Lane and Borland (1954) may occur during higher floodflows to cause severe damage or threaten the stability of any structure located either along the bank of a river or across the channel. In anticipation of channel scour, a crossing structure such as a siphon or bridge should be designed to withstand any scour which might occur in conjunction with the design flood.

GENERAL DEGRADATION

Basic Factors Influencing Degradation

The two basic factors influencing the extent of degradation in a stream channel are: (1) hydraulic properties including river channel velocities, hydraulic gradient or slope, and depths of flow associated with peak discharges and throughout the range in discharges, and (2) particle size distribution of sediments in the channel bed and banks. A careful evaluation of these factors is essential to any degradation analysis. One additional factor is the combination of streambed and valley controls which may exist in the channel reach subject to degradation. The controls may be rock outcrops, cobbles and boulders in the channel, vegetation growing along the banks, or manmade structures which act to control water levels and retard degradation processes. A control in the channel may in some cases prevent any appreciable degradation from occurring above it. Conversely, a change or removal of an existing control may initiate the degradation process.

The water discharge for the stream channel is essential to the analysis. This requires information on the volume as well as the flow release pattern from an operation study for a reservoir or from any planned increases to the water supply to a stream system. In many stream systems, both the volume and distribution of the change in water supply can be illustrated by use of a flow-duration curve. The flow-duration curve is a cumulative frequency relationship, usually used to represent long-term conditions, that shows the percent of time that specific discharges were equalled or exceeded in a given period. The curves representing a future water supply can be compared directly with historic flow-duration curves for evaluating the significance of any changes. Flow-duration curves are used in computer application of the mathematical modeling for studying river channel degradation. The approach described in this technical guideline for computing degradation utilizes the dominant discharge method for representing water discharge.

The discharge value used in degradation analysis is referred to as the dominant discharge for the stream channel. Dominant discharge is defined as the discharge which, if allowed to flow constantly, would have the same overall channel shaping effect as the natural fluctuating discharges as illustrated by the flow-duration curve. The dominant discharge used in channel stabilization work usually is considered to be either the bank-full

discharge or that peak discharge having a recurrence interval of approximately 2 years on an uncontrolled stream. When streamflow is regulated by an upstream dam, the problem of determining the dominant discharge becomes more difficult if detailed data on future reservoir releases are not available. If releases from the reservoir fluctuate considerably due to incoming floods, the mean daily discharge derived from an operation study which is equalled or exceeded on the average of once every 2 years can be considered as the dominant discharge.

The type of sediments forming the bed and banks of the stream channel will influence the extent of degradation. The type of bed material also dictates the approach used in estimating the depth or amount of degradation. In situations where the streambed is composed of transportable material extending to a depth greater than that to which the channel can be expected to degrade, the approach most useful is that of computing a stable channel slope, the volume of expected degradation, and then determining a three-slope channel profile which fits these values. However, in situations where the bed material includes a sufficient quantity of large size or coarse material which cannot be transported by normal river discharges, the best approach is to compute the depth of degradation required to develop an armoring layer. The formation of the armoring layer usually can be anticipated to control vertical degradation when approximately 10 percent or more of the bed material is of armoring size or larger. This layer develops as the finer material is sorted out and transported downstream. Vertical degradation occurs at a progressively slower rate until the armoring layer is of sufficient depth to inhibit the process.

Bed Material Sampling

Bed material samples of the surface layer as well as the underlying sediment should be collected for analysis throughout the reach of the river under investigation. It is important that samples be representative of the material in the zone of anticipated scour, that is vertically, laterally, and longitudinally. Therefore, the number of samples depends on the homogeneity of material in the streambed. If the streambed is fairly uniform, fine-grained material of sand sizes in the range from 0.062 to 2.0 mm, a volumetric or bulk sampling procedure is followed. Bulk samples usually are dug out by shovel from exposed sandbars, or for underwater conditions by a bed material sampler such as the BM-54, BMH-60, or BMH-80 (Federal Interagency Sedimentation Project, 1963). Core samples taken in the stream channel as a part of geologic site investigation may be used if they are considered representative of channel bed material. An example of a sampling program for bulk sampling would be to collect about three samples in each cross section which if located about 0.5 mi (0.8 km) apart for a 5 mi (8-km) reach would provide about 33 samples for sieve analysis. Each sample would contain both surface and subsurface material and an arithmetic average of all 33 samples would provide a composite sieve analysis.

The sampling of riverbeds composed of gravel or cobble material >2.0 mm which may be uniformly mixed through the degradation zone or as a pavement over finer size sediments is more complicated. A good description of sampling procedures under variable types of sediment is given by Wolman (1954), Kellerhals (1967), Leopold (1970), and Kellerhals and Bray (1971).

For a gravel or cobble bed river, the sampling procedure is dependent on the purpose or objectives of the study. If the investigator is conducting a sediment transport study to quantify the bedload movement, then surface samples of the streambed are needed. A degradation or scour study requires samples of both the surface as well as the underlying sediments. In the latter case, it is necessary for the investigator to determine either by sampling or judgment the appropriate procedure for properly weighting the proportion of surface and subsurface sediments.

The procedures for sampling and analysis of samples for gravel and cobble riverbeds can be quite varied depending on river conditions. For "deep water" sampling, a drag bucket technique is used. The size of the bucket is dependent on the size of rocks. A bucket-type "jaw" sampler with jagged edge on the open end of the bucket having a diameter of about 1 foot (0.3 m) has been used with some success by Reclamation for cobble bed material. On many rivers, deep water sampling can be avoided by finding an exposed gravel bar with materials observed to be similar to the underwater material and sampling under dry bed conditions.

The techniques for sampling of bed material on exposed gravel bars or under shallow water are described by Wolman (1954) or Kellerhals and Bray (1971). The most common methods are:

1. Volume or bulk sample collected for sieve analysis by weight.
2. Grid sampling where all material in a specified surface area is collected, usually a square that can vary from 1.5 to 3 ft (0.5 to 0.9 m) on each side.
3. Random sampling of rocks at predetermined distance along a straight line usually by a random step procedure or collecting those at grid intersection points over a large areal coverage such as a 50-ft (15-m) square.

All three methods require an investigator to make a field selection for site selection based on representativeness of the bed material. Method 1 usually is applicable to small size gravels where the sample can be taken to a laboratory for sieve analysis. Methods 2 and 3 are applicable to larger rock where a surface count and measurement of the larger particles can be made and then converted to an equivalent customary bulk sieve analysis. The conversion is especially important if finer material is encountered during the count method which could be analyzed by sieve analysis and combined with the count method for a composite size analysis.

The count method involves the measurement of the intermediate axis of particles larger than about 1/2 inch (13 mm). Each rock is measured and grouped into an appropriate size and class and then thrown away. A minimum of from 75 to 100 rocks usually are considered necessary to have a representative sample. The conversion or weighting factor for each size fraction is directly proportional to D^3 with D being the geometric mean diameter for a size fraction. An example computation for conversion of rock count to sieve analysis by weight is shown in table 1 for sample No. B-2 in the Colorado River. It is advisable to photograph the bed material at all sampling

locations. If the surface material is sampled by the count method, a photograph of this material as well as the underlying material is important. Figures 1 and 2 show the surface material and underlying sediments at a sampling location on the Colorado River (Pemberton, 1976). Figure 3 illustrates the results of sampling programs conducted in the Colorado River below Glen Canyon Dam prior to construction of the dam in 1956 and subsequent to construction in 1966 and 1975. The armor material in 1966 and 1975 was analyzed by the count method while all other samples were averaged from a bulk sieve analyses.

Table 1. - Conversion of rock count (grid-by-number) to sieve analysis by weight - Sample No. B-2 Colorado River below Glen Canyon Dam - 1975

Size D <u>1/</u>		Weighting factor D^3 (mm^3) (10^3)	Count in size range	Count x D^3 (10^6)	Per-centage	Percent finer	
Size range in	Geometric mean mm in						
9 to 8	216	8.49	10 100	3	30.3	15.9	100
8 to 6	176	6.93	5 450	14	76.3	40.2	84.1
6 to 4	124	4.90	1 910	28	53.5	28.2	43.9
4 to 2	72	2.83	373	72	26.9	14.1	15.7
2 to 0.75	31	1.22	298	100	2.98	1.6	1.6
				217	189.98	100	

1/ Measurement of intermediate axis.

Hydraulic Properties

The hydraulic properties of the stream channel at the dominant discharge are required in the degradation analysis. These properties include flow area, width, depth, and velocity which usually can be obtained from the water surface profile computations for the tailwater reach downstream from the dam. The accuracy of the field data in defining channel hydraulics as well as location of the proper channel sections is comparable to that given in the criteria for a water surface profile computation described by Reclamation (1957). The hydraulic properties of all the cross sections are averaged for the dominant discharge to determine representative data in the reach where degradation is expected to occur. If a distinct break in slope occurs in the overall reach, a subdivision into one or more reaches selected on the basis of slope should be made for averaging the hydraulic properties. The water surface slope is assumed equal to the energy gradient for all computations.

Upon obtaining data on particle size of bed and bank material and the channel hydraulic properties, a method of analysis is chosen to apply to the stream channel being considered. The two techniques presented in the following discussion, either the armoring or limiting slope method, are recommended as

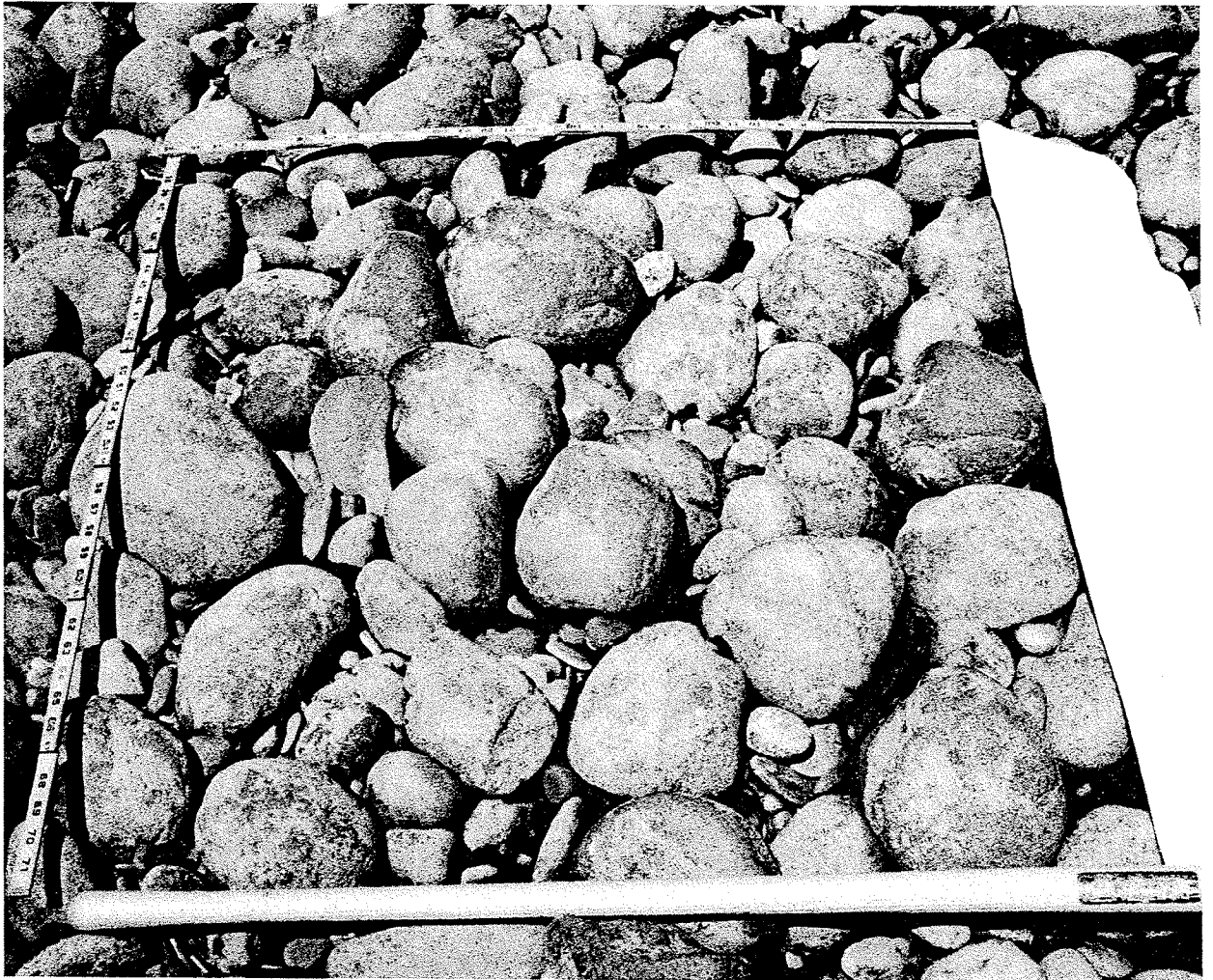

Figure 1. - Gravel-cobble size armoring in Colorado River below Glen Canyon Dam in July 1975.

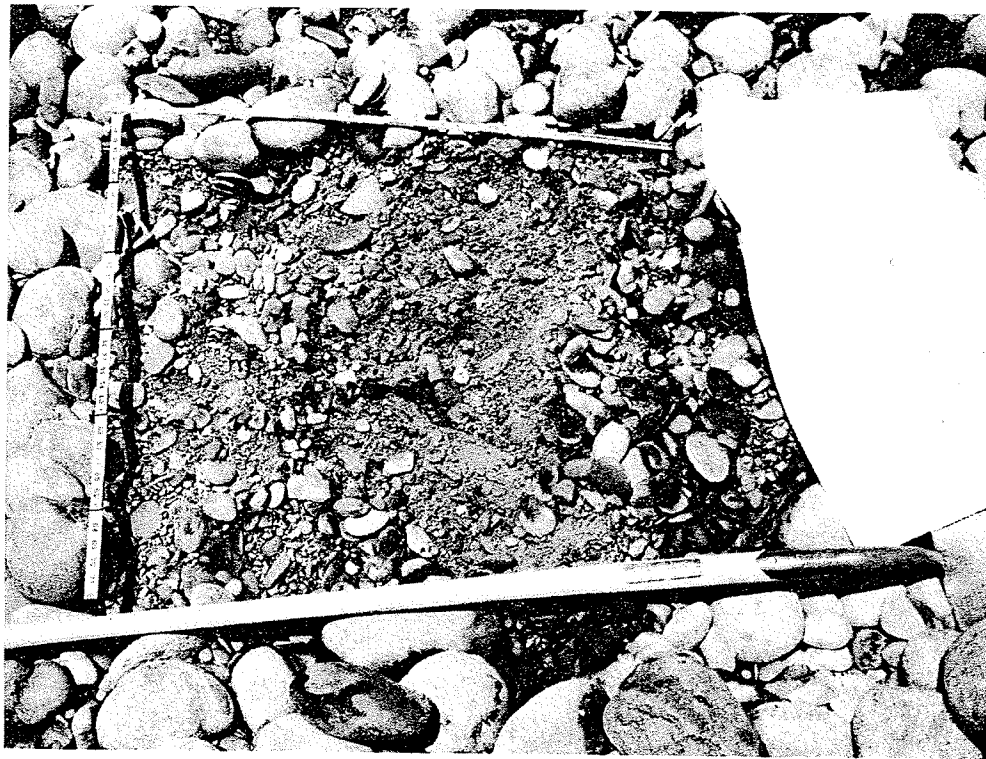

Figure 2. - Material underlying armor layer in Colorado River below Glen Canyon Dam in July 1975.

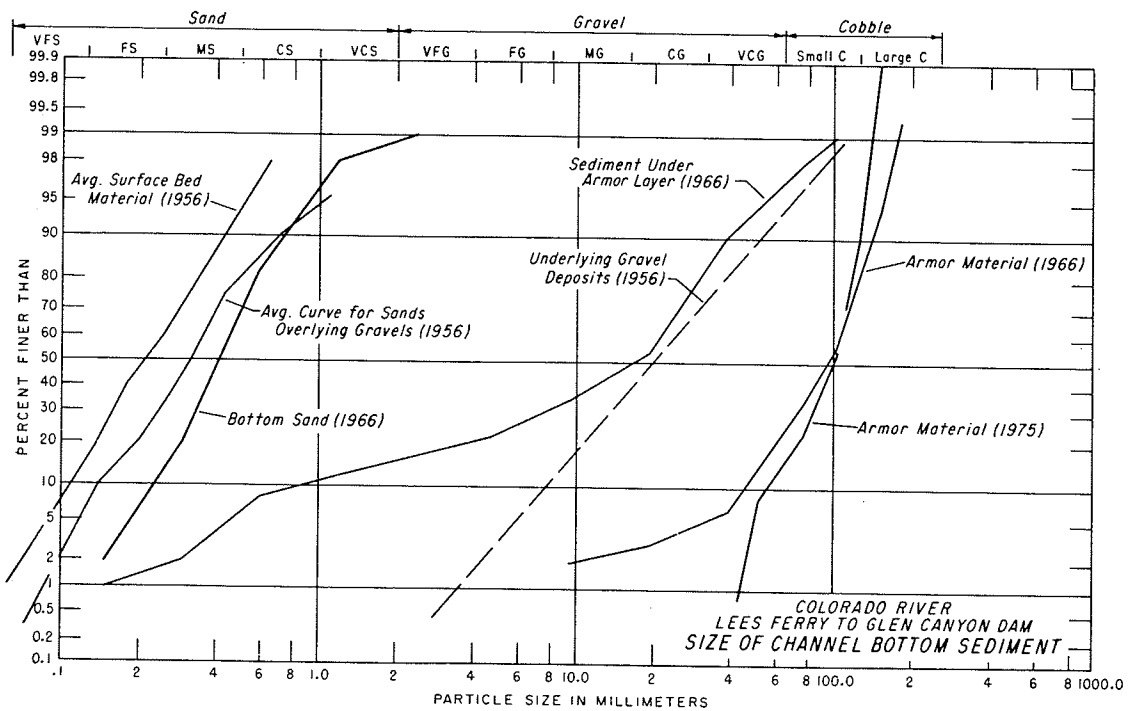

Figure 3. - Size of channel bottom sediment Colorado River, Lees Ferry to Glen Canyon Dam.

alternative choices. For general degradation, the armoring method is tested first because a sediment transport study may not be necessary with a resulting savings in time and cost for computations. If the armoring method is not applicable, then the stable slope method is used.

DEGRADATION LIMITED BY ARMORING

When the channel bed downstream from a dam contains more than 10 percent coarse material which cannot be transported under dominant flow conditions armoring will in time develop. The formation of an armoring layer at the maximum depth of degradation will depend on such factors as reservoir operations, the amount of armoring material available in the scour depth zone below streambed, and the distance to which this material extends downstream.

There are several ways to compute the size of bed material required for armoring and each method is regarded as a check on the others. Each method computes a different armoring size and some judgment may be required in selecting the lower size limitation of nontransportable material. Reclamation recommends the following methods to determine armoring size:

1. Meyer-Peter, Muller (bedload transport equation)
2. Competent bottom velocity
3. Lane's tractive force theory
4. Shields diagram
5. Yang incipient motion

Meyer-Peter, Muller (Bedload Transport Equation)

Bedload transport equations provide a method to compute a nontransportable particle size representing coarse bed material capable of forming an armoring layer. To describe a nontransportable size, the Meyer-Peter, Muller (1948) bedload equation (Sheppard, 1960) for beginning transport of individual particle sizes, may be applied when rewritten in the form:

$$D_c = \frac{dS}{K \left(\frac{n_s}{D_{90}} \right)^{1/6}}^{3/2} \quad (2)$$

where:

- D_c = Individual particle size in millimeters
- K = 0.19 inch-pound units (0.058 metric units)
- d = Mean water depth at dominant discharge, ft (m)
- S = Slope of energy gradient, ft/ft (m/m)
- n_s = Manning's "n" for bed of stream
- D_{90} = Particle size in millimeter at which 90 percent of bed material by weight is finer

Bedload equations, such as the Schoklitsch equation (Shulits, 1935), that were developed on an experimental basis for material of a uniform size, may also be applied using the individual particle size rather than the mean size. Other bedload equations could also be used to determine the transport rate of various particle size ranges for the dominant discharge condition, selecting that size range where the transport becomes negligible as the representative armoring size. Some judgment is required in choosing the point where the transport is adequately diminished such as to reasonably assume that the particular size range is coarse enough to actually form an armor.

Competent Bottom Velocity

Investigations show that the size of a particle plucked from a streambed is proportional to the velocity of flow near the bed. The particle starts to move at what is called the competent bottom velocity (Mavis and Laushey, 1948) which is approximately 0.7 times V_m , the mean channel velocity. The competent bottom velocity method for determining armoring size is computed from a relationship between mean channel velocity with armoring size by the equation:

$$D_C = 1.88 V_m^2 \text{ inch-pound units} \quad (3)$$

$$D_C = 20.2 V_m^2 \text{ metric units}$$

where:

$$D_C = \text{Armor size, mm}$$

$$V_m = \text{Mean channel velocity, ft/s (m/s)}$$

Lane's Tractive Force

The tractive force method is based on the results of a study by Lane (1952). He summarized the results of many studies in a relationship of critical tractive force versus the mean particle size diameter in millimeters, which is reproduced on figure 4. This method entails computing the critical tractive force (equation 4) using the channel hydraulics for dominant discharge. By selecting an appropriate curve on figure 4, usually the recommended set of "curves for canals with clear water in coarse noncohesive material," a critical tractive force gives the lower size limit of the nontransportable material, D_C .

$$T_C = \gamma_w d S \quad (4)$$

where:

$$T_C = \text{Critical tractive force, lb/ft}^2 \text{ (g/m}^2\text{)}$$

$$\gamma_w = \text{Specific weight (mass) of water, 62.4 lb/ft}^3 \text{ (1 t/m}^3\text{)}$$

$$d = \text{Mean water depth, ft (m)}$$

$$S = \text{Slope, ft/ft (m/m)}$$

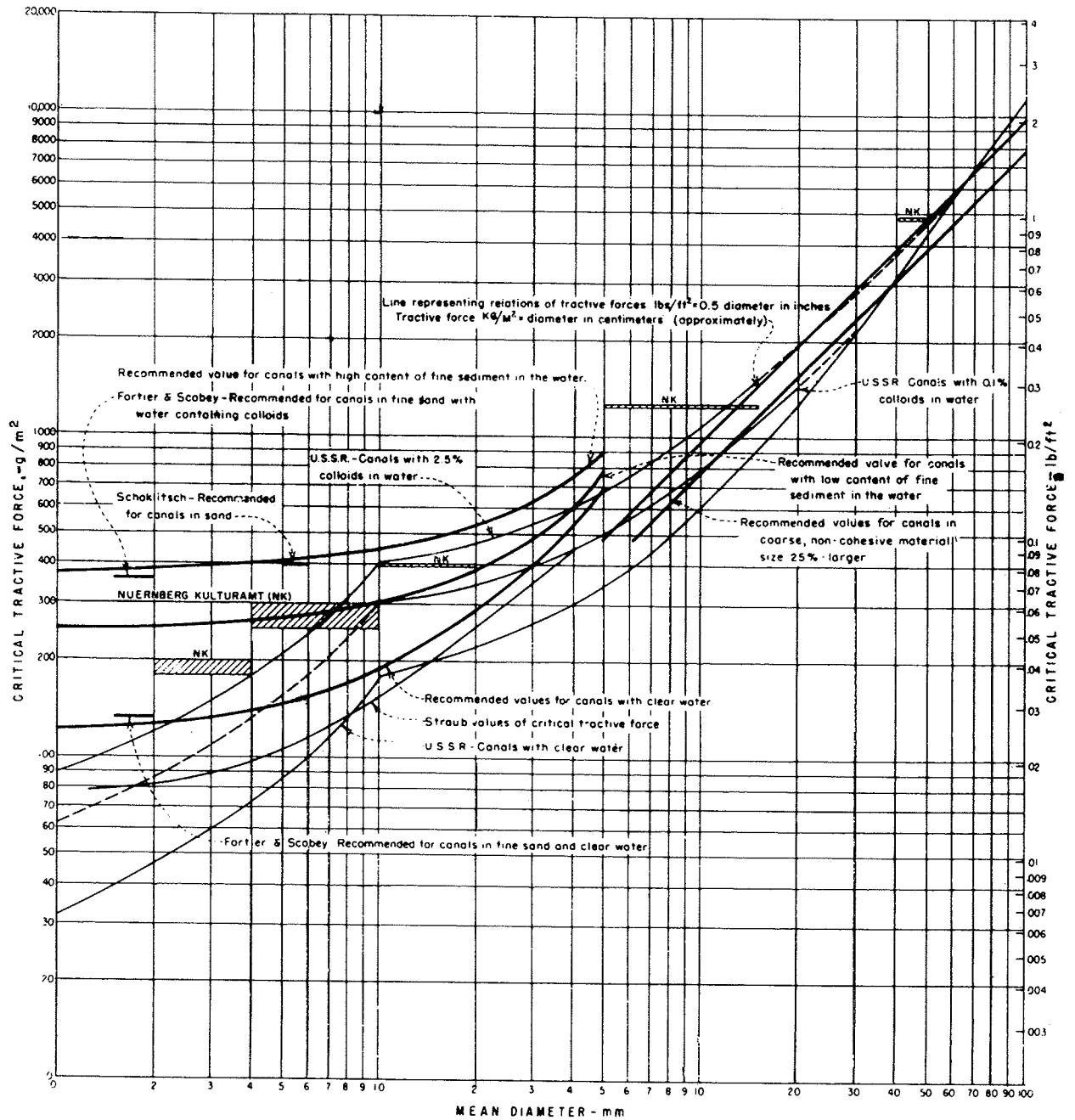

Figure 4. - Tractive force versus transportable sediment size (after Lane, 1952).

Shields Diagram

Many investigators use the Shields diagram (Shields, 1936), figure 5, to define the initiation of motion for various particle sizes. In the process of armoring of a streambed for predominately gravel size material >1.0 mm and high Reynold's number $R_* > 500$, the Shields parameter given below provides a method for determining an armor size.

$$T_* = \frac{T_C}{(\gamma_S - \gamma_W)D_C} = 0.06 \quad (5)$$

where:

T_* = Dimensionless shear stress
 T_C = Critical shear stress = $\gamma_W d S$, lb/ft² (t/m²)
 γ_S = Specific weight (mass) of the particle
 γ_W = Specific weight (mass) of water
 D_C = Diameter of particle

<u>Inch-pound units</u>	<u>Metric units</u>
$\gamma_W = 62.4 \text{ lb/ft}^3$	$\gamma_W = 1.0 \text{ t/m}^3$
$\gamma_S = 165 \text{ lb/ft}^3$	$\gamma_S = 2.65 \text{ t/m}^3$
d = depth, ft	d = depth, m
S = slope, ft/ft	S = slope, m/m
D_C = size, ft	D_C = size, m

Yang Incipient Motion

Yang (1973) developed a relationship between dimensionless critical velocity, V_{Cr}/w , and shear velocity Reynold's number, R_* , at incipient motion. Under rough regime conditions where $R_* > 70$, the equation for incipient motion which is considered applicable to bed material size larger than about 2 mm by Reclamation is:

$$\frac{V_{Cr}}{w} = 2.05 \quad (6)$$

where:

V_{Cr} = Critical average water velocity at incipient motion, ft/s (m/s)
w = Terminal fall velocity, ft/s (m/s)

The settling velocity by Rubey (1933) for material larger than 2 mm in diameter will approximate the fall velocity by:

$$w = 6.01 D_C^{1/2} \text{ inch-pound units} \quad (7)$$

$$w = 3.32 D_C^{1/2} \text{ metric units}$$

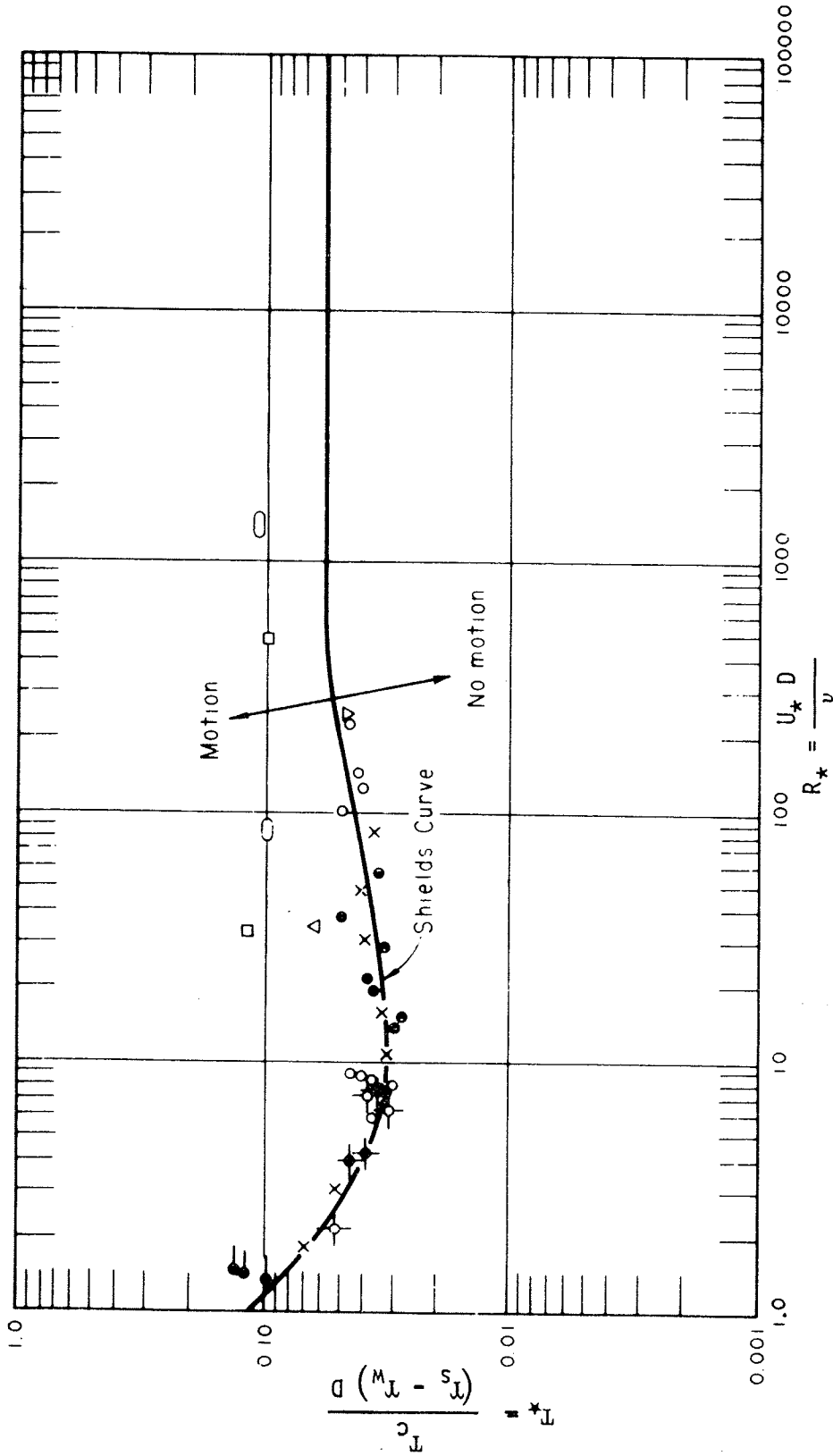

Sym	Description	$\gamma_s, \text{g/cm}^3$
○	Amber	1.06
●	Lignite (Shields)	1.27
●	Granite	2.7
●	Barite	4.25
x	Sand (Casey)	2.65
◆	Sand (Kramer)	2.65
◆	Sand (U.S.W.E.S.)	2.65
▽	Sand (Gilbert)	2.65

Fully developed
turbulent
velocity profile

○	Sand (Vanoni)	2.65
●	Glass beads (Vanoni)	2.49
□	Sand (White)	2.61
○	Sand in air (White)	2.10
△	Steel shot (White)	7.9

Turbulent
boundary
layer

Figure 5. - Shields diagram for initiation of bed material movement

Equations 6 and 7 can be combined to give:

$$D_c = 0.00659 V_{cr}^2 \text{ inch-pound units} \quad (8)$$

$$D_c = 0.0216 V_{cr}^2 \text{ metric units}$$

Depth to Armor and Volume Computations

After determining the size of the material required to armor the streambed, from either an average of the five methods or a judgment decision on the best method, an estimate can be made of the probable vertical degradation before stabilization is reached. The armoring computations assume that an armoring layer will form as shown on figure 6 by the equations:

$$\text{and} \quad y_a = y - y_d \quad (9)$$

$$y_a = (\Delta p) y \quad (10)$$

which are combined to:

$$y_d = y_a \left(\frac{1}{\Delta p} - 1 \right) \quad (11)$$

where:

y_a = Thickness of armoring layer

y = Depth from original streambed to bottom of the armoring layer

y_d = Depth from original streambed to top of armoring layer or the depth of degradation

Δp = Decimal percentage of original bed material larger than the armor size, D_c

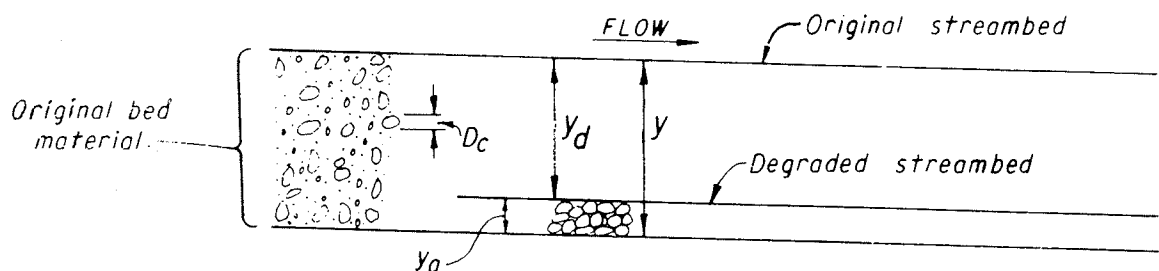

y = Depth to bottom of the armoring layer

y_d = Depth of degradation

y_a = Armoring layer

D_c = Diameter of armor material

Δp = Decimal percentage of original bed material larger than D_c

Figure 6. - Armoring definition sketch.

The percentage of the bed material equal to or greater than the required armoring size, D_c , can be determined from the bed material size analysis curve from samples collected of the streambed material through the reach involved and at a depth through the anticipated scour zone. This size analysis gives the value Δp to be used in equation 11. The depth, y_a , of the required armoring may vary, depending on the limiting particle size, from a thickness of one particle diameter to three particle diameters or one and three times the armoring size, respectively. A rough guide for use in design is either three armoring particle diameters or 0.5 ft (0.15 m), whichever is smaller. Although armoring has been observed to occur with less than three particle diameters, variability of channel bed material and occurrence of peak discharges dictate the use of a thicker armor layer.

The armoring technique is based on two basic assumptions that may or may not hold for the particular channel studied. The assumptions are: (a) that the degraded channel will have the same hydraulic conditions as the existing channel, and (b) that the ultimate slope of the degraded channel would be equal to the slope of the existing channel. Lateral degradation or erosion of the channel banks may occur simultaneously with armoring of the streambed. A description of the methods for predicting lateral degradation is given in subsequent section "Degradation Limited by a Stable Slope."

An example of the streambed degradation computation limited by armoring using the five recommended methods are given below. The following data are known for the example computations for a channel downstream of a storage dam:

Q = Dominant discharge = 500 ft³/s (14.2 m³/s)
 B = Channel width = 60 feet (18.3 meters)
 d = Mean channel depth = 4 feet (1.22 meters)
 V_m = Mean channel velocity = 3.4 ft/s (1.04 m/s)
 S = Stream gradient = 0.0021
 D_c = Armoring size = diameter in millimeters
 n_s = Manning's "n" for bed of stream = 0.03

Meyer-Peter, Muller (bedload transport equation):

Inch-pound units

$$D_c = \frac{dS}{0.19 \left(\frac{n_s}{D_{90}} \right)^{3/2}}$$

D_{90} assumed = 34 mm

$$D_c = \frac{4.0 (0.0021)}{0.19 \left(\frac{0.03}{34} \right)^{3/2}}$$

$$D_c = \frac{0.0048}{0.000409} = 20 \text{ mm}$$

Metric units

$$D_c = \frac{dS}{0.058 \left(\frac{n_s}{D_{90}} \right)^{3/2}}$$

D_{90} = 34 mm

$$D_c = \frac{1.22 (0.0021)}{0.058 \left(\frac{0.03}{34} \right)^{3/2}}$$

$$D_c = \frac{0.00256}{0.000125} = 20 \text{ mm}$$

Competent bottom velocity:

Inch-pound units

$$D_c = 1.88 V_m^2$$

$$D_c = 1.88 (3.4)^2$$

$$D_c = 22 \text{ mm}$$

Metric units

$$D_c = 20.2 V_m^2$$

$$D_c = 20.2 (1.04)^2$$

$$D_c = 22 \text{ mm}$$

Lane's tractive force:

Inch-pound units

$$T_c = \gamma_w dS$$

$$T_c = 62.4 (4.0)(0.0021)$$

$$T_c = 0.524 \text{ lb/ft}^2$$

$$D_c \text{ from figure 4} = 31 \text{ mm}$$

Metric units

$$T_c = \gamma_w ds$$

$$T_c = 10^6 \text{ g/m}^3 (1.22) (0.0021)$$

$$T_c = 2560 \text{ g/m}^3$$

$$D_c \text{ from figure 4} = 31 \text{ mm}$$

Shields diagram:

Inch-pound units

$$D_c = \frac{\gamma_w dS}{0.06 (\gamma_s - \gamma_w)}$$

$$D_c = \frac{62.4 (4.0) (0.0021)}{0.06 (165 - 62.4)}$$

$$D_c = 0.0851 \text{ ft}$$

$$D_c = 26 \text{ mm}$$

Metric units

$$D_c = \frac{\gamma_w dS}{0.06 (\gamma_s - \gamma_w)}$$

$$D_c = \frac{1.0 (1.22) (0.0021)}{0.06 (2.65 - 1)}$$

$$D_c = 0.026 \text{ m}$$

$$D_c = 26 \text{ mm}$$

Yang incipient motion:

Inch-pound units

$$D_c = 0.00659 V_{cr}^2$$

$$D_c = 0.00659 (3.4)^2$$

$$D_c = 0.00762 \text{ ft}$$

$$D_c = 23 \text{ mm}$$

Metric units

$$D_c = 0.0216 V_{cr}^2$$

$$D_c = 0.0216 (1.04)^2$$

$$D_c = 0.0234 \text{ m}$$

$$D_c = 23 \text{ mm}$$

Mean of the above five methods for computing armoring size is 24 mm, which was adopted as a representative armoring size. By use of equations 10 and 11, a three-layer thickness of nontransportable material to form an armor, and an assumed 17 percent of bed material >24 mm (from size analysis of streambed material), the depth of degradation is:

$$y_a = 3D_c = 3 (24) = 72 \text{ mm} = 0.236 \text{ ft} (0.072 \text{ m})$$

Inch-pound units

$$y_d = y_a \left(\frac{1}{\Delta p} - 1 \right)$$

$$y_d = 0.236 \left(\frac{1}{0.17} - 1 \right)$$

Metric units

$$y_d = y_a \left(\frac{1}{\Delta p} - 1 \right)$$

$$y_d = 0.072 \left(\frac{1}{0.17} - 1 \right)$$

$$y_d = 1.15 \text{ ft}$$

$$y_d = 0.351 \text{ m}$$

It is difficult to determine the distance that degradation will extend downstream when an armoring condition is the limiting factor. With the assumption that the degraded and existing slopes are the same, degradation can be predicted to extend downstream until the volume of material degraded from the channel plus tributary contributions equals the estimated annual volume of eroded material multiplied by some time period usually equal to the economic life of the structure in the following equation form:

$$V_g = V_A T \quad (12)$$

where:

V_g = Total volume of degradation, ft^3 (m^3)

V_A = Estimated annual volume of eroded material, ft^3/yr (m^3/a)

T = Time in years (equals 100 years for most USBR studies)

The actual physical process of degradation begins at the dam and continues downstream with the depth of degradation diminishing in proportion to the sediment load picked up below the dam. As the upstream reach becomes armored, degradation, and, consequently, channel pickup is reduced and the next reach downstream is subjected to a similar degradation process until it armors, after which the process moves on down river.

In the more sophisticated mathematical models degradation computations are made by dividing the stream into reaches. An initial step is to compute the volume of sediment carried out of each reach by the riverflows over a specified time frame. The difference between the volume of material transported out of the reach and that brought into the reach from the immediate upstream reach would determine the degradation in the reach.

DEGRADATION LIMITED BY A STABLE SLOPE

The limiting or stable slope method for computing degradation is based on the degrading process controlled by zero or negligible transport of the material forming the bed of the stream channel. It can be applied to cases where the amount of coarse material is insufficient to form an armoring layer on the channel bed.

The stable slope is determined by application of several methods such as (1) Schoklitsch bedload equation (Shulits, 1935) for conditions of zero bedload transport, (2) Meyer-Peter, Muller (1948) bedload equation for beginning transport, (3) Shields (1936) diagram for no motion, and (4) Lane's (1952) relationship for critical tractive force assuming clear water-flow in canals. Other bedload equations are equally as applicable as the Schoklitsch or Meyer-Peter, Muller equations for zero bedload transport. However, many of these involve trial and error computations until a slope is found to produce negligible bedload transport.

Stable slope computations are made for the dominant discharge which is defined as the flow effecting the ultimate shape and hydraulics of the channel.

Schoklitsch Method

The Schoklitsch equation for zero bedload transport is expressed as follows:

$$S_L = K \left(\frac{DB}{Q} \right)^{3/4} \quad (13)$$

where:

- S_L = Stable slope, ft/ft (m/m)
- K = 0.00174 inch-pound units (0.000293 metric units)
- D = Mean particle size, mm
- B = Channel width, ft (m)
- Q = Dominant discharge, ft³/s (m³/s)

Meyer-Peter, Muller Method

Limiting slope computations by the Meyer-Peter, Muller beginning transport equation are:

$$S_L = \frac{K \left(\frac{Q}{Q_B} \right) \left(\frac{n_s}{D_{90}^{1/6}} \right)^{3/2} D}{d} \quad (14)$$

where:

- S_L = Stable slope, ft/ft (m/m)
- K = 0.19 inch-pound units (0.058 metric units)
- $\frac{Q}{Q_B}$ = Ratio of total flow in ft³/s (m³/s) to flow over bed of stream in ft³/s (m³/s). Usually defined at dominant discharge where $\frac{Q}{Q_B} = 1$ for wide channels
- D_{90} = Particle size at which 90 percent of bed material by weight is finer
- n_s = Manning's "n" for bed of stream
- D = Mean particle size, mm
- d = Mean depth, ft (m)

Shields Diagram Method

The use of Shields diagram for computing a stable slope involves the relationship of the boundary Reynold's number R_* varying with the dimensionless shear stress T_* shown on figure 5 as follows:

$$R_* = \frac{U_* D}{\nu} \quad (15)$$

where:

- R_* = boundary Reynold's number
- U_* = Shear velocity $\sqrt{S_L R g}$, ft/s (m/s)
- S_L = Slope, ft/ft (m/m)
- R = Hydraulic radius or mean depth for wide channels, ft (m)
- g = Acceleration due to gravity, 32.2 ft/s² (9.81 m/s²)
- D = Particle diameter, ft (m)
- ν = Kinematic viscosity of water varying with temperature, ft²/s (m²/s)

and

$$T_* = \frac{T_C}{(\gamma_s - \gamma_w) D} \quad (16)$$

where:

- T_* = Dimensionless shear stress
- T_C = Critical shear stress lb/ft² (t/m²) equal to $\gamma_w d S_L$
- γ_s = Specific weight (mass) of particles, 165.4 lb/ft³ (2.65 t/m³)
- γ_w = Specific weight (mass), 62.4 lb/ft³ (1 t/m³)
- d = Mean depth, ft (m)
- S_L = Slope, ft/ft (m/m)
- D = Particle diameter, ft (m)

Lane's Tractive Force Method

The fourth method suggested for computing the stable slope is to use the critical tractive force relationships shown by Lane (1952). Critical tractive force is defined as the drag or shear acting on the wetted area of the channel bed and is expressed as:

$$T_C = \gamma_w d S_L \quad (17)$$

rewriting in terms of S_L

$$S_L = T_C / \gamma_w d \quad (18)$$

where:

- T_C = Critical tractive force, lb/ft² (t/m²) (may be read from the curve on figure 4. Enter the abscissa scale with the D_{50} or D_m in millimeters and read the critical tractive force value from the curves for canals with clear water)
- γ_w = Specific weight (mass) of water, lb/ft³ (t/m³)
- d = Mean water depth for dominant discharge, ft (m)

Example of the Stable Slope Computations

An example problem for a stable or limiting slope, S_L , computation is given below showing the four methods:

- Q = Dominant discharge = 780 ft³/s (22.1 m³/s)
- B = Channel width = 350 ft (107 m)
- d = Mean water depth = 1.05 ft (0.32 m)
- S = Slope of energy gradient = 0.0014

D = Bed material size $D_{50} = 0.000984$ ft (0.3 mm)
 $D_{90} = 0.00315$ ft (0.96 mm)
 n_s = Manning's "n" for bed of stream = 0.027
 V = Mean velocity from Manning's equation = 2.13 ft/s (0.649 m/s)
 ν = Kinematic viscosity of water = 1×10^{-5} ft²/s (0.929×10^{-6}) m²/s

SCHOKLITSCH METHOD:

$$S_L = K \left(\frac{DB}{Q} \right)^{3/4}$$

Inch-pound units

$$S_L = 0.00174 \left(\frac{0.3 \times 350}{780} \right)^{3/4}$$

$$S_L = 0.00174 (0.222)$$

$$S_L = 0.000386 \text{ ft/ft}$$

Metric units

$$S_L = 0.000293 \left(\frac{0.3 \times 107}{22.1} \right)^{3/4}$$

$$S_L = 0.000293 (1.32)$$

$$S_L = 0.000386 \text{ m/m}$$

MEYER-PETER, MULLER METHOD:

Inch-pound units

$$S_L = \frac{K \left(\frac{Q}{QB} \right) \left(\frac{n_s}{D_{90}^{1/6}} \right)^{3/2} D}{d}$$

$$S_L = \frac{0.19 (0.3) \left(\frac{0.027}{(0.96)^{1/6}} \right)^{3/2}}{1.05}$$

$$S_L = \frac{0.057 (0.00448)}{1.05}$$

$$S_L = 0.000243 \text{ ft/ft}$$

Metric units

$$S_L = \frac{0.058 (0.3) \left(\frac{0.027}{(0.96)^{1/6}} \right)^{3/2}}{0.32}$$

$$S_L = \frac{0.0174 (0.00448)}{0.32}$$

$$S_L = 0.000243 \text{ m/m}$$

SHIELDS DIAGRAM METHOD:

Inch-pound units

$$R_* = \frac{U_* D}{\nu}$$

vs.

Metric units

$$T_* = \frac{T_C}{(\tau_s - \tau_w) D} \text{ on figure 5}$$

$$U_* = \sqrt{S R g}$$

$$R_* = \frac{(0.0014 \times 1.05 \times 32.2)^{1/2} (0.000984)}{1 \times 10^{-5}}$$

$$R_* = \frac{0.218 (0.000984)}{0.00001} = 21.5$$

$$R_* = \frac{(0.0014 \times 0.32 \times 9.81)^{1/2} (0.0003)}{0.929 \times 10^{-6}}$$

$$R_* = \frac{0.0663 (0.0003)}{0.929 \times 10^{-6}} = 21.4$$

Inch-pound units

from figure 5, $T_{*} = 0.035 = \frac{T_c}{(\gamma_s - \gamma_w)D}$

$$S_L = \frac{0.035 (165.4 - 62.4) (0.000984)}{62.4 (1.05)}$$

$$S_L = 0.0000541$$

recompute $R_{*} = 21.5 \left(\frac{0.0000541}{0.0014} \right)^{1/2}$

$$R_{*} = 4.23$$

from figure 5, $T_{*} = 0.039 = \left(\frac{T_c}{\gamma_s - \gamma_w} \right) D$

$$S_L = \frac{0.039 (103) (0.000984)}{62.4 (1.05)}$$

$$S_L = 0.0000603 \text{ ft/ft}$$

Metric units

from diagram, $T_{*} = 0.035$

$$S_L = \frac{0.035 (2.65 - 1) (0.0003)}{1 (0.32)}$$

$$S_L = 0.0000541$$

recompute $R_{*} = 21.4 \left(\frac{0.0000541}{0.0014} \right)^{1/2}$

$$R_{*} = 4.23$$

from diagram, $T_{*} = 0.039 \left(\frac{T_c}{\gamma_s - \gamma_w} \right) D$

$$S_L = \frac{0.039 (1.65) (0.0003)}{1 (0.32)}$$

$$S_L = 0.0000603 \text{ m/m}$$

LANE'S TRACTIVE FORCE METHOD:

$$T_c = \gamma_w dS_L \text{ or } S_L = T_c / \gamma_w d$$

Read figure 4 with $D = 0.3 \text{ mm}$

Inch-pound units

$$T_c = 0.028 \text{ lb/ft}^2$$

$$S_L = \frac{0.028}{62.4 (1.05)}$$

$$S_L = 0.000427 \text{ ft/ft}$$

Metric units

$$T_c = 137 \text{ g/m}^2$$

$$S_L = \frac{137}{1 \times 10^6 (0.32)}$$

$$S_L = 0.000427 \text{ m/m}$$

The selection of the most appropriate stable or limiting slope can be based on an average of all four methods as shown below in table 2 or can be selected from the technique considered most applicable. In applying any of the methods, some judgmental changes could be made in assumptions of no change in channel hydraulics or bed material particle size analysis. In the example problem, a possible change would be to assume that with degradation the D_{50} could increase to greater than the 0.3 mm. However, this change would be dependent on the characteristics of the particle size distribution curve. In some situations, the stable slope computed by any of the four methods could be equal to or greater than the streambed slope. This would indicate a negligible amount of degradation usually applicable to a streambed that is already armored or the equation is not applicable to this case. Depending on field conditions for an appraisal level investigation, the stable slope could be taken as equal to one-half the streambed slope and used in the computations.

Table 2. - Stable slope

Method	Stable slope ft/ft (m/m)
1. Schoklitsch	0.000386
2. Meyer-Peter, Muller	0.000243
3. Shields diagram	0.0000603
4. Lane's tractive force	<u>0.000427</u>
Average	0.000279

Volume computations

The next step in the degradation computations is to estimate the volume of material expected to be removed from the channel. If there are no downstream controls or bedrock outcrops that would limit the degradation process and little depletion in the steamflow with minor regulation by the reservoir upstream, it can be assumed the stream is capable of picking up a load of coarse sediments (particle sizes greater than 0.0625 mm) equal to that portion of the historic load greater than 0.0625 mm. If, however, the streamflow is depleted or significantly regulated, the sediment load picked up from the channel will be less than the historic load, which is greater than 0.0625 mm. This new sediment load can be determined from a sediment rating curve or plot of stream discharge versus sediment transport specifically for sizes equal to or greater than 0.0625 mm. The rating curve is developed from Modified Einstein computations described by Colby and Hembree (1955), Bureau of Reclamation (1955), and Bureau of Reclamation (1966) from measured data taken at a section considered representative of the downstream channel degradation reach. If sufficient observed data are not available, a curve can be developed from computed transport values determined by application of appropriate bed material load equations (ASCE, 1975; Simons and Senturk, 1977; and Strand and Pemberton, 1982) that utilize the channel geometry defined by the channel cross sections of the reach being investigated. The annual load determined from this curve by weight (mass) can be converted, through the river density analysis described by Lara and Pemberton (1965), to an annual volume of degradation, V_A .

The annual volume multiplied by a time period T (usually equal to 100 years or the economic life of the structure) gives the total volume of degradation, V_g , in ft^3 (m^3) usually expressed by equation 12.

After determining the stable slope and volume of material removed, the mean depth of degradation applicable to the entire width of the channel at the dam can be computed and the degraded channel profile defined as shown on figure 7. The practical accuracy of the results of this technique improves when the following conditions prevail:

1. The future degraded channel will not differ greatly from the existing channel; thus, the stream channel geometry defined by average cross sections is common to both existing and degraded conditions.

2. The slope of the existing streambed within the expected degraded channel reach is fairly uniform; therefore, an average gradient can be used for the computations.
3. The bed material is considered homogeneous throughout the reach and can be represented by a single particle size gradation curve.
4. The bed is free of any nonerrodible barriers that would prevent the stream from degrading to form the average stable section at the stable slope.

The depth of degradation and degraded profiles are determined by the following procedure using the stable slope technique:

First the longitudinal area defined as that area between the existing streambed and degraded streambed (see fig. 7) is computed by the equation:

$$a_g = V_g/B_d \quad (19)$$

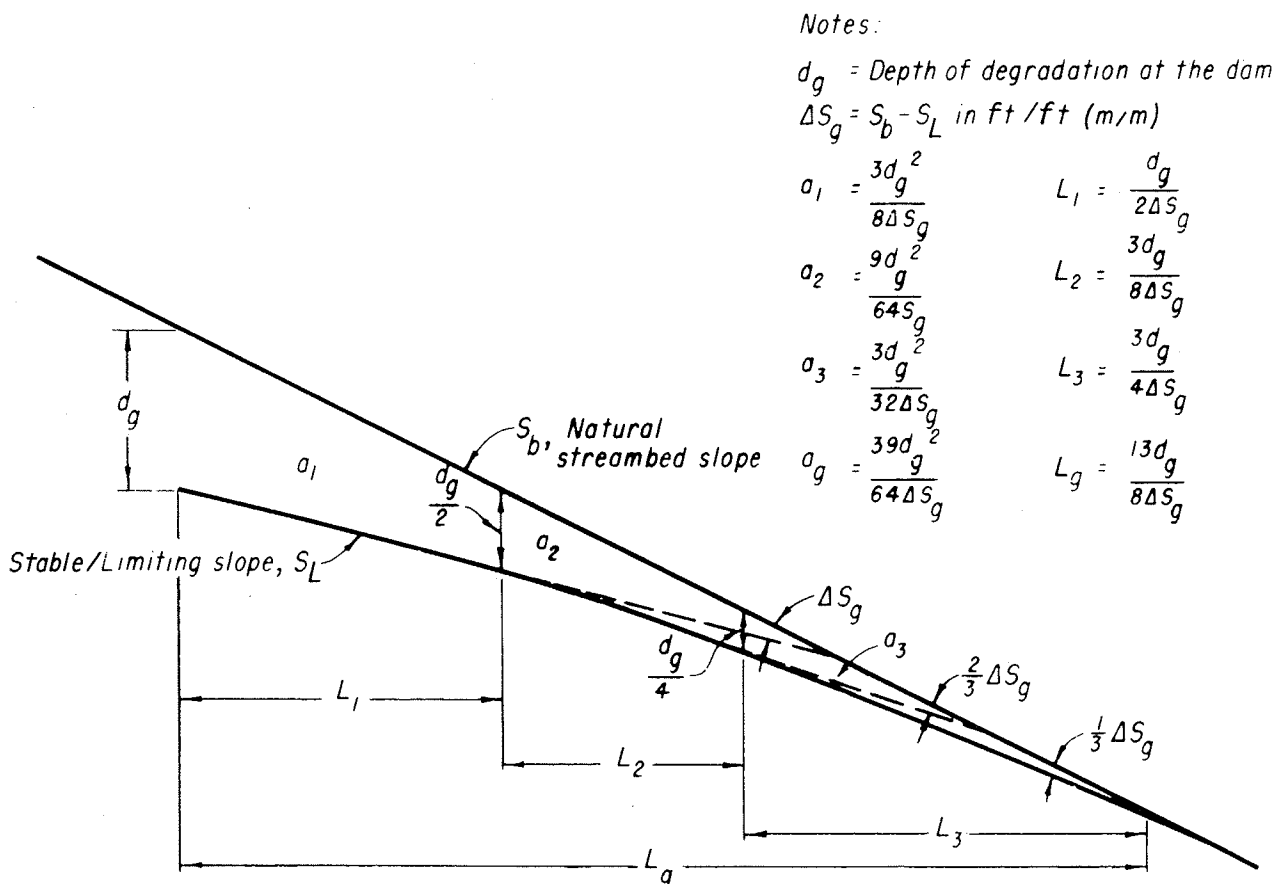

Figure 7. - Degraded channel profile - three-slope method general characteristics.

where:

a_g = Longitudinal area, ft^2 (m^2)
 V_g = Volume of degradation, ft^3 (m^3)
 B_d = Water surface width for the dominant discharge, ft (m)

The depth of degradation is computed by the equation:

$$d_g = 1.28 (\Delta S_g a_g)^{0.5} \quad (20)$$

where:

d_g = Depth of degradation, ft (m)
 ΔS_g = Difference between the existing streambed slope, S_b , and the stable slope, S_L , ft/ft (m/m)

The length of the degraded channel reach is computed by:

$$L_g = 1.625 d_g / \Delta S_g \quad (21)$$

where:

L_g = length of the degraded channel reach, ft (m)

Referring to figure 7, the degraded profile can be determined using the diagram and the equations shown to determine the length and slope for each segment of the profile.

If lateral degradation is a significant factor, a special analysis is necessary to determine the degraded channel width. Some lateral movement should be suspected where the banks are composed of similar material as the bed and do not have the necessary vegetation to resist erosion. Where lateral movement is indicated, the extent of vertical degradation generally is not as great because some of the transported material is supplied from the streambanks.

The prediction of bank erosion in a degrading reach of river usually is made by either a permissible velocity and/or tractive force methods. Criteria for determining a degraded width of channel assumes a homogeneous streambank material and that the degradation process eventually will reach a state of equilibrium. The background material for criteria used in application of either method is described by Lane (1952), Lane (1955), and Glover et al. (1951). The procedure outlined by Glover, et al. (1951) requires four basic factors: (a) the tangent of the angle of repose of the bank material, (b) critical tractive force, (c) longitudinal slope of the channel, and (d) a roughness coefficient for use in the Chezy equation. The procedure usually is more applicable to a narrow confined alluvial channel typical of a canal-type section.

The method used for most wider type river channels is to combine the criteria given by Lane (1952) for velocity and critical tractive force with actual field data and Manning's equation in the form:

Inch-pound unitsMetric units

$$Q = \frac{1.486}{n} B d^{5/3} S_L^{1/2} \quad Q = \frac{1}{n} B d^{5/3} S_L^{1/2} \text{ metric (22)}$$

The Lane (1952) reference summarizes earlier work by other investigators which included the tabulation by Fortier and Scobey (1926) of limiting velocities compared with values of tractive force for straight channels after aging and is shown in table 3. Table 3 is used primarily in a qualitative manner for comparing tractive forces and velocities for sediment laden channels versus clear water channels.

The first step in the computations for channel widening in a degrading reach of river below an upstream dam is to compute the tractive force and velocity under existing relatively stable channel conditions (with sediment) at a dominant or channel forming discharge. The reduced tractive force or velocity for clear water releases from an upstream dam can then be computed by applying an appropriate adjustment ratio from values given in table 3 or from other criteria such as given in references by Lane (1952) or ASCE (1975). The use of a tractive force adjustment is described in detail in these guidelines, although other techniques involving velocity criteria or regime relationships are considered by many investigators as equally reliable.

In the application of the tractive force method, the reduced tractive force, calculated in accordance with the changes to clear water, is used to predict a new channel cross section by combining equations 4 and 22.

In the previously cited example problem the existing tractive force from equation 4 gives:

Inch-pound unitsMetric units

$$T_C = 62.4 (1.05) (0.0014)$$

$$T_C = 1.0 (0.32) (0.0014)$$

$$T_C = 0.092 \text{ lb/ft}^2$$

$$T_C = 0.000448 \text{ t/m}^2 = 448 \text{ g/m}^2$$

If the material in the banks was "fine sand colloidal", the above tractive forces would, from table 3, be reduced by the ratio of $0.027 \div 0.075$ ($132 \div 366$ metric) = 0.36. Applying this correction to the existing tractive force gives a clear water tractive force of 0.033 lb/ft^2 (161 g/m^2). This is slightly greater than the tractive force of 0.028 lb/ft^2 (137 g/m^2) read directly from figure 4 for a $D = 0.3 \text{ mm}$ shown under Lane's tractive force method for computing a stable slope. An average adjustment ratio of 0.5 would apply to most alluvial banks of silt- and sand-size sediments.

In addition to the adjustment for clear water, a correction for sinuosity similar to that described by Lane (1952) for canals is applicable to some rivers as shown in table 4:

Table 3. - Comparison of Fortier and Scobey's limiting velocities with tractive force values (straight channels after aging) [inch-pound units (metric units)]

Material	Manning's n	For clear water		Water transporting colloidal silts	
		Velocity ft/s (m/s)	Tractive force lb/ft ² (g/m ²)	Velocity ft/s (m/s)	Tractive force lb/ft ² (g/m ²)
Fine sand colloidal	0.020	1.50 (0.457)	0.027 (132)	2.50 (0.762)	0.075 (366)
Sandy loam noncolloidal	0.020	1.75 (0.533)	0.037 (181)	2.50 (0.762)	0.075 (366)
Silt loam noncolloidal	0.020	2.00 (0.610)	0.048 (234)	3.00 (0.914)	0.11 (537)
Alluvial silts noncolloidal	0.020	2.00 (0.610)	0.048 (234)	3.50 (1.07)	0.15 (732)
Ordinary firm loam	0.020	2.50 (0.762)	0.075 (366)	3.50 (1.07)	0.15 (732)
Volcanic ash	0.020	2.50 (0.762)	0.075 (366)	3.50 (1.07)	0.15 (732)
Stiff clay very colloidal	0.025	3.75 (1.14)	0.26 (1270)	5.00 (1.52)	0.46 (2250)
Alluvial silts colloidal	0.025	3.75 (1.14)	0.26 (1270)	5.00 (1.52)	0.46 (2250)
Shales and hardpans	0.025	6.00 (1.83)	0.67 (3270)	6.00 (1.83)	0.67 (3270)
Fine gravel	0.020	2.50 (0.762)	0.075 (366)	5.00 (1.52)	0.32 (1560)
Graded loam to cobbles when noncolloidal	0.030	3.75 (1.14)	0.38 (1860)	5.00 (1.52)	0.66 (3220)
Graded silts to cobbles when colloidal	0.030	4.00 (1.22)	0.43 (2100)	5.50 (1.68)	0.80 (3910)
Coarse gravel noncolloidal	0.025	4.00 (1.22)	0.30 (1460)	6.00 (1.83)	0.67 (3270)
Cobbles and shingles	0.035	5.00 (1.52)	0.91 (4440)	5.50 (1.68)	1.10 (5370)

Table 4. - Sinuosity correction for canals

Degree of sinuosity	Tractive force (%)	Velocity (%)
Straight canals	100	100
Slightly sinuous canals	90	95
Moderately sinuous canals	75	87
Very sinuous canals	60	78

The next step in the width computations by reduced tractive force is to compute the new width, B_1 , by combining equation 4 and equation 22 which gives:

$$\begin{array}{cc}
 \text{Inch-pound units} & \text{Metric units} \\
 B_1 = \frac{661 n Q S_L^{7/6}}{T_c^{5/3}} & B_1 = \frac{n Q S_L^{7/6} \times 10^{10}}{T_c^{5/3}} \quad (23)
 \end{array}$$

In the example problem for clear water releases using the tractive force method and with no correction for sinuosity,

$$\begin{array}{cc}
 \text{Inch-pound units} & \text{Metric units} \\
 B_1 = \frac{661(0.027)(780)(0.000279)^{7/6}}{(0.033)^{5/3}} & B_1 = \frac{0.027(22.1)(0.0000713) \times 10^{10}}{(161)^{5/3}} \\
 B_1 = \frac{13.9 \times 10^3 (0.0000713)}{0.00340} = 291 \text{ ft} & B_1 = 89 \text{ m}
 \end{array}$$

The example shows that there would be a reduction in existing width of 350 ft (107 m) to 291 ft (89 m) in the upper reach where the stable slope is 0.000279. However, using figure 7 as an example of the degradation profile and breakdown into subreaches, the degraded width computations from equation 23 are shown in table 5 for the example problem. In table 5, the adjustment in tractive force from clear water to sediment laden water conditions assumes an equal change between reaches as defined by $\frac{\Delta T_c}{3}$.

Table 5. - Degraded width computations by tractive force

Reach	Slope $\frac{1}{3}$	Tractive force		B ₁ = Degraded width from equation 23	
		Adjustment ratio	c	ft	(m)
			lb/ft ² (g/m ²)		
1	0.000279	0.36	0.033 (151)	291	(89)
2	0.000653	0.57	0.053 (259)	357	(109)
3	0.00103	0.78	0.073 (356)	355	(108)
Natural channel	0.0014	1.00	0.092 (448)	350	(107)

$\frac{1}{3}$ Division of reach into three subreaches with equal change in slope as defined by $\frac{\Delta S_g}{3}$.

The final step for the example problem is the volume computations or the application of equations 12 and 19 through 23 as well as the equations shown on figure 7 for reach lengths. The annual sand (material >0.062 mm) removal is assumed to be equal to the historic sand load of 1×10^6 ft³/yr (28.3×10^3 m³/a) and the average width from table 5 equal to 354 ft (108 m). The width in reach 1 was assumed to remain at 350 ft (107 m) rather than reduced to 291 ft (89 m) as shown in table 5.

The longitudinal area in the degraded reach (see fig. 7) is computed for T = 100 years (eq. 12), where $V_g(100) = 1 \times 10^8$ ft³ (2.83×10^6 m³) by equation 19 as follows:

<u>Inch-pound units</u>	<u>Metric units</u>
$a_g = \frac{1 \times 10^8}{354} = 0.282 \times 10^6 \text{ ft}^2$	$a_g = \frac{2.83 \times 10^6}{108} = 26.2 \times 10^3 \text{ m}^2$

The depth of degradation is computed by equation 20 as follows:

<u>Inch-pound units</u>	<u>Metric units</u>
$d_g = 1.28 \left[\frac{(0.0014 - 0.000279)}{0.282 \times 10^6} \right]^{0.5}$	$d_g = 1.28 \left[\frac{(0.0014 - 0.000279)}{26.2 \times 10^3} \right]^{0.5}$
$d_g = 1.28 (17.8)$	$d_g = 1.28 (5.42)$
$d_g = 22.8 \text{ ft}$	$d_g = 6.94 \text{ m}$

The length of the degraded channel reach from equation 21 follows:

$$L_g = \frac{1.625 (22.8)}{(0.0014 - 0.000279)}$$

<u>Inch-pound units</u>	<u>Metric units</u>
$L_g = \frac{37.05}{0.00112}$	$L_g = \frac{1.625 (6.94)}{0.00112}$
$L_g = 33\ 100\ \text{ft}$	$L_g = 10\ 100\ \text{m}$

and for the subreaches:

<u>Inch-pound units</u>	<u>Metric units</u>
$L_1 = \frac{22.8}{2 (0.00112)} = 10\ 200\ \text{ft}$	$L_1 = \frac{6.94}{2 (0.00112)} = 3\ 100\ \text{m}$
$L_2 = \frac{3 (22.8)}{8 (0.00112)} = 7\ 600\ \text{ft}$	$L_2 = \frac{3 (6.94)}{8 (0.00112)} = 2\ 300\ \text{m}$
$L_3 = \frac{3 (22.8)}{4 (0.00112)} = 15\ 300\ \text{ft}$	$L_3 = \frac{3 (6.94)}{4 (0.00112)} = 4\ 700\ \text{m}$

CHANNEL SCOUR DURING PEAK FLOODFLOWS

The design of any structure located either along the riverbank and flood plain or across a channel requires a river study to determine the response of the riverbed and banks to large floods. A knowledge of fluvial morphology combined with field experience is important in both the collection of adequate field data and selection of appropriate studies for predicting the erosion potential. In most studies, two processes must be considered, (1) natural channel scour, and (2) scour induced by structures placed by man either in or adjacent to the main river channel.

Natural scour occurs in any moveable bed river but is more severe when associated with restrictions in river widths, caused by morphological channel changes, and influenced by erosive flow patterns resulting from channel alignment such as a bend in a meandering river. Rock outcrops along the bed or banks of a stream can restrict the normal river movement and thus effect any of the above influencing factors. Manmade structures can have varying degrees of influence, usually dependent upon either the restriction placed upon the normal river movement or by turbulence in flow pattern directly related to the structure. Examples of structures that influence river movement would be (1) levees placed to control flood plain flows, thus increasing main channel discharges; (2) spur dikes, groins, riprapped banks, or bridge abutments used to control main channel movement; or (3) pumping plants or headworks to canals placed on a riverbank. Scour of the bed or banks caused by these structures is that created by higher local velocities or excessive turbulence at the structure. Structures placed directly in the river consist of (1) piers and piling for either highways or railroad bridges; (2) dams across the river for diversion or storage, (3) grade control structures such as rock cascades, gabion controls or concrete baffled apron drop

structures; or (4) occasionally a powerline or tower structure placed in the flood plain but exposed to channel erosion with extreme shifting or movement of a river. All of the above may be subject to higher local velocities, but usually are subject to the more critical local scour caused by turbulence and helicoidal flow patterns.

The prediction of river channel scour due to floods is necessary for the design of many Reclamation structures. These Reclamation guidelines on scour represent a summary of some of the more applicable techniques which are described in greater detail in the reference publications by T. Blench (1969), National Cooperative Highway Research Program Synthesis 5 (1970), C. R. Neill (1973), D. B. Simons and F. Senturk (1977), and S. C. Jain (1981). The paper by S. C. Jain (1981) summarized many of the empirical equations developed for predicting scour of a streambed around a bridge pier. It should be recognized that the many equations are empirically developed from experimental studies. Some are regime-type based on practical conditions and considerable experience and judgment. Because of the complexity of scouring action as related to velocity, turbulence, and bed materials, it is difficult to prescribe a direct procedure. Reclamation practice is to compute scour by several methods and utilize judgment in averaging the results or selection of the most applicable procedures.

The equations for predicting local channel scour usually can be grouped into those applicable to the two previously described processes of either a natural channel scour or scour caused by a manmade structure. A further breakdown of these processes is shown in table 6 where Type A equations are those used for natural river erosion and Types B, C, and D cover various manmade structures.

The importance of experience and judgment in conducting a scour study cannot be overemphasized. It should be recognized that the techniques described in these guidelines merely provide a set of practical tools in guiding the investigator to estimate the amount of scour for use in design. The collection of adequate field data to define channel hydraulics and bed or bank materials to be scoured govern the accuracy of any study. They should be given as much emphasis as the methodology used in the analytical study. Field data are needed to compute water surface profiles for a reach of river in the determination of channel hydraulics for use in a scour study. With no restrictions in channel width, scour is computed from the average channel hydraulics for a reach. If a structure restricts the river width, scour is computed from the channel hydraulics at the restriction. In all cases, scour estimates should be based upon the portion of discharge in and hydraulic characteristics of the main channel only.

Table 6. - Classification of scour equation for various structure designs

Equation type	Scour	Design
A	Natural channel for restrictions and bends	Siphon crossing or any buried pipeline. Stability study of a natural bank. Waterway for one-span bridge.
B	Bankline structures	Abutments to bridge or siphon crossing. Bank slope protection such as riprap, etc. Spur dikes, groins, etc. Pumping plants. Canal headworks.
C	Midchannel structures	Piling for bridge. Piers for flume over river. Powerline footings. Riverbed water intake structures.
D	Hydraulic structures across channel	Dams and diversion dams. Erosion controls. Rock cascade drops, gabion controls, and concrete drops.

Although each scour problem must be analyzed individually, there are some general flow and sediment transport characteristics to be considered in making the judgmental decision on methodology. The general conclusion reached by Lane and Borland (1954) was that floods do not cause a general lowering of streambed, and rivers such as the Rio Grande may scour at the narrow sections but fill up at the wider downstream sections during a major flood. Another general sediment transport characteristic is the influence of a large sediment load on scour which includes the variation of sediment transport associated with a high peak, short duration flood hydrograph. The large sediment concentrations usually of clay and silt size material will occur on the rising stage of the hydrograph up and through the peak of the flood while the falling stage of the flood with deposition of coarser sediments in the bed of the channel may be accompanied by greater scour of the wetted channel banks. Channel scour also occurs when the capacity of streamflow with extreme high velocities in portions of the channel cross section will transport the bed material at a greater rate than replacement materials are supplied. Thus, maximum depth of channel scour during the flood is a function of the channel geometry, obstruction created by a structure (if any), the velocity of flow, turbulence, and size of bed material.

Design Flood

The first step in local scour study for design of a structure is selection of design flood frequency. Reclamation criteria for design of most structures

shown in table 6 varies from a design flood estimated on a frequency basis from 50 to 100 years. This pertains to an adequate waterway for passage of the floodflow peak. The scour calculations for these same structures are always made for a 100-year flood peak. The use of the 100-year flood peak for scour is based on variability of channel hydraulics, bed material, and general complexity of the erosive process. The exception in the use of the 100-year flood peak for estimating scour would be the scour hole immediately below a large dam or a major structure where loss of structure could involve lives or represent a catastrophic event. In this case, the scour for use in design should be determined for a flow equal to 50 percent of the structure design flood.

Equation Types A and B (See Table 6)

Natural river channel scour estimates are required in design of a buried pipe, buried canal siphon, or a bankline structure. For most siphon crossings of a river, the cost of burying a siphon will dictate either the selection of a natural narrow reach of river or a restriction in width created by constructing canal bankline levees across a portion of the flood plain. A summary of available methods for computing scour at constrictions is given by Neill (1973). The four methods for estimating general scour at constricted waterways described by Neill (1973) are considered the proper approach for estimating scour for use in either design of a siphon crossing or where general scour is needed of the riverbed for a bankline structure. The four methods supplemented with Reclamation's procedure for application are given below:

Field measurements of scour method. - This method consists of observing or measuring the actual scoured depths either at the river under investigation or a similar type river. The measurements are taken during as high a flow as possible to minimize the influence of extrapolation.

A Reclamation unpublished study by Abbott (1963) analyzed U.S. Geological Survey discharge measurement notes from several streams in the southwestern United States, including the Galisteo Creek at Domingo, New Mexico, and developed an empirical curve enveloping observed scour at the gaging station. This envelope curve for use in siphon design was further supported by observed scour from crest-stage and scour gages on Gallegos, Kutz, Largo, Chaco, and Gobernador Canyons in northwest New Mexico collected during the period from 1963 to 1969. The scour gages consisted of a series of deeply anchored buried flexible tapes across the channel section that were resurveyed after a flood to determine the depth of scour at a specific location. The results of these measurements are shown on figure 8 along with the envelope curve for Galisteo Creek that support scour estimates for wide sandbed (D_{50} varying from 0.5 to 0.7 mm) ephemeral streams in the southwestern United States by the equation.

$$d_s = K (q)^{0.24} \quad (24)$$

where:

- d_s = Depth of scour below streambed, ft (m)
- K = 2.45 inch-pound units (1.32 metric units)
- q = Unit water discharge, ft^3/s per ft of width (m^3/s per m of width)

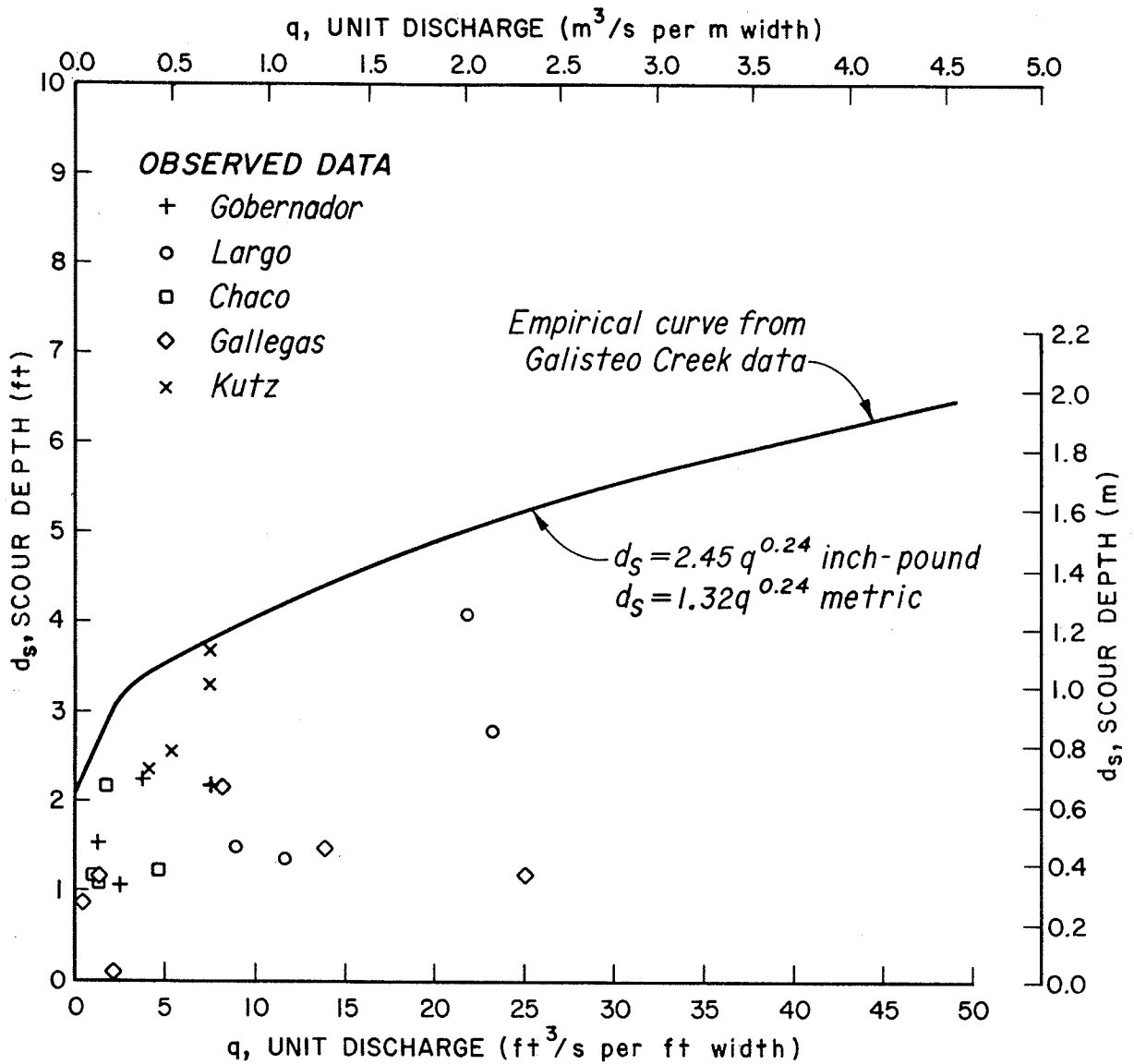

Figure 8. - Navajo Indian Irrigation Project - scour versus unit discharge.

The use of equation 24 except as a check on other methods would be limited to channels similar to those observed on relatively steep slopes ranging from 0.004 to 0.008 ft/ft (m/m). Because of shallow depths of flow and medium to coarse sand size bed material the bedload transport should also be very high.

Regime equations supported by field measurements method. - This approach as suggested by Neill (1973) on recommendations by Blench (1969) involves obtaining field measurements in an incised reach of river from which the bankfull discharge and hydraulics can be determined. From the bankfull hydraulics in the incised reach of river, the flood depths can be computed by:

$$d_f = d_i \left(\frac{q_f}{q_i} \right)^m \quad (25)$$

where:

- d_f = Scoured depth below design floodwater level
- d_i = Average depth at bankfull discharge in incised reach
- q_f = Design flood discharge per unit width
- q_i = Bankfull discharge in incised reach per unit width
- m = Exponent varying from 0.67 for sand to 0.85 for coarse gravel

This method has been expanded for Reclamation use to include the empirical regime equation by Lacey (1930) and the method of zero bed-sediment transport by Blench (1969) in the form of the Lacey equation:

$$d_m = 0.47 \left(\frac{Q}{f} \right)^{1/3} \quad (26)$$

where:

- d_m = Mean depth at design discharge, ft (m)
- Q = Design discharge, ft³/s (m³/s)
- f = Lacey's silt factor equals 1.76 (D_m)^{1/2} where D_m equal mean grain size of bed material in millimeters

and the Blench equation for "zero bed factor":

$$d_{fo} = \frac{q_f^{2/3}}{F_{bo}^{1/3}} \quad (27)$$

where:

- d_{fo} = Depth for zero bed sediment transport, ft (m)
- q_f = Design flood discharge per unit width, ft³/s per ft (m³/s per m)
- F_{bo} = Blench's "zero bed factor" in ft/s² (m/s²) from figure 9

The maximum natural channel scour depth for design of any structure placed below the streambed (i.e., siphon) or along the bank of a channel must

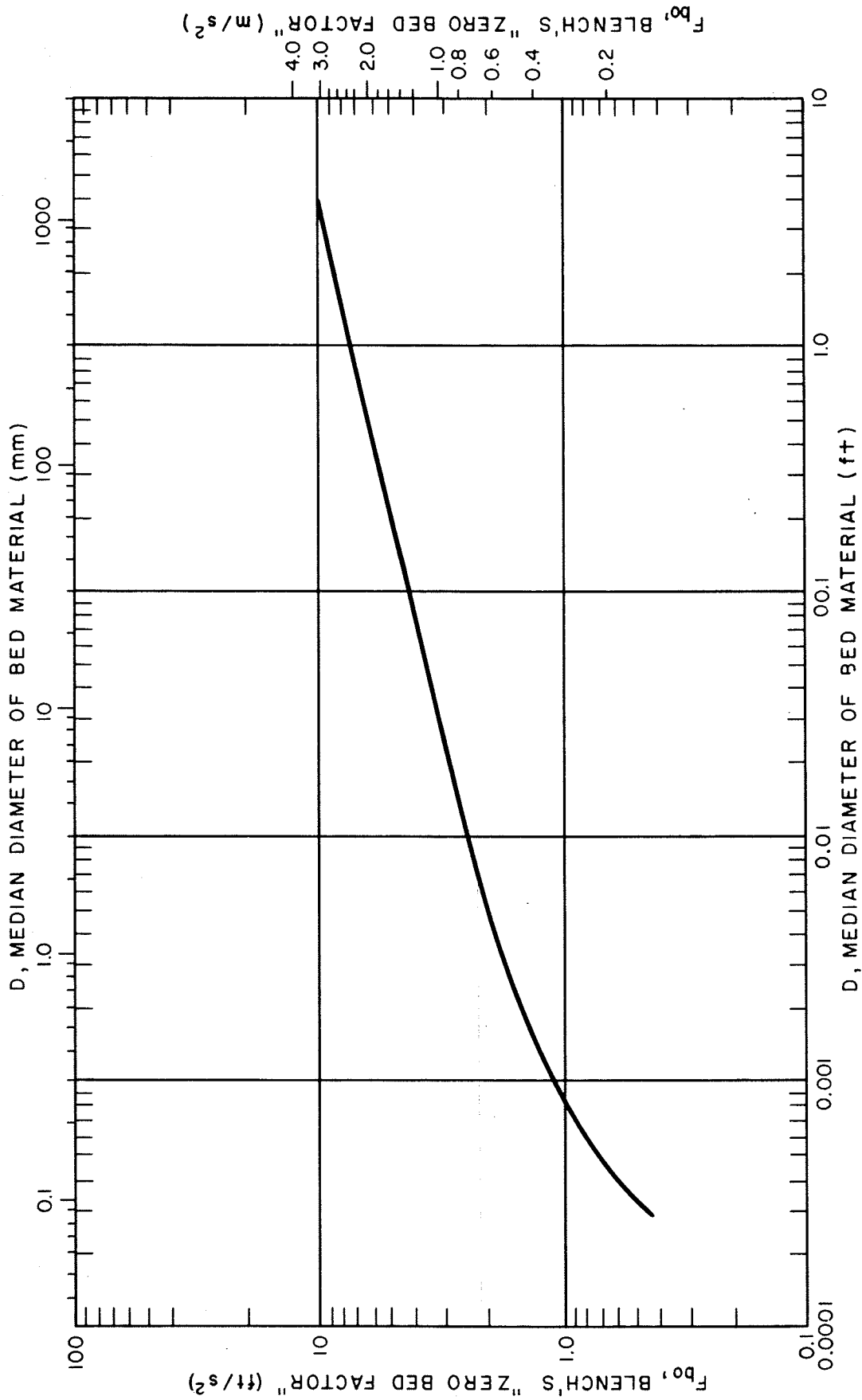

CHART FOR ESTIMATING F_{bo} (AFTER BLENCH)

Figure 9. - Chart for estimating F_{bo} (after Blench, 1969).

consider the probable concentration of floodflows in some portion of the natural channel. Equations 25, 26, or 27 for predicting this maximum depth are to be adjusted by the empirical multiplying factors, Z, shown for formula Types A and B (table 6), in table 7. An illustration of maximum scour depth associated with a flood discharge is shown in a sketch of a natural channel, figure 10. As shown in table 7 and on figure 10, the d_s equals depth of scour below streambed.

$$d_s = Z d_f \quad (28)$$

$$d_s = Z d_m \quad (29)$$

$$d_s = Z d_{fo} \quad (30)$$

Table 7. - Multiplying factors, Z, for use in scour depths by regime equations

Condition	Value of Z		
	Neill $d_s = Z d_f$	Lacey $d_s = Z d_m$	Blench $d_s = Z d_{fo}$
<u>Equation Types A and B</u>			
Straight reach	0.5	0.25	} $\frac{1}{0.6}$ 1.25
Moderate bend	0.6	0.5	
Severe bend	0.7	0.75	
Right angle bends		1.0	
Vertical rock bank or wall		1.25	
<u>Equation Types C and D</u>			
Nose of piers	1.0		0.5 to 1.0
Nose of guide banks	0.4 to 0.7	1.50 to 1.75	1.0 to 1.75
Small dam or control across river		1.5	0.75 to 1.25

1/ Z value selected by USBR for use on bends in river.

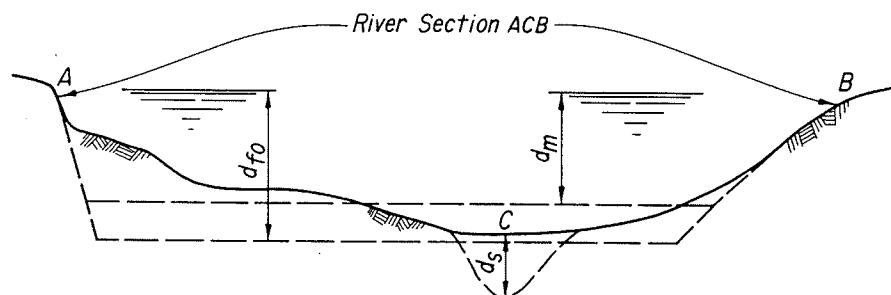

NOTE: $d_{fo} > d_f > d_m$. Point C is low point of natural section.

Figure 10. - Sketch of natural channel scour by regime method.

Although not shown on figure 10, the d_f from Neill's equation 25 is usually less than the d_{f0} from Blench's equation 27 but greater than the d_m from Lacey's equation 26.

The design of a structure under a river channel such as a siphon is based on applying the scoured depth, d_s , as obtained from table 7 to the low point in a surveyed section, as shown by point C on figure 10. This criteria is considered by Reclamation as an adequate safety factor for use in design. In an alluvial streambed, designs should also be based on scour occurring at any location in order to provide for channel shifting with time.

Mean velocity from field measurements method. - This approach represents an adjustment in surveyed channel geometry based on an extrapolated design flow velocity. In Reclamation's application of this method, a series of at least four cross sections are surveyed and backwater computations made for the design discharge by use of Reclamation's Water Surface Profile Computer Program. In addition to the surveyed cross sections observed, water surface elevations at a known or measured discharge are needed to provide a check on Manning's "n" channel roughness coefficient. This procedure allows for any proposed waterway restrictions to be analyzed for channel hydraulic characteristics including mean velocity at the design discharge. The usual Reclamation application of this method is to determine the mean channel depth, d_m , from the computer output data and apply the Z values defined by Lacey in table 7 to compute a scour depth, d_s , by equation 29 where $d_s = Z d_m$.

Examples of more unique solutions to scour problems were Reclamation studies on the Colorado River near Parker, Arizona, and Salt River near Granite Reef Diversion Dam, Arizona, where an adjustment in "n" based on particle size along with a Z value from table 7 provided a method of computing bed scour. The selection of a particle size "n" associated with scour in the above two examples was computed from the Strickler (1923) equation for roughness of a channel based on diameter of particles where:

$$K = \frac{C}{D_{90}^{1/6}} \quad (31)$$

$C \approx 26$ from Nikuradse (1933) and "n" = 1/K. The appropriate "n" values for the two rivers based on particle size and engineering judgment were selected as follows:

<u>River</u>	<u>D (mm)</u>	<u>Particle size "n"</u>	<u>Selected "n"</u>
Colorado	0.2	0.01	0.014
Salt	18	0.02	0.02

In the Colorado River study, the existing channel "n" value of 0.022 was adjusted down to 0.014 due to bed material particle size to give a computed water surface at design discharge representative of a scoured channel. With a Z value of 0.5, the scoured section in the form of a triangular section combined with the accepted "n" of 0.022 provided a close check on the water surface computed without scour. An illustration

of this technique is shown in sketch on figure 11a. Another example is shown on figure 11b for a Salt River scour study where the particle size "n" of 0.02 gave a reduced mean depth. Scour was assumed to be in the shape of a triangle where the average depth of scour would be equal the depth at an "n" equal to 0.02 subtracted from depth at an "n" equal to 0.03. (See example problem in subsequent paragraph.)

Competent or limiting velocity control to scour method. - This method assumes that scour will occur in the channel cross section until the mean velocity is reduced to that where little or no movement of bed material is taking place. It gives the maximum limit to scour existing in only the deep scour hole portion of the channel cross section and is similar to the Blench equation 27 for a "zero bed factor."

The empirical curves, figure 12, derived by Neill (1973) for competent velocity with sand or coarser bed material (>0.30 mm) represent a combining of regime criteria, Shields (1936) criterion for material >1.0 mm, and a mean velocity formula relating mean velocity V_m to the shear velocity. The competent velocities for erosion of cohesive materials recommended by Neill (1973) are given in table 8. The scour depth or increase in area of scoured channel section with corresponding increase in depth for competent velocity, V_c , is determined by relationship of mean velocity, V_m , to V_c in the equation:

$$d_s = d_m \left(\frac{V_m}{V_c} - 1 \right) \quad (32)$$

where:

d_s = Scour depth below streambed, ft (m)
 d_m = Mean depth, ft (m)

Table 8. - Tentative guide to competent velocities for erosion of cohesive materials* (after Neill, 1973)

Depth of flow ft m		Competent mean velocity					
		Low values - easily erodible material		Average values		High values - resistant material	
		ft/s	m/s	ft/s	m/s	ft/s	m/s
5	1.5	1.9	0.6	3.4	1.0	5.9	1.8
10	3	2.1	0.65	3.9	1.2	6.6	2.0
20	6	2.3	0.7	4.3	1.3	7.4	2.3
50	15	2.7	0.8	5.0	1.5	8.6	2.6

* Notes: (1) This table is to be regarded as a rough guide only, in the absence of data based on local experience. Account must be taken of the expected condition of the material after exposure to weathering and saturation. (2) It is not considered advisable to relate the suggested low, average, and high values to soil shear strength or other conventional indices, because of the predominating effects of weathering and saturation on the erodibility of many cohesive soils.

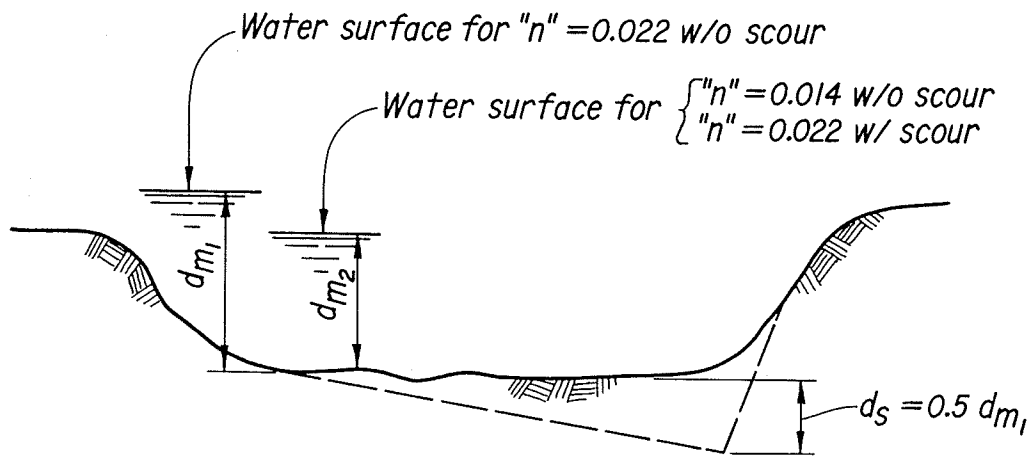

a. Colorado River Study

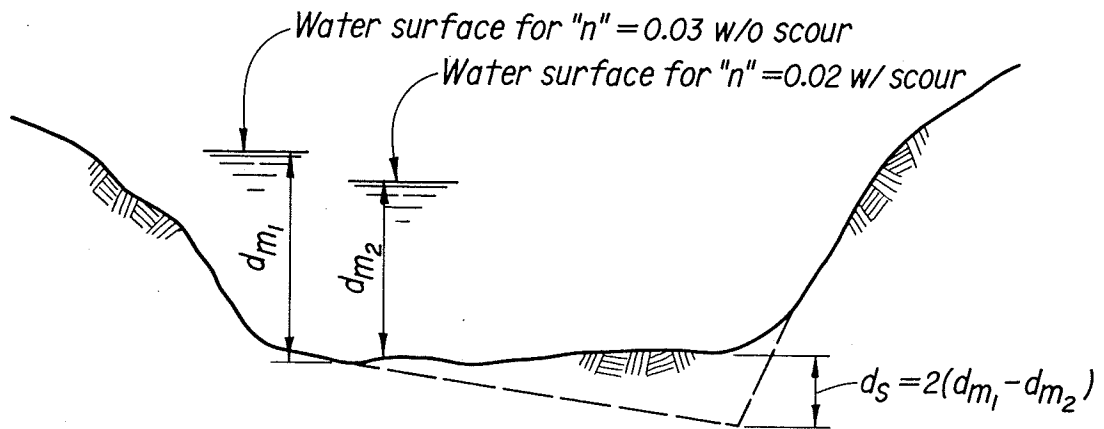

b. Salt River Study

Figure 11. - Sketch of scour from water surface profile computations and reduced "n" for scour.

The use of figure 12 and table 8 recommended by Neill (1973) has had limited application in Reclamation, but appears to be a potential useful technique for many Reclamation studies on scour and armoring of the channel.

Equation Type C (See Table 6)

The principal references for design of midchannel structures for scour such as at bridge piers are National Cooperative Highway Research Program Synthesis 5 (1970), C. R. Neill (1973), Federal Highway Administration, Training and Design Manual (1975), Federal Highway Administration (1980), and S. C. Jain (1981). The numerous empirical relationships for computing scour at bridge piers include one or more of the following hydraulic parameters: pier width and skewness, flow depth, velocity, and size of sediment. The many relations available were further broken down by Jain (1981) to two different approaches: (1) regime, and (2) rational.

The Federal Highway Administration has funded numerous research projects to assist in improving their designs of bridge piers. This research has not resulted in any one recommended procedure. Reclamation's need for scour estimates at midchannel structures is limited. The procedures adopted are to try at least two techniques and apply engineering judgment in selecting an average or most reliable method. The regime approach is to use either equations 26, 27, 28, or 30 and a Z value from table 7. An appropriate Z value to use for piers is 1.0 as found for the railway bridge piers applied to the Lacey equation 29 reported by Central Board of Irrigation and Power (1971).

The rational equation selected for scour at piers is described by Jain (1981) in the form:

$$\frac{d_s}{b} = 1.84 \left(\frac{d}{b}\right)^{0.3} (F_c)^{0.25} \quad (33)$$

where:

- d_s = Depth of scour below streambed, ft (m)
- b = Pier size, ft (m)
- d = Flow depth, ft (m)
- $F_c = V_c / \sqrt{gd}$ = Threshold Froude number
- V_c = Threshold velocity, ft/s (m/s) from figure 12
- g = Acceleration due to gravity, 32.2 ft/s² (9.81 m/s²)

Equation Type D (See Table 6)

Immediately downstream from any hydraulic structure the riverbed is subject to the erosive action created by the structure. Some type of stilling basin or energy dissipator as described by Reclamation (1977) is provided in the design of such structures to dissipate the energy thereby reducing the erosion potential. There still remains at most structures, below the point where the structure ends and the natural riverbed material begins, a potential for scour. The magnitude of this scour hole will depend on a combination of flow velocity, turbulence, and vortices generated by the structure. Simons and Senturk (1977) describe many of the available equations.

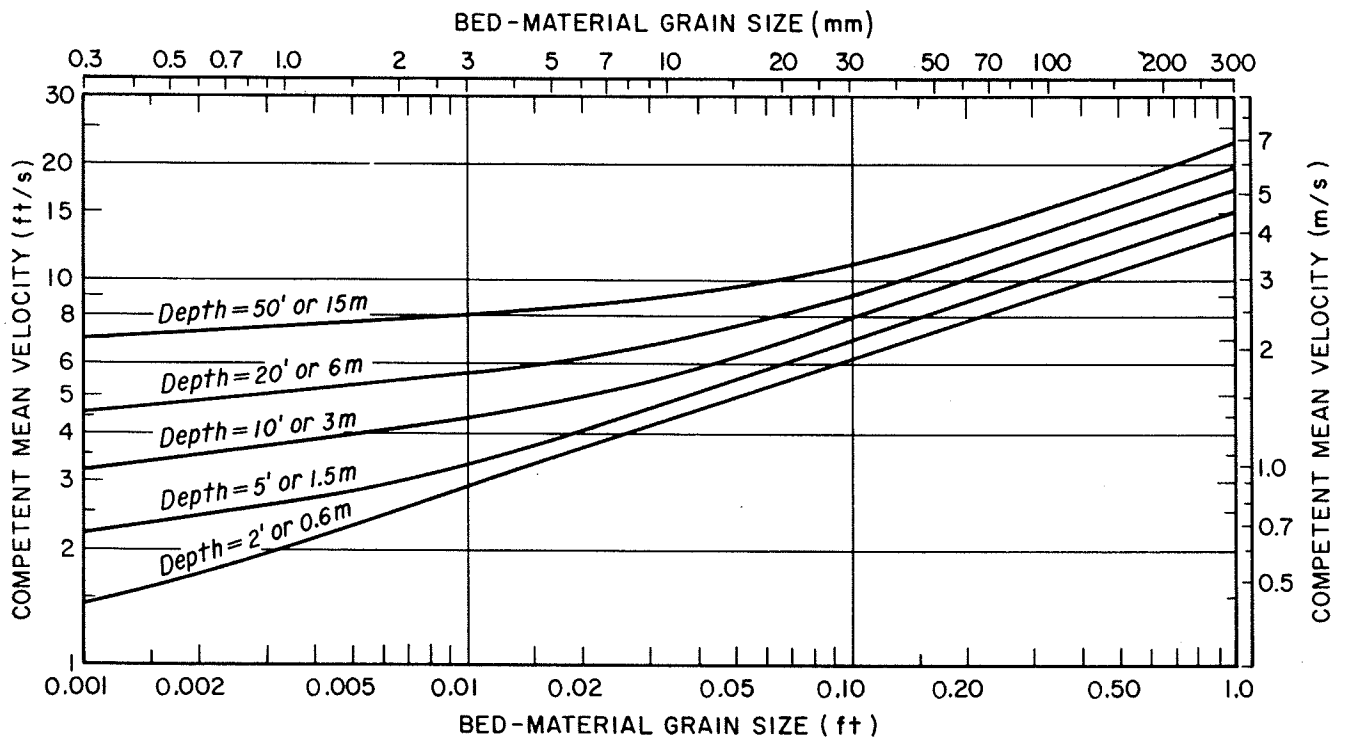

Figure 12. - Suggested competent mean velocities for significant bed movement of cohesionless materials, in terms of grain size and depth of flow (after Neill, 1973).

Methods adopted by Reclamation for computing local scour below a hydraulic structure across the river channel are based on either the regime or rational approach. Scour computations should be made by several methods and engineering judgment used to select the most appropriate. In the regime approach, the Lacey or Blench equations 26, 27, 29, and 30, respectively, with Z values from table 7 are applicable.

The most appropriate empirically developed rational methods for scour below a structure are those by Schoklitsch (1932), Veronese (1937), or Zimmerman and Maniak (1967). Scour computations by Schoklitsch are made by:

$$d_s = \frac{K (H)^{0.2} q^{0.57}}{D_{90}^{0.32}} - d_m \quad (34)$$

where:

- d_s = Depth of scour below streambed, ft (m)
- K = 3.15 inch-pound units ($K = 4.70$ metric units)
- H = Vertical distance between the water level upstream and downstream of the structure, ft (m)
- q = Design discharge per unit width, ft³/s per ft (m³/s per m)
- D_{90} = Particle size for which 90 percent is finer than, mm
- d_m = Downstream mean water depth, ft (m)

The Veronese (1937) equation for computing the scour hole depth below a low head stilling basin design is as follows:

$$d_s = K H_T^{0.225} q^{0.54} - d_m \quad (35)$$

where:

- d_s = Maximum depth of scour below streambed, ft (m)
- K = 1.32 inch-pound units ($K = 1.90$ metric units)
- H_T = The head from upstream reservoir to tailwater level, ft (m)
- q = Design discharge per unit width, ft³/s per ft (m³/s per m)
- d_m = Downstream mean water depth, ft (m)

The Zimmerman and Maniak (1967) equation for local scour below a stilling basin can be calculated by:

$$d_s = K \left(\frac{q^{0.82}}{D_{85}^{0.23}} \right) \left(\frac{d_m}{q^{2/3}} \right)^{0.93} - d_m \quad (36)$$

where:

- d_s = Depth of scour below streambed, ft (m)
- K = 1.95 inch-pound units ($K = 2.89$ metric units)
- q = Design discharge per unit width, ft³/s per ft (m³/s per m)
- D_{85} = Particle size for which 85 percent is finer than, mm
- d_m = Downstream mean water depth, ft (m)

Example Problem

A scour study was prepared for a reach of the Salt River channel downstream from the existing Granite Reef Diversion Dam and near the Granite Reef Aqueduct which serves as an example of the different methods for computing scour during a design peak flood. These example computations are shown in table 9. The channel hydraulics represent an arithmetic average from water surface profile computations using six sections on the river defining a reach length of 6850 ft (2090 m). To show the many different methods for computing local scour occurring during a flood, several hypothetical situations are used such as a bridge pier, 10-ft (3.05-m) wide and a control structure with a design head, $H = 5$ ft (1.52 m). A summary of the results is given in table 10.

Table 10. - Summary of channel scour during a floodflow on Salt River

Design	d_s - scour below streambed	
	ft	m
Siphon or bankline structure with minor restriction (A and B)	8.99	2.74
Bridge pier or spur dike from bank (C)	12.2	3.72
Below control structure across river (D)	11.6	3.54

CONCLUSIONS

These guidelines describe the procedures available for computing general river channel degradation and local scour during peak floodflows for use in design of Reclamation structures. Recommendation of a specific method for prediction of either channel degradation or local scour is difficult because of the complexity and variability of the many parameters influencing the erosive action of a river channel. Factors such as river discharges, channel hydraulic characteristics, velocities, turbulence, bedload transport, suspended sediment, bed material size, gradation, and natural rock controls all affect the degradation and erosion process. Most procedures described are empirically developed in laboratory studies with a limited amount of field data on measurement of scour to verify the results. Because of the complexities involved in defining the parameters to use in the equations and variability in results, Reclamation recommended procedure is to try several methods and from experience and engineering judgment select the techniques and results most applicable to the problem.

The field data needed to define the parameters in many equations are critical in the selection and application of a specific procedure. Because of the importance in collection of field data, these guidelines include a description of the appropriate bed material sampling techniques. Through experience investigators continue to emphasize the importance of collecting appropriate field data which governs the accuracy of any analytical study and should be given as much emphasis as the methodology used in the analytical study.

REFERENCES

- ASCE (1975), "Sedimentation Engineering," Manual No. 54.
- Abbott, P. O. (1963), "Scour Study for Navajo Indian Irrigation Project," USBR memorandum.
- Blench, T. (1969), "Mobile-Bed Fluviology", Edmonton: University of Alberta Press.
- Bureau of Reclamation (1955), "Step Method for Computing Total Sediment Load by the Modified Einstein Procedure," Denver, Colorado.
- Bureau of Reclamation (1957), "Guide for Computing Water Surface Profiles."
- Bureau of Reclamation (1966), "Computation of 'Z's' for Use in the Modified Einstein Procedure, Denver, Colorado.
- Bureau of Reclamation (1977), "Design of Small Dams."
- Central Board of Irrigation and Power (1971), "River Behavior Control and Training," India.
- Colby, B. R., and C. H. Hembree (1955), "Computations of Total Sediment Discharge, Niobrara River near Cody, Nebraska," U.S. Department of the Interior, Geological Survey Water Supply Paper No. 1357.
- Corps of Engineers (1977), "Scour and Deposition on Rivers and Reservoirs," HEC-6 Users Manual for a Generalized Computer Program, Exhibit 3.
- Federal Highway Administration, (1975) "Training and Design Manual."
- Federal Highway Administration (1980), "Scour Around Bridge Piers."
- Federal Inter-Agency Sedimentation Project (1963), A study of methods used in measurement and analysis of sediment loads in streams, report No. 14, determination of fluvial sediment discharge, St. Anthony Falls Hydraulic Laboratory, Minneapolis, Minnesota.
- Fortier, S., and F. C. Scobey (1926), "Permissible Canal Velocities," Transactions, ASCE, vol. 89.
- Glover, R., Q. Florey, and W. W. Lane (1951), "Stable Channel Profiles," Hydraulic Laboratory Report No. Hyd-325, U.S. Department of the Interior, Bureau of Reclamation.
- Jain, S. C. (1981), "Maximum Clear-Water Scour Around Circular Piers," Journal of the Hydraulics Division, ASCE.
- Kellerhals, R. (1967), "Stable Channels with Gravel-Based Beds," Journal of the Waterways and Harbors Division, ASCE, vol. 93.
- Kellerhals, R., and D. I. Bray (1971), "Sampling Procedures for Coarse Fluvial Sediments," Journal Hydraulic Division, ASCE.

Table 9. - Example problem - Salt River scour study below Granite Reef Diversion Dam

Given data:		Inch-pound units	Metric units		
Q, design discharge	=	110,000 ft ³ /s	(3110 m ³ /s)		
B, channel width	=	990 ft	(302 m)		
d _m , mean water depth	=	12.4 ft	(3.78 m)		
A, water area	=	12,300 ft ²	(1140 m ²)		
V _m , mean velocity	=	8.94 ft/s	(2.73 m/s)		
q, discharge per unit width	=	111 ft ³ /s/ft	(10.3 m ³ /s/m)		
D, bed material size		D ₅₀ = 18 mm			
		D ₈₅ = 23.5 mm			
		D ₉₀ = 25 mm			

Equation type	Method	No.	Equations	Computations	d _s - scour ft (m)
A and B	USBR	(24)	(Not considered applicable because of bed material size and extrapolation of curve in figure 8.)		
	Lacey	(26)	d _m = 0.47 (q/f) ^{1/3} f = 1.76 (D ₅₀) ^{1/2} f = 7.47	d _m = 0.47 (110,000/7.47) ^{1/3} = 11.5 (d _m = 0.47 (3110/7.47) ^{1/3} = 3.51)	
		(29)	d _s = 0.75 d _m (Severe bend - table 7) Z = 0.75	d _s = 0.75 (11.5) (d _s = 0.75 (3.51))	8.63 (2.63)
	Blench	(27)	d _{fo} = K (q _f ^{2/3} / F _{bo} ^{1/3}) F _{bo} = 3.6 (fig. 9) (F _{bo} = 1.1) F _{bo} ^{1/3} = 1.53 (F _{bo} ^{1/3} = 1.03)	d _{fo} = (23.1 / 1.53) = 15.1 (d _{fo} = (4.73 / 1.03) = 4.59)	
		(30)	d _s = 0.6 d _{fo}	d _s = 0.6 (15.1) (d _s = 0.6 (4.59))	9.06 (2.75)
	USBR	(29)	d _s = Z d _m	d _s = 0.75 (12.4) (d _s = 0.75 (3.78))	9.30 (2.84)
	Neill	(32)	d _s = d (V _m / V _c - 1) V _c from figure 12 V _c = 7.0 ft/s (2.13 m/s)	d _s = 12.4 (8.94 / 7 - 1) (d _s = 3.78 (2.73 / 2.13 - 1))	3.4 (0.45)
	Average		Average = 8.63 + 9.06 + 9.30 + 3.4* + 3 (2.63 + 2.75 + 2.84 + 1.06* + 3) * disregard in averaging		8.99 (2.74)
C	Lacey	(29)	d _s = 1.0 d _m	d _s = 1.0 (11.5) (d _s = 1.0 (3.51))	11.5 (3.51)
Bridge pier with assumed pier width b = 10 ft (3.05 m)	Blench	(30)	d _s = 0.7 d _{fo} Z = 0.7 for pier	d _s = 0.7 (15.1) (d _s = 0.7 (4.59))	10.6 (3.21)
	Jain	(34)	d _s = b [1.84 (d _m /b) ^{0.3} (F _c) ^{0.25}] F _c = V _c / (gd) ^{1/2} V _c from figure 12 F _c = 7.0 / (32.2 x 21.4) ^{1/2} = 0.3	d _s = 10 [1.84 (1.24) ^{0.3} (0.3) ^{0.25}] d _s = 10 (1.46) (d _s = 3.05 [1.84 (1.24) ^{0.3} (0.3) ^{0.25}])	14.6 (4.45)
	Average		Average = 11.5 + 10.6 + 14.6 + 3 (3.51 + 3.21 + 4.45 + 3)		12.2 (3.72)
D	Schoklitsch	(34)	d _s = K (H) ^{0.2} q ^{0.57} / D ₉₀ ^{3/2} - d _m Assume H = 5 ft (H = 1.52 m)	d _s = 3.15 (5) ^{0.2} (111) ^{0.57} / (25) ^{0.32} - 12.4 d _s = 3.15 (7.20) - 12.4 d _s = 22.7 - 12.4 (d _s = 4.7 (1.52) ^{0.2} (10.3) ^{0.57} / 2.8 - 3.78)	10.3 (3.14)
	Veronese	(35)	d _s = K H ₁ ^{0.225} q ^{0.54} - d _m	d _s = 1.32 (5) ^{0.225} (111) ^{0.54} - 12.4 d _s = 24.2 - 12.4 (d _s = 1.9 (1.52) ^{0.225} (10.3) ^{0.54} - 3.78)	11.8 (3.58)
	Zimmerman and Maniak	(36)	d _s = K (q ^{0.82} / D ₈₅ ^{0.23}) (d _m / q ^{2/3}) ^{0.93} - d _m	d _s = 1.95 (111 ^{0.82} / 23.50.23) (12.4 / 111 ^{2/3}) ^{0.93} - 12.4 d _s = 1.95 (47.6 / 2.07) (12.4 / 23.1) ^{0.93} - 12.4 d _s = 1.95 (23.0) (0.561) - 12.4 (d _s = 2.89 (10.30.82 / 2.07) (3.78) ^{0.93} - 3.78)	12.8 (3.89)
	Average		Average = 10.3 + 11.8 + 12.8 + 3 (3.14 + 3.58 + 3.89 + 3)		11.6 (3.54)

1/ All computations given in inch-pound units except those given in parenthesis, which indicate metric units.

- Lacey, G. (1930), "Stable Channels in Alluvium," in Proceedings of the Institution of Civil Engineers, vol. 229.
- Lane, E. W. (1948), "An Estimate of the Magnitude of the Degradation Which will Result in the Middle Rio Grande Channel from the Construction of the Proposed Sediment Storage Basins and Contraction Works," U.S. Department of the Interior, Bureau of Reclamation.
- Lane, E. W. (1952), "Progress Report on Results of Studies on Design of Stable Channels," HYD-352, Bureau of Reclamation.
- Lane, E. W. (1955), "The Importance of Fluvial Morphology in Hydraulic Engineering," Proceedings, ASCE, vol. 81.
- Lane, E. W. (1955), "Design of Stable Channels", Transactions, ASCE, vol. 120.
- Lane, E. W., and W. M. Borland (1954), "River-Bed Scour During Floods," Paper No. 2712, Transactions, ASCE, vol. 119.
- Lara, J. M., and E. L. Pemberton (1965), "Initial Unit Weight of Deposited Sediments," Proceedings of Federal Inter-Agency Sedimentation Conference, 1963, Miscellaneous Publication No. 970, USDA, ARS.
- Leopold, L. B. (1970), "An Improved Method for Size Distribution of Stream Bed Gravel," Water Resources Research, vol. 6.
- Mavis, F. T., and L. M. Laushey (1948), "A Reappraisal of the Beginning of Bed-Movement-Competent Velocity," International Association for Hydraulic Research, Second Meeting, Stockholm.
- Mengis, R. C. (1981), "Modeling of a Transient Streambed in the Rio Grande, Cochiti Dam to Near Albuquerque, New Mexico," U.S. Geological Survey Open-File Report 82-106.
- Meyer-Peter, E., and R. Muller (1948), "Formulas for Bed-Load Transport," International Association for Hydraulic Structure, Second Meeting, Stockholm.
- National Cooperative Highway Research Program Synthesis 5 (1970), "Scour at Bridge Waterways," Highway Research Board.
- Neill, C. R. (1973), "Guide to Bridge Hydraulics", Published for Roads and Transportation Association of Canada.
- Nikuradse, V.D.J. (1933), Forschungsheft 361, Berlin, "Stromungsgesetze in rauhen Rohren."
- Rubey, W. W. (1933), "Settling Velocities of Gravel, Sand, and Silt Particles," American Journal of Science, Fifth Series, vol. XXV, No. 148.
- Schoklitsch (1932), "Prevention of Scour and Energy Dissipation," translated from German by E. F. Wilsey, USBR.

- Sheppard, John R. (1960), "Investigation of Meyer-Peter, Muller Bedload Formulas," Bureau of Reclamation.
- Shields, A. (1936), "Anwendung der Aenlichkeitsmechanik und der Turbulenzforschung anf die Geschiebebewegung, Mitteil, PVWES, Berlin, No. 26.
- Shen, H. W. (1981), "Sediment Transport", Chapter in Niobrara River Whooping Crane Habitat Study prepared by ERT, Inc., Fort Collins, Colorado.
- Shulits, S. (1935), "The Schoklitsch Bed-Load Formula," Engineering, London, England.
- Simons, D. B., and F. Senturk (1977) "Sediment Transport Technology," Water Resources Publication.
- Strand, R. I., and E. L. Pemberton (1982), "Reservoir Sedimentation," Technical Guideline for Bureau of Reclamation.
- Strickler (1923), Mitteilung No. 16 des Eidg. Amtes fur Wasserwirtschaft, "Beitrage zur Frage der Geschwindig eits formel."
- Wolman, M. G. (1954), "A method of Sampling Coarse River Bed Material," Transactions, AGU, vol. 35.
- Veronese, A. (1937), "Erosioni Di Fondo A Valle Di Uno Searico."
- Zimmerman and Maniak (1967), "Scour Studies," Journal of Hydraulics Division, ASCE.
- Yang, C. T. (1973), "Incipient Motion and Sediment Transport," Journal of the Hydraulics Division, ASCE, vol. 99, No. HY10, Proceeding Paper 10067.

Mission of the Bureau of Reclamation

The Bureau of Reclamation of the U.S. Department of the Interior is responsible for the development and conservation of the Nation's water resources in the Western United States.

The Bureau's original purpose "to provide for the reclamation of arid and semiarid lands in the West" today covers a wide range of interrelated functions. These include providing municipal and industrial water supplies; hydroelectric power generation; irrigation water for agriculture; water quality improvement; flood control; river navigation; river regulation and control; fish and wildlife enhancement; outdoor recreation; and research on water-related design, construction, materials, atmospheric management, and wind and solar power.

Bureau programs most frequently are the result of close cooperation with the U.S. Congress, other Federal agencies, States, local governments, academic institutions, water-user organizations, and other concerned groups.

A free pamphlet is available from the Bureau entitled "Publications for Sale." It describes some of the technical publications currently available, their cost, and how to order them. The pamphlet can be obtained upon request from the Bureau of Reclamation, Attn D-922, P O Box 25007, Denver Federal Center, Denver CO 80225-0007.

