

# RECLAMATION

*Managing Water in the West*

Hydraulic Laboratory Technical Memorandum PAP-1067

## Rock Slough Fish Screen Hydraulic Evaluation

Contra Costa Water District



U.S. Department of the Interior  
Bureau of Reclamation  
Technical Service Center  
Hydraulic Investigations and Laboratory Services Group  
Denver, Colorado

September 2012

# Rock Slough Fish Screen Hydraulic Evaluation

Joshua D. Mortensen and Tracy B. Vermeyen P.E.  
Prepared: Joshua D. Mortensen and Tracy B. Vermeyen, P.E.  
Hydraulic Engineer, Hydraulic Investigations and Laboratory Services Group, 86-68460

Tommy L. Wahl Acting  
Technical Approval: Robert F. Einhellig, P.E.  
Manager, Hydraulic Investigations and Laboratory Services Group, 86-68460

Connie Svoboda 5/31/2012  
Peer Review: Connie D. Svoboda, P.E. Date  
Hydraulic Engineer, Hydraulic Investigations and Laboratory Services Group, 86-68460

# Introduction

The Rock Slough Fish Screen was recently constructed on the Rock Slough Intake upstream from a pumped diversion in the Contra Costa Canal. The fish screen structure was designed to minimize the entrainment of fish associated with the diversion of water at the Rock Slough Intake. The screen should also reduce potential predation on target species in the Contra Costa Canal. The objective of this project was to assess the hydraulic performance of the Rock Slough Fish Screen structure by measuring approach velocities near the screens to determine if the structure is operating within the established criteria for target fish species in the Sacramento - San Joaquin Delta.

## Background

The Contra Costa Canal was completed by the U.S. Department of the Interior, Bureau of Reclamation, Mid-Pacific Region (Reclamation) in 1948. The canal, which is owned by Reclamation and operated by the Contra Costa Water District (CCWD), is the primary conveyance facility for CCWD's untreated water supply. It carries water from CCWD water supply intakes for deliveries to treatment plants, large industries, and irrigation customers throughout CCWD's service area. The canal is 48 miles long with capacities ranging from 350 ft<sup>3</sup>/sec at Pumping Plant 1 to 22 ft<sup>3</sup>/sec at its western terminus at Martinez Reservoir. The easternmost section of the canal is hydraulically connected to Rock Slough, and is tidal; this section is approximately 4 miles in length, and is located between the new Rock Slough Fish Screen and Pumping Plant 1. Water from the Sacramento-San Joaquin Delta is diverted at Rock Slough to supply the Contra Costa Canal (Figure 1). Until recently, the canal diversion at Rock Slough was one of the largest unscreened diversions in the Delta.

Construction of the fish screen at Rock Slough is required in the Los Vaqueros Biological Opinion for Delta Smelt issued by the US Fish and Wildlife Service in 1993 (U.S. Fish and Wildlife Service, 1993) and by Section 3406(b) of the Central Valley Project Improvement Act (CVPIA). Several resident and migratory fish species, including the endangered winter-run Chinook salmon and the threatened Delta smelt, can be entrained into the Contra Costa Canal. Other species affected by the project include: steelhead, green and white sturgeon, longfin smelt, split-tail, Sacramento blackfish, hitch, hardhead, and tule perch.

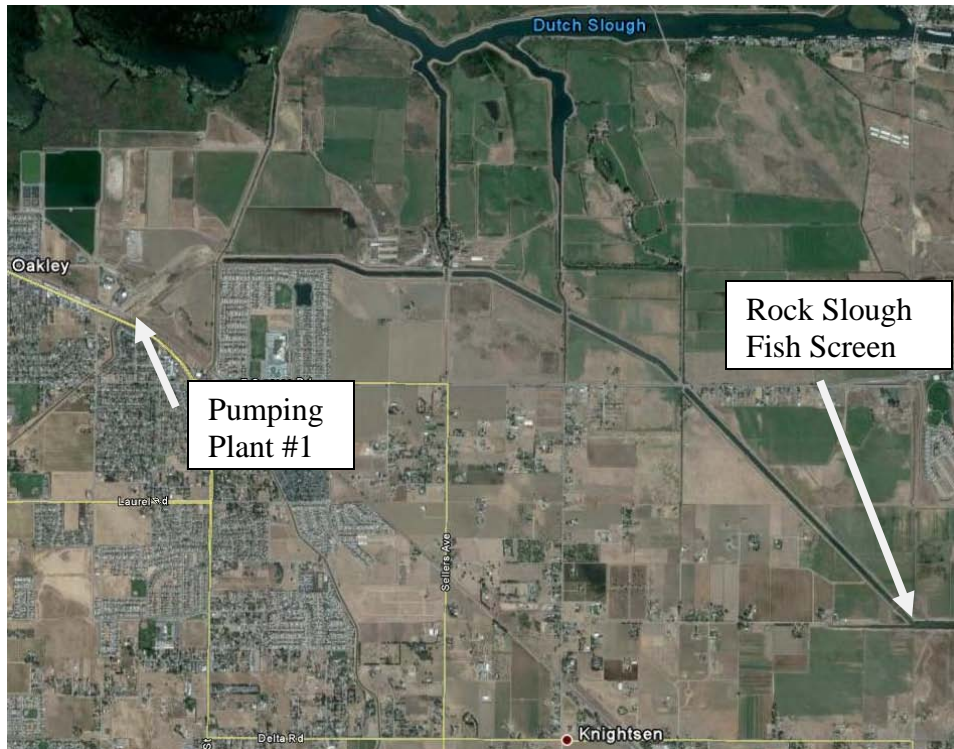

**Figure 1.** Location of Rock Slough Fish Screen and Pumping Plant No. 1 along Contra Costa Canal.

A Final Environmental Assessment and Finding of No Significant Impact for construction of the Rock Slough Fish Screen were published in 1997. Fish screen design began in 1997 and was completed in 1998. The original solicitation was issued and canceled in 1999 due to lack of right-of-way. Phase 1 of the project was constructed in 2001 which included widened areas of an access road along the Contra Costa Canal. Phase 2 of the project was constructed in 2009 and included dewatering the channel using setback levees and cofferdams to prepare for construction of the screen structure in the channel bed. Temporary bypass pumping was installed in 2010 to supply water to the Contra Costa Canal during construction of the screen structure. Phase 3 which included solicitation, contract award and fish screen construction was awarded in May 2010. As of spring 2012, the facility is in final testing. The completion of Rock Slough Fish Screen construction is expected in 2012.

## Rock Slough Fish Screen Description

The Rock Slough Fish Screen is located about 4 miles upstream from Pumping Plant No. 1 on the Contra Costa Canal. The fish screen consists of a cast-in-place reinforced concrete footing, pier, and abutment structure. The structure is founded on pre-cast/pre-stressed concrete pile foundation system and has steel sheet pile cutoffs and tied sheet pile abutment walls. The structure contains 8 structural bays with 4 fish screen panels per bay. Bays are numbered from upstream to downstream and referred to as B1 through B8 in this report, as shown in Figure 2.

The fish screens are made of stainless steel profile wire mesh. Above each screen is a stainless steel barrier panel.

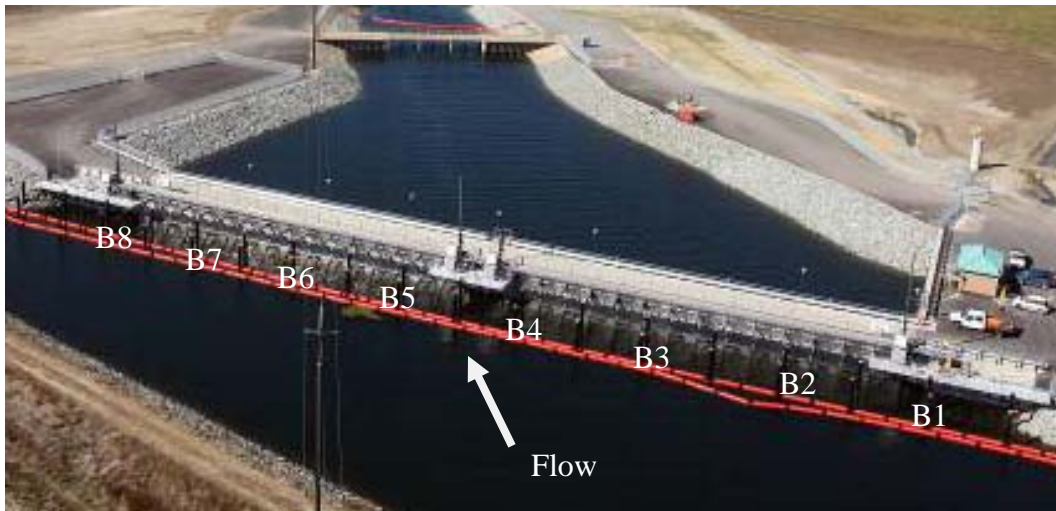

**Figure 2.** Rock Slough Fish Screen structure with Rock Slough in foreground and Contra Costa Canal in background (at top of photo). Screen bay reference numbers are shown.

The Rock Slough Fish Screen structure was sized for maximum diversion in Contra Costa Canal plus tidal inflows, which resulted in overall structure length of 320 ft (293 ft effective length.) The screen panels have an effective width of approximately 9.5 ft, and are 14 ft in height. Figure 3 shows fish screen structure, trash rack superstructure, and concrete footing. The fish screens are inclined  $5^{\circ}$  from vertical. The fish screen design specifies a 1.75 mm maximum slot opening and at least 40 percent open area (porosity). One bay near the middle of the structure (B4), is equipped with a solid stainless steel panel that is automatically opened for pressure relief if the head differential across the screen structure exceeds a threshold of about 18 to 21 inches. Adjustable steel baffles (with 6 adjustable vanes per screen panel) are located downstream of each panel to create uniform approach velocities along the entire screen length.

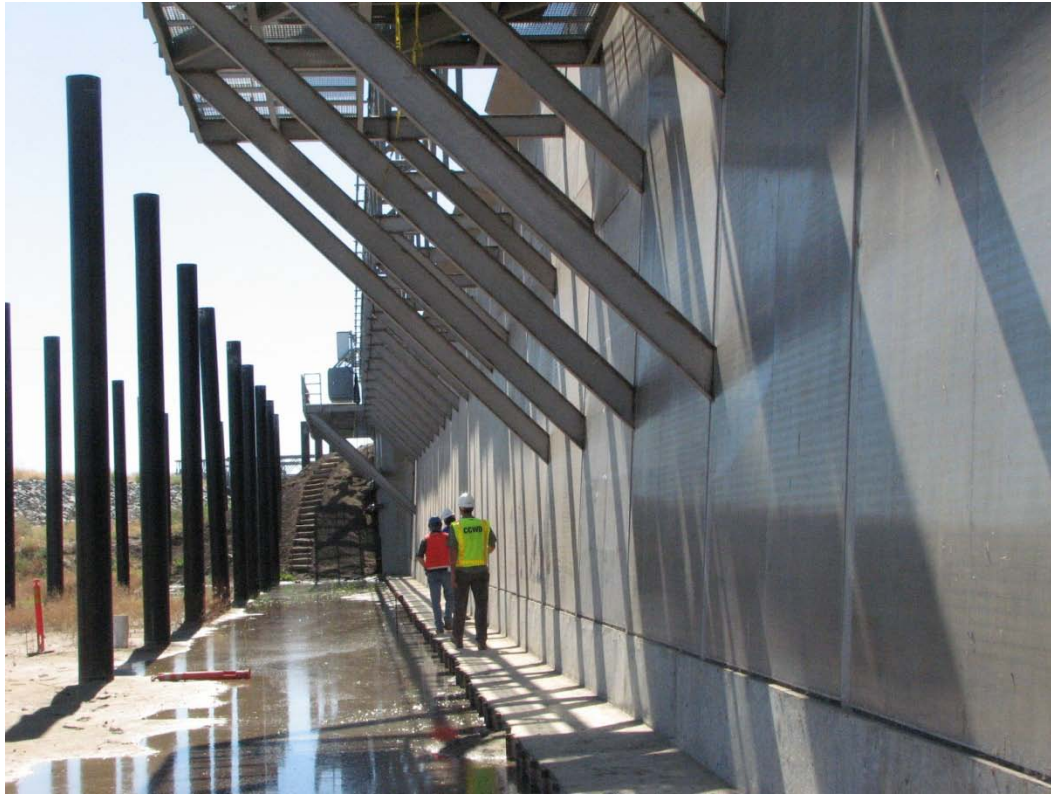

**Figure 3.** Rock Slough side of fish screen structure while dewatered for construction. Log boom piles, fish screen panels, concrete footing and supports for debris conveyance system are visible.

The screen is equipped with four automated hydraulic trash rakes and a debris conveyance system to keep the fish screens clean (Figure 4). The rakes are capable of cleaning the fish screens continuously or intermittently. Four rakes are included in the design to clean 31 screen panels. If the debris load warrants, two additional rakes can be added. One complete cleaning cycle time using the four rakes will not exceed 32 minutes (rake supplier estimates 16.5 minutes cleaning cycle time).

## Hydraulics

Water in Rock Slough and the eastern portion of the Contra Costa Canal is hydraulically connected to the Delta, and is tidal. Tidal fluctuation of water level at the site causes flow into the Rock Slough Fish Screen as the Contra Costa Canal fills on incoming (flood) tide, and causes flow through the screen in the reverse direction, from the Canal into Rock Slough, as the Canal drains tidally on the outgoing (ebb) tide. Typical tidal change in water surface elevation at the site is from 1 to 4 feet. Design high water surface elevation is +8.0 ft and the design low water surface elevation is -1.6 ft (in reference to the National Geodetic Vertical Datum of 1929, or NGVD29). Design water surface elevation ranges were calculated using the Old River at Byron gage which is maintained by the California Department of Water Resources.

There is also a water level gage at Rock Slough above the Contra Costa Canal which is managed by California Department of Water Resources.

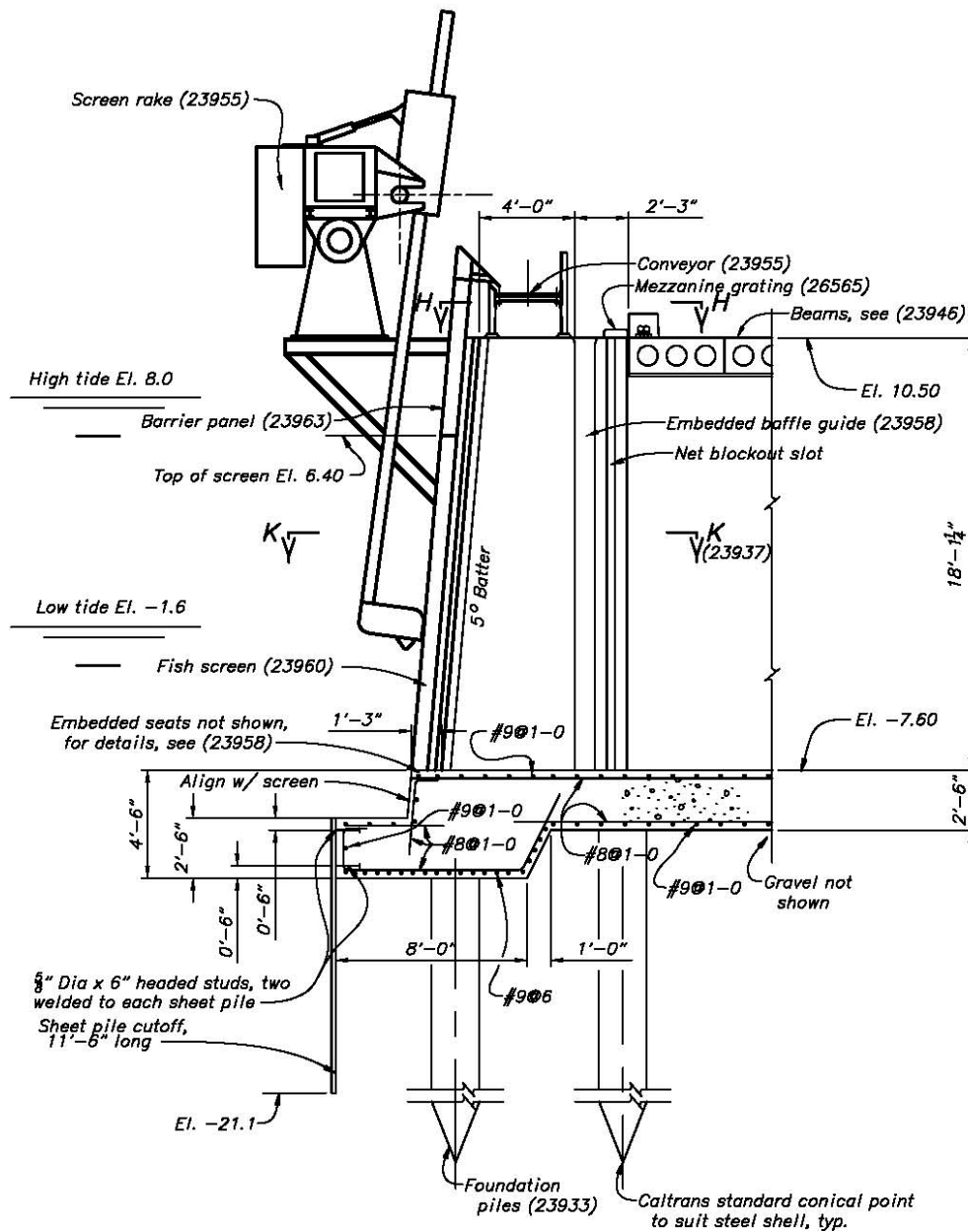

**Figure 4.** Section view of the trash rake cleaning system.

A 1999 physical model study performed in Reclamation’s hydraulics laboratory in Denver concluded that it should be possible to set the adjustable baffles to achieve uniform approach velocities at the location which has minimal sweeping flows (Hanna and Mefford, 1999).

## Fish Screening Criteria

Positive barrier fish screens are typically designed to meet velocity criteria for the protection of threatened and endangered fish species. The primary criteria are the sweeping and approach velocities at the screen face. Sweeping velocity is defined as the component parallel to the screen face and approach velocity is the component perpendicular (normal) to the screen face (DeMoyer and Vermeyen, 2009). At the Rock Slough site, the typical riverine sweeping velocity criteria cannot be met because the site is tidal and has periods of no flow or flow in either the upstream or downstream direction.

The approach velocity criteria for the Rock Slough Fish Screen are primarily for the protection of winter run Chinook salmon (*Onchorhynchus tshawytscha*) and Delta smelt (*Hypomesus transpacificus*). The National Marine Fisheries Service (NMFS) has established fish screen criteria for juvenile anadromous salmonids to be less than 0.33 ft/sec (National Marine Fisheries Service, 1997). In addition to the NMFS criteria, the U.S. Fish and Wildlife Service (USFWS) published a Biological Opinion for the Los Vaqueros Project that requires the Rock Slough Fish Screen to maintain an average approach velocity of 0.2 ft/sec or lower (U.S. Fish and Wildlife Service, 1993). The NMFS and USFWS criteria establish a maximum allowable and average approach velocity for this fish screen evaluation, respectively.

## Data Collection and Analyses

### Velocity Measurements

A major component of the hydraulic evaluation was velocity measurements over the majority of the fish screens. Three-dimensional velocity measurements were taken approximately 3 inches from the screen face using Acoustic Doppler Velocimeters (ADV) as shown in Figure 5. The 10 MHz ADVs have an accuracy of  $\pm 1\%$  of the measured velocity with a velocity range from  $\pm 0.003$  to 8.2 ft/s. Data were acquired at sampling rates of 25 Hz, allowing for the measurement of turbulence characteristics of the flow.

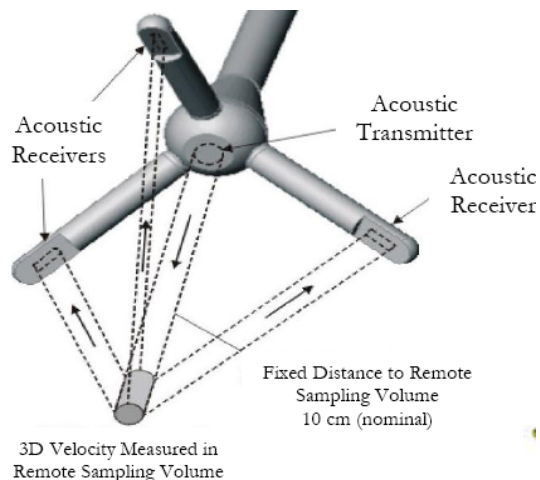



Figure 5 SonTek/YSI Field ADV probe and splash-proof signal processing module.

### ADV Theory of Operation

An ADV is a high-resolution acoustic Doppler velocimeter that measures 3-dimensional velocity vectors in a remotely sampled volume. The ADV is a bi-static Doppler current meter which means the ADV uses separate acoustic transducers for transmitter and receivers (Figure 6). The transducers are mounted such that their respective beams intersect over a volume of water located some distance away, called the sampling volume. ADVs normally report velocity data in a Cartesian (X,Y,Z) coordinate system relative to the probe's orientation. Depending on the ADV model, the sampling volume can be located either 5 or 10 cm from the tip of the acoustic sensor. The 5 cm sensor is usually used in laboratories and in shallow water, and the 10 cm sensor is a more robust field probe that has less potential for flow interference in turbulent flow. The field probes were used for this project (serial numbers A254A, A693, and 1328). The probe configuration used throughout testing is shown in Table 1.



**Figure 6.** Schematic of ADV probe head orientation and sampling volume. (Image provided by Sontek/YSI Inc.).

**Table 1.** Sontek ADV Instrument Specifications and Configuration

Parameter	Value
Instrument Model	Field ADV
Instrument Serial Numbers	A254, A693, and 1328
Operating Acoustic Frequency	10 Megahertz (MHz)
Sampling Volume	0.25 cm <sup>3</sup> (0.015 in <sup>3</sup> )
Distance to Sampling Volume (from acoustic transmitter)	10 cm (3.94 inches)
Resolution	0.01 cm/sec (0.0003 ft/sec)
Accuracy	±1 % of measured velocity
Instrument Configuration	
Sampling rate	25 Hz
Max Velocity Range Setting	30 cm/s (0.98 ft/s)
Data Collection Period (Burst)	24 seconds
Salinity	1 ppt (part per thousand)
Water temperature	21° C

### ADV Mounting Configuration

Velocimeters were clamped onto the trash rack head as shown in Figure 7. The ADVs were positioned so that velocities were measured approximately 3 inches from the screen face with the x-velocity component perpendicular and y-velocity component parallel to the screen face. Three ADVs were used in testing and either one or two probes were used on one trash rake head. For the one probe configuration, the instrument was mounted about 1.7 ft from the left side of the rake head to be upstream from the trash rake mast. For two probes, each ADV was mounted about 1 ft in from both sides of the rake head (Figure 7). The probes were mounted facing upward to reduce flow disturbance and minimize the risk of contact with the channel floor. The ADV probes were located 31 inches above the rake head brush. This position placed the ADV sample volume 35 inches above the rake head brush. Mounting the instruments on the trash rack allowed them to be moved quickly and accurately in both vertical and horizontal directions to specific measurement locations on the screen.

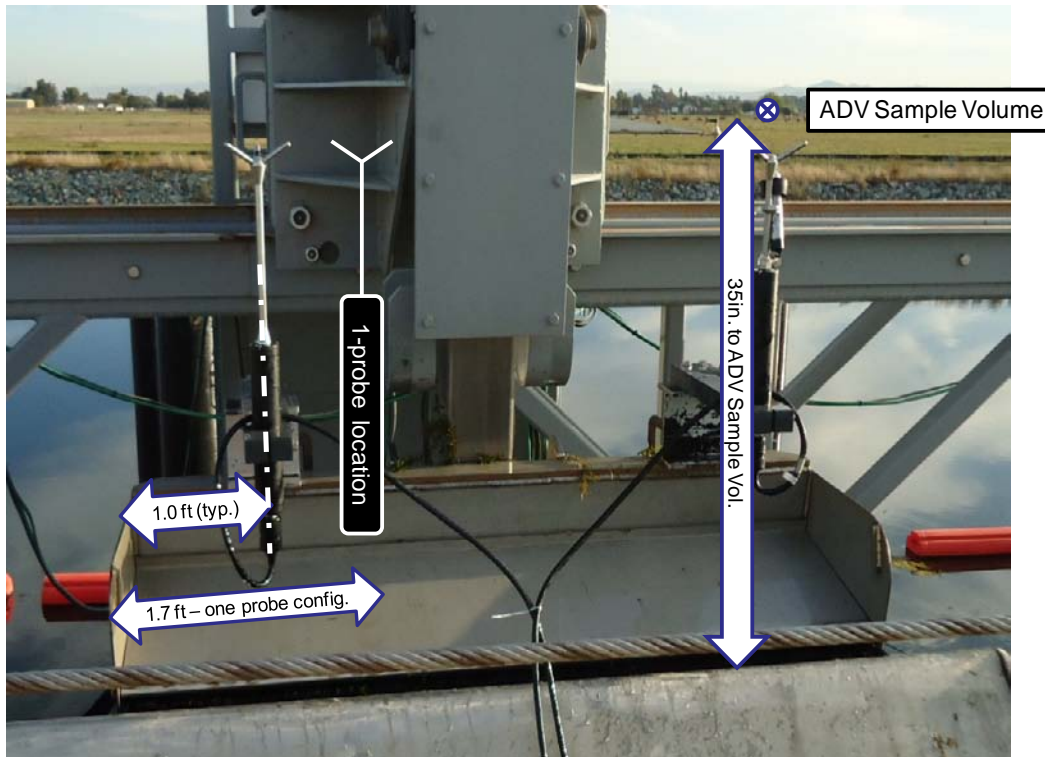

**Figure 7.** Two ADV probe configuration mounted on trash rake head and the approximately location of the 1 probe configuration.

## Velocity Measurement Locations

### **1- Probe Configuration**

Six measurements were made for each screen panel using the 1-probe configuration. During data collection the rake head made vertical passes at two horizontal locations on each panel and measurements were made at 3 vertical positions on each pass. The first and second horizontal measurement location was about 2.2 and 6.2 ft from the upstream end of the panel, respectively (Table 2). On test day 1, vertical positions were set to elevations -4.17 ft, -0.67 ft, and 2.8 ft. However, the 2.8 ft elevation was out of the water for the entire testing period. Adjustments were made on days 2 and 3 to position the ADVs at elevations -4.17, -1.67, and -0.47 ft.

### **2-Probe Configuration**

Twelve measurements were made for each screen panel using the 2-probe configuration. The horizontal locations for vertical passes with the rake head were the same as the 1 probe configuration. Measurement locations for the probes are shown in Table 2. The distance and location are referenced from the upstream end of the screen panel. The two probes are referred to as the upstream (U/S) or downstream (D/S) probe as shown in the table. The vertical positions were the same as the 1-probe configuration.

**Table 2.** Distances for horizontal probe and location references on each screen.

Probe Configuration	Probe	Location	Distance from U/S end of panel (ft)
2	U/S	L1	1.5
	D/S	L2	4.5
	U/S	L3	5.5
	D/S	L4	8.5
1	-	L5	2.2
	-	L6	6.2

## Water Level

Water surface elevations were monitored during testing with water level data available online at the California Data Exchange Center (CDEC) website. CDEC stage elevations at the Rock Slough are reported with respect to the NAVD88 vertical datum. Stage data were converted to the project construction datum (NGVD 29) for the Rock Slough Fish Screen by subtracting 2.55 ft from the stage data, which is the site-specific correction from NAVD88 to NGVD29. Stage data were used before testing to plan when to start and end testing each day to ensure that the low tide and incoming flood tide conditions were captured in the testing. Low tide conditions are when the smallest amount of screen face is submerged, so flow into the screen is concentrated in a portion of the entire screen. These conditions were included in the hydraulic analysis to test whether flow into the screen through the reduced screen area exceeds the approach velocity criteria. Flood tide conditions are when the maximum tidal flow occurs through the screen. These conditions were included to test whether pumped diversions plus tidal flow through the screen would exceed approach velocity criteria. Stage records were used during post-processing and analyzing hydraulic performance.

Two HOBOTM submersible water level loggers (see table 4 for manufacturer’s specifications) were located at the pressure relief bay for measuring head differential across the screen structure. One logger was placed upstream and one logger downstream of the screen at the same distance from the top of the screens to log water depths. A third transducer was mounted to one of the ADV probes during testing to help monitor depth at the time of each velocity measurement. A barometric pressure logger was also deployed to collect atmospheric pressure data necessary to convert absolute pressure measurements to water depths.

**Table 3.** HOBOTM Water Level Logger performance specifications (photograph was taken from ONSET’s online product brochure).

Parameter	Specification
Pressure Range	0 to 30 ft
Water level accuracy	Typical error - $\pm 0.05\%$ FS, 0.015 ft of water

Parameter	Specification
	Maximum error - $\pm 0.1\%$ FS, 0.03 ft of water
Resolution	< 0.003 psi, 0.007 ft of water
Pressure response time	90% < 1 second

## Data Collection Period

The fish screen structure was tested for 3 consecutive days (October 11, 12, and 13) referred to as Day 1, Day 2, and Day 3, respectively. Approach velocity measurements were collected at low tide and through the rising flood tide with concurrent pumping at Pumping Plant No. 1. This test methodology was designed to capture the conditions in which the highest approach velocities are likely to occur. Pumping Plant No. 1 maintained a diversion rate of about 200 ft<sup>3</sup>/sec through the screens during testing, as summarized in Table 4.

**Table 4.** Pumping operations and screen head differential data for testing periods for each test day.

Day	Pump Schedule PST		Average Pump Discharge (ft <sup>3</sup> /s)	Max head differential across fish structure (ft)
1	Start	11:30	204.5	0.197
	Stop	16:05		
2	Start	12:30	204.7	0.081
	Stop	17:45		
3	Start	12:15	203.0	0.197
	Stop	18:30		

## Screen Cleaning

To control debris accumulation on the fish screens, two trash rakes without probes were to be operated during testing. Unfortunately on Day 1 of testing, trash rake #2 was inoperable and parked mid-way across bay 3. This and other trash rake issues led to excessive debris accumulation during Day 1 testing. Although the full screen structure was cleaned as much as possible prior to and during testing, debris on the screen caused high velocities at some locations on the screens. Repairs to trash rake #2 were completed on Day 2 and the rake was parked at the

end of bay 4. Debris was particularly problematic during later portions of the testing period on Day 2 when tidal flows were higher and the time since the last cleaning was greatest. Despite issues keeping the screen clean, the head differential across the screen never exceeded 0.2 feet (Table 4).

Debris-affected velocity data from Day 1 and Day 2 were discarded from the final analysis.

## **Data Analyses**

Velocity data were analyzed using WinADV which is a Windows-based viewing and post-processing utility for ADV files that was developed by Reclamation (Wahl, 2000). This program provides an integrated environment for viewing, reviewing, and processing data collected using SonTek and Nortek acoustic Doppler velocimeters (ADV's). Time series velocity data were processed to determine the average velocity components (x,y,z) and summary statistics for each measurement location. Data were filtered to remove measurements with signal-to-noise ratios (SNR) less than 5 and correlation (COR) values less than 70. The filtered data were carefully analyzed to remove debris-affected velocity measurements through the fish screen then compiled to assess the performance of each bay and screen panel.

## **Results and Discussion**

### **Day 1 Test Results (Oct. 11, 2011)**

Velocity testing for Day 1 was conducted from 11:45 to 16:00 PST during low tide and incoming flood tide. Figure 8 shows velocity data taken for each bay and the water surface elevation at the screens throughout the testing period. Testing began with the 2-probe configuration on screen bay B1. Much of the data taken before 12:00 was discarded because of outward flow through the screen caused by an outgoing tide. These velocity measurements were repeated beginning around 13:30 as the incoming tide and pumping at Pumping Plant No. 1 generated flow through the screen into the Contra Costa Canal. Only a few measurements were made at screen bay B3 and none at B4 because access was blocked by a trash rake stuck in front of the second screen of B3.

At 13:30, velocity measurements with the 1-probe configuration were started at B8. Velocities were collected working upstream toward the middle of the structure (B5). Since the screens were not being cleaned during testing, debris was visually apparent on most of the screen panels and weeds periodically fouled the ADV probes. The increasing velocity trend in figure 8 was likely attributed to progressive debris accumulation on the screens. As a result, all velocity measurements made after 15:30 were excluded from the overall analysis of screen performance.

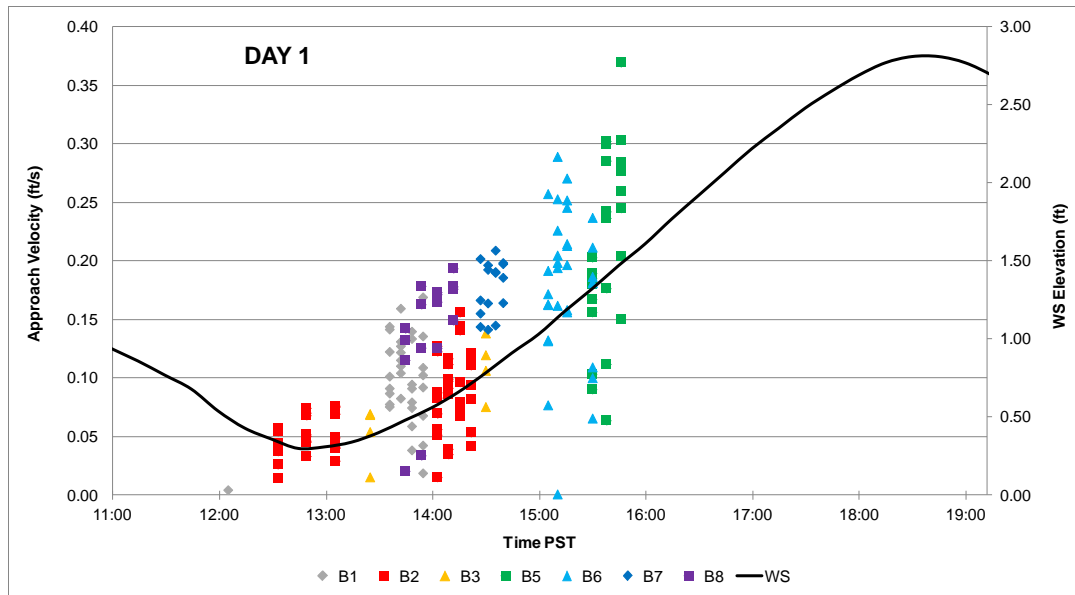
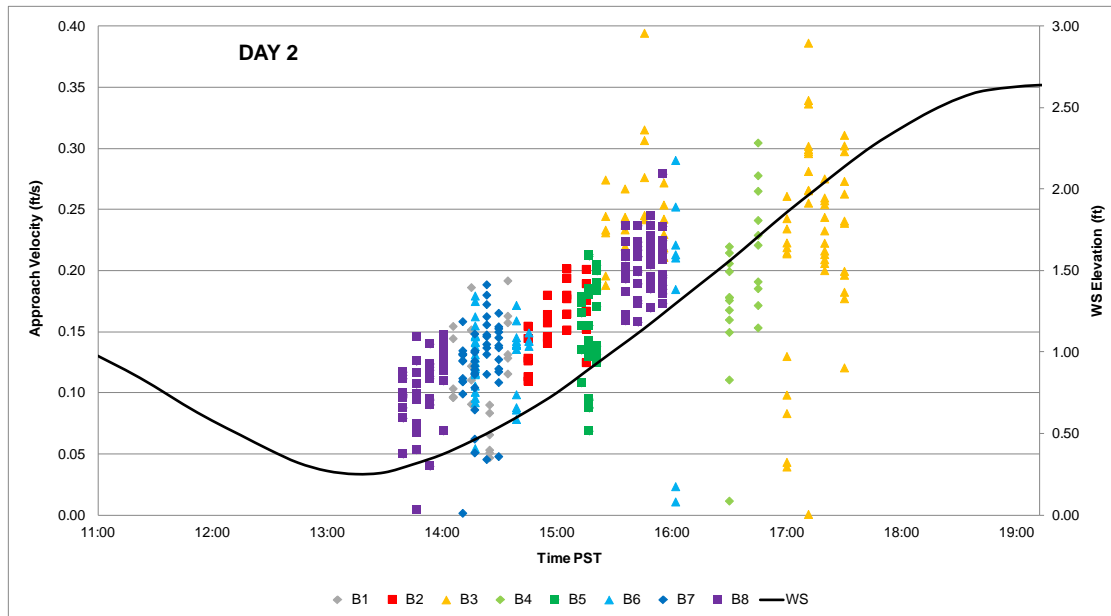

**Figure 8.** Approach velocity and water surface elevation data from Day 1 (October 11, 2011).

## Day 2 Test Results (Oct. 12, 2011)

Day 2 testing was started at 13:40 to avoid outward flows at the screen face that were observed at the end of the ebb tide on Day 1. The 2 probe configuration was used on the downstream half of the structure, beginning at B8 and moving toward the B5. At 14:00, measurement collection using the 1 probe configuration began at B1 and also moved toward the middle of the structure. The trash rake blocking bays 3 and 4 on the first day was moved to the center of the structure, but was still unable to actively clean. This allowed every screen panel of the structure to be measured except for the center most panels on bays 4 and 5 where the inactive trash rakes were parked.

As seen in Day 1, the velocities increased with time throughout the test period (Figure 9). The trend of increasing velocities from 13:40 until about 15:30 was likely due to the increasing flow through the screen from the flood (incoming) tide. Pumping Plant No. 1 flows were held constant through testing. Until about 15:30, minimal debris was observed on the screen. Despite an increased effort to keep the screens clean, debris again became an issue later in the testing period. This was evidenced by a sharp increase in velocities and debris apparent on much of the screen. Again, measurements made after 15:30 were assumed to be biased by the debris-laden screen and were not used in the overall analysis.



**Figure 9.** Approach velocity and water surface elevation data from Day 2 (October 12, 2011).

### Day 3 Test Results (Oct. 13, 2011)

Testing on Day 3 began at 15:00 and ended at 18:00. Velocity data were collected during the highest flows with the incoming time. Cleaning the screens before and during testing was prioritized on Day 3, including manual operation of the rake mechanisms that had not functioned in automatic mode on Days 1 and 2. The entire structure was cleaned immediately before data collection and the downstream half of the structure (B5-B8) continued to be cleaned during testing of bays B1 through B4

Only the 2-probe configuration was used on Day 3. B7 was tested first to confirm results from Days 1 and 2. After B7 velocities were measured, the ADVs were moved to B4 and data were collected upstream to B1. The trash rake servicing bays 5-8 was restarted in automatic mode. This approach was taken because some of the upstream bays had not yet been measured during the highest flow with clean screens. Debris on the screens was not visually apparent until about 18:00 near the end of the test period. As a result, approach velocity data from Day 3 are much more uniform than the previous two days as shown in figure 10.



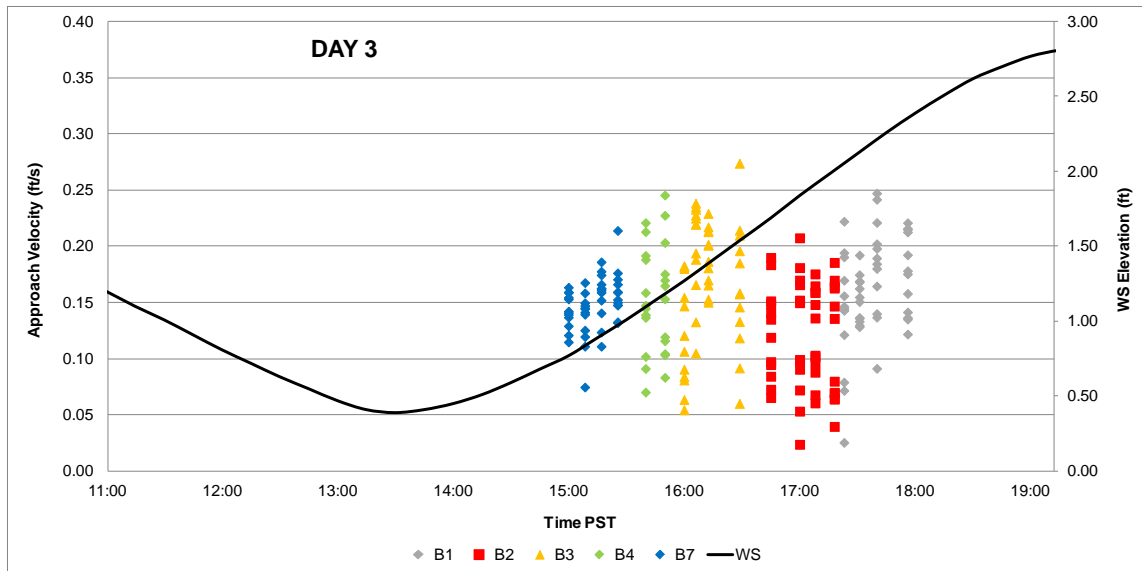

**Figure 10.** Approach velocity and water surface elevation data from Day 3 (October 13, 2011).

## Summary of Results

Throughout the three days of testing a total of 804 velocity measurements were collected. Of that total, there were 589 that were considered valid and used in the overall screen performance analysis. Measurements taken during periods of ebbing or outgoing tide (which causes outward flow through the screen) or on screens with accumulated debris were not used for the screen performance analysis. Table 5 summarizes the approach velocities through each screen bay and the entire structure. The percentage of high velocities include any velocity that was greater than 0.2 ft/sec. These results indicate that velocities through the screens were uniform across the entire structure and that overall the screen meets the established velocity criteria.

Velocity data collected on Day 2 and Day 3 were combined to create a data set when all screen bays were relatively clean. These data were used to create a contour plot of the approach velocity distribution as shown in figure 11. The velocity distribution was relatively uniform with isolated instances of high velocities (i.e. greater than 0.2 ft/sec). Areas with orange and red fill are those where velocities were higher than velocity criteria. Area colored blue and green are less than 0.2 ft/sec.

**Table 5.** Summary of approach velocity ( $V_x$ ) measurements at low tide and incoming tide through each Rock Slough Fish Screen bay.

Approach Velocity Data (ft/sec)									
	B1	B2	B3	B4	B5	B6	B7	B8	OVER-ALL
<b>MAX</b>	0.25	0.21	0.27	0.25	0.21	0.29	0.21	0.19	0.29
<b>AVG</b>	0.13	0.11	0.16	0.15	0.15	0.15	0.14	0.11	0.14
<b>HIGH</b>	8.7%	2.3%	28.6%	20.8%	10.0%	16.7%	2.7%	0.0%	8.7%

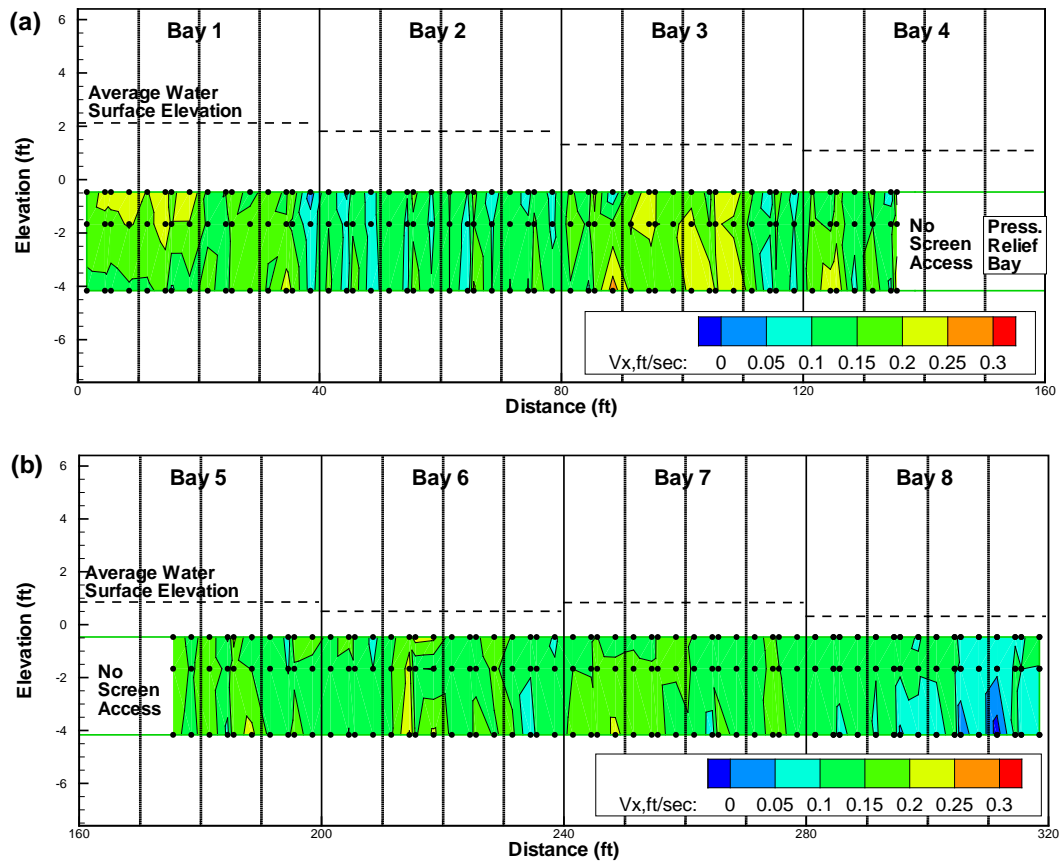

**Figure 11.** Plot of approach velocity ( $V_x$ ) contours using clean screen data. Panel (a) contains approach velocity contours for Bay 1-4 and panel (b) has contours for bays 5-8. Dashed lines represent the average water surface elevation during data collection and black dots are data points.

## Conclusions and Recommendations

The fish screen structure at the Rock Slough Intake was evaluated for hydraulic performance the week of October 10, 2011. Approach velocities measured 3 inches from the screen face indicated that the facility is capable of operating within hydraulic criteria for Delta smelt (velocity less than 0.2 ft/sec) for a range of hydraulic conditions that are influenced by both tidal flows and pumping rates (up to 200 ft<sup>3</sup>/sec) at Pumping Plant No. 1. Uniform velocity distribution across the fish screen confirmed that the baffles were adequately positioned and do not need further adjustment.

Debris on the fish screens, mostly aquatic vegetation, was the primary issue during testing, and poses the greatest threat to future hydraulic performance. Debris was shown to have a significant impact on screen performance if the screens are not regularly cleaned. Due to the potential for heavy debris loads, it is recommended that the fish screen cleaning system be regularly evaluated for debris removal performance.

Debris removal evaluation may be more effective at assessing the structure's hydraulic operation than periodic evaluations using approach velocity measurements.

## References

California Department of Water Resources. (n.d.). *Rock Slough ABV Contra Costa Canal, Station ID=RSL*. Retrieved October 2011, from California Data Exchange Center: [http://cdec.water.ca.gov/cgi-progs/stationInfo?station\\_id=RSL](http://cdec.water.ca.gov/cgi-progs/stationInfo?station_id=RSL)

DeMoyer, C., Vermeyen, T., *Guidelines for Performing Hydraulic Field Evaluations at Fish Screening Facilities*, Water Resources Technical Publication, U.S. Department of the Interior, Bureau of Reclamation, Denver, Colorado, April 2009, [http://www.usbr.gov/pmts/hydraulics\\_lab/pubs/manuals/Guidelines%20for%20Fish%20Screening%20Evaluations.pdf](http://www.usbr.gov/pmts/hydraulics_lab/pubs/manuals/Guidelines%20for%20Fish%20Screening%20Evaluations.pdf)

Hanna, L. J., & Mefford, B. W. (1999). *Hydraulic Model Study of Contra Costa Fish Screen Structure and Trash Rake*. Denver: Bureau of Reclamation.

National Marine Fisheries Service. (1997). *Fish Screening Criteria for Anadromous Salmonids*. Santa Rosa: NOAA.

U.S. Fish and Wildlife Service. (1993, September 9). [Memorandum to regional director, U.S. Bureau of Reclamation, Sacramento, California, on formal consultation on effects of the proposed Los Vaqueros Reservoir Project on delta smelt, Contra Costa County, California.]. Sacramento, CA.

Wahl, T. (2000). Analyzing ADV Data using WinADV. *Joint Conference on Water Resources Engineering and Water Resources Planning & Management*. Minneapolis.