

RECLAMATION MANUAL RELEASE

Comments on this draft release must be submitted to dmarsh@usbr.gov by 05/10/2024.

Background and Purpose of the Following Draft Facilities Instructions Standards and Techniques (FIST) Manual

The Bureau of Reclamation has a new release Reclamation Manual FIST 2-12, Mechanical Maintenance of Hydroelectric and Large Pump Units. Reclamation developed this release to ensure the most accurate information is available. This manual defines Reclamation practices for mechanical equipment maintenance requirements.

This manual is consolidating information on the maintenance of large pumps and hydroelectric units from FIST 4-1A, Maintenance Scheduling for Mechanical Equipment, into a dedicated document. This discusses required mechanical maintenance for turbines, generators, large pumps, and associated equipment.

The goal of preparing this external review is to provide stakeholders, industry, and other entities with the opportunity to comment on it in draft form. Comments will make the program more responsive to technologies, industry practices, industry standards and thus creating a more effective program for Reclamation and other users of this manual.

The Reclamation Manual is used to clarify program responsibility and authority and to document Reclamation-wide methods of doing business. All requirements in the Reclamation Manual are mandatory. FIST Manuals are written to be strictly followed but have provisions to deviate from the standards based on sound engineering logic. The process for deviating from FIST Manuals is outlined in Reclamation Manual Policy FAC P14, *Power Operations and Maintenance (PO&M) Technical Standards*.



— BUREAU OF —
RECLAMATION

Facilities Instructions, Standards, and Techniques - Volume 2–12

**Mechanical Maintenance of Hydroelectric
and Large Pump Units**



Mission Statements

The U.S. Department of the Interior protects and manages the Nation's natural resources and cultural heritage; provides scientific and other information about those resources; honors its trust responsibilities or special commitments to American Indians, Alaska Natives, Native Hawaiians, and affiliated Island Communities.

The mission of the Bureau of Reclamation is to manage, develop, and protect water and related resources in an environmentally and economically sound manner in the interest of the American public.

Disclaimer

This written material consists of general information for internal use only by Bureau of Reclamation operations and maintenance staff. Information contained in this document regarding commercial products or firms may not be used for advertising or promotional purposes and is not to be construed as an endorsement or depreciation of any product or firm by the Bureau of Reclamation.

Cover Photo – Inside the Roza Powerplant showing the generator with an American flag on the wall.
(By Dave Marsh)

REPORT DOCUMENTATION PAGE			<i>Form Approved OMB No. 0704-0188</i>		
Public reporting burden for this collection of information is estimated to average 1 hour per response, including the time for reviewing instructions, searching existing data sources, gathering and maintaining the data needed, and completing and reviewing this collection of information. Send comments regarding this burden estimate or any other aspect of this collection of information, including suggestions for reducing this burden to Department of Defense, Washington Headquarters Services, Directorate for Information Operations and Reports (0704-0188), 1215 Jefferson Davis Highway, Suite 1204, Arlington, VA 22202-4302. Respondents should be aware that notwithstanding any other provision of law, no person shall be subject to any penalty for failing to comply with a collection of information if it does not display a currently valid OMB control number. PLEASE DO NOT RETURN YOUR FORM TO THE ABOVE ADDRESS.					
T1. REPORT DATE (DD-MM-YYYY)T TBD		T2. REPORT TYPET Draft		T3. DATES COVERED (From - To)T Implementation Date: Upon publication.	
T4. TITLE AND SUBTITLE FIST Volume 2-12, Mechanical Maintenance for Hydroelectric and Large Pumping Units			5a. CONTRACT NUMBER		
			5b. GRANT NUMBER		
			5c. PROGRAM ELEMENT NUMBER		
6. AUTHOR(S) Power Resources Office Technical Services Center			5d. PROJECT NUMBER		
			5e. TASK NUMBER		
			5f. WORK UNIT NUMBER		
7. PERFORMING ORGANIZATION NAME(S) AND ADDRESS(ES) Power Resources Office, Bureau of Reclamation Denver Federal Center P.O. Box 25007 Denver CO 80225-0007			8. PERFORMING ORGANIZATION REPORT NUMBER FIST 2-12		
9. SPONSORING / MONITORING AGENCY NAME(S) AND ADDRESS(ES) Power Resources Office Bureau of Reclamation Mail Code 86-51000 PO Box 25007 Denver CO 80225-0007			10. SPONSOR/MONITOR'S ACRONYM(S) PRO		
			11. SPONSOR/MONITOR'S REPORT NUMBER(S)		
12. DISTRIBUTION / AVAILABILITY STATEMENT Available from the National Technical Information Service, Operations Division, 5285 Port Royal Road, Springfield, Virginia 22161					
13. SUPPLEMENTARY NOTES					
14. ABSTRACT The Bureau of Reclamation operates and maintains 53 hydroelectric powerplants and many switchyards, pumping plants, dams, canals, and associated facilities that are important to electric power and water delivery systems.					
15. SUBJECT TERMS					
16. SECURITY CLASSIFICATION OF:			17. LIMITATION OF ABSTRACT UL	18. NUMBER OF PAGES 119	19a. NAME OF RESPONSIBLE PERSONT Power Resources Office
a. REPORT UL	b. ABSTRACT UL	c. THIS PAGE UL			19b. TELEPHONE NUMBER (include area code) (303) 445-2922

Facilities Instructions, Standards, and Techniques - Volume 2-12

Mechanical Maintenance of Hydroelectric and Large Pump Units

Prepared by

**Power Resources Office
Technical Service Center
Denver, Colorado**

Acronyms and Abbreviations

ac	alternating current
ANSI	American National Standards Institute
ASME	American Society of Mechanical Engineers
dc	direct current
FIST	Facilities Instructions, Standards, and Techniques
Hz	hertz
O&M	operation and maintenance
PO&M	power operation and maintenance
PRO	Power Resources Office
psi	pounds per square inch
Reclamation	Bureau of Reclamation
rpm	rotations per minute
TGB	Turbine Guide Bearing
TSC	Technical Service Center

Symbols

%	percent
±	plus or minus
°	degree

Contents

Page

Acronyms and Abbreviations	ii
Symbols	ii
Codes and Standards	vi
Reclamation Standards and Documents	vi
Reclamation Forms	vi
References	vi
1.0 Introduction	1
1.1 Purpose and Scope	1
1.2 Reclamation Standard Practices.....	2
1.3 Maintenance Tables	2
1.4 Manufacturer Recommendations	2
1.5 FIST Revision Requests.....	3
1.6 Mechanical Database	3
2.0 Hydroelectric and Large Pump Unit Description and Maintenance	5
2.1 Hydraulic Turbines	5
2.1.1 Reaction Turbine (Rotating Energy Conversion)	5
2.1.2 Impulse Turbine (Kinetic Energy Conversion).....	8
2.2 Large Pumps (Water Conveyance Pumps)	9
2.2.1 Dynamic Pumps	9
2.3 Common Component Damage.....	10
2.4 Runners and Impellers	12
2.4.1 Maintenance of Runners and Impellers	13
2.5 Turbine Air Vent or Pressurized Air Injection Systems	14
2.5.1 Maintenance of Turbine Air Vents or Pressurized Air Injection Systems.....	15
2.6 Wearing Rings	15
2.6.1 Wearing Ring Maintenance	16
2.7 Pressure Boundary Components	16
2.7.1 Scroll Case and Draft Tube.....	17
2.7.2 Head Cover	18
2.7.3 Turbine Pressure Relief Valves	19
2.7.4 Fasteners (Critical Bolted Connections)	20
2.8 Wicket Gates	23
2.8.1 Wicket Gate Maintenance.....	25
2.9 Servomotors and Operating Linkages.....	27
2.9.1 Servomotor and Operating Linkage Maintenance	28
2.10 Shaft Seals.....	29
2.10.1 Packing or Stuffing Box.....	29
2.10.2 Mechanical Seals	30
2.10.3 Maintenance of Shaft Seals.....	31
2.11 Bearings	32
2.11.1 Fluid Film Bearings	32
2.11.2 Bearing Maintenance	37

2.12	Shaft and Shaft Couplings	39
2.12.1	Shaft and Shaft Coupling Maintenance	40
2.12.2	Shaft Alignment	41
2.13	Generator/Motor Mechanical Components.....	41
2.13.1	Air Coolers and Cooling Coils.....	41
2.13.2	Generator Brakes	43
2.13.3	Rotor	44
2.13.4	Turning of Rotor	45
2.13.5	Generator/Motor Mechanical Component Maintenance	49
2.14	Oil and Lubricants.....	50
2.15	Vibration Monitoring and Analysis	50
2.15.1	Proximity Probe Systems.....	51
2.15.2	Accelerometer Systems.....	51
2.15.3	Signature Analysis	52
2.15.4	Maintenance of Vibration Monitoring Systems.....	53

Figures

Figure	Page
1.—Francis Turbine.....	6
2.—Kaplan Turbine.....	7
3.—Impulse (Pelton) turbine	8
4.—Rotor turning gear mechanism.....	48
5.—Single spectrum plot.....	52

Photographs

Photograph	Page
1.—Turbine runner	6
2.—Cavitation damage on turbine runner.....	10
3.—Corrosion damage on wicket gates and stay vanes.....	11
4.—Head cover	19
5.—Wicket gates and stay vanes.	24
6.—Wicket gate shear pin.....	25
7.—Servomotor connecting rod.....	28
8.—Servomotor.....	28
9.—Spring loaded thrust shoe bearing.....	33
10.—Pivoted adjustable shoe thrust bearing.....	33
11.—Sleeve journal bearing.....	34
12.—Sleeve type guide bearing	35

13.—Adjustable segmented shoe bearing.....	35
14.—Shaft and coupling.	40
15.—Generator air cooler.	42
16.—Cooling coil for turbine bearing.....	43
17.—Brake shoe assembly.....	44
18.—Rotor assembly.....	45
19.—Rotor turning gear assembly.	48

Codes and Standards

None

Reclamation Standards and Documents

FAC 04-14, Power Facilities Technical Documents
FAC P14, Power Operations and Maintenance (PO&M) Technical Standards
FIST 2-1, Alignment of Rotating Machinery
FIST 2-2, Field Balancing Large Rotating Machinery
FIST 2-3, Mechanical Maintenance of Mechanical and Digital Governors for Hydroelectric Units
FIST 2-4, Lubrication of Powerplant Equipment
FIST 2-5, Turbine Repair
FIST 2-6, Maintenance of Auxiliary Mechanical Equipment
FIST 3-11, Generator Thrust Bearing Insulation and Oil Film Resistance
FIST 4-1A, Maintenance Scheduling for Mechanical Equipment
FIST 4-1B, Maintenance Scheduling for Electrical Equipment

Reclamation Forms

POM: <https://teamssp.bor.doi.net/printanddup/forms/POM%20Forms/Forms/AllItems.aspx>
POM 160, Runner Inspection Report (Long Bucket - Clockwise Notation)
POM 161, Runner Inspection Report (Long Bucket - Counterclockwise Notation)
POM 162, Runner Inspection Report (Short Bucket - Clockwise Notation)
POM 163, Runner Inspection Report (Short Bucket - Counterclockwise Notation)
POM-226, FIST Revision Request

References

Fuller, Dudley D. Theory and Practice of Lubrication for Engineers, Wiley, 1984.

Pacific Gas and Electric Company. Proactive Repair of the Helms Pumped-Storage Plant.
HydroReview, Issue 9, Vol 32, July 2013.
<https://www.hydroreview.com/2013/11/07/proactive-repair-of-the-helms-pumped-storage-plant/>

1.0 Introduction

The Bureau of Reclamation (Reclamation) operates and maintains hydroelectric powerplants, switchyards, pumping plants, water delivery equipment, and associated facilities in the 17 Western United States. These facilities are critical to the electric power and water delivery systems relied on by many. These facilities house complex electrical and mechanical equipment that must be kept operational. These instructions provide criteria and procedures that should be utilized by the various offices involved in managing Reclamation facilities and assets.

This document establishes standard technical practices to ensure the safe, reliable, economical, and efficient operations and maintenance of Federal facilities by keeping related assets in good condition and ultimately protecting the Federal investment. These technical practices provide a sufficient level of detail to ensure consistent application while providing flexibility for the use of innovative techniques and approaches. These instructions are developed to be utilized by transferred facilities and other entities as appropriate. These instructions are intended to promote uniformity in the manner that assets are managed, documented, and coordinated. This document was developed with input from staff in Reclamation's Denver, regional, and area offices.

1.1 Purpose and Scope

This document is intended to promote uniformity in the manner that assets are managed, documented, and coordinated. Furthermore, it establishes consistent procedures, minimum standards, operating and maintenance (O&M) criteria for equipment and systems owned and operated by Reclamation. Other technical documents may be referenced for associated equipment or systems that are discussed within this document.

Operation and maintenance requirements are based on industry standards and experience. However, maintenance requirements may vary based on equipment condition and past performance, and sound engineering practices and maintenance management should be employed for special circumstances. Manufacturer recommendations and instructions should be consulted for additional maintenance that may be required beyond what is stated in this manual.

Objectives are:

1. The safety of personnel.
2. Integrity and reliability of the Reclamation power and water systems.
3. Protection of equipment and the environment.
4. Service to the customer.

This document covers all primary mechanical components associated with hydroelectric and large pump units including turbines/impellers and generators/motors. The reference to "large pumps" in this document refers to pumps used for water conveyance systems, not to auxiliary

pumps (e.g., cooling water, oil, sump pumps, etc.). For guidance on auxiliary pumps see Facilities Instructions, Standards, and Techniques (FIST) 2-6, Maintenance of Auxiliary Mechanical Equipment.

1.2 Reclamation Standard Practices

FIST manuals are designed to provide guidance for maintenance and testing on equipment in Reclamation's facilities. There may be multiple ways to accomplish tasks outlined in this document. Facilities may exercise discretion as to how to accomplish certain tasks based on equipment configurations and available resources.

Reclamation's regions, Power Resources Office (PRO), and Technical Service Center (TSC) agree that certain practices are required to be consistent across all Reclamation facilities. Mandatory FIST procedures, practices, and schedules that appear in **{Red, bold, and bracketed}** or **[Black, bold, and bracketed]** text are considered Reclamation requirements for the O&M of equipment in power facilities. RM D&S FAC 04-14, *Power Facilities Technical Documents*, describes the responsibilities required by text designations: **{Red, bold, and bracketed}**, **[Black, bold, and bracketed]**, and plain text, within this technical document. Refer to RM D&S FAC 04-14 for more details concerning technical documents.

1.3 Maintenance Tables

Maintenance tables for tasks included within this document are included in FIST 4-1A, Maintenance Scheduling for Mechanical Equipment, and FIST 4-1B, Maintenance Scheduling for Electrical Equipment.

1.4 Manufacturer Recommendations

FIST manuals are designed to provide guidance for maintenance and testing on equipment in Reclamation's facilities. Due to the vast difference in equipment design, consultation of equipment owner's manual and manufacturer recommended maintenance should be conducted when developing job plans. For new equipment not following the manufacturer guidance may void the warranty. If there is a discrepancy between the FIST and the manufacturer recommendations, the more stringent shall be adopted in the job plan; unless there is a reason that a less restrictive maintenance practice is warranted which, the variance or deviation process as outlined in Reclamation Manual FAC 04-14 must be followed.

1.5 FIST Revision Requests

The FIST Revision Request Form (POM-226) is used to request changes to a FIST document. The request will include a summary of the recommended changes and a basis for the revision or new FIST. These forms will be submitted to the Manager, Power Resources Office. The PRO Manager will keep a list of Revision Requests for each FIST and include these in the next scheduled revision unless it is so important the change is priorities sooner.

1.6 Mechanical Database

The Turbines and Pumps Group at the TSC has created and maintaining a Mechanical Equipment Database. All Reclamation employees have access to the database which contains test data, operating data, and general information about the following:

1. Turbines
2. Governors
3. Gates and valves
4. Pressure vessels
5. Penstocks
6. Elevators
7. Hoists
8. Cranes

Some benefits of the system are as follows:

1. Visibility of other facilities within Reclamation with similar equipment – For example, find all Reclamation facilities with Obermeyer Gates.
2. Critical tool for facility reviewers – Reviewers can obtain printable forms from the database website for each asset being reviewed. The form can be taken to the site, to compare and update information.
3. Track equipment testing frequencies and critical data comparison. For example, gate test results can be compared to the previous gate test results and an increase in operating pressures or opening/closing times can be indicative of gate repairs being required.
4. Mechanical inspectors/reviewers for both Power Reviews and the Dam Safety CR exams use the database to obtain updated testing and inspection dates for gates, valves, pressure vessels, and penstocks.

The link to the Mechanical Equipment Database is: <https://mechdb.usbr.gov/MechDB/>.

FIST Volume 2-12
Mechanical Maintenance of Hydroelectric
and Large Pump Units

When tests and alignments, as outlined in FIST 4-1A or as outlined in the database, are completed, submit the recorded data to the Turbines and Pumps Group (bordromechequipdb@usbr.gov). There is a service agreement established to update the Reclamation's Mechanical Equipment Database to keep it accurate by TSC. The O&M review programs use this database to ensure tests and alignment are up to date and are being tracked.

DRAFT

2.0 Hydroelectric and Large Pump Unit Description and Maintenance

The rate at which unit components wear often accelerates after a problem initially arises. This makes regular turbine and pump inspections critical for a well-running facility so that potential problems are found and mitigated prior to forcing an unexpected outage. The inspections and maintenance of these units should be well documented in inspection reports so that trends of component degradation or signs of problems are documented. **[Inspection reports detailing what work was performed during an inspection should be filled out to record data obtained during the inspection.]** POM forms can be utilized to aid in this documenting process. A Computerized Maintenance Management System (e.g., MAXIMO, CARMA, or Excel) capable of trending data which meets the intent of the POM forms are acceptable alternatives.

The following sections detail how critical turbine and pump components work, potential problem areas, and maintenance that should be conducted on the turbines and pumps.

2.1 Hydraulic Turbines

Hydraulic turbines are classified as either reaction turbines or impulse turbines, depending on the type of hydraulic action which converts the pressure or potential energy to rotating or kinetic energy.

2.1.1 Reaction Turbine (Rotating Energy Conversion)

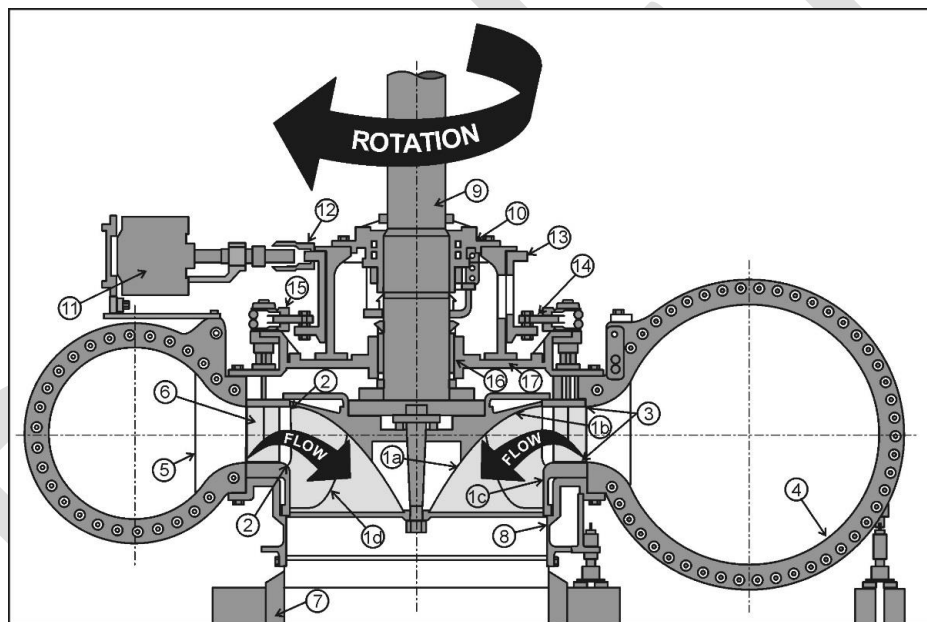
Reaction turbines include the Francis and the propeller types. The head pressure in a reaction turbine is only partially converted to velocity. While the reaction turbine obtains some power from the impulse force from the velocity of the water, most of its power results from difference in pressure between the top and bottom of the runner buckets.

The Francis turbine (figure 1) is very similar in construction to a volute pump with a closed impeller. Water entering the spiral case or scroll case is directed to the turbine runner (photo 1) by the guide vanes and the wicket gates. The wicket gates, controlled by the governor through hydraulic servomotors, control water flow to the turbine.

A propeller turbine is similar in appearance to a boat propeller. Water is directed and controlled in much the same manner as with the Francis turbine. A variation of the propeller turbine is the Kaplan turbine (figure 2) which features adjustable blades that are pivoted to obtain the highest efficiency possible at any load.

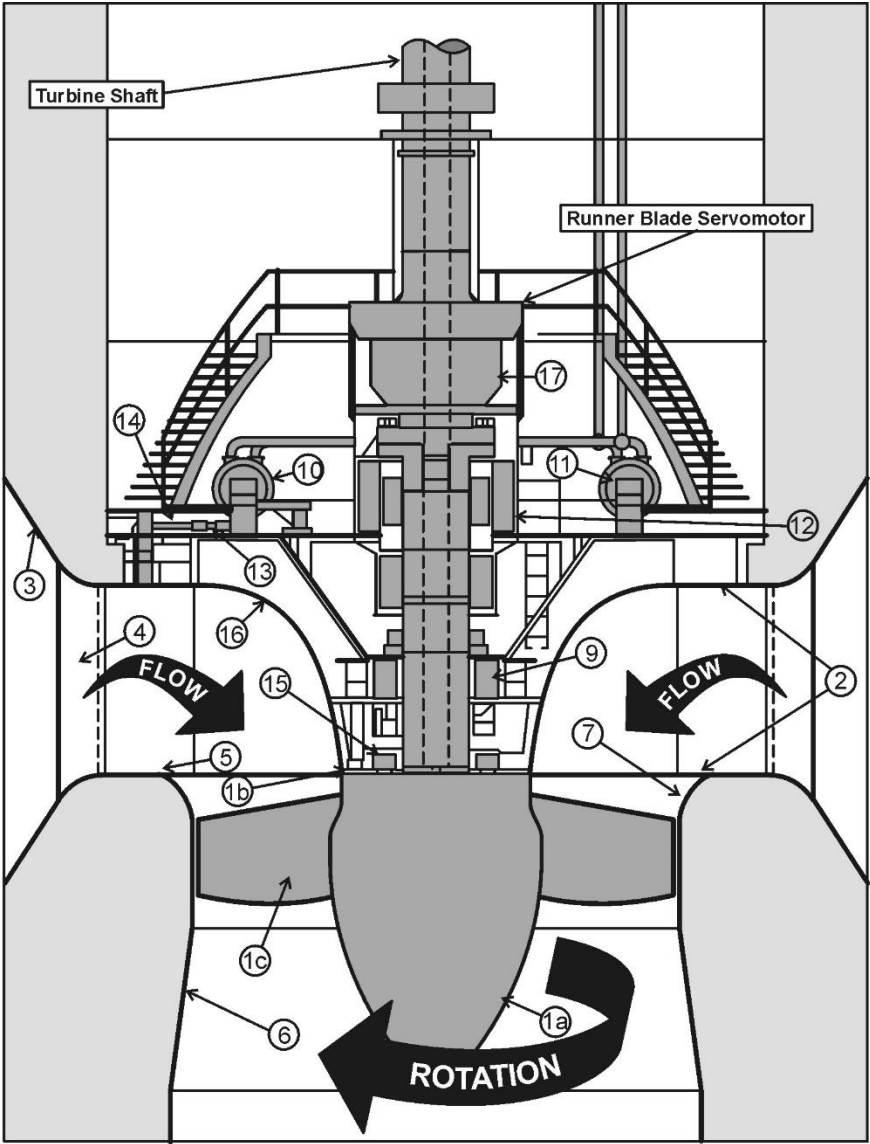


Photo 1.—Turbine runner



Parts of a Francis Turbine	
1a	Runner Cone
1b	Runner Crown
1c	Runner Band
1d	Runner Bucket
2	Wearing or Seal Ring
3	Facing or Curb Plates
4	Spiral or Scroll Case
5	Stay Vane
6	Wicket Gate
7	Draft Tube
8	Discharge Ring
9	Turbine Shaft
10	Turbine Guide Bearing
11	Wicket Gate Servomotors
12	Servomotor Connecting Rod
13	Wicket Gate Operating or Shift Ring
14	Wicket Gate Link
15	Wicket Gate Arm
16	Packing or Stuffing Box (Mechanical Seals)
17	Head Cover

Figure 1.—Francis turbine.



Parts of a Kaplan Turbine	
1 Turbine Runner	8 Turbine Shaft
1a Runner Cone	9 Turbine Guide Bearing
1b Runner Hub	10 Wicket Gate Servomotors
1c Runner Blade	11 Servomotor Connecting Rod
2 Facing or Curb Plates	12 Wicket Gate Operating or Shift Ring
3 Sprial or Scroll Case	13 Wicket Gate Link
4 Stay Vane	14 Wicket Gate Arm
5 Wicket Gate	15 Packing or Stuffing Box (Mechanical Seals)
6 Draft Tube	16 Head Cover
7 Discharge Ring	17 Runner Blade Servomotor

Figure 2.—Kaplan turbine.

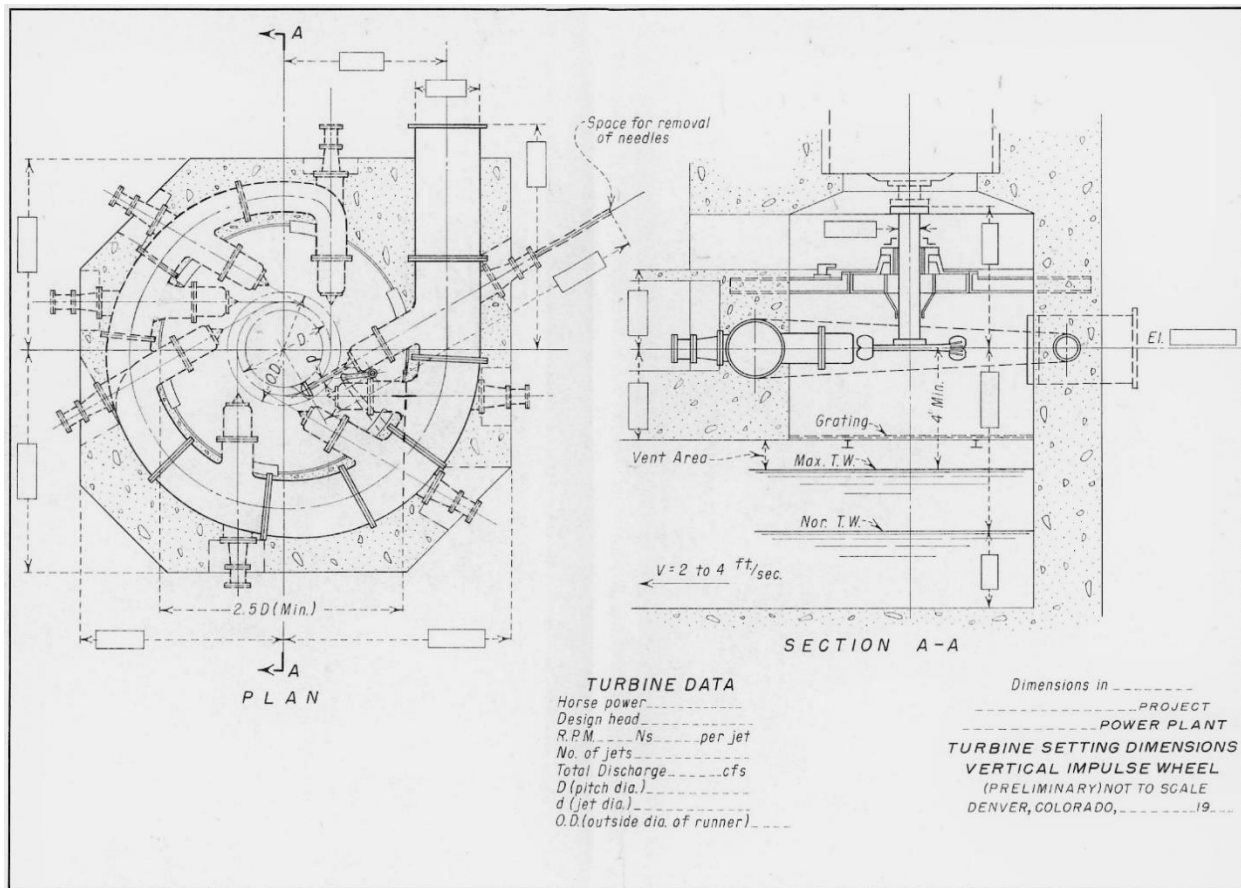


Figure 3.—Impulse (Pelton) turbine

2.1.2 Impulse Turbine (Kinetic Energy Conversion)

Impulse turbines are represented by the Pelton type turbine (figure 3). Impulse turbines convert all available head into fluid velocity or kinetic energy through the use of contracting nozzles. The jets of water from the nozzles act on the runner buckets to exert a force in the direction of flow. This force, or impulse, rotates the turbine. Impulse turbines primarily are used for heads of 800 feet or more, although they are also used in some low-flow, low-head applications.

Water flow to an impulse turbine is controlled by a needle valve. The position of the needle valve is controlled by a governor to change speed or load. A moveable deflector plate, controlled by the governor, is positioned in front of the nozzle to rapidly deflect the water away from the turbine during a load rejection.

2.2 Large Pumps (Water Conveyance Pumps)

Pumps are classified as dynamic and positive displacement, depending on the method the pump uses to impart motion and pressure to the fluid. Typically, water conveyance systems use dynamic pumps since they can move large volumes of water. Positive displacement pumps will not be discussed here. The prime mover for a pump may be an electric motor, a hydraulic turbine (hydro pump) or an internal combustion engine.

2.2.1 Dynamic Pumps

Dynamic pumps continuously accelerate the fluid within the pump to a velocity much higher than the velocity at the discharge. The subsequent decrease of the fluid velocity at the discharge causes a corresponding increase in pressure.

By far, the most common type of dynamic pump is the centrifugal pump. The impeller of a centrifugal pump, the rotating component of the pump which imparts the necessary energy to the fluid to provide flow and pressure, is classified according to the direction of flow in reference to the axis of rotation of the impeller. The three major classes of centrifugal impellers are:

1. Axial-flow. Pump discharge of the fluid is in plane with the shaft;
2. Radial-flow. Pump discharge of the fluid is radial (i.e., at right angles), to the shaft;
3. Mixed-flow. Discharge angle is between radial and axial; incorporates features of both axial and radial flow pumps.

Impellers may be classified further by their construction. The impeller construction may be:

1. Open. An open impeller consists of vanes attached to a central hub.
2. Semi-open. A semi-open impeller has a single shroud supporting the vanes, usually on the back of the impeller.
3. Closed. The closed impeller incorporates shrouds on both sides of the vanes. The shrouds totally enclose the impeller's waterways and support the impeller vanes.

Centrifugal pumps are also classified by the method used to convert the velocity energy to pressure that the impeller imparts to the fluid. Volute pumps use a spiral or volute-shaped casing to change velocity energy to pressure energy. Pumps which use a set of stationary diffuser vanes to change velocity to pressure are called diffuser pumps. The most common diffuser type pumps are vertical turbine pumps and single stage, low head, propeller pumps. Large volute pumps may also have diffuser vanes, but while these vanes direct the water flow, their main purpose is structural and not energy conversion.

Centrifugal pumps are further classified as either horizontal or vertical, referring to the orientation of the pump shaft. In comparison to horizontal pumps, vertical pumps may take up less floor space; the pump suction can be positioned more easily below the water surface to eliminate the need for priming; and the pump motor can be located above the water surface to prevent damage in the event of flooding. Vertical pumps can be either dry-pit or wet-pit. Dry-pit pumps are surrounded by air, while wet-pit pumps are either fully or partially submerged. The dry-pit pumps commonly are used in medium to high head, large capacity pumping plants. These large dry-pit pumps are generally volute pumps with closed, radial flow impellers.

2.3 Common Component Damage

Pump impellers, turbine runners, and their related components may be damaged by a number of different actions—the most common actions are cavitation erosion (photo 2), abrasive erosion, and corrosion. The appropriate repair procedure will depend on the cause of the damage.

Cavitation is the formation of vapor bubbles, or cavities, in a flowing liquid subjected to an absolute pressure equal to, or less than, the vapor pressure of the liquid. These bubbles collapse violently as they move to a region of higher-pressure causing shock pressures which can be greater than 100,000 pounds per square inch (psi). When audible, cavitation makes a steady crackling sound similar to rocks passing through the pump or turbine. Cavitation erosion, or pitting, occurs when the bubbles collapse against the metal surface of the impeller or turbine runner—most frequently on the low-pressure side of the impeller inlet vanes or turbine buckets. Cavitation cannot only severely damage the pump or turbine, but it also can reduce substantially the pump or turbine's capacity and, therefore, lessen the efficiency.



Photo 2.—Cavitation damage on turbine runner.

Abrasive erosion is suspended solids, such as sand, removing metal as the liquid flows through an impeller or turbine. The rate of wear is directly related to the velocity of the liquid, so wear will be more pronounced at the discharge of the nozzle of impulse turbines, near the exit vanes and shrouds of pump impellers and near the leading edge of reaction turbines buckets where the liquid velocity is highest.

Corrosion damage (photo 3) to submerged or wet metal results from an electrochemical reaction. The electrochemical reaction occurs when a galvanic cell is created by immersing two different elements in an electrolyte, causing an electric current to flow between the two elements. The anode, or the positive electrode of the cell, gradually dissolves as a result of the reaction. With the water acting as an electrolyte, irregularities, such as variation in surface finish or imperfections in the metal's composition, create small galvanic cells over the entire surface of the metal. Corrosion damage occurs as the anodes of these cells dissolve. Corrosion, unlike abrasive erosion, is generally independent of the liquid velocity. Pitting caused strictly by corrosion will be uniform over the entire surface.



Photo 3.—Corrosion damage on wicket gates and stay vanes.

Diagnosing the problem can be difficult, as the damage may be caused by more than one action. As a metal corrodes, the products of corrosion form a protective film on the metal surface. This film protects the base metal from further corrosive attack. An erosive environment will tend to remove this film, leaving the metal susceptible to corrosion damage. Similarly, where cavitation erosion is occurring, the metal will be prone to further damage from corrosion.

Severe erosion or corrosion damage may warrant replacing the damaged parts with parts constructed of a material that is more erosion or corrosion resistant. If severe cavitation erosion occurs during normal operation, a new impeller, runner, or other design changes may be required. Obviously, replacing an impeller or other major components can be a very expensive endeavor and should only be done after careful economic analysis. Some factors to consider when making an analysis are the cost and effectiveness of past repairs and any gain in efficiency or output that may be obtained by replacement.

Except for severe cases, repair instead of replacement is the most economical solution. The repair procedure will depend on the cause of the damage. Welding is the most successful method of repair for cavitation damage. Repair with non-fusing materials, such as epoxies and ceramics, generally is not successful because the low bond strength of these materials, usually less than 3,000 psi, is not capable of withstanding the high shock pressures encountered during cavitation. Prior to any weld repair, a detailed welding procedure should be developed. Welding, performed incorrectly, can cause more damage, by distortion and cracking, than the cavitation did originally. Cavitation repair is discussed in more detail in FIST Volume 2-5, Turbine Repair.

Corrosion or erosion damage, if the pitting is deep enough, can also be repaired by welding. If the pitting is not caused by cavitation, other coatings or fillings may be acceptable. The epoxies and ceramics discussed earlier, if properly applied, can be helpful in filling in pitting damage caused by corrosion or erosion. In a corrosive environment, a coating of paint, after the original contour has been restored, can offer protection by forming a barrier between the metal and the electrolyte and preventing the electrochemical reaction.

To be effective, erosion resistant coatings must be able to withstand the cutting action of the suspended abrasive. A coating of neoprene has been proven successful for sand erosion protection. Other available coatings have also been proven to resist erosion, but many of these coatings can be difficult to apply and maintain, and because of coating thickness, may restrict water passages. Choose erosion resistant coatings based on the design of the turbine or pump and the severity of erosion.

Cracks may appear which are caused by localized residual stress or solid objects striking the blades of the unit. Records should be kept on the locations and lengths of these cracks. A crack can relieve the residual stress and no further cracking will develop. Holes drilled at the ends of the crack, a procedure known as stop drilling, will often arrest the growth of the crack. Crack repair is discussed in more detail in FIST Volume 2-5, Turbine Repair.

2.4 Runners and Impellers

The runner or impeller is the heart of the equipment. It is used to convert all the possible energy to drive the turbines' shaft and generator or motor, or to move the system fluid to the desired location. The runner or impeller will utilize buckets or blades to accomplish this task at the same time trying to reduce the effects of cavitation. The buckets or blades may or may not have a band

or crown which ties them together. Additionally, the runner or impeller may have a cone and air venting to help with the hydraulic fluid flows. A large amount of time, money and energy was spent on this component design to optimize the size, shape, material, and service life of the runner or impeller. Proper inspection and maintenance are critical to further maximize the life of this component. If repairs are required, improper repair techniques could be more detrimental than performing no repairs.

2.4.1 Maintenance of Runners and Impellers

The following should be completed during regularly scheduled outages to ensure the integrity of hydraulic turbines and pumps:

[Inspect and document turbine runner or pump impeller condition.]

1. Visually inspect for cavitation, corrosion, erosion, and cracking.
 - a. The inspection should be made from both the draft tube area below the runner and from the stay ring/wicket gate area in the spiral (or semi-spiral) case.
 - i. Inspection from the draft tube area should normally be done from a temporary maintenance platform installed below the runner. Most areas of the runner which are susceptible to cavitation damage can be seen from the draft tube side. The leading edge of the blades, however, can best be inspected from the wicket gate area. On small units where access to the runner from the wicket gate area is poor, a polished metal mirror can be used for observing the leading-edge area from the draft tube side. The runner blades should be permanently numbered. The wicket gates may be identified by referencing them to the baffle vane.
 - ii. Adequate lighting is necessary for a thorough inspection-the stronger the light source the better. When the runner erection platform is in place, photographic-type lighting is optimum. For the wicket gate area, large portable battery powered lights are usually sufficient. A drop-cord-type light is also suitable for difficult areas. For safety, ground fault detectors are necessary in the power supply to the turbine water passages. Alternately, a low voltage direct current (dc) power source should be used.
2. Conduct non-destructive testing if visual inspection identifies areas of concern where cracking could be present. Utilize dye penetrant or a magnetic particle test to identify where cracking on the blades or buckets has occurred.
 - a. Likely areas of cracking are at joints, welds, and corners in materials.

3. Record condition of blade surfaces (pits and significant material loss). POM form 160-163 are runner inspection report documents to aid in monitoring and tracking of issues. For details not in POM form 160-163 it is recommended that a checklist be prepared to ensure that all parts of the turbine/impeller are inspected, and that all areas of cavitation damage are recorded on sketches or in tabular form. The records should include the following:
 - a. Date of inspection.
 - b. Number of hours of operation and the generation (kWH) since the previous repairs and/or inspection.
 - c. Operation limits (i.e., net head, tail-water level, low flows, and any incidence and duration beyond these limits.
 - d. Overall area of each area of pitting, as well as the average depth and maximum depth.
 - e. Dimensions of damaged areas from the leading and trailing edge of the blades.
 - f. Photographs of the damaged areas and of subsequent repairs.
 - g. When taking photographs, the blade number, the date of the inspection, and dimensions of the pitted area should be clearly marked on the blade for reference.

[Repair runner or impeller when significant damage begins to occur.]

1. See FIST 2-5, Turbine Repair for more details.

2.5 Turbine Air Vent or Pressurized Air Injection Systems

Air vents or pressurized air injection systems which are designed to help improve turbine efficiency and reduce rough zones. Nearly all Francis type turbines have a load range or wicket gate opening range referred to as a rough zone in which vibration and draft tube pressure fluctuations increase greatly. This increase in vibration is due to the formation of a rotating vortex in the draft tube.

Reclamation makes a conscious effort, in most cases, to limit operation in turbine rough zones. Air vents are provided on all Francis units to allow atmospheric air to enter the low-pressure zone in the draft tube, below the runner, helping reduce vortexes created by rough zone loading. In addition, some facilities also have a pressurized air injection system. The valves to the vents or pressurized air injection system are operated either by cams or by solenoids and are typically

opened based on wicket gate position. This can have a great effect on the vibration levels in the rough zone or may have little or no effect. The only way to verify the effectiveness is to perform testing while observing vibration and pressure fluctuations.

2.5.1 Maintenance of Turbine Air Vents or Pressurized Air Injection Systems

[Visually inspect and perform maintenance of turbine air vent or pressurized air injection system valves]:

Manually operated valves:

1. Verify the valve moves freely if equipped with a manual override.
2. Inspect for loose, missing, damaged fasteners on the valve and any cam actuated components.
3. Lubricate bearings or bushings (if applicable) and verify free movement.

Solenoid/Motor operated valves:

1. Verify operation and inspect electrical components.

Pressurized air injected systems:

1. Verify air injection system is supplying appropriate pressure.

[Verify the turbine air vents or pressurized air injection systems are set to open at the correct load or wicket gate opening to mitigate rough zone operation when a new rough zone has developed.]

If air vent valve settings were found to be correct, there may be internal valve components that have damage. Inspect internal valve components and repair as required. If the new rough zone still exists, equipment operating set points should be evaluated and reestablished.

2.6 Wearing Rings

Wearing rings, or seal rings, provide a renewable seal or leakage joint between a pump impeller or a turbine runner and its casing. The location of the wearing rings depends on the design of the pump or turbine. Francis turbines and most closed impeller pumps generally have wearing rings in two locations, although some pump impellers may only have a suction side wearing ring.

These rings may be located on the runner or impeller as well as the head cover and scroll case. Propeller turbines, open impeller, and many semi-open impeller pumps do not have wearing rings, but instead rely on a close fit between the runner or impeller vanes and the casing to control leakage. Some designs include an inner labyrinth seal on the headcover which greatly reduces the hydraulic downthrust on the unit. In some cases, hydraulic downthrust forces can begin to cause excessive thrust bearing heating and runout issues.

As the name implies, these rings can wear over time. As the clearance increases, efficiency can decrease and the unit can be subject to changing hydraulic forces. At some point these issues will drive the need to be replaced or renew the wear rings to restore operational efficiency. If a design does not include replaceable wearing rings, it may be necessary to build up the wearing ring area by welding or some other acceptable process and machining back to the original clearances. For information on wearing ring replacement see FIST Volume 2-5, Turbine Repair.

2.6.1 Wearing Ring Maintenance

Complete the following maintenance items on unit wearing ring:

[Verify the clearances on the wearing ring.]

1. Position the runner in the same position, this is typically an arrow or known position of the generator/motor rotor. If this is not done, measurements may not be consistent.
2. Check the top and bottom wearing ring clearances at four points, 90° apart. Due to access, feeler gages are normally used for this check. A best practice is to measure opposing points at the same time (i.e., leave one feeler gauge in place while checking the opposite point). If this is not done measurements may not be consistent.
 - a. Compare clearances to the design clearance and previous readings for trend analysis.

[Remove the runner or impeller and renew or replace wearing rings.]

When the wearing ring clearance exceeds 200 percent of the design clearance, and the unit is having thrust bearing heating issues or excessive runout issues, the subject of wear ring replacement or renewal should be reviewed with the TSC's 8470 Turbine and Pumps Group design engineers.

2.7 Pressure Boundary Components

Turbines and pumps contain many pressure boundary components which are designed to keep system fluid inside the component and out of the facility. These components include but are not limited to the scroll case and draft tube, the head cover, the turbine pressure relief valve, shaft

seal components, man doors, and associated fasteners. Many of these components are encased in concrete and can only be inspected internally.

Components which form a pressure boundary and are secured in place by fasteners are referred to as a Critical Bolted Connections. A failure of these connection could result in catastrophic loss of life and destruction of the facility or major flooding. Proper installation, inspection, assembly, and maintenance of these components are critical to personnel safety and equipment longevity.

2.7.1 Scroll Case and Draft Tube

The scroll case and draft tube transfer fluid in to and out of the runner or impeller. The construction consists of multiple segments of metal which may be welded or riveted together and fully or partially encase in concrete to help stabilize and reduce equipment stresses due to the directional fluid changes. Dependent on the material, the inner surface may be coated or lined with a protective material (e.g., coal tar, epoxy paint, etc.) to minimize material loss due to corrosion, erosion, or cavitation and may need to be renewed at times. These components usually have equipment access doors typically call man doors which may open inward or outward. Outward opening man doors are a critical bolted connection.

2.7.1.1 Scroll Case and Draft Tube Maintenance

[Inspect the condition of the spiral case and draft tube or pump casing and suction inlet.]

Note: All equipment leakage inspections must be done while the equipment is still watered up.

1. Inspect the condition of the interior lining and coating.
 - b. Repair as required. If the condition of the interior coating is heavily damaged such that spot repairs are no longer effective, a full relining may be necessary. Remove the coating, prepare the surface, and recoat the entire surface.
2. Inspect for cavitation, cracking, erosion, and corrosion.
 - a. Weld-repair areas with significant cavitation damage of the draft tube liner. Draft tube liners severely damaged by cavitation may be repaired by cutting out the damaged area and welding plates in place that have been rolled to the proper

- b. diameter. When this is done a small amount of the existing concrete should be removed and the new plate should set in place with a new layer of grout to provide ensure no voids are created.
3. Perform an impact test to check draft tube or suction liner for voids between the liner and concrete.
 - a. Grout if necessary. Monitor leaks between concrete and the spiral case, pump casing, draft tube, or suction tube. If excessive or if an increase is noted, locate and repair the source of the leak.
4. Inspect riveted and welded joints.
 - a. Check for leaks, cracks, corrosion, and significant material loss.
 - b. Repair as required.
5. Inspect man doors.
 - a. Check for leaks and replace gaskets as necessary.
 - b. Inspect door hinges for deterioration.
 - c. Inspect fasteners for damage and replace as necessary.
 - d. When reinstalling the man door, lubricate and torque fasteners; document final torque.

2.7.2 Head Cover

The head cover (photo 4) is a large weldment, or casting, that retains the wicket gates and associated gate components, supports the turbine guide bearing and shift ring, retains the upper wear ring, and retains water above the turbine runner. It forms a pressure boundary by connecting to the scroll case with fasteners. The head cover is an important critical bolted connection. Once installed a head cover can be difficult to inspect but will need very little maintenance.



Photo 4.—Head cover.

2.7.2.1 Head Cover Maintenance

[Inspect the condition of the headcover.]

1. Inspect headcover to scroll case joint for leaks and monitor if discovered.
2. Verify all drain passages are clear and drain freely.
3. Inspect coating for gross deterioration and repair if heavy corrosion is occurring.
4. Inspect accessible portions of the head cover for major cracks.
5. Inspect for loose, missing or heavily corroded fasteners.

2.7.3 Turbine Pressure Relief Valves

A few turbines in Reclamation facilities (Hoover, Flatiron, Estes, Pilot Butte, and Pole Hill) are equipped with pressure relief valves. These valves are sometimes supplied on high-head Francis turbines to limit the pressure rise in the penstock following a load rejection. The relief valves are connected to the wicket gate linkage and are designed to open following a quick wicket gate closure, as would occur during a load rejection. The valve then will close slowly.

Using pressure relief valves allows a quicker closure of the wicket gates which limits the overspeed of the unit. The design of these relief valves varies with manufacturer, but most require the penstock to be watered up to test the operation of the valve as they use water pressure to operate. Because of this requirement, the only way to test the operation of these valves is to perform a load rejection test. Some of the pressure relief valves are also designed to be operated

manually so they can be used as bypass valves to allow water to be bypassed if the turbine is not in operation.

2.7.3.1 Turbine Pressure Relief Valves Maintenance

Maintenance tasks are currently discussed in FIST 4-1A, Maintenance Scheduling for Mechanical Equipment appendix A.

2.7.4 Fasteners (Critical Bolted Connections)

Fastener is a general term for bolts, through-bolts, studs, cap screws, nuts, and various other names. Fasteners are a simple machine, but extremely complex. Entire books have been written on fasteners. When inspected, lubricated and installed correctly can provide an extremely strong and reliable connection on a piece of equipment.

In rare occasions these events are associated with design elements (proper material properties), but most events occur due to failures in the quality control or assembly process. Some conditions that may occur are:

Fastener Material Specifications

Fastener material did not have the physical requirements specified by the manufacturer.

Fastener Fatigue

Proper preload or tensioning of a bolt or stud can eliminate, or at least greatly reduce, any chance of fatigue failure from reduced cyclic loading. High vibration and pressure fluctuations, coupled with the questionable preload on the studs, can lead to the fatigue cracking of the studs and their ultimate failure.

Fastener Corrosion

Fastener material properties should be selected based on the environment and system conditions it will be exposed to. In some extreme cases corrosion can occur which causes material loss and a reduction in fastener strength.

Fastener Preload

The proper preload is important for two reasons. One reason is to limit cyclic loading of studs and preventing fatigue type failures in a condition with too little preload. The other is to prevent too much preload which could result in fastener damage by exceeding the yield strength and causing material failures.

Preload is accomplished by applying torque (a twisting or turning force) to fastener which causes the fastener to stretch to its ideal point of strength where it no longer feels any system stresses. Many variables can affect preload such as tooling used, as well as frictional forces associated thread defects and fastener lubricants. When applying a preload, the torque is normally applied to one part of the fastener while the other part is restrained. Example, a nut is turned while the bolt

remains stationary. Also, note it is important when applying torque to through-bolts that only the nut be turned. The through-bolt in this scenario sees additional friction from the hole. If the torque was applied to the bolt an improper preload could be achieved. It is also important to remember that lubricants are applied to all fastener contact surfaces (e.g., threads and face of the nut).

There are several ways to precisely preload a bolt or stud. The most accurate is to measure the length of the bolt or stud before and after tightening the nut and then calculate the final load. With a head cover stud, the only way to achieve this is with an ultrasonic measurement system. To use an ultrasonic system, the top and bottom surface of the stud must be machined flat and parallel. The most accurate method using the ultrasonic system is to mount the transducer to the top of the stud prior to tensioning, and then observe the stretch in the stud as the nut is tightened with a hydraulic wrench. A pneumatic impact wrench could also be used by taking a reading with the nut loose and taking subsequent readings after the nut is tightened with the impact wrench. Some error may be introduced as transducer is removed and replaced as the wrench is used.

Torque values can be used to measure the loading on studs, but inaccuracies are much higher than measuring actual stretch or elongation of the studs. The torque required to turn a nut not only includes the force required to stretch the stud, but also includes the force required to overcome friction in the threads and the friction between the nut and its mating surface. Depending on the condition of the threads, a given torque value on several seemingly identical nuts can equate to a large difference in actual loading. It is generally accepted that using torque values to load bolts or studs can result in loads varying ± 25 percent (%). To limit the error, the threads of both the nut and the stud should be inspected, repaired if necessary, and an appropriate lubricant applied. Any bolting procedure must provide the specifications of the thread lubricant as part of the procedure. Note that the type of thread lubricant can change the frictional coefficient and thus change the required torque value.

Another method of preloading a bolt or stud is referred to as the turn-of-the-nut method. This method is used extensively in structural bolted connections. With this method the nut is tightened “snug tight,” the nut is match marked in this position, and the nut is rotated by an amount determined by the thread pitch, diameter, and length of the stud. This method eliminates the error introduced by friction. The specific turn-of-the-nut procedure recognized by Research Council of Structural Connections is widely available in their publications and is referred to by numerous organizations and fastener companies. This procedure was developed specifically for permanent structural connections. The procedure involves loading the bolts or studs beyond their yield point. As structural connections are not intended to be disassembled, this is acceptable. On temporary connections that are designed to periodically be disassembled, such as head covers, this procedure would be acceptable only if it is recognized that the studs could not be reused. As head cover studs are usually expected to be reused, a preload below the yield point is desired. A specific angle of rotation should be determined based on the specific threads per inch, bolt yield strength, and bolt length for each unit if this procedure is used.

Hydraulic bolt tensioners can also be used to accurately load studs. The tensioner attaches to the top of the stud above the nut. Hydraulic force is applied to stretch the stud a predetermined amount and the nut is tightened snugly. When the hydraulic force is removed, the bolt relaxes against the nut. This method may take some experimentation to get the final desired stretch, but it has been successful in providing accurate and consistent loading of studs in various industries. Hydraulic tensioners require a length of exposed thread above the nut equal to 1 1/2 times the bolt diameter. Thus, in most cases, new studs would have to be procured.

2.7.4.1 Fasteners Maintenance (Critical Bolted Connections)

Normally fasteners require very little maintenance other than a visual inspection. The most important tasks associated with fasteners is the proper installation of the fastener.

Besides a load sensing washer, there is no way to measure the current loading on fasteners on units in service. The only way to absolutely ensure that the studs on units in service are preloaded to their optimum value would be to completely remove all the nuts, clean and repair the threads of both the studs and nuts, apply an appropriate lubricant, and reinstall the nuts to a specified torque or stud stretch value. While this would provide the optimum loading, it would be very time consuming and adequate fastener loading can be determined by other methods and is not expected to be performed on a routine basis.

When replacing fasteners, material should be determined from the manufacturer's drawings and replaced in kind. Material certified fasteners shall meet American Society of Mechanical Engineers (ASME) standards for material conformance and quality assurance testing standards. If the fastener material or original specifications cannot be determined, contact a qualified mechanical engineer or Reclamation's Technical Service Center, Turbines and Pumps Group for assistance. A sample of the fastener lot may need to be tested to ensure fasteners material and strength requirements are met. **[New fasteners used in a critical bolted connection shall be certified for material specifications and a record maintained.]**

Thoroughly inspect fasteners when components are disassembled. This may be done visually once cleaned or by other nondestructive methods. Fasteners should not have missing or damaged threads, cracks, or signs of elongation. Replace fasteners if any of these issues are found. Minor defects such as burrs and nicks may be removed. Some fasteners can be checked for cracks by magnetic particle and/or ultrasonic testing, but this is normally done during major equipment overhauls.

When torquing fasteners to establish preload, a torque wrench, torque multiplier, hydraulic torque wrench or pneumatic impact wrench shall be used. Equipment should have an accuracy no greater than $\pm 5\%$ and shall be calibrated. The torque applied or the bolt elongation shall be documented in the equipment history file. It is also important to remember some compressible gasket materials may experience creep (i.e., relaxation) while the preload is established. This may result in multiple tightening sequences until the preload has stabilized.

Each facility shall [**Identify, calculate preload, and maintain a record of assembly of each critical bolted connection.**] The preload calculations shall be performed by a qualified mechanical engineer. These values should have a tolerance and be included in job plans or available for reference during the assembly of critical components. If equipment or material designs change, the preload calculations shall be re-evaluated.

When assembling critical bolted connections, complete the following:

1. Clean and inspect fasteners.
2. Lubricate fasteners contact surfaces.
3. Assemble the connection and install all fasteners snug.
4. Use a torque device to incrementally increase torque using an appropriate tightening sequence (e.g., star pattern) until preload is established.
5. Document final preload value, equipment calibration information, date and who performed the action and maintain a record of this information in an appropriate equipment history file until the next time the critically bolted connection is disassembled.

2.8 Wicket Gates

Wicket gates (photo 5), or guide vanes, control and direct the flow of water to the turbine runner. Wicket gates are generally supported in two or three bearings or bushings. Common wicket gate issues include foreign objects lodged between two wicket gates, excess friction within bushings, and excess friction between gate leaf ends and upper or lower facing plates. To prevent wicket gates from breaking or stalling when this occurs, a protective device such as a shear pin or breaking link is provided (photo 6). These devices are designed to fail at a stress level that will protect the wicket gates and their operating linkages from being damaged. In addition, the wicket gate arms usually have hard stops to prevent each wicket gate from contacting the runner during a shear pin break. Wicket gate repair is discussed in detail in FIST Volume 2-5, Turbine Repair.



Photo 5.—Wicket gates and stay vanes.

Some wicket gate assemblies have been converted to greaseless systems. Considerations for greaseless bushing systems include, but are not limited to:

- Debris control in the bushing clearances
- May be used fully submerged, partially submerged, or in air
- All contacting surfaces with relative motion from servomotor to wicket gate have been considered for alterations to greaseless system
- Proper alignment of wicket gate linkage assemblies, the concentric boring of wicket gate bushings
- Procuring spare bushings for minimized O&M outage time in the event of failure
- Any installation methods that require special tooling or design configurations.

For more information on Greaseless Bushings, see Section 2.14.3.

Wicket gate heel to toe clearances and top/bottom facing plate clearances are critical to proper wicket gate operation. Wicket gate heel to toe clearances are important for proper sealing between wicket gates around the turbine, but these clearances are also important to evenly distribute the servomotor force to the wicket gates when the governor is in full squeeze. If one

wicket gate picks up more torque than other wicket gates due to uneven heel to toe loading or improper bushing wear, it is possible that shear pins (photo 6) will fail from increased cyclic loads in fatigue or even from reaching maximum shear stress of the shear pin.



Photo 6.—Wicket gate shear pin.

The facing plate clearance, heel to toe clearances and gate thrust collar wear are important for managing wicket gate leakage. Excessive wicket gate leakage can adversely affect unit operations in several ways, possibly leading to unit creep, increased unit shut down time (which could affect long term life of a thrust bearing), and potentially even to an unscheduled unit outage as the ability to control a unit is lost.

2.8.1 Wicket Gate Maintenance

Complete the following tasks to maintain unit wicket gates and facing plates.

[Check leakage past wicket gate packing.] This must be done prior to unwatering the unit.

1. Tighten packing as required.
2. Verify no missing or damaged fasteners.

[Measure wicket gate and facing plate clearances.]

1. Set Servos to 0% gate.
2. Depressurized the governor system.
3. Measure and record heel to toe clearances between wicket gates at the top, middle, and bottom of the gates. Compare to previous readings and adjust when necessary. These checks can help determine when gate bushing or servomotor linkage wear is occurring.
 - a. Note – If the heel to toe clearance is increasing on a single gate, that gate operating linkage may need adjustment. If all gates have an opening, the servomotors may need to be adjusted. If a single gate opening is not parallel, there may be bushing wear.
4. Measure and record clearances between wicket gates and the upper and lower facing plates on the heel and toe sides. These checks can help determine gate thrust collar wear.
 - a. Compare to previous readings and design clearances.
 - b. If thrust collar wear is occurring, investigate the cause and adjust if gate to facing plate contact begins to occur.

[Check wicket gates for damage.]

1. Inspect for cavitation damage, corrosion, erosion, or cracks. Mirrors and borescopes can help complete this inspection. If certain components cannot be inspected, the gates may need to be repositioned to perform a complete inspection.
2. Repair or repaint as required.

[Inspect the facing plates.]

1. Check upper and lower facing plates for scoring, corrosion, cavitation, or erosion damage.

[Check automatic greasing systems.]

1. Check for leaks, crushed or damaged piping and fittings.
2. Run greasing system through complete cycle.
 - a. Note operating pressure and cycle time.

[Check automatic greasing systems.]

1. Check for leaks, crushed or damaged piping and fittings.
2. Run greasing system through complete cycle.
 - a. Note operating pressure and cycle time.
3. Verify each lubrication point is getting grease.
4. Perform grease system manufacture recommended maintenance.
 - a. Note - Perform filter inspections or oil changes as necessary.

2.9 Servomotors and Operating Linkages

The conventional arrangement uses two gate servomotors, a gate operating ring, and linkages to attach to the wicket gates (photos 7 and 8). However, some servomotor designs incorporate individually operating servomotors for each wicket gate. The servomotor loading effort is designed to be uniformly distributed to all wicket gates.

Servomotors may have internal or external stops where the piston rests under squeeze pressure in the closed wicket gate position. It is critical that servomotor timing and pressure are achieved based on the process outlined in FIST Volume 2-3, Mechanical Maintenance of Mechanical and Digital Governors for Hydroelectric Units. If both pistons do not come to rest on the internal stops at the same time within a reasonable tolerance, then shimming one of two servomotors may be required. Imbalanced servomotors may result in radial forces applied to the turbine guide bearing (TGB) housing by the shift ring which, in a worst-case scenario, may lead to bearing damage by moving the TGB out of concentricity. To avoid large penstock pressures or damage to wicket gates, servomotors are designed to slow down prior fully closing. This is known as “cushioning”.



Photo 7.—Servomotor connecting rod.



Photo 8.—Servomotor.

2.9.1 Servomotor and Operating Linkage Maintenance

Complete the following maintenance items on unit servomotors.

[Check for worn servomotor and wicket gate linkages.]

1. Move the servomotors back and forth through its full range of motion.
2. Look for lateral movement or apparent binding in the shift ring.
 - a. Indicates worn bearing pads.
3. Look for backlash in the wicket gate linkage.
 - a. Indicates worn wicket gate bushings or damaged shear pins.

[Check oil leakage past servomotor packing glands.]

1. Look for excessive oil around the motor shaft.
 - a. Tighten packing as required.
2. Check servomotor shaft for scoring and repair as required.

[Review records for shear pin replacement for the preceding year.]

1. If there is an abnormally high number of broken shear pins for no apparent reason, visually inspect pins for signs of fatigue or check for cracks with ultrasonic equipment.
 - a. The fatigue life is usually consistent, so if several show signs of fatigue and the pins are of the same vintage, schedule replacement of all pins. If pins are failing prematurely, check amount of squeeze on the wicket gates.

2.10 Shaft Seals

The shaft seal provides the interface between the pressurized turbine water passage and atmospheric pressure at the turbine shaft. Hydraulic turbine shaft seals usually fall into two main types: compression packing or stuffing boxes, and mechanical seals.

2.10.1 Packing or Stuffing Box

Compression packing is the most common method of controlling leakage past a pump, turbine, or wicket gate shaft. The standard packing or stuffing box will contain several rings of packing with a packing gland to hold the packing in place and maintain the desired compression. Some leakage past the packing is necessary to cool and lubricate the packing and shaft. If additional

lubrication or cooling is required, a lantern ring also may be installed along with an external packing water source.

Over time, the packing gland may have to be tightened to control leakage. To prevent burning the packing or scoring the shaft when these adjustments are made, most compression packing contains a lubricant. As the packing is tightened, the lubricant is released to help lubricate the shaft until leakage past the packing is reestablished. Eventually, the packing can be compressed to a point where no lubricant remains, and replacement is required. Continued operation with packing in this condition can severely damage the shaft.

When packing replacement is necessary, remove all the old packing. The lantern ring, if equipped with one, must be removed along with all the packing below it. With the packing removed, special attention should be given to cleaning and inspecting the packing box bore and the shaft or shaft sleeve. To provide an adequate sealing surface for the new packing, a severely worn shaft or shaft sleeve should be repaired or replaced. Likewise, severe pitting in the packing box bore should be repaired. Sealing the packing against a rough packing box bore requires excessive compression of the packing. This over compression of the packing will lead to premature wear of the shaft or shaft sleeve.

A number of different types of packing are available; so, when choosing new packing, ensure that it is the correct size and type for the intended application. All the relevant conditions that the packing will operate under, such as shaft size and rotational speed, must be considered. Installing the wrong packing can result in excessive leakage, reduced service life, and damage to the shaft or sleeve.

The new packing should be installed with the joints staggered at least 90 degrees apart. It is sometimes helpful to lubricate the packing prior to installation. The packing manufacturer should be consulted for recommendations of a lubricant and for any special instructions that may be required for the type of packing being used. With all the packing and the lantern ring in place, the packing gland should be installed finger tight.

There should be generous leakage upon the initial startup after installing new packing. The packing gland should be tightened evenly and in small steps until the leakage is reduced sufficiently. The gland should be tightened at 15- to 30-minute intervals to allow the packing time to break in. The temperature of the water leaking from the packing should be cool or lukewarm, never hot. If the water is hot, loosen the packing gland until the temperature is appropriate.

2.10.2 Mechanical Seals

Mechanical seals are used in both pump and turbine applications. Mechanical seals allow very little leakage and can be designed to operate at high pressures. Properly installed mechanical seals will have a long service life and require little maintenance.

A mechanical seal on a small pump consists of a stationary and a rotating member with sealing surfaces perpendicular to the shaft. The highly polished sealing surfaces are held together by a combination of spring and fluid pressure and are lubricated by maintaining a thin film of the fluid sealed between the surfaces.

There is a wide variety of mechanical seals available for small pump applications, each having its own distinct installation procedure. Therefore, it is important to follow the seal manufacturer's installation instructions as closely as possible. The manufacturer also should provide information about the allowable shaft runout and endplay for their particular seal.

Since mechanical seals are precisely made and rely on very tight tolerances to operate successfully, great care must be taken during installation. Just a small amount of dirt or other contaminants (human hand oil) on the polished sealing surfaces can allow leakage past the seal and reduce the seal's life.

Mechanical seals used in hydraulic turbines and large pumps consist of sealing segments, usually made of carbon, held against the shaft by spring tension and lubricated by a thin film of water. These seals usually require grease lubrication prior to startup if the unit is shut down for extended periods.

Seal water is provided on most larger seals to help cool and keep the seals clean. The seal water must be clear, clean water. Some type of filtration should be installed if there is any silt or sand in the seal water supply, since contaminants can quickly damage the seals.

2.10.3 Maintenance of Shaft Seals

Complete the following maintenance items on unit shaft seals:

[Ensure the flow of shaft seal cooling water.]

1. Check the flow, record, and trend pressure of shaft seal cooling water on system gauges.
2. Check for excessive heating and leakage past the shaft seals. If leakage becomes excessive see equipment specific corrective actions below:

[Monitor shaft seals for excessive leakage and maintain per equipment specific requirements.]

1. Packing or Stuffing Box
 - a. Tighten the packing gland.
 - i. Grease the packing box (if applicable).

- ii. If leakage past packing gland is unable to be mitigated by tightening the packing gland, complete task b.
 - b. Remove old packing and lantern ring/labyrinth seal.
 - i. Clean packing box.
 - ii. Check packing sleeve for excessive wear and repair as required.
 - iii. Install new packing, staggering adjacent rings at least 90 degrees so that joints do not coincide.
2. Mechanical Seals
- a. Repair seal if excessive leakage is occurring.
 - i. Clean seal components and shaft sleeve.
 - ii. Check shaft sleeve for excessive wear and repair as required.
 - iii. Replace segments or other components as required.

[Follow manufacture recommendations for extended outages]

2.11 Bearings

Bearings locate and support the shafts of a pump or turbine and generator or motor. The bearings can provide radial support (line or guide bearings), axial support (thrust bearings), or both. The most common types of bearings are fluid film or plain bearings.

When bearings include oil level and temperature devices which feed into automatic protective trip actions and permanently installed vibration monitoring (shaft runout) and analysis equipment identified in Section 2.15, the bearing is considered a monitored bearing.

2.11.1 Fluid Film Bearings

Fluid film or plain bearings, derive their load-carrying capacity by forming an “oil wedge” as the shaft or thrust runner rotates. This “oil wedge” is similar to the fluid wedge that forms under a speeding boat, raising its bow out of the water. The force of the wedge in a bearing must be sufficient to balance the load to the bearing surfaces.

Fluid film bearings normally are used on turbines and large pumps and can be sleeve bearings (either solid or split), tilting pads, or pivoted thrust shoes. There are basically three design types for thrust bearings: adjustable shoe, spring loaded, and self-equalizing (photos 9–13, respectively). These bearings usually consist of a cast iron or steel bearing shell with a tin- or lead-based babbitt lining.

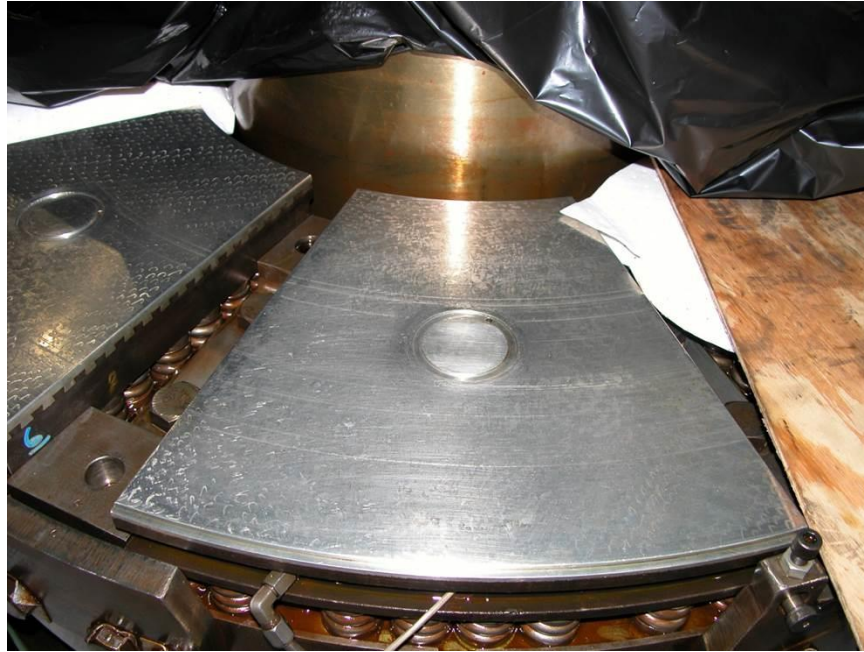


Photo 9.—Spring loaded thrust shoe bearing.

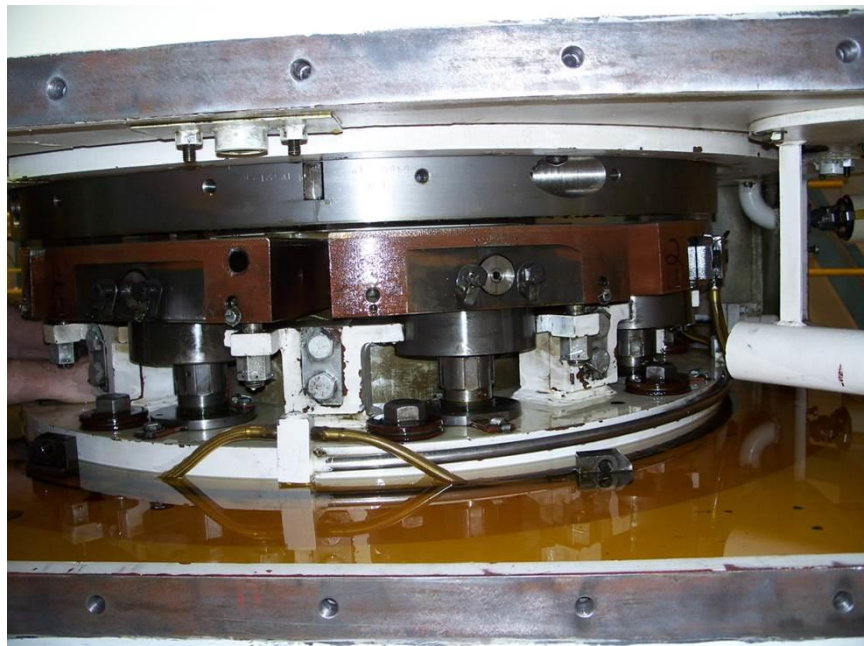


Photo 10.—Pivoted adjustable shoe thrust bearing.

There are basically two design types for guide bearings: sleeve type and segmented shoe. Sleeve type guide bearings (photo 11) are sometimes used on generators/motors and almost always on

turbines. The guide bearings are usually a cast steel shell with a babbitt bearing surface. The sleeve guide bearing totally encompasses the shaft journal. Oil grooves are cut into the babbitt to assist in distributing the oil. The oil flow may be pumped or be designed to use the dynamic motion of the shaft to pump the oil. If there are no oil grooves in a particular sleeve type guide bearing, grooves can be added to improve cooling or oil flow.



Photo 11.—Sleeve journal bearing.

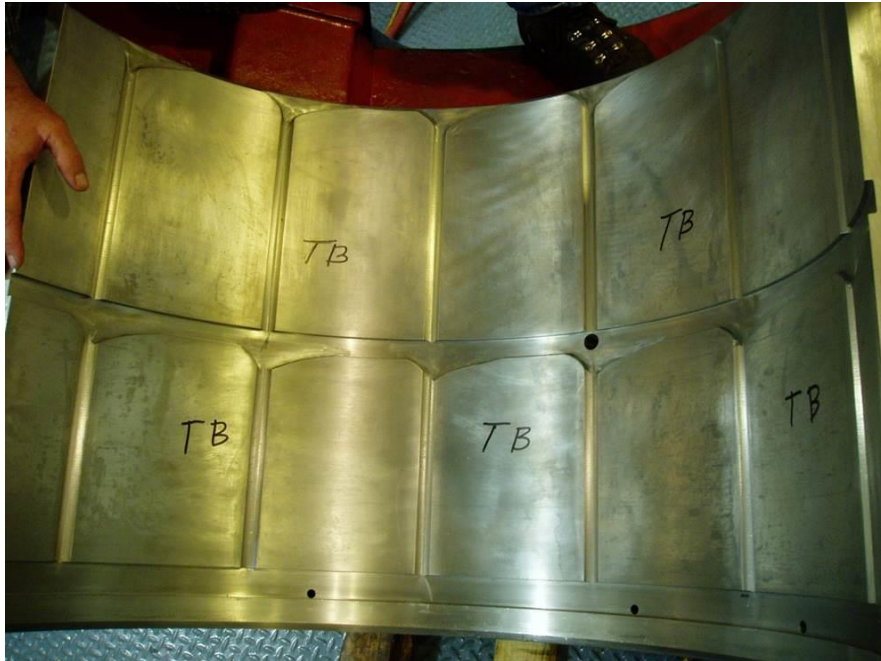


Photo 12.—Sleeve type guide bearing.

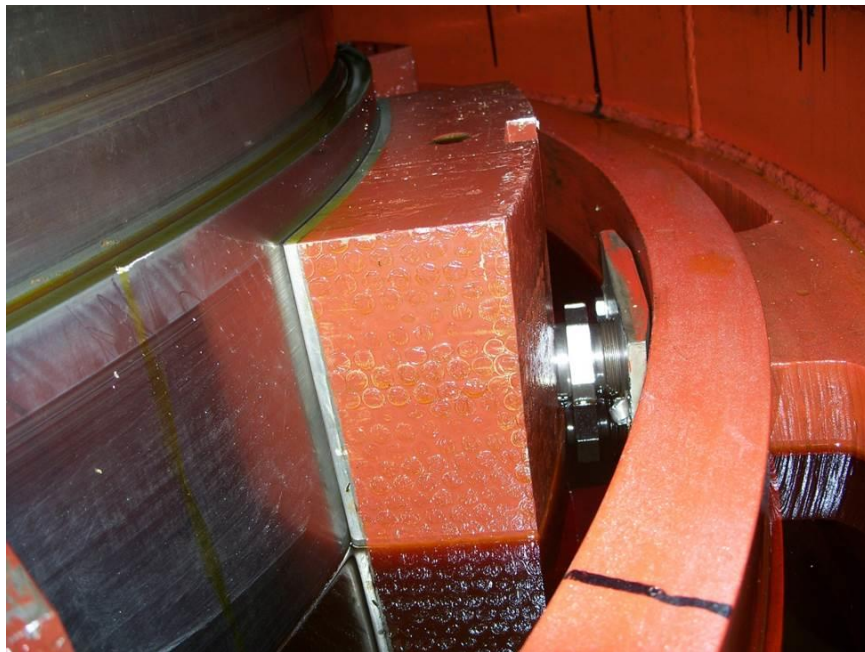


Photo 13.—Adjustable segmented shoe bearing.

Adjustable shoe guide bearings are mounted on adjustment screws to allow adjustment for clearance and center of the bearing. The individual shoes pivot to allow an oil wedge to form

through dynamic motion of the shaft. Water lubricated bearings are also usually segmented but do not pivot; the segments are typically long and are shimmed to position.

Adjustable screws, to adjust the position of the bearing shoe, come in all shapes and sizes, but they have common features. They typically move radially to the generator/motor shaft, can be locked in place, and have a hardened spherical surface that acts as a point contact to another hardened insert in a segmented shoe bearing. The hardened point contact is where the line of bearing force transfers to the bearing bracket. Inspect segmented shoe bearing adjustment screws whenever possible to verify spherical shape and hardness of the point contact are maintained over time. Hardness values are approximated near 52 Rockwell C.

Exposure to cyclic loading over time or excessive shaft runouts can lead to flattening of the spherical surfaces, increased bearing clearances, increased shaft runout, increased bearing temperatures, and possibly bearing failure. The change in shape from spherical to flat while in service changes the way the bearing shoe pivots, thus reducing designed performance.

Underhung units typically have three guide bearings: an upper generator/motor guide bearing located above the generator/motor rotor, a lower generator/motor guide bearing located below the generator/motor rotor, and a turbine guide bearing located just above the turbine runner.

Umbrella units typically have two guide bearings: a generator/motor guide bearing located with the thrust bearing below the generator/motor rotor, and a turbine guide bearing located just above the turbine runner. An umbrella unit may sometimes also have an upper generator/motor guide bearing.

The thrust and upper guide bearings of large vertical generators/motor are insulated from the frame to prevent circulating current from passing through the bearing. In addition, there is typically a shaft ground to reduce eddy currents which can cause pitting and damage to bearings. The bearing can be quickly damaged or destroyed if not adequately insulated. Test terminals usually are provided to check the insulation. Refer to FIST Volume 3-11, Generator Thrust Bearing Insulation and Oil Film Resistance for more information on bearing insulation testing.

Thrust bearings for large, vertical hydro generators/motors may be designed with or without a high-pressure oil lift system, or are modified to include one. Historically, large hydro generators/motors were made without high-pressure oil lift systems and performed successfully over time. As bearing technology increased and failures were observed, this method was developed to mitigate the operational scenarios where wear over time was most likely to occur. If outfitted on a generator/motor, it is likely a critical component to unit operations.

High-pressure oil lift systems inject bearing oil into the thrust bearing's load bearing surface (between thrust runner and shoe babbitt). This establishes an oil film between the clearance points prior to the start of unit rotation or during unit shutdown. This oil film protects the thrust runner from increased wear due to slow relative motion within an underdeveloped hydrodynamic oil film. Introducing oil pressure and flow to the bearing allows the bearing to act as a non-

contacting fluid film bearing at low speeds where oil film development is not consistent or insufficient. System designs can be of varying, but some common features include but are not limited to:

- Positive displacement oil pump
- Even flow to each segmented shoe bearing
- A check valve that resides in the bearing shoe and prevents hydrodynamic oil film pressure venting from the bearing shoe back to the hydraulic manifold when the high-pressure oil lift system is off.
- Contingency to ensure manifold oil pressure is not lost if one or more shoes vent more pressure over time as compared to when the system was commissioned.
- A dished portion of the bearing shoe babbitt designed to initially lift the thrust runner off of the bearing shoes when the unit is not rotating and not interfere with the development of the hydrodynamic oil development when the generator/motor is at 100% speed.

For more information about high-pressure oil lift systems and thrust bearings designs, reference the *Theory and Practice of Lubrication for Engineers*, by Dudley D. Fuller.

High-pressure oil lift systems are often included in the generator/motor start control circuit. There is usually a feedback sensor or device that indicates the system has operated and established an oil film. If these devices do not indicate the oil film has been established, it will not allow the unit to rotate which could cause bearing damage. The feedback sensors may vary but include manifold oil pressure sensors, manifold oil flow sensors, timers, or even displacement sensors. A qualified engineer should determine if start string permissive feedback setting changes are required if design changes have been made to the system to ensure proper operation.

2.11.2 Bearing Maintenance

Complete the following maintenance items on unit bearings.

[Inspect unit bearing lubrication system.]

1. Record and trend the bearing and oil temperatures.
2. Check and adjust lubricant level if out of range.
3. Record and trend flow and pressure of cooling water.
4. Record and trend pressure of bearing oil pumps.
5. Check oil flow in sight glasses (if applicable).

[Take an oil sample from all bearings and send to a suitable lab for analysis.]

1. Before a scheduled outage, while unit is running or within 30 minutes of shutdown, take oil samples from all bearings. If the bearing is equipped with online oil sensor monitoring, record data at this time to allow comparison later.
2. Ensure the sample is indicative of cycled oil by purging sample valve prior to collecting sample.
3. Send sample into a suitable laboratory for analysis.
4. Compare results to previous readings and determine if any corrective actions are required (e.g., filter, additive pack addition needed). Trend results to determine if bearing damage is occurring.
5. For bearings equipped with online oil sensor monitoring, compare sampled results to recorded results when the sample was taken. If the readings are inconsistent, calibrate or replace sensors.

[Filter unit bearing oil.]

1. When oil analysis results recommend oil filtration.
2. Filter oil if analysis testing was not performed.

[Check bearing clearances.]

1. Monitored - facilities which have a permanently installed vibration monitoring system (proximity probes):
 - a. Ensure shaft runout is being measured and recorded per the requirements in section 2.12.1); verify no abnormal shaft runout readings.
 - b. If bearing oil analysis results indicate no issues, no further actions are required.
2. Unmonitored - facilities which do not have a permanently installed vibration monitoring system (proximity probes):
 - a. Position the unit (this will be the same each time these checks are performed).
 - b. Use feeler gauges or dial indicators and “jacking” to determine bearing clearances.
 - i. Runout readings taken with temporarily installed proximity probes at each bearing may be substituted for bearing clearance readings if taken previously for the purposes of establishing trending data.

- c. Record readings then compare to previous readings and specified clearances.
 - i. Investigate any change in previous readings.

[Calibrate temperature sensors.]

1. Follow manufacturer's instruction when calibrating sensors.

[Calibrate oil level indicators.]

1. Follow manufacturer's instruction when calibrating level indicators.

[Check operation of lubrication system oil pumps.]

1. Ensure operation of alternating current (ac) and/or dc oil pumps for the guide bearing and thrust bearings.
2. Investigate any change from previous operating pressure readings.
3. Check filters on lubrication system.
 - a. Clean or replace filters as required.

[Check the generator thrust bearing and upper guide bearing insulation and oil film resistance test.]

1. If any oil system component has been disassembled or replaced (e.g., oil pump, piping, flexible hose(s), etc.), or after bearing reassembly perform this testing.
2. Refer to FIST 3-11, Generator Thrust Bearing Insulation and Oil Film Resistance.
3. Investigate the cause if insulation resistance is low relative to previous readings.

[Maintain bearing oil cooling coils.]

1. During an extended outage, remove cooling coils and clean out any solid deposits.
2. Hydrostatic test coils to check for leaks before reinstalling.

2.12 Shaft and Shaft Couplings

Shafts and shaft couplings connect the driver, such as a turbine or a motor, to the shaft of a driven machine, such as a generator or pump (photo 14). The shaft and shaft coupling are normally designed to runaway equipment speeds and when used in vertical units can also support the entire weight by the thrust bearing in the motor or generator. Rigid coupling designs are used and require precise alignment. Ridged coupling designs vary, but flanged and threaded couplings

are the most widely used. Flanged couplings are typically used on large units and consist of precisely machined flanges on each shaft, connected by a series of coupling fasteners around the perimeter of the flanges. The coupling fasteners are typically body-fit fasteners and are usually secure by tack welding after assembly. Threaded couplings, used to connect the line shafts of vertical turbine pumps and some small turbines, are cylindrically shaped with internal threads matching the external threads on the line shafts. The shafts to be coupled are simply screwed tightly into either end of the coupling.



Photo 14.—Shaft and coupling.

2.12.1 Shaft and Shaft Coupling Maintenance

Shafts and shaft couplings should require very little or no maintenance. The best way to maintain the shaft is to ensure vibration (shaft runout) is kept within tolerance by way of a proper shaft alignment (Section 2.12.2) and proper rotor balance, FIST Volume 2-2, Field Balancing Large Rotating Machinery. Vibration can be monitored by using a vibration monitoring and analysis system as discussed in Section 2.16. When a vibration monitoring and analysis system is not installed (unmonitored), manual checks need to be performed.

Complete the following maintenance items on the unit shaft and shaft coupling:

[Measure and record shaft runout.]

1. Monitored:
 - a. For systems that continuously record, trend, and alert abnormal shaft runout, verify the system is operating properly.
2. Unmonitored:
 - a. Check shaft runout with dial indicator or with proximity probes and data acquisition system:
 - i. Record and trend the runout as the unit is loaded from speed-no-load to full load. Make note of the maximum runout magnitude and the load at which it occurred. Investigate if runout is excessive or has changed significantly from previous readings.

2.12.2 Shaft Alignment

Misalignment is a common and sometimes serious problem. Poor alignment can cause premature wear or failure of bearings and in extreme cases, cracked or broken shafts. The procedure for alignment depends on the type of equipment and its design and is not expected to be performed on a routine basis.

Refer to the equipment manufacturer's instructions for specific directions for assembly and alignment. When manufacture instructions are not available, the procedure for aligning rotating machinery is discussed in detail in FIST Volume 2-1, Alignment of Rotating Machinery.

2.13 Generator/Motor Mechanical Components

While the generator/motor is normally considered an electrical component, it contains many mechanical elements. Mechanical generator/motor components include: the bearings and lubrication systems, bearing support, rotor spider and rim, stator frame, soleplates and anchors, air housing, ventilation and surface air coolers, brakes, and jacks.

2.13.1 Air Coolers and Cooling Coils

When converting kinetic energy into electrical energy, generators/motors produce heat energy from friction losses in the bearings and from conductor resistance within the stator windings. The heat energy must be removed to protect the stator windings, core, armature, and bearings from damage. Cooling the stator and rotor is critical to maintaining the rated and uniform operating temperatures corresponding to the thermal capabilities of the materials being used for construction and insulation. Often, smaller, older generators/motors use circulated ambient plant

air for cooling. Newer generators/motors usually have an enclosure or air housing and air-to-water heat exchangers, or air coolers, which use recirculated air through the stator and rotor (photo 15). Circulation through the generator/motor is often accomplished with a rotor or blades mounted to the rotor.



Photo 15.—Generator air cooler.

Generator/motor cooling is among the major uses of the cooling water system. Overcooling is avoided to prevent condensation from forming on the stator winding, especially when a generator/motor is shut down. Some units also have thermostatically controlled space heaters in the air housing to minimize the condensation forming on the windings. Automatic open/close valves are typically provided to control the flow of the cooling water to make sure the coolers remain full of water and the generator/motor maintains an even temperature.

Hydroelectric generators usually have thrust and guide bearings in an oil bath reservoir. Coolers (cooling coils) with or without extended spiral fins are installed in the oil bath to remove the heat generated by friction in the bearings (photo 16). Small air-cooled units frequently require cooling water for lubrication of the guide bearings.



Photo 16.—Cooling coil for turbine bearing.

2.13.2 Generator Brakes

Hydroelectric generators are equipped with a braking system to decelerate a rotating unit and resist rotation from wicket gate leakage. A common brake design uses brake shoes mounted on the lower bracket that operate against a rotor mounted brake ring (photo 17). Brake systems cause dust and create very high local temperatures. The dust can mix with oil droplets from the bearings to form adherent deposits that are quite flammable. Usually, unit braking occurs with a single continuous brake application until the unit is stopped. Intermittent brake application tends to increase the time required to stop the unit but may be necessary if excessive heating occurs.



Photo 17.—Brake shoe assembly.

2.13.3 Rotor

The spider/hub assembly is a large partially machined weldment or casting. Stresses can be significant as this component holds together a large, centrifugally loaded mass (the rotor rim). The major items to inspect are the spider arm-to-hub welds and balance weight welds.

The areas that usually require inspection include the rotor's center hub/spider arm assembly, stacked rotor rim, and pole/field winding assemblies and the welded locking keys that hold them together (photo 18).

Three major items associated with the rim assembly should be inspected: the rim-to-spider attachment key welds, the brake ring, and the tack welds on the rim-clamping studs. The rim-clamping studs are prevented from backing off by tack welds between the nut/washer and washer/rim top or bottom plate. Other areas to inspect are fan blade assemblies and other attachments. The brake ring is typically a large, flat, donut-shaped ring at the bottom of the rim.



Photo 18.—Rotor assembly.

2.13.4 Turning of Rotor

It is often necessary to manually turn the rotor of a large hydroelectric generator/motor for electrical testing, mechanical alignment, physical inspections, and for initial “rolling” of the machine after major repair work. When rolling the generator/motor after reassembly, workers continually push the rotor and listen for any generator/motor components rubbing or grinding. Most methods presently used to manually turn a generator/motor may not provide a means to quickly stop rotation. It is important to be able to stop rotor rotation to prevent injury to workers who must be present or near the turning rotor. Although no Reclamation workers have been injured by a turning generator/motor rotor, another utility has reported a death associated with the manual rotation of a generator/motor rotor. Other workers present were unable to stop the turning rotor in time to provide help.

Present methods available for manually turning a generator/motor rotor include pulling with a hoist or crane, turning by electrical means, pushing by hand, or using a specially designed rotor turning gear assembly.

Pulling the generator/motor rotor with a hoist or crane has limited value when continued rotation is desired, such as for initial rolling of the generator/motor. When turning a rotor by this method, one hook of the hoist or crane is attached to some structural component of the rotor. If a hoist is used, the other hook is attached to a stationary structural component of the generator/motor or powerplant. If the crane is used, the cable is threaded through a pulley that is attached to a stationary component. With the thrust bearing high-pressure oil lift system in operation, the hoist or crane is operated and the rotor can be turned a small amount until it coasts to a stop. The hoist or crane must then be re-extended, the hook repositioned, and the process repeated. At some facilities, two hoists are used in opposition to precisely control the position of the rotor.

An electrical turning method is also possible, although this method has been generally abandoned due to the complexity of the process and the amount of equipment required. This method involves exciting the field and one phase of the armature at a time with direct voltage.

The most convenient, but least safe method, is to push the rotor by hand. With the thrust bearing high-pressure oil lift system in operation, several workers brace themselves against some structural component of the generator/motor and push on the rotor with their feet. If enough workers push hard enough, the rotor will slowly begin to turn. To continue rotation, workers must continuously reposition their feet and push until the rotor approaches the desired position or until it has reached the desired speed. Once the rotor is in motion, its large momentum makes it virtually impossible to quickly stop the rotation manually.

While manually turning the rotor of a generator/motor by pushing the rotor with their feet, workers must take special care to maintain safe footing as the rotor is turning. To appreciate the difficulty involved, one must recognize that the top of the rotor has many bolts, nuts, and fan blades that can be used for gripping but must also be avoided when one is trying to readjust footing. Other areas of the rotor are smooth and, with the presence of only a small amount of oil, can be very slippery. The rotor should not be turned at a rate faster than convenient and safe for workers to maintain safe footing. Should a worker trip, slip, or otherwise become entangled with the rotating structure, that person could be pulled by the momentum of the turning rotor through the structure of the generator/motor and be seriously injured.

Workers other than those pushing the rotor are also at risk. The fatality previously mentioned occurred when the worker was picking some foreign material off the top of the rotor and his glove became entangled with a projection of the rotor.

To reduce the potential for injury, use of the generator brake to quickly stop the rotation of the rotor is recommended. The generator brake can be used for emergency safety situations or for accurately controlling the stopping position of the rotor. To use a generator brake, a person (radio operator) who can see all the activity in the generator air housing would be in radio contact with a person (brake operator) stationed at the manual brake lever to actuate the generator brakes. It has been found that the rotor will stop at essentially the same instant that the lever is moved. The only time delay would be the reaction and communication times of the

persons involved. The brake air and thrust bearing high pressure lubrication systems must be operational for this procedure to be used.

A deadman switch wired directly to the brake solenoid can eliminate some of the reaction time involved in communicating and reacting. The radio operator would hold the dead man switch so when the button is released, the solenoid would actuate the unit brakes.

Reclamation has designed a rotor turning gear mechanism that can be customized for each specific machine type and is installed directly below the brake ring (see figure 4 and photo 19). The mechanism has a support beam, a beam mounting arm, and a pneumatic cylinder. On the support beam are an adjustable speed electric motor, a gear reducer, and a rubber surfaced drive wheel. The beam mounting arm is permanently attached to a structural beam of the machine. The pneumatic cylinder is attached to a beam on the generator/motor and to the mechanism support beam by means of eye and pin brackets. The power and control signals for the adjustable speed motor come from a control box and connecting cable. The cable can be threaded through gaps in the machine stator so that the operator can view operations in the machine while controlling rotor movement.

When not in use, the mechanism rests on the machine air shroud (not shown in figure 4) directly below the brake ring. When the pneumatic cylinder is pressurized with plant air, the beam mounting arm pivots up slightly above the support beam and the rubber drive wheel is forced to press up on the lower surface of the brake ring (photo 19). When the adjustable speed motor is energized, shaft rotation is transferred through the gear reducer to rotate the rubber drive wheel. The rotation of the rubber drive wheel, in contact with the brake ring, applies a rotational force to the rotor. If the thrust bearing high pressure lubrication system is in operation to reduce bearing friction, the rotational force of the mechanism is sufficient to turn the rotor at a low speed.



Photo 19.—Rotor turning gear assembly.

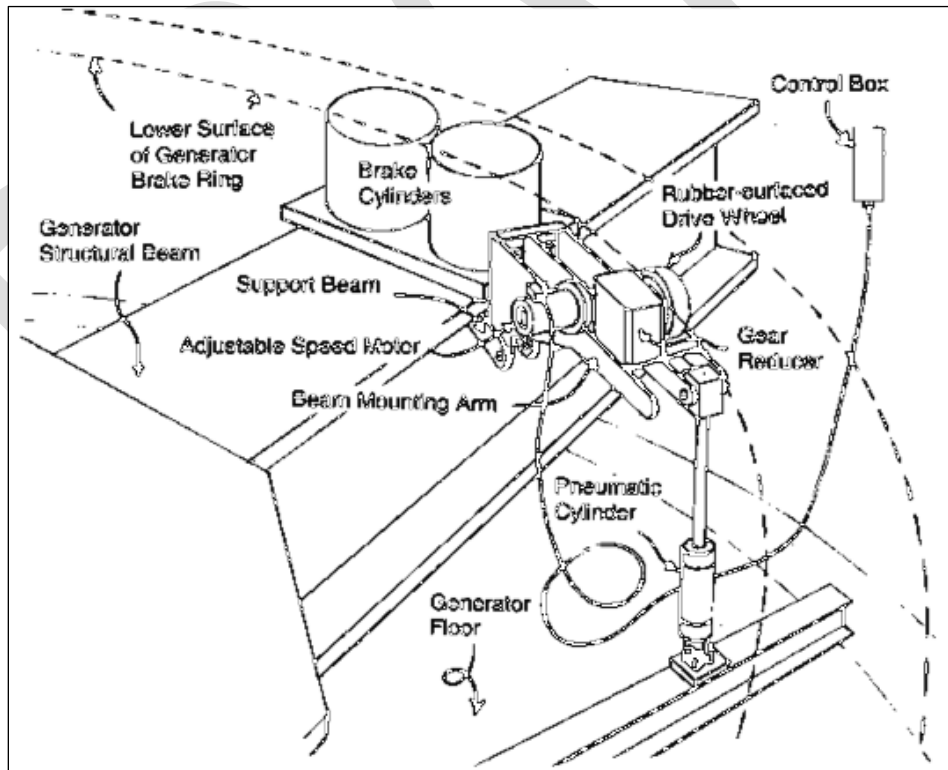


Figure 4.—Rotor turning gear mechanism.

The mechanism is designed to either remain in place during normal generator/motor operation or to be removed for storage or installation in a sister generator/motor. Installation involves attaching the turning gear assembly to the support beam and connecting the pneumatic cylinder to the support arm and to the beam on the generator/motor floor. The rotor turning gear is light enough so that two mechanics can attach it to the support beam in a few hours. When not in use, the mechanism drops safely out of the way of moving parts.

To operate the turning gear, set the adjustable speed motor speed control knob to the desired speed. Rotating the rubber wheel causes the generator/motor rotor rim to move at an adjustable rate from about 1 foot per minute to 9 feet per minute. In this range, speeds are fast enough for all maintenance, testing, inspection, and alignment operations yet slow enough to stop rotor movement before any problems develop. Rotation can be stopped within about one second, during which time the rotor rim moves about one inch.

2.13.5 Generator/Motor Mechanical Component Maintenance

Complete the following maintenance items on the respective mechanical component:

[Inspect the unit rotor.]

1. Check bolted connections for tightness and any evidence of movement.
2. Visually inspect stress carrying parts of rotor for cracks.
 - a. Pay particular attention to welds on the rotor spider. Any cracks should be evaluated by engineering personnel and a repair procedure should be developed.
 - b. If suspicion of a problem arises, further NDT testing should be completed.

[Inspect the unit stator.]

1. Check bolted connections for tightness and any evidence of movement.
2. Check stator frame for loose connections, cracks, or other damage.

[Maintain the unit air coolers.]

1. Flush sediment build-up.
2. Clean exterior surfaces of coils and check for leaks and damage.

[Check interior of air cooler coils for excessive scale buildup.]

1. When scale is excessive to cause cooling issues, clean mechanically or with an approved chemical treatment.

2. Perform a hydrostatic test after cleaning to check for leaks.

[Inspect brake components.]

1. Check condition of brake airline filters and lubricators.
2. If lubricator is not installed, operate unit jacks when the unit is offline to lubricate brake cylinders.

[Measure, record, and trend brake shoe thickness and check condition of the brake ring.]

1. Inspect brake shoes for overall thickness, uniform wear and debris buildup.
2. Operate brake cylinders to check for broken springs, locking devices, binding or sticking.
3. If no lubricators are installed, consider manually lubricating brake cylinders.
4. If brakes fail to operate smoothly, perform corrective maintenance to repair.

2.14 Oil and Lubricants

The primary purpose of a lubricant is to reduce friction and wear between two moving surfaces. A lubricant also acts as a coolant, prevents corrosion, and seals out dirt and other contaminants. For a lubricant to perform as intended, careful attention must be given to its selection and application as well as its condition while in use. FIST Volume 2-4, Lubrication of Powerplant Equipment, provides more information on lubricants and their use. The equipment manufacturer should provide specific information on the lubricant type and on the periodic recommended maintenance for a particular application.

2.15 Vibration Monitoring and Analysis

Vibration monitoring and analysis can be a useful part of a preventive or predictive maintenance program, and a variety of vibration monitoring systems are available. They use permanently mounted sensors to continually monitor vibration levels (shaft runout). The type of system used depends on the equipment being monitored. Potential benefits of a vibration monitoring system can include preventing damage, reducing outages, and reducing maintenance.

Proximity probe vibration monitoring systems are usually the best suited for hydroelectric units. Proximity probes measure the displacement of the shaft relative to a stationary component, such as the bearing housing.

[All facilities shall install and maintain vibration monitoring on all units.] The system must consist of proximity probes at each guide bearing elevation, with output data transmitted to a

system that is capable of alarming on peak-to-peak vibration levels. Exemption: Risk analysis determines that risk levels without the vibration monitors are acceptable. Maintenance of vibration monitoring systems shall be performed per Section 2.16.4.

2.15.1 Proximity Probe Systems

In a hydroelectric powerplant or a large pumping plant, proximity probes are used to measure the main shaft runout on the turbine/generator or pump/motor. A proximity probe is a non-contacting type sensor that provides a dc voltage directly proportional to the shaft's position relative to the probe. A typical proximity probe system uses two probes per guide bearing location, radially mounted and 90 degrees apart. The monitors for the probes are centrally located and are provided with relays for alarm (and sometimes shutdown function) with continuous indication of shaft runout in mils.

The optimum alarm and shutdown points will vary from unit to unit. The best way to set these points is experimentally. The runout amplitude should be measured from speed-no-load to full load, noting the normal amplitude of runout as well as the amplitude at any rough zones. If operation in the rough zone is not desirable, the alarm should be set high enough above normal amplitude to prevent nuisance alarms, but low enough to indicate when the unit is in the rough zone. If operation in the rough zone is allowed, the alarm point should be set above the maximum amplitude observed at any load. The shutdown point, if one is desired, should be set high enough to prevent nuisance tripping but low enough to prevent damage to the machine. A timer or deadband circuit may be required to avoid alarms as the unit passes through rough zones.

2.15.2 Accelerometer Systems

Accelerometers are lightweight vibration sensors that provide an electrical output proportional to the acceleration of the vibration of the machine being checked. Several accelerometer-based vibration monitoring systems are available, varying greatly in complexity and capability. Although accelerometers are available that can measure low frequency vibration (less than 5 hertz [Hz]), they are primarily used for higher frequency vibrations such as 1,800 revolutions per minute (rpm) electric motors. Accelerometers are generally ineffective for use on slow speed equipment such as hydroelectric units, since the primary frequencies are low and the critical measurement is displacement.

Depending on the system, accelerometers may be mounted permanently, handheld, or attached with a magnetic base. A common method of using accelerometers in a predictive maintenance program is to take periodic readings at different points on each machine. The data from these readings is usually stored in a portable recording instrument and downloaded to a computer. This data then must be analyzed and compared to previous readings to determine if there is a significant increase in the vibration levels, indicating an impending failure.

2.15.3 Signature Analysis

A common means of analyzing vibration data is through using a spectrum plot (figure 5). A spectrum plot is an X-Y plot where the X-axis represents the vibration frequency, usually in cycles per minute or cycles per second (Hz), and the Y-axis represents vibration amplitude in acceleration, velocity, or displacement units. A spectrum plot features amplitude spikes or peaks corresponding to operating frequencies of components of the equipment being tested. The initial plot provides a “signature” of the vibration for that particular piece of equipment. An increase in the amplitude of vibration at any of the various frequencies or the appearance of a new spike in subsequent plots may indicate an operational problem or impending failure.

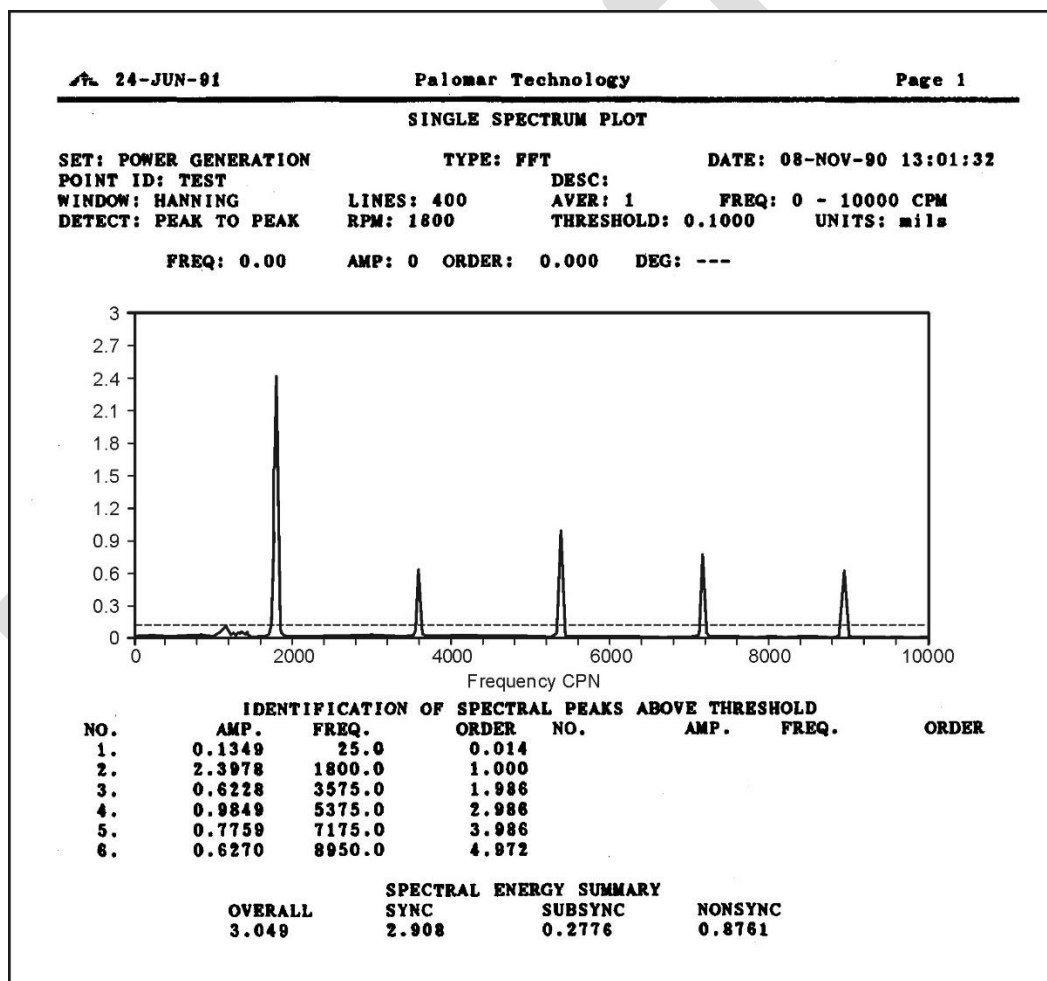


Figure 5.—Single spectrum plot.

A signature analysis program can be helpful in scheduling outages for bearing replacement on small motors and pumps. The amplitude of vibration at the bearing pass frequency will increase

as an antifriction bearing starts to fail. Signature analysis is also a good tool for hydroelectric units. Spectrum plots from proximity probes at each of the guide bearings can be used to diagnose problems such as misalignment, unbalance, or draft tube surging. To be effective with hydroelectric units, spectrum plots should be taken frequently since vibration levels will vary with the water level of the forebay and tailrace. Subsequent readings then can be compared to readings under the same operating conditions.

To perform a vibration analysis, a basic understanding of the characteristics of machine vibration and some knowledge of use of the test equipment is required. Training is available from many of the manufacturers of vibration monitoring systems.

2.15.4 Maintenance of Vibration Monitoring Systems

2.15.4.1 Maintenance of Proximity Probe Systems

To maintain proximity probe systems:

1. Visually inspect proximity probe heads for damage.
2. Visually inspect proximity probe cable leads and each power/communication driver for damage.
3. Verify proximity probes are adjusted to an appropriate stand-off distance from the shaft per manufacturers recommendations. This is to ensure the proximity probe does not come into physical contact with the unit shaft and also to ensure the proximity probe is operating in its designated linear measurement range.
4. Calibrate the system interface so that it properly displays the resting position of the unit shaft and the dynamic runout orbit plots.
5. Functionally test any alarm and trip points.
6. If a proximity probes output accuracy is in question, perform a test with a 0.003 inch feeler gauge held securely against the shaft, opposite of the subject proximity probe, and verify an approximate 0.003 inch readout on the system interface.

2.15.4.2 Maintenance of Accelerometer Systems

To maintain accelerometer systems:

1. Visually inspect accelerometer mounts for damage or looseness.
2. Visually inspect accelerometer cable leads and each power/communication driver for damage.

3. Calibrate the system interface so that it properly displays the vibration.
4. Functionally test any alarm and trip points.

DRAFT