



— BUREAU OF —
RECLAMATION

Facilities Instructions, Standards, and Techniques - Volume 2-6

Maintenance of Auxiliary Mechanical Equipment

REPORT DOCUMENTATION PAGE			Form Approved OMB No. 0704-0188		
Public reporting burden for this collection of information is estimated to average 1 hour per response, including the time for reviewing instructions, searching existing data sources, gathering and maintaining the data needed, and completing and reviewing this collection of information. Send comments regarding this burden estimate or any other aspect of this collection of information, including suggestions for reducing this burden to Department of Defense, Washington Headquarters Services, Directorate for Information Operations and Reports (0704-0188), 1215 Jefferson Davis Highway, Suite 1204, Arlington, VA 22202-4302. Respondents should be aware that notwithstanding any other provision of law, no person shall be subject to any penalty for failing to comply with a collection of information if it does not display a currently valid OMB control number. PLEASE DO NOT RETURN YOUR FORM TO THE ABOVE ADDRESS.					
T1. REPORT DATE (DD-MM-YYYY)T 01-08-2022		T2. REPORT TYPE Final		T3. DATES COVERED (From - To) Implementation Date: Upon publication.	
T4. TITLE AND SUBTITLE FIST Volume 2-6, Maintenance of Auxiliary Mechanical Equipment			5a. CONTRACT NUMBER		
			5b. GRANT NUMBER		
			5c. PROGRAM ELEMENT NUMBER		
6. AUTHOR(S) Technical Service Center Power Resources Office			5d. PROJECT NUMBER		
			5e. TASK NUMBER		
			5f. WORK UNIT NUMBER		
7. PERFORMING ORGANIZATION NAME(S) AND ADDRESS(ES) Power Resources Office, Bureau of Reclamation Denver Federal Center P.O. Box 25007 Denver CO 80225-0007			8. PERFORMING ORGANIZATION REPORT NUMBER FIST 2-6		
9. SPONSORING / MONITORING AGENCY NAME(S) AND ADDRESS(ES) Power Resources Office Bureau of Reclamation Mail Code 86-51000 PO Box 25007 Denver CO 80225-0007			10. SPONSOR/MONITOR'S ACRONYM(S) PRO		
			11. SPONSOR/MONITOR'S REPORT NUMBER(S)		
12. DISTRIBUTION / AVAILABILITY STATEMENT Available from the National Technical Information Service, Operations Division, 5285 Port Royal Road, Springfield, Virginia 22161					
13. SUPPLEMENTARY NOTES					
14. ABSTRACT The Bureau of Reclamation operates and maintains 53 hydroelectric powerplants and many switchyards, pumping plants, dams, canals, and associated facilities that are important to electric power and water delivery systems. This document establishes consistent procedures for maintenance of auxiliary equipment within our facilities.					
15. SUBJECT TERMS					
16. SECURITY CLASSIFICATION OF:			17. LIMITATION OF ABSTRACT UL	18. NUMBER OF PAGES 57	19a. NAME OF RESPONSIBLE PERSON Power Resources Office
a. REPORT UL	b. ABSTRACT UL	c. THIS PAGE UL			19b. TELEPHONE NUMBER (include area code) (303) 445-2922

SS Standard Form 298 (Rev. 8/98)
P Prescribed by ANSI Std. Z39-18

(FIST 020) 08/01/2022
NEW RELEASE

Facilities Instructions, Standards, and Techniques - Volume 2-6

Maintenance of Auxiliary Mechanical Equipment

Prepared by

**Power Resources Office
Technical Service Center**

U.S. Department of the Interior
Bureau of Reclamation
Power Resources Office
Denver, Colorado

(FIST 020) 08/01/2022
NEW RELEASE

Mission Statements

The U.S. Department of the Interior protects and manages the Nation's natural resources and cultural heritage; provides scientific and other information about those resources; and honors its trust responsibilities or special commitments to American Indians, Alaska Natives, and affiliated Island Communities.

The mission of the Bureau of Reclamation is to manage, develop, and protect water and related resources in an environmentally and economically sound manner in the interest of the American public.

Disclaimer

This written material consists of general information for internal use only by Bureau of Reclamation operations and maintenance staff. Information contained in this document regarding commercial products or firms may not be used for advertising or promotional purposes and is not to be construed as an endorsement or depreciation of any product or firm by the Bureau of Reclamation.

Table of Contents

	Page
Codes and Standards	vi
Reclamation Standards and Documents	vi
Reclamation Forms	vi
References	vi
Acronyms and Abbreviations	vii
Symbols	vii
1.0 Introduction	1
1.1 Purpose and Scope	1
1.2 Reclamation Standard Practices	1
1.3 Maintenance Tables.....	2
1.4 Manufacturer Recommendations.....	2
1.5 FIST Revision Requests	2
2.0 Auxiliary Piping Systems	3
2.1 General.....	3
2.2 Gravity Drainage Systems.....	4
2.3 Unwatering Systems	5
2.4 Unit Cooling Water Systems	8
2.5 Service-Water Systems.....	12
2.6 Domestic Water and Sanitary Waste Systems	13
2.7 Oil Systems.....	16
2.8 Compressed Air Systems	20
2.8.1 Service Air Systems	20
2.8.2 Brake Air Systems.....	21
2.8.3 Governor/Discharge Valve Systems	21
2.8.4 Water Depression Air Systems.....	22
2.9 Valves for Auxiliary Piping Systems.....	23
2.9.1 General.....	23
2.9.2 Gate Valves.....	23
2.9.3 Globe Valves, Angle Valves and Needle Valves	24
2.9.4 Butterfly Valves.....	25
2.9.5 Ball and Plug Valves	26
2.9.6 Check Valves	28
2.9.7 Pressure-Relief and Safety Valves	28
2.9.8 Pressure-Reducing Valves	29
2.9.9 Valve Operators	30
2.10 Instrumentation.....	31
2.10.1 General.....	31
2.10.2 Pressure Gauges.....	31
2.10.3 Thermometers.....	31
2.10.4 Rate-of-Flow Gauges.....	31
2.10.5 Pressure Switches	31
2.10.6 Elapsed-Time Meters.....	32
2.10.7 Liquid Level and Sight Flow Gauges	32

2.11	Maintenance of Auxiliary Piping Systems	32
3.0	Air Compressors	34
3.1	General.....	34
3.2	Reciprocating Air Compressors	34
3.3	Rotary Screw Air Compressors	36
3.4	Air Compressor Accessories	38
3.4.1	Inlet Filters.....	38
3.4.2	Intercoolers and Aftercoolers.....	38
3.4.3	Separators	38
3.4.4	Traps.....	38
3.4.5	Dryers.....	39
3.4.6	Pressure-Regulating Valves	39
3.4.7	Receiver Tanks (Pressure Vessels), Gauges and Pressure Relief Valves.....	39
3.4.8	Unloader Valves.....	39
3.5	Maintenance for All Types of Air Compressors	39
3.6	Maintenance for Reciprocating Compressors	40
3.7	Maintenance for Rotary Screw Compressors	41
4.0	Heating, Ventilating, and Air-Conditioning (HVAC) Systems.....	42
4.1	Maintenance of HVAC Systems	42
5.0	Engine Generator Sets	43
5.1	Maintenance of Engine Generator Sets.....	44
6.0	Mechanical Drawings	46

Figures

	Page
Figure 1. Gate valve components.....	24
Figure 2. Globe valve components.	25
Figure 3. Butterfly valve components.....	26
Figure 4. Ball valve components.....	27
Figure 5. Plug valve components.....	27
Figure 6. Check valve components.	28
Figure 7. Pressure relief safety valve components.	29
Figure 8. Pressure reducing valve components.	30
Figure 9. Simple compressed air system.	34
Figure 10. Two-stage reciprocating compressor.	36
Figure 11. Cutaway view of a twin-screw reciprocating compressor.	37

Photographs

	Page
Photograph 1. Plant sump oil skimmer assembly.....	5
Photograph 2. Sump pumping unit discharge assembly.	6
Photograph 3. Float operated sump-water-level monitoring and indicating systems.	7
Photograph 4. Unit cooling water pump assembly.	8
Photograph 5. Automatic, self-cleaning, moto-operated strainer and associated piping components.	9
Photograph 6. Manual basket duplex strainer.	10
Photograph 7. Service-water hydropneumatic tank.	13
Photograph 8. Pneumatic duplex sewage ejectors.	15
Photograph 9. Sewage pumping units and collection reservoir tank.	15
Photograph 10. Portable oil purifier equipment.	17
Photograph 11. Construction of the oil transfer system piping assembly.	18
Photograph 12. Brake air receiver tank.....	21
Photograph 13. Reciprocating type air compressors.	35
Photograph 14. Rotary screw type air compressor.....	37
Photograph 15. Engine generator set and fuel supply tank.....	43

Codes and Standards

Code of Federal Regulations

40 CFR Chapter 1 Subchapter D Part 112, *Oil Pollution Prevention*

National Fire Protection Association

NFPA 110, *Standard for Emergency and Standby Power Systems*, 2022

Reclamation Standards and Documents

- FAC 01-04 *Review of Operation and Maintenance Program Examination of Associated Facilities (Facilities Other Than High- and Significant-Hazard Potential Dams)*
- FAC 01-07 *Review/Examination Program for High and Significant Hazard Dams*
- FAC 04-01 *Power Review of Operation and Maintenance (PRO&M) Program*
- FAC 04-14 *Power Facilities Technical Documents*
- FIST 2-4 *Lubrication of Powerplant Equipment*
- FIST 2-9 *Inspection of Unfired Pressure Vessels*
- FIST 4-1A *Maintenance Schedules for Mechanical Equipment*
- FIST 4-1B *Maintenance Schedules for Electrical Equipment*
- FIST 4-5 *Corrosion Protection*
- FIST 5-2 *Fire Protection*
- RCD 03-03 *Request for Deviation from a Reclamation Manual Requirement and Approval or Disapproval of the Request Operation and Maintenance, Equipment and Procedures, Release No. 19, Dated 1957*
- RSHS *Reclamation Safety and Health Standards*

Reclamation Forms

POM: <https://teamssp.bor.doi.net/printanddup/forms/POM%20Forms/Forms/AllItems.aspx>

POM-226, FIST Revision Request

POM-300, FIST Variance Form

POM-400, Engine Generator Operation and Testing Log

References

T. Wireman, *World Class Maintenance Management*, Industrial Press Inc., 1990.

Acronyms and Abbreviations

cfm	cubic feet per minute
EPSS	Emergency Power Supply System
FAC	Project Planning and Facility Operations, Maintenance, and Rehabilitation (of the Reclamation Manual)
FIST	Facilities Instructions, Standards, and Techniques
HDPE	High Density Polyethylene
HVAC	Heating, Ventilating and Air-Conditioning
ISO	International Standards Organization
NFPA	National Fire Protection Association
O&M	Operation and Maintenance
PCB	Polychlorinated Biphenyls
PRO	Power Resources Office
psi	pounds per square inch
PVC	Polyvinyl Chloride
RCD	Records Management (of the Reclamation Manual)
Reclamation	Bureau of Reclamation
RM D&S	Reclamation Manual Directive and Standard
RSHS	Reclamation Safety and Health Standards
SCADA	Supervisory Control and Data Acquisition
SOP	Standard Operating Procedure
SPCC	Spill Prevention Control and Countermeasures
TSC	Technical Services Center

Symbols

%	percent
°F	degrees Fahrenheit

This page intentionally left blank.

1.0 Introduction

The Bureau of Reclamation operates and maintains hydroelectric powerplants, switchyards, pumping plants, water delivery equipment and associated facilities in the 17 western United States. These facilities house complex electrical and mechanical equipment that must be kept operational because they are critical to the electric power and water delivery systems relied on by many. Facilities Instructions, Standards, and Techniques are technical documents that provide criteria and procedures that should be utilized by the offices involved in managing Reclamation facilities and assets.

This document establishes standard technical practices to ensure the safe, reliable, economical, and efficient O&M of Federal facilities by keeping related assets in good condition and ultimately protecting Federal investments. These technical practices provide a sufficient level of detail to ensure consistent application while providing flexibility for the use of innovative techniques and approaches. This document was developed with input from staff in Reclamation's Denver, regional, and area offices.

1.1 Purpose and Scope

This document is intended to promote uniformity in the manner that assets are managed, documented, and coordinated, and may be utilized by transferred facilities and other entities as appropriate. It establishes consistent procedures, minimum standards and O&M criteria for hydroelectric equipment and systems owned and operated by Reclamation. Other technical documents may provide additional electrical and mechanical maintenance information for the equipment or systems discussed in this document.

O&M requirements are based on industry standards and experience. Maintenance requirements vary based on equipment condition and past performance, and sound engineering practices and maintenance management should be employed for special circumstances. Manufacturer recommendations and instructions should be consulted for additional maintenance that may be required beyond what is stated in this manual.

This volume includes standards, practices, procedures, and advice on day-to-day operation, maintenance, and testing of mechanical equipment in Reclamation facilities.

1.2 Reclamation Standard Practices

FIST manuals are designed to provide guidance for maintenance and testing on equipment in Reclamation's facilities. There may be multiple ways to accomplish tasks outlined in this document. Facilities may exercise discretion as to how to accomplish certain tasks based on equipment configurations and available resources.

Maintenance of Auxiliary Mechanical Equipment

Reclamation's regions, PRO, and TSC agree that certain practices are required to be consistent across all Reclamation facilities. Mandatory FIST procedures, practices, and schedules that appear in **{Red, bold, and bracketed}** or **[Black, bold, and bracketed]** text are considered Reclamation requirements for the O&M of equipment in power facilities. RM D&S FAC 04-14, *Power Facilities Technical Documents*, describes the responsibilities required by text designations: **{Red, bold, and bracketed}**, **[Black, bold, and bracketed]**, and plain text, within this technical document. Refer to RM D&S FAC 04-14 for more details concerning technical documents.

1.3 Maintenance Tables

Maintenance tables for tasks described in this document are included in FIST 4-1A, *Maintenance Scheduling for Mechanical Equipment*, and FIST 4-1B, *Maintenance Scheduling for Electrical Equipment*.

1.4 Manufacturer Recommendations

The information in this document is based on manufacturers' documentation and historic Reclamation practices. Due to the differences in equipment designs, owner's manuals and manufacturer's recommended maintenance should be consulted when developing job plans. Not following the manufacturer's guidance may void the warranty of new equipment. If there is a discrepancy between the FIST and the manufacturer's recommendations, the job plan must use the more stringent practice unless there is a reason that a less restrictive maintenance practice is warranted. Use of a less restrictive maintenance practice must be approved as outlined in RM D&S FAC 04-14 by either a deviation or a variance. A deviation may be granted in accordance with RCD 03-03 and variances are approved in accordance with FAC 04-14 using POM Form 300.

1.5 FIST Revision Requests

The FIST Revision Request Form, POM-226, is used to request changes to a FIST document. The request will include a summary of the recommended changes and a basis for the revision or new FIST. These forms will be submitted to the Manager, PRO. The PRO Manager will keep a list of Revision Requests for each FIST and include these in the next scheduled revision unless the change is prioritized sooner.

2.0 Auxiliary Piping Systems

2.1 General

Auxiliary piping systems typically refers to the sub-system piping that support the critical function(s) of a larger, more complex system or assembly. It typically conveys water, oil, or air either under atmospheric conditions or under pressure in water delivery and power generation applications. This includes the piping, valves, and instrumentation on gravity drainage and unwatering systems, unit cooling water systems, service-water systems, domestic water and sanitary waste systems, oil systems, compressed air systems. The materials used for these systems include, but are not limited to, cast iron, steel pipes, copper tubing, galvanized piping, HDPE piping, PVC piping, and rubber hoses. The material choice for the piping system is based on what best suits the fluid, the construction of the system, and the environment in which it is installed.

Note that all pipe that supplies a fire system is considered part of a fire system. See FIST 5-2, *Fire Protection*, for specific requirements for fire protection systems.

The design of these systems depends on their intended use. The pertinent factors within the system design include but are not limited to flow rate, operating pressure, fluid type (compressible or non-compressible), fluid friction factors, thermal expansion, and maintainability. This type of information will yield performance requirements for pumps, motors, valves, fittings, piping, etc. It is also valuable in maintenance for when repairs are necessary. Those same parameters determine a baseline of an in-kind part replacement, not including material properties of the component(s). Any upgrades must meet or exceed the system operating parameters and design intent.

Attention must be paid to the construction materials used within a piping system such that galvanic corrosion is not induced and is instead mitigated. The ease of maintenance in the design phase of a system considers concepts like system isolation, part location, part accessibility, the control of energy with the system, the ability to disable parts of the system without affecting critical systems, the ability to quickly disassemble components, and using commercial-off-the-shelf parts with up to date construction standards.

Piping systems require maintenance over time to extend their useful life and ensure reliable function. Be aware of the failure modes that your subject piping system can experience and develop your maintenance program on that along with manufacturer recommendations of components within the piping system. Follow maintenance procedures pertinent to the fluid being transferred and the construction of the piping system.

Monitor the condition of piping systems to reduce unscheduled outages due to piping failures. The first indication of a large-scale systemic problem may be a leak, or the failure of system component like a valve. Although a leak or valve failure may just be an isolated event, it may be an indication of the condition of the entire system. Determining the internal condition of water piping can be difficult. Partial disassembly of a piping system can provide a good indication of the condition of the entire system. It may also introduce local damage due to degradation of piping connections over

Maintenance of Auxiliary Mechanical Equipment

time. Nondestructive tests, such as radiographs or ultrasonic tests, can be used to determine the condition of a piping system. Radiographs not only show pipe wall thickness but also the amount of scale buildup inside the pipe.

The most common water piping failure is a result of corrosion over time. The life of water piping systems depends greatly on the pipe material properties, and the corrosion promoting properties of the water it carries. A best practice is to select system materials with a similar valence-electron property within the Galvanic Series of Metals to minimize galvanic corrosion between adjacent parts, see FIST 4-5, *Corrosion Protection*. For exterior corrosion of piping systems, a protective coatings program may be required to mitigate exterior corrosion as a primary means of system failure. Corrosion and joints and fittings may be problematic. Ensure leaks through joints are quickly repaired or replace the parts that make up the joint to refresh the connection with new uncorroded surfaces.

Service air systems may also suffer corrosion damage because of internal condensation build-up over time. Scale and rust particles can damage pneumatic tools and cause pneumatic cylinders to stick. If moisture in air piping is a problem, a moisture separator should be installed where best suited. Moisture collection and drainage should be designed for the system. Purging collected water from air piping should be part of a preventative maintenance program for that system.

Oil piping systems typically require little maintenance other than repair of an occasional leak, routine oil testing, and filtering. Continue to inspect oil systems to assess the system reliability and potential functional performance decrease resulting from a leak or faulty component within the system. Oil pumps still need regular maintenance of bearings, seals, and pumping components. If an oil pump fails, then it is correct to assume particles or shavings of the failed parts will flow throughout the piping system. Oil testing and analysis help detect early onset of these moving component failures. The goal of these tests and inspections is to allow for enough time to address repair or replacement of the failing component(s) in a scheduled effort rather than in an emergency scenario.

If a piping system fails prematurely because of corrosion, in rare instances it may be acceptable to replace piping with a nonmetallic material. Specific usage of nonmetallic piping needs to be verified with any applicable codes and careful consideration should be taken regarding the temperature, pressure (strength), and durability limitations of the material. The installation instructions for nonmetallic piping should be followed carefully. Nonmetallic piping should not be used in compressed air systems.

2.2 Gravity Drainage Systems

A gravity drainage system drains wastewater open to atmospheric pressure to the facility sump. Drainage water is pumped by the Unwatering System to a location outside of the facility; in a powerplant these locations are either the tailbay or forebay reservoirs. This system typically includes floor drains, equipment drains, and other drains which have intermittent discharge.

Since the wastewater does not contain sanitary waste or sewage, the gravity drainage system floor drains are not equipped with traps. Only the sanitary waste system plumbing drains must be

provided with a trap. The wastewater that is collected by the gravity drainage system collection piping is not pressurized, but instead flows by gravity. Floor drains with hinged or removable grates are typically provided for easy access to the drainage piping during cleanout activities.

The drainage system near tools, equipment, and oil storage reservoirs may collect oil from accidental leakage, spill or rupture. Before the water in the sump is pumped out of the plant, the oil must be separated from the water to avoid contaminating the tailbay. This is normally accomplished by allowing the oil-water mixture to settle out within the sump over time, followed by removal with an oil skimmer or equivalent piece of equipment (Photograph 1). Oil removed from a sump is collected within a reservoir, like a 55-gallon drum, and periodically disposed of using best practices.



Photograph 1. Plant sump oil skimmer assembly.

2.3 Unwatering Systems

The unwatering system (Photograph 2) is a pressurized piping system for draining the waterway of a turbine or a pump impeller. Components in the turbine waterway include a spiral case, draft tube, and penstock. Components in a pump waterway include a spiral case, suction tube, and discharge line. The primary means of unwatering is draining by gravity to the powerplant sump and allowing air ventilation within the waterways so that there is never a risk of pipeline failure due to internal vacuum pressure. The powerplant sump is pumped out by dedicated high-capacity sump pumps. Their discharge piping has both embedded and exposed piping, valves, and instrumentation.

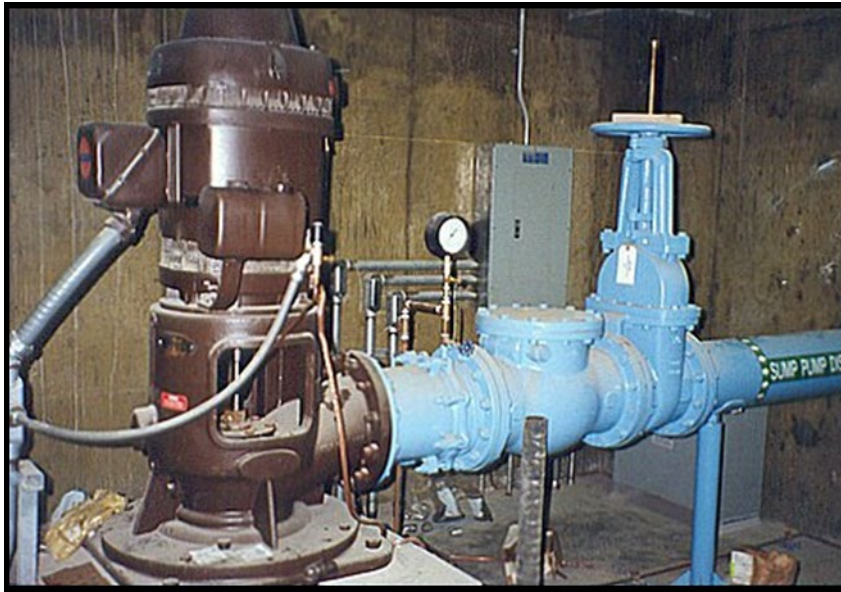

Photograph 2. Sump pumping unit discharge assembly.

Sump Pumps — A common configuration of powerplant sump pumps are two high-capacity vertical turbine-type pumps. They are likely automatically operated by a series of floats that identify a minimum water level, a high-water level “pump on”, and a high-water level alarm. The two sump pumps are typically operated over the range of sump levels on a lead/lag basis with an alternator that changes the lead pump every start. The sump water inflows come from the drainage system and the unwatering of the main unit turbine/pump casing, casing extension, draft/suction tube, and penstock/discharge line. The sump water is usually discharged to the tailbay.

There are a few key design features in the discharge line of the sump evacuation pumps. It should include a check valve, an air vacuum vent valve, and an isolation valve. The check valve should be located downstream of the pump close to pump elevation to prevent water backflow from the tailbay back into the sump. An air vacuum vent valve should be installed upstream of the check valve on the discharge line to prevent water column separation during pump shut down. An isolation valve in the discharge line is necessary for pump replacement and repair of piping on the interior of the powerplant. The location of the valve may be placed right at the wall of the embedded pipe to reduce the amount of exposed pipe in the event of pipe failure. The discharge line exterior to the powerplant is typically located below the low-tailbay level to prevent splashing and to thwart waterfowl and vermin from building nests in the outlet of the discharge pipe.

Sump Drainage Pump — In addition to the two main sump pumps, a manually operated jet-type sump drainage pump is common to completely unwater the sump when required for maintenance activities, such as removing sediment from the floor of the sump. Some facilities have also used scavenging eductors for completely unwatering the sump for maintenance purposes.

Sump Water-Level Indication — A sump water-level indication system (Photograph 3) is used to control pumps, alarm, and trip equipment based on the water level within the sump. This system will operate the two sump pumps in a lead/lag configuration to accommodate different inflow rates to

the sump. It is used to annunciate a high-sump water-level alarm and pumping status. It may also be configured as protection to shut off the generators under high-water emergency conditions. The monitoring system usually consists of a float-operated or electronic probe unit water-level assembly located two floors above the sump, adjacent to the sump pump motors. It is common to see the water level-indication devices installed with physical barriers, such as vented pipes or screens, that reduce fouling by sump debris and calm wave action. Mechanical floats may be protected within an enclosure that prevents debris from contacting the float. Inflows and pumps can induce currents and wave action that can give false indication or make pump switches chatter on and off. Measuring calm water keeps the elevation signal stable. A float on a rotary encoder will typically reside within a vented pipe that submerges all the way down to the bottom of the sump. If debris gets inside of the pipe, then it can pin the float in place and give a false sense of lower water level increasing the risk of powerplant lower floor flooding. These sensor guide pipes can be made from metal, plastic, or fiberglass as long as the function and material properties are suited for their intended installation purpose.



Photograph 3. Float operated sump-water-level monitoring and indicating systems.

The sump pumps are not to pump under low submergence conditions. A low water-level indicator and pump control switch will be set at an elevation to prevent damage to the pumps in that scenario. The pump manufacturer will define pump operating parameters. If that information does not exist, then a good rule of thumb is to keep the pump intake fully submerged during operation such that it does not draw in air.

The elevation level of the sump is reported by the water-level indicating systems through SCADA. An example of this system is a 4 to 20-milliamp output electronic water-level pressure sensor

installed in the sump and a digital display system panel meter either in a control room or at a control panel.

2.4 Unit Cooling Water Systems

Unit cooling water systems (Photograph 4) is a pumped raw water system that provides water for cooling the unit stator and unit auxiliaries in a hydro powerplant. The equipment included in a unit cooling water system includes, but is not limited to, stator air cooler heat exchangers, the shaft bearing sump oil coolers, turbine/pump shaft packing or mechanical seals, turbine/pump wearing rings, and air compressors. Thermal control of the equipment ensures long life and reliable operation of the unit and its auxiliaries.



Photograph 4. Unit cooling water pump assembly.

The cooling water flow requirements for these various unit components are determined by the equipment manufacturers to include the unit, the turbine/pump, and their auxiliaries. Seasonal source water temperatures will affect the equipment operating temperatures but will not likely have a negative impact when all else is normal and the equipment is regularly maintained.

The system design depends on whether the source water comes from the forebay or tailbay. Water from the forebay usually has sufficient pressure and volume for all cooling water needs. Supply water pressure may need to be regulated to a lower operating pressure to match downstream equipment specifications or to reduce the life cycle cost of the downstream systems. Water sourced from the tailbay will require pumps to deliver water to match unit cooling water flow and pressure requirements. Regardless of the source water location, the supply piping is equipped with a strainer and distribution piping. This can be isolated to deliver water in various ways to prioritize generation reliability through shared cooling water intake and piping configuration options. Note that other facility water supply needs, like fire water and service water, may be sourced from the same intake location as the unit cooling water systems.

The main cooling water-supply strainer should be sized to accommodate the range of flow required by its downstream equipment. The design parameters include, but are not limited to, the range of minimum and maximum flow rates, upstream supply pressure, required downstream supply pressure, range of incoming debris size, and downstream particulate size straining requirement. The main cooling water-supply is typically a manual duplex basket type strainer or an automatic, motor-operated, self-cleaning backwash strainer. The type typically depends on the anticipated frequency of cleaning and whether plant personnel will be available to perform maintenance duties on a regular basis (Photographs 5 and 6). Silt or other abrasive material is usually present in varying degrees in reservoir or river water, at least seasonally. Typical main cooling water strainer basket perforation requirements are from 1/32-inch to 1/8-inch.



Photograph 5. Automatic, self-cleaning, moto-operated strainer and associated piping components.

Those unit components requiring water with a finer degree of filtration, such as pressure-reducing valves, turbine mechanical seals, packing boxes, or small tube/port heat exchangers may require additional filtration equipment such as a centrifugal separator, bag filter, sand filter or a similar system. Typical mechanical seal filtration requirements are 25 microns. Water lubricated turbine bearings commonly run raw water, but it may be good practice to require finer particulate filtration for extended service life (reduced particulate wear) of the bearing staves and journal. HVAC heat exchangers are good examples of this but are not usually counted within a unit cooling water system. An alternate supply of water, such as a potable water system, can also be used for components requiring finer filtration.

The manufacturer of the unit components can supply the specific filtration requirements to be provided. In lieu of a manufacturer's filtration recommendation, a qualified engineer must review the system components and determine an acceptable particle size allowed through the most stringent component. Note that filters may be only for specific equipment like a packing box or mechanical seal. Unnecessarily finer mesh strainers, which require frequent cleaning, should be avoided to ensure that proper flow is supplied to the equipment. Multiple strainers configured in a

Maintenance of Auxiliary Mechanical Equipment

parallel arrangement may also be provided where necessary to maintain continuous flow during maintenance cleaning operations.



Photograph 6. Manual basket duplex strainer.

The cooling capacity of the cooling water system is determined by the equipment it services. The equipment manufacturers will provide operating criteria required for function and reliability of the equipment. The unit air coolers and bearing oil sump coolers are susceptible to changing environmental air and water temperatures. Operational alarms and trip settings must be set from functional testing and system commissioning procedures. However, operating temperatures may change over time, and it is imperative that any operational changes from design parameters are reviewed and approved by qualified personnel. In the case of an off design operational parameter, a qualified engineer should review operating data and whether the new system operating parameters are acceptable to employ for normal operation. Risks of total and subsystem failure must be considered in this analysis.

Cooling water may also be needed for the unit transformers. These water/oil heat exchangers are typically a double-tubed design. Water pressure in the transformer water/oil heat exchangers is less than the oil pressure to prevent water from entering the transformer oil under minor leakage conditions. Since the unit power transformers are normally located on the exterior of the plant, the cooling water system must be protected where freezing conditions can occur when the transformer is not energized.

Cooling water piping should have an isolation valve located as far upstream as possible within the powerplant such as at the penstock, spiral case, or tailbay water supply piping. This valve is the first

line of defense if the water supply must be isolated. This valve may have high differential pressures across the valve and are sometimes equipped with both a motor operator and manual operator. If the valve is elevated out of the reach of a plant operator, it may be equipped with remote operation such as a push button station and a manual operating device such as a chain.

Throttling valves are typically provided on the water discharge of each unit air cooler, turbine bearing oil cooler, and turbine packing box to balance the water flow and pressures through their distribution piping. This allows for temperature control among the various heat exchangers and ensures that the cooling water is properly distributed. Valves for control of flow are always provided on the discharge of a cooler to provide the required back pressure to ensure the filling of all water passages.

Air or vacuum valves are typically included on air cooler inlet piping to support filling and draining operations. The valve should be located at the high point to the piping system. Care should be taken to ensure nuisance discharge from the valve does not drip on sensitive equipment.

Flow rates within the cooling water system may need to be regulated either because of critical functions or to balance flow distribution. Flowmeters are used to ensure that critical equipment get the necessary volume flow rates they require for optimum performance. Flow switches may be used to alarm or trip a unit based on low flow scenarios that will result in significant damage. Packing box flow switches are typically set up to provide unit protection/unit start permissive (interlock) to ensure that the packing box will not overheat. A failed packing box can result in excess water within the turbine pit and potential flooding. A thermometer is also commonly installed on the discharge of each cooler branch to verify proper operating temperatures.

A pumped cooling-water supply requires a standby supply so that if a pump is out of service the unit can still be operated. This can be provided by having two pumps per unit, each of which can supply a unit's cooling water requirement, or one pump per unit consisting of a common discharge header to all units and fed by one main pump plus one or more backup pumps in the system. Other arrangements to provide backup pump capacity may also be acceptable depending upon the particular circumstances. An isolation valve is typically installed on the suction and discharge of the pumping unit for use during maintenance activities, and a check valve or an air-operated valve in the discharge piping is used to prevent backflow through the pumping unit when it is not operating.

All cooling water systems are provided with means for limiting the pressure, such as a pressure-relief valve, when there is a possibility of subjecting the heat-exchange coolers to a pressure in excess of the design pressure. Avoid running water pipes over machinery or electrical equipment which would be damaged by condensate or leakage. The piping may be insulated to prevent condensation.

Some generator air-coolers are equipped with "tell-tale" drains which terminate outside of the air housing for the purpose of checking for air-cooler leakage. These drains can become blocked by debris or insects which would prevent the detection of leakage.

Since unit-cooling water systems are conducive to the growth of organisms such as zebra or quagga mussels, it should be determined whether a biological control program should be implemented for the unit cooling water system.

2.5 Service-Water Systems

Service-water systems supply water for general usage within the facility through a series of hard piped outlets. Service-water piping includes process and support equipment to move or filter water to meet downstream needs. This typically includes strainers, filters, pumps, hydropneumatic tanks, flow meters, hose outlets, throttling valves, isolation valves, and bypass piping. The construction of this system within the facility should be configured for reasonable maintenance and operational configuration.

In a hydroelectric powerplant, the service water is usually drawn from the forebay. Since the service water is typically raw, untreated water, it can be supplied from the same raw water that supplies the fire suppression and unit cooling water systems. The raw water supply strainer is either manual cleaning or automatic cleaning filter depending on the facility needs. Duplex basket strainers are common on older systems that are not automated. Automatic, self-cleaning strainers are useful for high debris inflow and reduced personnel-required maintenance. If supply water pressure is too low for the end process or equipment, then it may be necessary to add a booster pump to ensure sufficient pressure and flow are directed to the appropriate equipment. This may require throttling valves to balance the system flows. Service-water hose outlets typically require an outlet pressure of at least 65 psi or enough to supply sufficient flow at the outlet location of highest elevation.

Service water piping selection depends on the system operating pressures, flow rates, water quality, water salinity, and maintainability. For permanent facilities a material's ruggedness to exterior impacts and long-term corrosion should be prioritized. Ensure that galvanic corrosion is considered when pairing dissimilar metals and that there is an appropriate use of dielectric coupling and hardware isolation. Corrosion protection of steel pipe is critical for long-term reliable service. Ensure that pipe exteriors are properly coated to reduce corrosion due to humidity or condensation over time. If condensation is common and causes a maintenance issue, then consider applying thermal berries or coatings to reduce pipe sweat (condensation formation) on the pipes. Provisions for freeze protection should be made where required.

A hydropneumatic tank is used to keep constant pressure in the service water system and allows for reasonable, intermittent pump operation unless the service water demand is significant (Photograph 7). The purpose of these tanks in a service water system installation is to reduce the number of pump starts, to passively maintain system pressure, to buffer system pressure spikes, and allow for a minimum pump run time to ensure that, when the pump does start, it runs long enough to reach normal operating conditions (power, temperature, lubricity, etc.). The tank can be of the commercially available pre-charged rubber bladder type or can be fabricated to the capacity specified and pressurized with air from a connection to the compressed air system.



Photograph 7. Service-water hydropneumatic tank.

The capacity of the tank should be sized so that the pump motor does not start so frequently as to cause overheating from repetitive inrush current scenarios. The limit in the number of starts per hour depends upon the motor horsepower and speed. Some sump pumps or well pumps require flow around the inline motor casing to provide cooling, so a minimum run time per pump is also desired when sizing a hydropneumatic tank for a given pump. Refer to the pump motor manufacturer's specifications for duty cycle and maximum start cycles per hour.

Where the source water is contaminated or where local laws require, the supply should be treated per the State Health Department regulations before delivery to any service-water hose outlet or lawn sprinkler system.

The outlets should be spaced to allow delivery of water to all needed plant locations using available hose lengths. Typically, quick disconnect hose connections are used at the service water outlets. If hose water shows signs of corrosion, then it may be time to perform pipe inspections and system replacement to reestablish non-corrosion conditions within the wetted pipe.

2.6 Domestic Water and Sanitary Waste Systems

The domestic water system supplies water for drinking fountains, lavatory basins, janitor's floor sinks, and toilets independent of any other facility water system. Cooling water for air compressors may also come from the domestic supply because of the cleanliness and low flow requirements.

Reclamation facilities are often in a remote location where the powerplant domestic water supply cannot be connected to a municipal water source. In those cases, the domestic water has traditionally been taken from an adjacent reservoir or river, passed through a sand-type filter or other suitable filter, and chemically treated within the facility. Many Reclamation plants still use this type of disinfection of the plant potable water supply; however, some facilities use municipal water

Maintenance of Auxiliary Mechanical Equipment

supplies for domestic water because of their supplier's regular infrastructure maintenance and stringent industry standard water treatment guidelines. Many plants now use commercially available bottled water for drinking purposes. Domestic water piping is typically of copper tube materials due to its corrosion-resistant properties and ease of installation. Plumbing products used for potable water are held to a different manufacturing standard than industrial piping, so repair or replacement parts when maintaining a potable water system should focus on any specifications unique to potable water use.

It is important to provide a sufficient number of isolation valves in the plumbing system to provide operational flexibility in system configuration management. These valves enable various areas to be isolated for maintenance purposes without requiring the whole system to be taken out of service. Bypass piping paired with isolation valves may provide benefits to keeping systems online while allowing routine maintenance activities to take place.

The plant sanitary waste plumbing system typically utilizes hub-and-spigot cast iron soil pipe for the embedded sanitary waste piping, and hub-and-spigot or no-hub cast iron soil pipe for the exposed sanitary waste piping. Where exposed waste and vent piping is not subject to exterior exposure, damage, or excessive temperatures, plastic piping has been used. While the gravity drainage system can use floor drains without traps, all floor drains in the sanitary waste system should use traps to prevent sewer gas from entering the plant.

Since the multiple floors of power and pumping plants are traditionally located below grade, the sewage collected from the plumbing fixtures must be lifted to ground level for disposal outside the plant. It is therefore helpful that restroom and other plumbing fixtures be located in a central location of the service bay from which the gravity flow sewage piping can be collected and routed to a lower floor in the plant. The sewage drainage piping can either be emptied into sewage ejectors or into a sewage pump collection reservoir tank.

Sewage ejector equipment is automatically operated by electrodes in the receivers which allow pressurized air from the compressed air system to force sewage accumulated in the receivers from the plant (Photograph 8). Pneumatic sewage ejector assemblies typically consist of two duplex receivers that will allow one receiver to discharge its sewage, while the other receiver is receiving sewage flow from the sanitary waste system. The amount of sewage ejector static and friction head discharge lift is limited by the pressure of the plant's compressed air system.

Please refer to the RSHS document for details not covered in this section.



Photograph 8. Pneumatic duplex sewage ejectors.

Non-clog-type sewage pumps are typically used where high lifts are required to remove sewage from the plant (Photograph 9). They are also provided in parallel with one primary pump and one pump to serve as a backup in the event of primary pump failure. Each pump should be capable of handling rated system inflow. If it is desired that the pumps be operated an equal amount of time, an alternator can be installed to switch the primary pump every time the pumps are needed to discharge sewage.



Photograph 9. Sewage pumping units and collection reservoir tank.

2.7 Oil Systems

Reference FIST 2-4, *Lubrication of Powerplant Equipment*, for additional information on lubricants not contained within this document. There are two types of bulk oil used within powerplants: turbine oil and transformer oil. These systems are plumbed from an oil processing room to either storage facilities, their equipment for filling and draining, or to the service/erection bay connections for adding more oil to the system or evacuating it from the facility. It is common to have on-site oil filtration so that oil can be filtered and reused on a periodic maintenance cycle.

Turbine oil is used for generator and turbine guide bearing lubrication and cooling. A common type of turbine oil is ISO 68 for large vertical hydro generators. The turbine oil can also be used for governor equipment oil, although a governor may require different fluid properties and therefore need a different oil type. Using the same type of oil for guide bearings and governors simplifies maintenance and storage practices. Critical properties for an oil include viscosity, additive package, particulate count, and acid number. An effective oil testing program can monitor all these properties. This testing will provide preventative maintenance information regarding failing parts as evidenced by high particulate counts in the oil.

Transformer oil is used for electrical insulation and cooling. Transformer oil cleanliness and moisture control are essential. Most large transformers are pressurized just above atmospheric pressure with a nitrogen blanket (inert gas pocket). This positive pressure helps ensure that the transformer does not introduce outside air with humidity into the transformer body. The temperature swing of a large transformer when online and offline is large enough to have significant oil and gas expansion and contraction within the transformer body. It is crucial that large transformers are sealed well with respect to retaining their oil and gas for optimum long-term operation.

Each type of oil system often has its own complete system of clean oil storage tanks, dirty oil storage tanks, transfer pumps, oil filtration, and supply and return piping. Turbine oil often has accumulator tanks (hydropneumatic tanks) and oil sumps within auxiliary equipment. Both piping systems should be equipped with valves and piping necessary to transfer oil, purify the oil, and service the equipment unique to the type of oil. This piping system design reduces the likelihood that turbine oil and transformer oil mix, which would result in potentially catastrophic performance issues with unit bearings, unit hydraulic control, or transformer insulating properties. Separate piping systems are not required for disposal of the oil.

The oil purifier should be designed to handle all types of oil, and the routing valves in the transfer lines should be identified to prevent mixing of the different types of oil (Photograph 10). The direction of flow should be clearly marked for each position of the routing valves. In smaller plants, these routing valves may be replaced by valved hose connectors, permitting the oil purifier or oil transfer pump to be connected to either system as desired by changing hose connections.



Photograph 10. Portable oil purifier equipment.

All oil handling and storage devices should be covered under the facility's SPCC plan. Inspections should verify that all necessary equipment, containment features, and clean-up required by the SPCC plan are available and in good operational condition.

There may be an advantage to servicing and replacing transformer oil at powerplants via contractor. A main driver for this is the past storage and regulation of PCBs within transformer oil and the low frequency of their bulk replacement. If the facility authorities prefer this method of transformer oil maintenance, then they must change the facility business practices. The unused transformer oil storage devices and the associated transfer oil piping and filtering equipment can be removed from the plant.

The oil storage room is typically located on a lower floor of the powerplant so that the oil-return piping in the plant can flow by gravity to the oil storage tanks. The floor of the oil storage room should be outfitted with the ability to contain the stored oil within the room in the event of a tank rupture and loss of stored oil; this may be in the form of a recessed floor. If there is no way to contain the oil, a curb should be built in front of all oil storage components to contain the volume of all oil stored in the room, including the volume of oil in the associated piping. There should be ample space in the room for all equipment, including the oil purifier, oil filter, transfer pumps, storage tanks and piping system.

A fire-suppression system is typically provided for the oil storage room. There are several types available such as automatic (fusible link) sprinkler systems, deluge sprinkler systems, fire suppressant foam, clean agent, and water mist system. The oil storage room should be outfitted with an automatically closing fire-rated door(s) for all openings to the room. Chilling drains may be necessary for all drainage locations within the oil room to reduce the risk of burning oil draining to the sump.

Maintenance of Auxiliary Mechanical Equipment

Oil Storage Tanks — Each filtered and unfiltered transformer oil storage tank should hold a minimum of 110 percent of the oil capacity of the largest plant transformer. The filtered and unfiltered lubricating oil storage tanks should be designed to hold a minimum of 110 percent of the oil capacity of the governor oil system and all bearings of the largest unit. Circuit-breaker oil storage tanks, if required, should hold sufficient oil to fill the largest breaker. Each tank should have an overflow pipe the same size as the incoming pipe. The overflow pipe for a filtered tank should discharge into the corresponding unfiltered tank. In the event of an overflow or spill into the facility sump, every reasonable effort should be made to provide adequate containment. 40 CFR Part 112.7 lists the requirements for SPCC Plans.

Transfer Pumps — The oil-transfer pumps are normally of the positive displacement rotary gear type and are provided with a safety relief valve (Photograph 11). Normally, an oil-transfer pump is configured to pump to an open atmosphere container like a storage tank or bearing sump. These pumps should be rated for a continuous duty cycle for use during long duration filtration or large transfer volumes. These systems are typically manned so that they do not run without pumping oil.



Photograph 11. Construction of the oil transfer system piping assembly.

Waste Oil Pumps — A pump is provided to pump waste oil from the oil storage tanks to the plant deck waste valve for removal by a tank truck. These may sometimes be the same as the oil transfer pumps used when servicing equipment or filtering oil.

Oil-Return Pump — An oil-return pump may be required to pump oil from the turbine bearing or governor sump to the gravity-flow oil-return piping if these components are lower than the gravity-flow oil-return piping. The location of this pump is normally in the turbine pit.

Hoses — Portable flexible hoses are often used in the oil storage and purifying room to connect various pieces of equipment and storage tanks; however, a permanently installed fixed piping system without hoses provides for cleaner operation and reduces the chance of the oil piping becoming contaminated. If contamination is a concern, then consider purging pipes and or hoses with a slug of

oil intended to be transferred to reduce the potential amount of volumetric mixing of different oils. Oil compatibility tests can be performed to determine the expectations of two oils mixing in varying volumetric percentages.

Oil-Return Piping — The oil-return piping is used to drain oil from the transformers, unit guide bearings, and governor sump to their specific unfiltered storage tanks. The oil-return piping from the unit bearings also carries the overflow from the bearing reservoir(s) in the event that reservoir is overfilled. The oil-return piping typically operates by gravity and terminates at the unfiltered oil storage tank. For anything lower in elevation that doesn't allow for gravity feed, an oil-return pump must be used. As an aid in maintenance and cleaning, all piping should be drainable to a storage tank, reservoir, or a sump. All pipeline bypasses required to facilitate such drainage should be provided.

Filter — The purpose of a filter is to remove suspended contaminants in an oil system to ensure that all equipment oil quality needs and specifications are met. Filters can keep oil clean from gradual particulate accumulation over time, or they can be the first line of defense if there is device failure resulting in in-flow debris from damaged parts finding their way to more critical, harder to replace equipment. The location of a filter must ensure that it is protecting critical equipment, that it does not put an undue burden on the performance of the system, and that it is maintainable.

The design and selection of a filter should include the following parameters: flow capacity, pressure drop for a given flow, particulate filtration rate, and maintainability. A filter's flow capacity should be equal to that of the lubricating oil-transfer pump for the necessary filtration rate. The filter should not present an unacceptable pressure drop when clean and it should not plug with debris faster than can be maintained or replaced. The particulate filtration rate depends on the equipment that it protects. The type and configuration of the filter should best fit the facility maintenance program. The filter should have replaceable, disposable cartridge-type elements with a filtration (micron) size recommended by the unit manufacturer.

Valves — The use of each valve of the oil handling system should be readily apparent upon inspection. The primary purpose of valves is for piping configuration management and energy isolation. Different styles of valves are used for different functions within configuration management. A properly specified valve accounts for galvanic corrosion of dissimilar metals, the connection type to the adjacent pipes, the normal working pressure, it is intended use (throttling, isolation, manual control, automatic control, etc.), and the maintenance it requires over time.

A flushing connection should be provided at the end of each supply line and connected through a bypass to the oil-return line. A globe valve should be provided in the flushing connection and should only be opened when flushing the lines. At all other times it must remain closed. A check valve should be provided in the bypass piping connection to prevent dirty oil from entering the clean oil supply piping.

Oil Sampling — Sampling valves may be installed at all locations where oil quality checks are required. Oil sampling procedures are critical to ensure that the proper oil quality sampled is representative of what is going through the equipment. For example, a unit bearing oil sump circulates oil. The appropriate type of oil in the system to sample is the circulating oil that makes its way to the journal interface with the bearing shoes. The oil sample location must pull from that

Maintenance of Auxiliary Mechanical Equipment

circulating location and not the bottom of the oil sump or drain because it may have more sediment and not reflect the true health of the oil system. The placement of oil sampling inlets should be within the circulating flow and should not interfere with equipment function. It is not always practical to have optimum sampling locations, so if a drain is used to sample oil then ensure that the oil system is at normal operating conditions (temperature, flow rates, etc.) and be sure to purge the sample piping/tubing of stagnant oil that may not be representative of the desired oil sample. The typical locations include the lower points of tanks, reservoirs, ends of supply lines, supply and return lines of the purifier, and low points of the transformers.

Governor Sump Fill Line — The governor sump oil filling line should discharge into the strainer basket of the governor sump and should be controlled by a valve within the cabinet. Small governor systems may be filled by other means such as directly from an oil storage container.

2.8 Compressed Air Systems

The compressed air systems in a powerplant can be broken down into the following types of systems:

- Service air systems
- Brake air systems
- Governor air systems
- Water Depression (Condense Mode) air systems

A powerplant requires a constant supply of compressed air. Air is needed for facility maintenance, unit braking, equipment control, pressurization of the governor or discharge valve operating system, draft tube water level depressing (a.k.a. Condense Mode Operations), turbine rough zone mitigation, and other plant functions. The air for each of the systems is typically stored in separate compressed air storage tanks when there are different working pressures required, different volume flow rates required, or when operating critical components.

Powerplant compressors are machines designed for compressing air from an initial intake pressure to a higher discharge pressure. Single-stage compressors are those in which compression from initial to final pressure is complete in a single step or stage. Two-stage compressors are those in which compression from initial to final pressure is completed in two or more distinct steps or stages. Air compressors are discussed in detail in later in this document.

2.8.1 Service Air Systems

The service air system typically operates at a nominal 100-psi and provides air for maintenance and control systems. Maintenance activities include utilizing pneumatic tools within the facility as needed. It is also used for system control of a variety of plant equipment and devices such as control air for valving operations, sewage ejectors, pressurization of a hydropneumatic tank, and supply air for an ice-bubbler system.

The compressor capacity can vary by plant size and the air-supply functions required. Typically, two air-cooled compressors with automatic start/stop and manual control features maintain the service air receiver at normal pressure. The two compressors are typically furnished with lead/lag control

and with the ability to alternate the lead compressor by the use of pressure switches located on the air receiver tanks.

Typically, service air is distributed throughout the entire plant so that personnel working on all floors have access to it. Service air connections with quick-disconnect hose connections and 50 feet of hose are usually located next to each fire-hose reel for use by plant maintenance personnel.

These service air systems may accumulate condensation over time, so purging pipes maybe required prior to use through tools or equipment, and on a periodic basis.

2.8.2 Brake Air Systems

The unit brakes are supplied by an independent compressed-air distribution system complete with receiver (Photograph 12). The air-brake receiver is supplied with compressed air from the service air system through a check valve to ensure that adequate pressure and quantity of air for braking is maintained regardless of the variation of pressure in the service air system. The receiver is sized to have sufficient volume to supply the air required for one complete stop of one generating unit in a plant of four units or less and proportioned to the same ratio in larger plants.



Photograph 12. Brake air receiver tank.

2.8.3 Governor/Discharge Valve Systems

A Governor/Discharge Valve operates on higher pressures than typical service air pressures. A smaller air-cooled compressor with a capacity between 350 to 1000 psi, depending on the facility needs, is used for this service. It is expected that the air-over-oil pressure tank (a.k.a. hydropneumatic tank and accumulator tank) will have to be recharged with compressed air

Maintenance of Auxiliary Mechanical Equipment

occasionally to maintain the necessary stored energy air cushion. Air can be lost through pressure leaks within their system connections, but some may be lost as dissolved air within the oil during operation.

An appropriately sized air compressor should have the ability to sufficiently charge the oil pressure tank in a reasonable time for its intended operations and maintenance. Some tanks use a combination of air pressure and pumped oil to achieve final tank pressure. Filling a governor accumulator tank, for example, may be a combination of filling the tank with compressed air and pumping oil to reach the normal operating pressure. The end goal is to have the accumulator tank oil level within the normal operating range. Some systems utilize pre-charged sealed nitrogen containers in lieu of a compressed air system for operating a governor or discharge valve operating system. With either an air or nitrogen system, there should be enough energy in the system to fully stroke the governor wicket gates or the discharge valve open or close 2½ times.

2.8.4 Water Depression Air Systems

Where the tailbay elevation is normally above the elevation of the turbine runner, compressed air is also used for depressing (pushing down) water in the draft tube for generator synchronous condense (motoring) operation. This reduces the drag friction on the turbine runner while it is motoring so that it does not need to consume as much power to maintain speed. Two methods for controlling the elevation of draft tube water elevation during condense mode is generator power output data or directly monitoring the draft tube elevation via floats or pressure sensors. Although there are many ways to design a control system to establish a bubble in the draft tube for condense mode operations, designs should primarily consider the reliability of the feedback and the failure modes of the total air admission system (i.e., air compressor duty cycle, heat dissipation of a rapidly compressed gas, float system control signal chatter, vibration of the turbine runner, energy consumption with and without water contacting the turbine runner, etc.).

There are several methods for initiating a bubble below the turbine runner for condense mode operations. Typically, separate large-capacity air compressors and receivers are used to provide a large volume of air to depress the water level in the draft tube quickly. The tailbay pressure is the backpressure that this air system must oppose. Therefore, the amount of air is a function of the supplied pressure expanding to tailbay pressure and displacing a known volume of water. Air will leak out of the draft tube through the tailbay over time due to wave action in the draft tube capturing bubbles.

These air compressors are typically water-cooled rotary screw compressors and have a nominal pressure of 100 psi with capacities from 250 to 500 cfm depending on the volume of the turbine. The receivers are typically interconnected to the service air system so that minor leakage from the system will be replenished with the smaller service air compressors. This avoids starting the large-capacity water depressing compressors for a short amount of time in order to bring the system back up to the required pressure.

Some facilities also use high-volume, low-pressure blowers to supplement their compressor systems. An example of high-volume, low-pressure blower use is to mitigate turbine runner and draft tube rough zones. When distributed to the right location, the compressible gas in the draft tube will reduce or eliminate the creation of water vapor bubbles at vacuum and is observed to significantly reduce turbine vibration and draft tube pressure pulsations during a rough zone. A “rough zone” is

considered to be a range of generator operation that is of concern and requires additional operational knowledge as to whether damage is occurring to components within the system, or that the likelihood of unit failure is increased and is unacceptable.

During depressing operations, the system receivers will be drawn down to a very low pressure, and sufficient compressor capacity should be provided to recover normal pressure in a reasonable amount of time. The compressors should normally be under automatic start-and-stop control, starting when the pressure drops below a prescribed minimum, and stopping when the maximum pressure in the water-level depressing system is obtained. The amount of air delivered to depress the water level within a draft tube is tuned during system commissioning. The opening time of an automated valve that admits depression system air will be regulated and adjusted to ensure that: (1) enough air is admitted to get water off of the turbine runner, (2) too much air is not admitted and sent out to the tailbay, and (3) the time between depression air bursts is sufficient for the duty cycle of the air compressor and recharging its pressure tank. Once a bubble is established, the high-volume low-pressure blowers may be used to extend the time between high-pressure bursts.

2.9 Valves for Auxiliary Piping Systems

2.9.1 General

The suitability of a valve for a particular service is decided by its materials of construction in relation to the conveyed fluid or gas as well as its mechanical design. The valves described below are available in a variety of corrosion-resistant materials depending on the particular fluid or gas and pressure rating required. The interior of these valves can also be furnished coated or with a lining material to resist deterioration. The size of these valves is determined by the size of the end connections which connect to the piping system or equipment.

2.9.2 Gate Valves

The main purpose of gate valves is to start and stop flow. In operation, these valves are primarily either fully open or completely closed. When fully open, the fluid or gas flows through the valve with very little resistance and, as a result, there is very little pressure or friction loss through the valve.

Gate valves should not be used in the regulation or throttling of flow for a number of reasons. High flow velocities in partially opened gate valves may cause cavitation and erosion damage to the valve leaf disk and seating surfaces. There may also be material deformation due to vibration and chattering of the disc.

Gate valves consist of three major components, as shown in Figure 1. These are the body, the bonnet, and the trim of the valve. The body of the valve is usually connected to the piping system by means of flanged, threaded, or welded connections. The bonnet consists of the moving, operating parts of the valve, and it is connected to the body usually with bolts to permit disassembly for cleaning and maintenance. The valve trim includes such components as the stem, the gate leaf wedge or disk, and the seat rings.

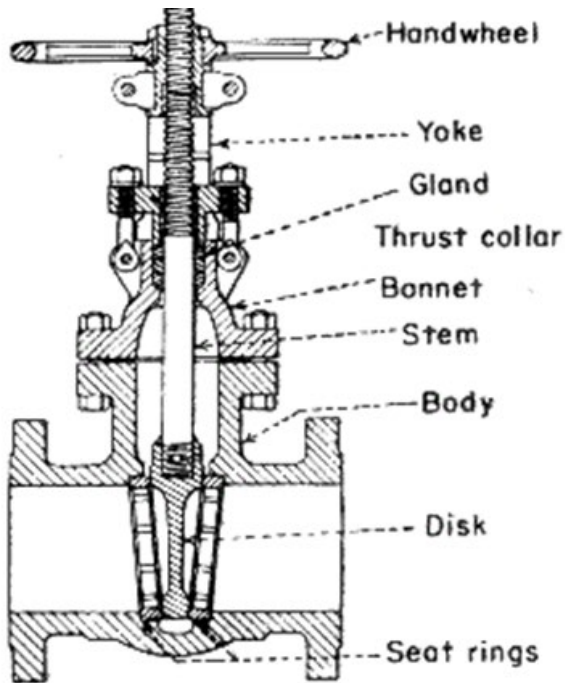

Figure 1. Gate valve components.

There are two basic types of gate valves:

- The wedge type, in which a tapered wedge is forced on both sides against the valve seats when the valve is closed.
- The double disk type, in which the disks are forced against a set of parallel valve seats by a wedging mechanism as the stem is tightened.

Gate valves can be furnished with a rising or non-rising stem. In a rising stem valve, the operating stem threads are not in direct contact with the fluid or gas, and the stem rises through the handwheel. The operating stem threads are in contact with the fluid or gas in a non-rising stem valve. With non-rising stem valves, the handwheel and stem are in the same position whether the valve is open or closed. These valves are convenient where space is limited.

Rising stem valves should be used wherever possible, since plant personnel can tell whether the valve is open or closed just by looking at the position of the valve stem. Larger rising stem type gate valves are furnished in an outside screw and yoke configuration.

2.9.3 Globe Valves, Angle Valves and Needle Valves

Globe valves are primarily used in applications where throttling for the control of flow is required and where tight shutoff is necessary. Due to the internal configuration of the valve, pressure or friction loss of flow is higher through a globe valve than through a gate valve.

Globe valve components are shown in Figure 2. The disks and seats are generally easily replaceable. Due to the opening and closing action of the valve, the shorter disk travel offers a time advantage for open and closing.

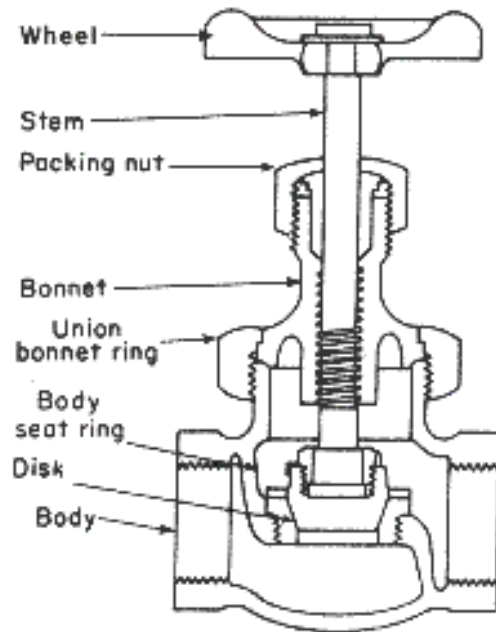

Figure 2. Globe valve components.

The principal variations in globe valves are the different types of disks employed. Plug-type disks have a long-tapered shape that provides maximum resistance to the erosive action of the fluid stream. Composition disks have a flat face that is pressed against the valve seat like a cap. Foreign material that might score or prevent tight closure of metal-to-metal seated valves does not normally affect the tight closure of composition disks. A variety of different materials are available for composition disks to serve a wide range of applications. Valves can be changed from one application to another by simply changing out the material of the composition disk.

Globe valves usually have a rising stem configuration and the larger sizes, just like gate valves, have an outside screw and yoke configuration.

A variation of the globe valve is the angle valve. The components and configuration of an angle valve are the same as those of a globe valve except that the inlet and outlet are at 90 degrees to each other.

A needle valve is similar in configuration to a globe valve except that the end of the stem is needle-pointed. These are traditionally small valves that are used for instrument and gauge applications. Very accurate throttling can be achieved with needle valves, and they are extensively used in applications involving high pressures and temperatures.

2.9.4 Butterfly Valves

Butterfly valves are primarily designed for the starting and stopping of flow. Even though they are not primarily designed for the throttling of flow, they have been used for this purpose. Since the

Maintenance of Auxiliary Mechanical Equipment

valve leaf is in the fluid stream, they often have to be held in their operating position, since the configuration of the leaf tends to open or close the valve when fluid passes over it.

The major components of a butterfly valve are the body and the disk leaf, as shown in Figure 3. These shutoff valves are capable of being bubble-tight and can be furnished with resilient or metal seats, depending on the application for which the valve is used. Body and disk leaf materials can be fabricated from a variety of corrosion-resistant materials. Even though the leaf is in the flow stream, they are considered low-head-loss valves since they have a low differential pressure loss. Butterfly valves can be operated quickly, as they require only a quarter turn to open or close.

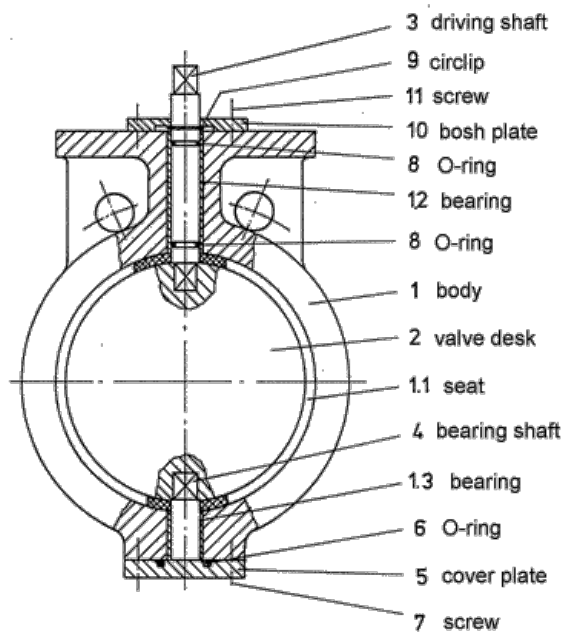

Figure 3. Butterfly valve components.

Butterfly valves can be installed in piping systems by flange-end connections and also in a wafer-type configuration between two flanges.

2.9.5 Ball and Plug Valves

Ball and plug valves are primarily designed for the starting and stopping of flow. In operation, these valves are primarily either fully open or completely closed. They are not designed for the regulation of flow, although they have been used in some applications for gas flow throttling. When these valves are fully open, the fluid or gas flows through them with very little resistance and, as a result, there is very little pressure or friction loss. Since these valves operate from fully open to fully closed with only a quarter of a turn, they are capable of quick operation. These valves are easy to repair and usually do not need to be removed from the pipeline; hence, maintenance costs are low.

Ball Valves. — The major components of a ball valve are the body, the spherical ball plug, and the seats (Figure 4). They are made in three general configurations: full port, reduced port, and venturi port. The full port valve has an inside diameter equal to the inside diameter of the pipe. The reduced

port usually is one pipe size smaller than the line size. The venturi port has a constricted port with higher velocities and subsequent higher pressure losses through the valve.

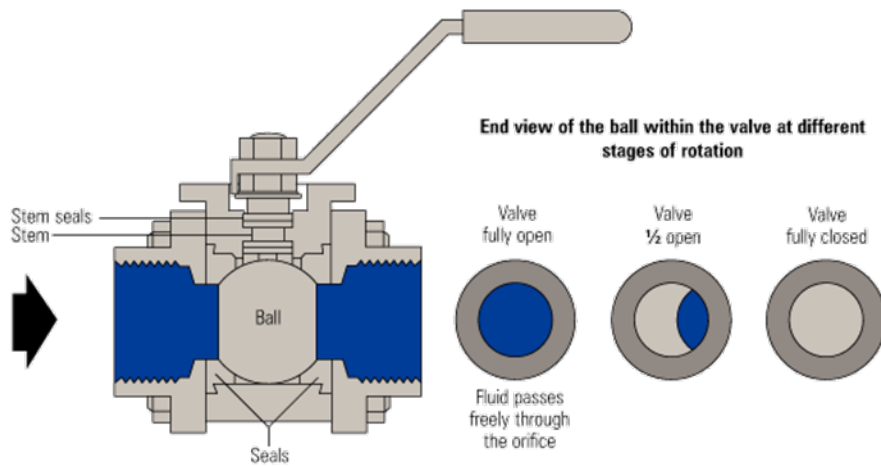

Figure 4. Ball valve components.

Plug Valves. — The major components of a plug valve are the body and the tapered plug (Figure 5). Maximum flow efficiency is obtained when the opened tapered plug faces in the direction of flow. Plug valves provide bubble-tight closure when the plug is rotated a quarter turn from fully open. The hole or port in the tapered plug is generally rectangular, but these type valves are also available with a round port design. Major plug valve patterns or types are identified as regular, venturi, short, round port, and multi-port. Plug valves can be furnished with or without lubrication. The lubricant seal type valves are less subject to seizing or wear and may exhibit somewhat greater resistance to corrosion in some service environments.

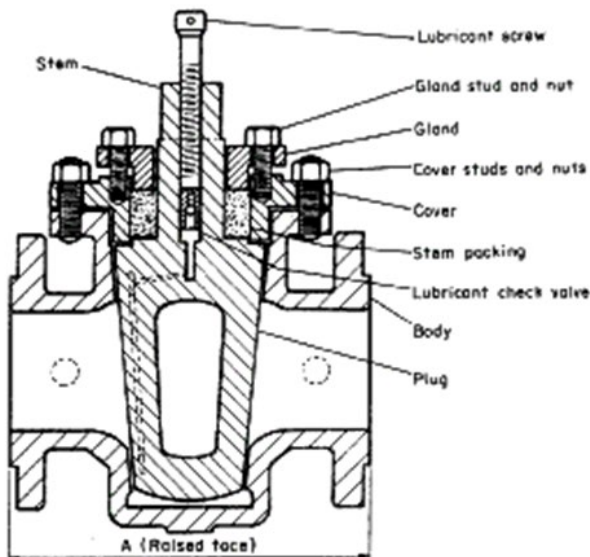

Figure 5. Plug valve components.

2.9.6 Check Valves

Check valves (Figure 6) are used to prevent backflow in piping systems, and are designed in various configurations, including swing checks, lift checks, ball checks, piston checks, and poppet check valves. The force of gravity plays an obvious part in the functioning of a check valve, and the position of the valve must always be given consideration. Swing checks are the most commonly used type, and they must be located in the piping system so that the flapper will always close freely and positively by gravity. Caution must be exercised when using swing-type check valves in systems where frequent and rapid flow reversals can take place. If the flapper is allowed to slam shut, the valve or pipeline could be damaged or fail due to hydraulic transients in the piping system. This condition can often be avoided by using a swing check valve with an outside weight and lever or damper.

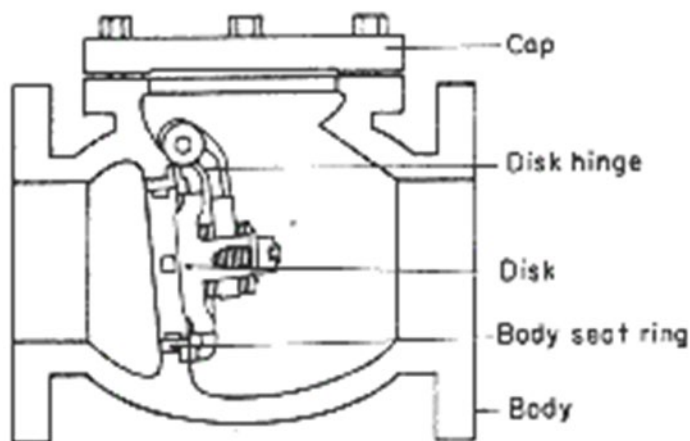

Figure 6. Check valve components.

2.9.7 Pressure-Relief and Safety Valves

Pressure-relief valves are primarily used in liquid service applications, and pressure safety valves are used in gaseous service operations (Figure 7). Both types of these valves prevent excessive pressures in piping systems and equipment, which subsequently protects the piping system from failure. When using these types of valves, it is important to use materials in the valves that will not be corroded by the liquid or gas; install the valves so they are not subject to back pressure; install the valves so they do not have to discharge to remote locations, which could increase the backpressure; or allow someone to bypass the valve so that it is isolated. Also, if using these valves in a series configuration, ensure proper engineering is performed to avoid a potential surging effect.

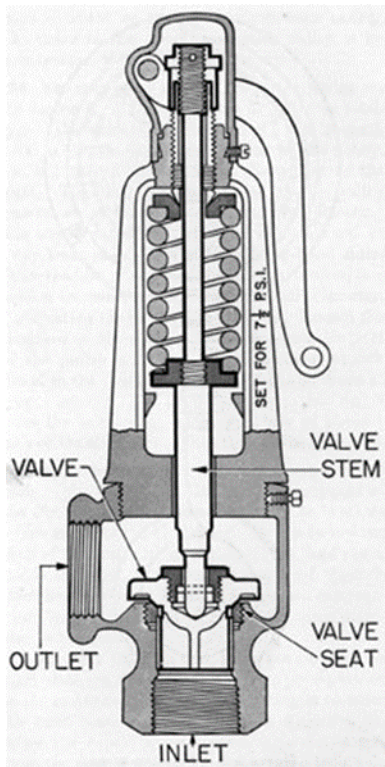

Figure 7. Pressure relief safety valve components.

2.9.8 Pressure-Reducing Valves

Pressure-reducing valves are primarily used to maintain a constant and reduced pressure in a piping system that is supplied from a higher pressure source (Figure 8). There are generally two types of pressure-reducing valves: (1) the simple rubber diaphragm type, in which the valve opening is controlled by the pressure on the diaphragm from the reduced side of the valve, or (2) the more complicated pilot-operated type, which involves a pilot valve that is controlled by the reduced-pressure side and, in turn, controls the main valve opening.

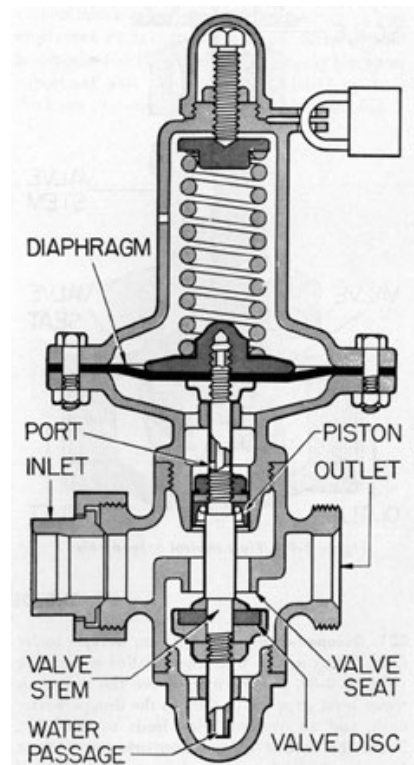

Figure 8. Pressure reducing valve components.

Pressure-reducing valves tend to wear at the disk and seat because of continual throttling action. This wear is made worse in many installations, because of a tendency to select a valve which is too large for the intended application. When sizing a pressure-reducing valve, the valve manufacturer should be given the operating pressure and temperature conditions, along with the flow rate required, so that the correct size valve can be selected for a particular application.

2.9.9 Valve Operators

The operators to control the position of valving are available in many different configurations and types. Quarter-turn and multi-turn operators are available to mount on the valve body or remotely by use of a floor stand with a connecting shaft. Operators can be configured to be in-line with the valve body or at a 90-degree angle by utilizing gearing in the operator housing.

Manual operators can be configured as quarter-turn hand levers for butterfly, ball, and plug valves or as hand wheels for gate and globe valves. Gear operators should be considered to reduce the operating torque for easy operation even under high differential pressure conditions. When the manual valve operator is at an elevation which cannot be reached from the floor, a chain operator extending from the valve to the floor is often used for convenience of operating personnel.

Electric, pneumatic, or hydraulically powered operators are available for most types of valves. Powered valve actuators are frequently used when a valve is remotely located from the main working area, when the required frequency of operation of the valve would require unreasonable time and effort, or when the rapid opening and/or closing of a valve is required.

2.10 Instrumentation

2.10.1 General

Instrumentation can be used to control, protect, indicate, and monitor the condition of auxiliary mechanical systems. When installing piping systems and equipment, the designer should determine what types of instrumentation should be provided to properly operate and monitor the performance and condition of the system equipment and devices. Instrumentation can provide operation and maintenance personnel valuable information concerning actual operating conditions and will assist in the troubleshooting and diagnosis of problems that occur. The following instrumentation is useful in monitoring and indicating the operating conditions of plant auxiliary mechanical systems.

2.10.2 Pressure Gauges

Pressure gauges are useful in determining the pressure at a particular point in a piping system. Pressure gauges can be of the single pressure, differential pressure, or duplex pressure type. They can be obtained in various accuracies in conformance to standard ASME B40.100 "Pressure Gauges and Gauge Attachments". A 2½-percent Grade A accuracy is typically used in power and pumping plants. Pressure gauges are commonly used on the suction and discharge sides of pumping units; upstream and downstream of pressure-reducing valves; at the inlet in a raw, domestic, fire-suppression, or cooling water supply system; on hydropneumatic tanks, oil tanks and air receivers; on the discharge of air compressors; on the sewage ejector air inlet; and on the inlet and outlet of filters and strainers to indicate the differential pressure drop. Pressure gauges with a minimum 4½-inch dial face are normally used so that they can be easily read by plant personnel.

2.10.3 Thermometers

Thermometers should be provided wherever it would be beneficial to know the operating temperature of a particular piece of equipment or fluid. Typical uses are to indicate the temperature of the supply and discharge of cooling water and oil from generators, motors, turbines, pumps, heat exchangers, bearings, and mechanical seals. To avoid any possible contamination from mercury, thermometers containing a nontoxic, environmentally friendly fluid should be used.

2.10.4 Rate-of-Flow Gauges

Rate-of-flow gauges are often used to determine the actual flow rate of cooling water and oil from generators, motors, turbines, pumps, heat exchangers, bearings, and mechanical seals. In order to balance the flow of cooling water through the various water-cooled bearings and heat exchangers of plant equipment, plant personnel use the information obtained from rate-of-flow gauges to adjust the flow of fluid by throttling the discharge valves from this equipment.

2.10.5 Pressure Switches

Pressure switches are commonly used to control the on/off operation of various pumping units, compressor units, and other plant equipment. Pressure switches are also used as a starting interlock or safety device in systems where it must be known if the water or oil in a system has reached the required operating pressure. If, in addition to the required pressure being obtained, the actual flow of fluid through a piping system must be confirmed, a flow switch will also be needed.

2.10.6 Elapsed-Time Meters

Elapsed-time meters are typically installed on all operating equipment, such as pumping units and compressors, to measure the elapsed time the equipment has operated so that periodic maintenance can be scheduled and conducted.

2.10.7 Liquid Level and Sight Flow Gauges

Liquid level and sight flow gauges are used to determine the liquid level in tanks, reservoirs, and sumps to indicate when fluid must be added for proper operation of the applicable mechanical system.

2.11 Maintenance of Auxiliary Piping Systems

Auxiliary piping systems include:

- gravity drainage and unwatering systems;
- cooling water systems;
- service-water systems,
- domestic water and sanitary waste systems,
- oil systems; and
- compressed air systems.

Inspect the auxiliary piping systems, including the condition of the piping, fittings, valves, and strainers.

The following steps shall be performed to inspect auxiliary piping systems:

- 1) Inspect pipes for signs of corrosion leaks, cuts, gouges, and other damage.
 - a) Visually inspect all threaded, welded, and flanged fittings, checking for any leaks or corrosion. Replace or tighten fittings or pipe as required. Check pipe hangers and supports to make sure they are carrying their share of the load and that anchors are tight. Examine paint for cracking, chalking, or other deterioration. Remove corrosion by wire brushing, sandblasting, or other acceptable method and repaint.
 - b) If there is evidence of significant wall loss or severe damage, visually inspect or perform nondestructive testing on interior surfaces of piping. If disassembling pipes for inspection with the intent to reinstall the old components, use caution and have replacement parts on hand prior to system disassembly.
- 2) Visually inspect piping system components such as valves and fittings. Check all threaded, welded, and flanged fittings for leaks and/or corrosion. Inspect valves for external leaks. Repair as required.
 - a) Exercise all auxiliary piping system valves by operating through their full range of motion several times. The operation of valves prevents seizing components.
 - b) With the valve closed and under pressure, check for seat leakage by listening or by using pressure gauges.
 - c) Check valve stem packing for leaks and tighten packing gland as required. Operate valve through its full range of movement several times. With valve closed under pressure, listen

- for leakage past valve and correct as required. Lubricate the valve stems, plug valve seats, and other components as required with appropriate lubricant.
- d) Disassemble valve and inspect condition of valve body, stem, and sealing surfaces and repair as required. Completely remove old valve stem packing and install new packing.
 - 3) Inspect pressure-regulating and pressure-reducing valves for operation and setting. Disassemble and remove any scale build-up that interferes with operation as required.
 - 4) Clean strainers as necessary to clear plugging or fouling. Corrosion should be corrected by repairing or replacing strainers.
 - 5) Remove and calibrate each pressure gauge on auxiliary piping systems and pressure vessels.

3.0 Air Compressors

3.1 General

Air compressors are a common piece of equipment found in most power generation plants, pumping plants, and maintenance shops. Many different types of compressors are available. The two most common types used by Reclamation are the reciprocating and the rotary screw compressors. Typical equipment of compressed air systems include air compressors, air receivers, air dryers, instrumentation, pressure piping, air hose outlets, cooling piping, and control valves. Figure 9 shows a simple layout of a compressed air system and typical components. Prior to performing maintenance on compressed air equipment, plant personnel should refer to the manufacturer's maintenance instructions and recommended maintenance intervals.

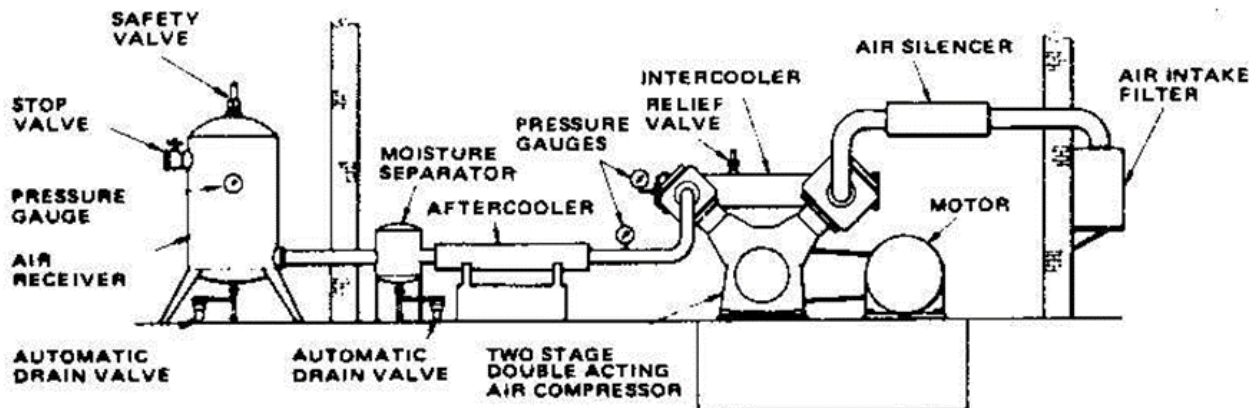

Figure 9. Simple compressed air system.

3.2 Reciprocating Air Compressors

Reciprocating compressors have been available for many years in a variety of sizes and configurations, and they make up the majority of air compressors found in plants and maintenance shops (Photograph 13). They are relatively efficient and simple to operate and maintain. Most reciprocating compressors can be overhauled completely with a minimum of tools and parts.



Photograph 13. Reciprocating type air compressors.

A reciprocating compressor uses a reciprocating piston to compress air in a cylinder against a cylinder head. While all reciprocating compressors operate in basically the same manner, there are many variations in their construction. For example, a reciprocating compressor can be single- or multi-cylinder, single- or double-acting, single- or multi-stage, and air or water cooled, and it can have a horizontal, vertical, or angled cylinder arrangement. Other variations are possible, depending on the application.

Single-acting compressors use automotive-type pistons, connected directly to the crankshaft by connecting rods, and compress air on one side of the piston only. Double-acting compressors have a double-acting piston, compressing air on both sides, driven by a piston rod that extends through a packing box. The piston rod is connected to a crosshead, which is connected to the crankshaft by a connecting rod. Both single- and double-acting compressors are available as single- or multi-stage. Multi-stage compressors develop their final pressure in steps by connecting the discharge of the first stage, through an intercooler, to the intake of the second stage. The intercooler removes the heat of compression of the first stage using either air or water as a cooling medium. Figure 10 is a section view of a two-stage air compressor.

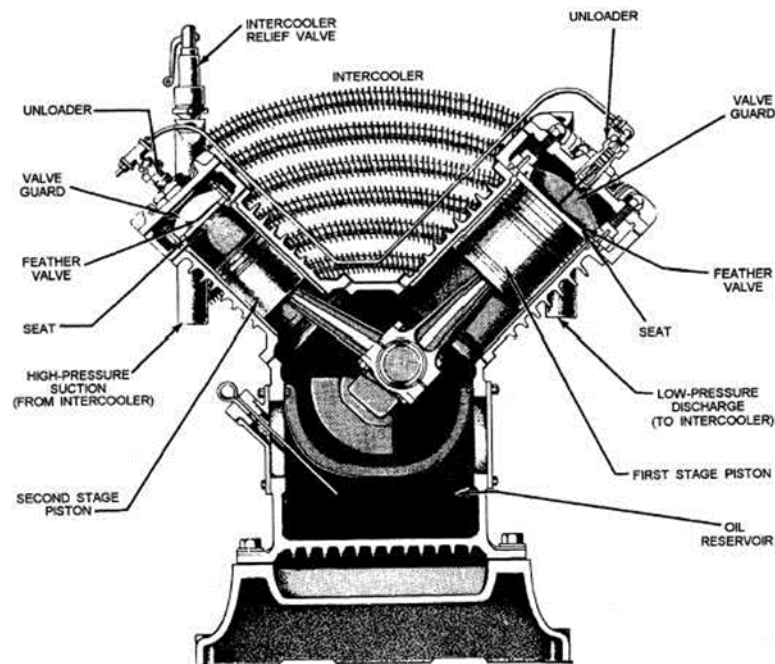

Figure 10. Two-stage reciprocating compressor.

3.3 Rotary Screw Air Compressors

Rotary screw air compressors (Photograph 14) use two meshing helical-shaped rotors to compress air (Figure 11). As the rotors turn, air is compressed by the advancing helix. The rotor may be oil-flooded or dry. Dry rotor compressors require the use of timing gears to maintain proper clearance between the rotors. The oil in the oil-flooded type compressor lubricates and seals the rotors and acts as a coolant to remove the heat of compression. The oil-flooded type does not require timing gears, as the oil film prevents contact of the rotors, but an air-oil separator is necessary to remove the oil suspended in the compressed air as it leaves the compressor.



Photograph 14. Rotary screw type air compressor.

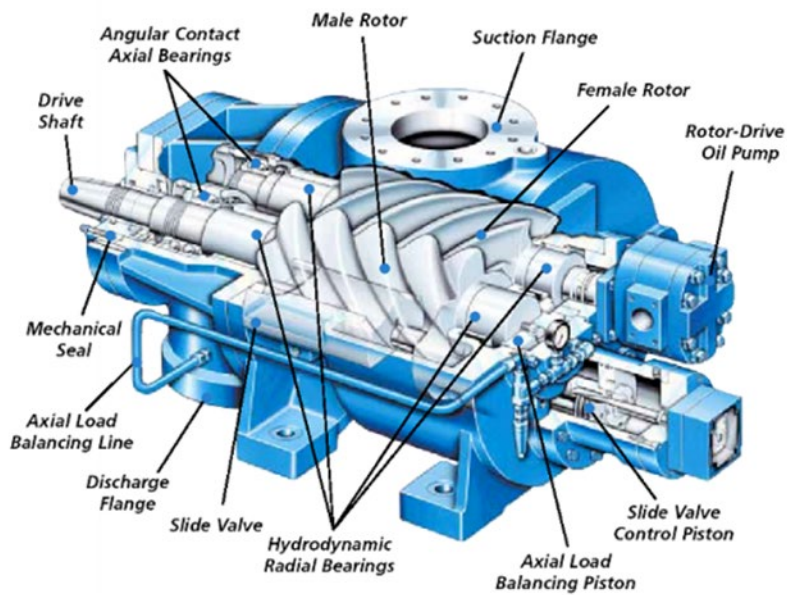

Figure 11. Cutaway view of a twin-screw reciprocating compressor.

Maintenance of Auxiliary Mechanical Equipment

Rotary screw compressors have fewer moving parts than reciprocating compressors and provide a smooth, nearly pulse-free air supply. Rotary screw compressors are typically provided in a “package” which only requires connections to electrical power, service air piping, and in some cases, water as a cooling medium. Since there is little vibration, they generally operate with lower noise emissions and do not require the massive foundation a comparable reciprocating compressor would need. They are also very popular in trailer-mounted, internal combustion engine driven portable compressors.

The construction of rotary screw compressors is such that little maintenance can be accomplished in the field by plant personnel. The lubricating oil should be filtered regularly, as tight tolerances make clean oil a necessity. The air end (i.e., rotors and their housing) of the rotary screw compressor has no significant wear items, such as piston rings of the reciprocating type. Since the air end is constructed with such high precision and tight tolerances, in most cases, the entire air end must be replaced as a unit. Some units have sacrificial anode components in the aftercoolers/intercoolers.

3.4 Air Compressor Accessories

3.4.1 Inlet Filters

Inlet filters prevent dust and other particulates from entering the compressor. Rotary screw compressors are especially susceptible to wear or damage from dirt particles.

3.4.2 Intercoolers and Aftercoolers

Intercoolers are mechanical heat exchangers installed between the first and second stage of a two-stage compressor to lower the discharge temperature, remove moisture, and increase the density of the air entering the second stage. This intermediate stage transfers heat via air or liquid and results in an increased compressor efficiency.

Like intercoolers, aftercoolers are also mechanical heat exchangers, but instead are installed on the air discharge line. This lowers the compressed air's discharge temperature and condenses water from the air. Without aftercooling, typical outlet temperatures of compressors are 200°F for oil-injected rotary screw type, 225°F for centrifugal type, 300°F for two-stage reciprocating type, and 350°F for oil-free rotary screw type. Stationary compressors typically use water, but may use air as a cooling medium for their aftercoolers. Most water-cooled aftercoolers are appropriately sized to cool the compressed air within 10°F to 15°F of ambient air temperature.

Aftercoolers or intercoolers are usually installed with a separator and trap to handle the condensate.

3.4.3 Separators

Separators are used to remove entrained liquids from the compressed air. This is usually accomplished by changing the direction of movement of the liquid particles so they are removed from the air either centrifugally or through impingement against a separator element. The most common types of separators are impingement, centrifugal, and cyclone types.

3.4.4 Traps

Traps collect liquid that has been removed from the air by separation or condensation and release it, either automatically or through a manual valve. Traps are installed with separators, filters,

aftercoolers, receivers, and dryers. They also should be installed at the low points in distribution systems, especially on lines passing through a cold area. An in-line strainer is usually installed directly upstream of a trap to prevent sediment or other contamination from clogging the trap.

3.4.5 Dryers

Dryers are used when drier air is required than can be provided by an aftercooler/intercooler system. The most common are refrigerated dryers, which condense the moisture from the air by reducing the air temperature.

Desiccant dryers use porous moisture-adsorbing materials that hold the moisture in the pores until they are regenerated by electric heat, air purging, or both.

3.4.6 Pressure-Regulating Valves

Pressure-regulating valves are used to supply small volumes of air to various pneumatic equipment at a pressure lower than system pressure. Pressure-regulating valves are not considered to be safety devices.

3.4.7 Receiver Tanks (Pressure Vessels), Gauges and Pressure Relief Valves

Please refer to FIST 2-9, *Inspection of Unfired Pressure Vessels*, for any information regarding receiver tanks (pressure vessels) and pressure relief valves.

3.4.8 Unloader Valves

Reciprocating compressors have an unloader valve located between the discharge of the compressor and the air receiver. Unloader valves are used to minimize the load required to start a reciprocating compressor. The output of a compressor is typically connected to the air receiver through a short section of piping. When the pressure switch is activated and the compressor stops, an unloader valve opens and the pressure in this piping is blown down to atmospheric pressure. This allows the compressor motor to restart under a lower load condition. Once the compressor reaches its normal operating speed, the unloader valve closes to allow compressed air to resume flow into the air receiver.

3.5 Maintenance for All Types of Air Compressors

For all compressor types, reference the compressor manufacturer's documentation.

Perform the following steps frequently for inspection and maintenance:

- 1) Inspect the compressor structure.
 - a) Check concrete for cracks and spalling. Check foundation with level for settling.
 - b) Examine the frame for metal corrosion and cracks. Clean and paint as required.
- 2) Inspect the compressor drive system.
 - a) Check V-belts for slippage, chains for looseness, and shaft couplings for excessive runout or vibration.
 - b) Check V-belts for signs of wear or aging and replace as needed. Using a dial indicator, check for excessive runout of direct-coupled shafts; check shaft alignment if runout is excessive.

Maintenance of Auxiliary Mechanical Equipment

- 3) Inspect the compressors' cooling system.
 - a) Check flow of water coolant through compressor and aftercooler. Check for accumulation of dirt or lint on cooling fins of air-cooled compressors and radiators of water-cooled compressors.
 - b) Check for corrosion and scale buildup and clean or flush as required. Thoroughly clean cooling fins of air-cooled compressors and radiators of water-cooled compressors.
- 4) Inspect the air intake system.
 - a) Check air intake for obstructions. Check the condition of the air filter. Replace as required.
- 5) Inspect the compressor's piping and valves.
 - a) Check piping for corrosion. Replace, clean, or repaint as required.
 - b) Check valves for leakage. Repack, reseal, or replace as required.
 - c) Inspect pressure regulating valves for operation and verify the valves are providing the correct pressure downstream of the valve.
- 6) Inspect the separator.
 - a) Check for leaks. Disassemble and check for internal corrosion and scale buildup as required.
- 7) Operate and inspect traps.
 - a) Drain manual traps
 - b) Check automatic traps for leaks and proper operation. Clean strainer and inspect for corrosion or scale buildup.
- 8) Maintain the air dryers.
 - a) Check for operation of refrigerated and desiccant type dryers.
 - b) Replace dryer elements on deliquescent type dryers as necessary.
- 9) Inspect and maintain the compressor's gauges.
 - a) Check operation of each gauge. Look for a loose or stuck pointer. If there is any doubt about the accuracy of a gauge, remove it and check its calibration or replace it with a new gauge.
- 10) Inspect the operation of pressure and temperature switches.
 - a) Verify that pressure switches cut in and out at proper pressures. Check settings of temperature switches.
 - b) Check pressure and temperature switch calibration and set points.
- 11) Inspect and maintain compressor bearings.
 - a) Check anti-friction bearings for excessive vibration or noise and for adequate lubrication.
 - b) Disassemble compressor and inspect condition of all bushings and Babbitt-lined bearings as required. Replace as needed.

3.6 Maintenance for Reciprocating Compressors

For this section on reciprocating compressors, reference the compressor manufacturer's documentation to perform the following steps for the inspection and maintenance:

- 1) Inspect and maintain the lubrication system.
 - a) Check that oil or grease cups are full and fill as necessary. Ensure that the crank case oil and/or oil reservoir is filled to the proper level with the correct lubricant. Check oil feed rate to cylinder. Check forced oil systems for proper operation. Note any leaks and repair if necessary.
 - b) Clean oil or grease cups and piping. Check condition of lubricant and change if required.

- 2) Inspect and maintain the packing gland.
 - a) Check for excessive leakage and for scoring on piston rod. Adjust packing as necessary.
 - b) Check condition of packing and replace if necessary.
- 3) Inspect and maintain the unloader.
 - a) Check that the unloader is functioning correctly, allowing the compressor to reach operating speed before loading followed by unloading at the proper pressure.
 - b) Inspect valves and air lines for leaks. Inspect valves for proper seating. Lap valves if required. Examine solenoid for deteriorated insulation or loose connections.
- 4) Inspect and maintain the crosshead.
 - a) Check fit and lubrication of crosshead if accessible.
 - b) Check bearing shoes for scoring, wear, and fit to crosshead. Shim shoes to obtain proper fit if necessary. Check pin and bushing for wear and replace or refit as required.
- 5) Inspect and maintain the cylinder.
 - a) Check cylinder walls for wear and scoring. Measure inside diameters at top, bottom, and middle in two directions, 90 degrees apart. If cylinder is out-of-round or oversized according to manufacturer's documentation, re-bore or replace the cylinder.
- 6) Inspect and maintain the piston.
 - a) Check piston for wear and clearance within the bore. Examine rings for tightness and fit. Replace if necessary.
- 7) Inspect and maintain the connecting rod.
 - a) Visually inspect for distortion or bending.
 - b) Check connecting rod for trueness, scoring or wear. Refurbish or replace as required.
 - c) Inspect bearing fasteners for damage and replace as required.
- 8) Inspect and maintain the intake and discharge valves.
 - a) Inspect valves and seats for scoring and proper seating. Clean any deposits off valve plates and seat, being very careful not to scratch the surfaces. Lap valve seats if there are any imperfections. Deposits on the valves indicate a dirty intake, the wrong type or excessive oil, or a leaking valve or valve gasket.

3.7 Maintenance for Rotary Screw Compressors

For this section on rotary screw compressors, reference the compressor manufacturer's documentation to perform the following steps for the inspection and maintenance:

- 1) Inspect and maintain the compressor air end.
 - a) Visually inspect rotors and bearings for wear. Replace if necessary or if compressor efficiency has noticeably declined.
- 2) Inspect and maintain the system's oil reservoir, separator, and oil filter.
 - a) Drain condensate from the bottom of oil reservoir.
 - b) Visually inspect condition of separator element. Service or replace as necessary. Clean or replace the oil filter as required.

4.0 Heating, Ventilating, and Air-Conditioning (HVAC) Systems

Heating and ventilation systems in hydroelectric powerplants and pumping plants are not only important to maintain the comfort of personnel working in the plant but also to maintain proper operating conditions for plant equipment. Ventilating equipment may vary in complexity.

HVAC commissioning is a thorough and comprehensive testing of a mechanical system's performance. HVAC systems should be commissioned periodically to ensure they are functioning as detailed in the facility's SOP and that they meet current operation requirements, some of which may have changed since the writing of the SOP (e.g., storage room converted to a conference room).

General commissioning processes consist of operating HVAC systems through each of the anticipated modes of operation (heating, cooling, ventilation, emergency, occupied, unoccupied, etc.) utilizing control systems (thermostats, switches, etc.) and then verifying, through physical observation and measurement of airflow and temperatures, that the systems are operating as required.

Maintenance and operations procedures should be reviewed based on the previous year's operational performance and adjusted as necessary.

4.1 Maintenance of HVAC Systems

- 1) Inspect and maintain the cooling fan(s).
 - a) Visually and audibly inspect fan(s) for abnormal/excessive vibration or noise. Replace bearings or balance as required.
 - b) Check and clean fan blades as necessary. Lubricate fan motor bearings as required. Replace bearings or balance as necessary.
- 2) Inspect and maintain belts and pulleys.
 - a) Check belts for condition, tension, and alignment. Adjust or replace as necessary. Check for wear on pulleys and replace as necessary.
- 3) Inspect filters.
 - a) Visually inspect filters. Clean or replace as necessary.
- 4) Inspect cooling or heating coils.
 - a) Visually inspect heating or cooling coils for leaks. Clean as necessary. Remove cleanout plug in strainer and flush out. Replace strainer gasket if necessary.
- 5) Maintain intake, louvers, and screens.
 - a) Clean intake, louvers, and screens as necessary.
 - b) Ensure the areas near intakes are free from debris or contaminants.
- 6) Inspect and maintain dampers.
 - a) Visually inspect dampers for freedom of motion. Lubricate bearing points as necessary.

5.0 Engine Generator Sets

Engine generator sets are important systems at powerplants, dams, and other water-related facilities (Photograph 15). They require maintenance and testing regularly to ensure they perform as expected. Engine generator sets provide power to supply an electrical load in the event of loss of the normal power source. Engine generator power may be needed to operate spillway or outlet gates/valves for water-release purposes. Powerplant critical loads such as sump pumps, fire pumps, and battery chargers also are dependent on reliable power. Engine generator sets may also be used to power unit auxiliaries and the generator excitation system for blackstart (generators assigned to restore the power system after a blackout). Many facilities rely on their specific manufacturer's maintenance recommendations.



Photograph 15. Engine generator set and fuel supply tank.

Engine generator sets are typically powered by the following types of engines:

- Otto Cycle (spark-ignited) utilizing liquid petroleum (gasoline) or liquid petroleum gas (LPG, propane/butane mixture)
- Diesel Cycle utilizing liquid petroleum (diesel)

EPSS and standby power supply systems, comprising of engine-generators and associated equipment such as automatic transfer switches, must be maintained, inspected, and tested in accordance with the manufacturer's recommendations or the NFPA 110, Standard for Emergency and Standby Power Systems. Annex A, Figure A.8.3.1 (a) has a complete maintenance schedule. Testing and maintenance records for engine generator sets should be maintained and stored on site.

Maintenance on, inspection, and testing of engine generators must be completed as outlined in POM Form 400 and NFPA 110, Chapter 8.

POM 400 form lists weekly, monthly, quarterly, semiannual, and annual maintenance tasks based on the two levels of EPSS, described as follows:

(FIST 020) 08/01/2022

NEW RELEASE

Maintenance of Auxiliary Mechanical Equipment

Level 1 EPSS maintenance, inspection, and testing are required where failure of the engine generator system could result in the loss of human life or a serious injury, per NFPA 110, Chapter 4. This includes engine generators required for life safety equipment and for support of plant systems related to personnel safety. These tend to be Type 10 (10 second between loss of power and engine generator fully assuming emergency loads).

Level 2 EPSS maintenance, inspection, and testing are applicable where failure of the emergency power supply system is less critical to human life and safety and where flexibility greater than Level 1 is permissible (NFPA 110, Chapter 4). Level 2 maintenance, inspection, and testing apply where the emergency power supply system is utilized for water release purposes (via gate or valves) and where no significant damage to the plant would occur if the system fails. This classification is not common at Reclamation facilities.

Standby power supply systems are those systems that do not provide power to emergency loads, are classified under Level 2 EPSS. This is the most common type of engine generator set used in Reclamation facilities. Common loads may include lighting, sump pumps, or gate operators. Generally standby power systems aren't capable of powering all motors, gates, and facility loads. Typically, only loads required for the safety of the facility are powered by the standby system. Black start facility capabilities would be considered a standby system.

5.1 Maintenance of Engine Generator Sets

For this section on engine generator sets, reference POM Form 400 and the manufacturer's documentation to assist in performing following steps for the inspection and maintenance:

- 1) Inspect and maintain EPSS Components, which include fuel, lubrication system, cooling system, exhaust system, battery system, electrical system, prime mover, and generator.
 - a) Inspect and perform maintenance for all EPSS components per manufacturer's recommendations or POM Form 400.
- 2) Inspect the generator set battery.
 - a) Visually inspect engine generator set battery. Check for signs of damage, leakage or other abnormalities.
- 3) Maintain engine generator set transfer switch.
 - a) Operate transfer switch electrically in both directions.
- 4) Maintain circuit breakers.
 - a) Manually exercise circuit breakers.
- 5) Operate engine generator set.
 - a) EPSS Level 1 and Level 2 - *Exercise for a minimum of 30 minutes at operating temperature (including automatic cold start, if equipped) by:
 - (1) Running diesel-fueled generators at operating temperature conditions and at not less than 30% of nameplate kW rating; or
 - (2) Running diesel-fueled generators by loading the system to maintain the minimum exhaust gas temperatures as recommended by the manufacturer; or
 - (3) Running spark-ignited generators under available load (typically a load bank).

FIST Volume 2-6
Maintenance of Auxiliary Mechanical Equipment

* For diesel-fueled generators, load exercising at normal operating temperature prevents accumulation of carbon particles, unburned fuel, lube oil, condensed water, and acids in the exhaust system and other engine problems that can occur with unloaded exercising.

- b) For EPSS Level 1, operate at loads defined for the assigned class duration (not less than 30% of nameplate kW rating) and a minimum of 4 hours by operating at least one transfer switch test function then by operating the test function of all remaining transfer switches.

6.0 Mechanical Drawings

In many, if not most cases, modifications made to mechanical equipment are visible and apparent to the maintenance personnel, but in cases where modifications are not apparent, the safety of maintenance personnel can be compromised if current up-to-date drawings are not available. One example of such a modification is the rerouting of high-pressure water, air, or oil piping. Also, instructional drawings, such as those provided for the operation of gates and valves, should always be kept current. If modifications are made to an existing piping system, the corresponding mechanical drawings shall also be updated to reflect the system change. Priority should be given to critical mechanical drawings of schematics that are used frequently for operations and safe clearances.

Mechanical drawings shall be updated with system changes or modifications.

Revise critical drawings, schedules, and schematics as system modifications are made for mechanical equipment, piping, and valves. Prioritize updating critical mechanical drawings that are used frequently for operations and clearances.

RECLAMATION MANUAL TRANSMITTAL SHEET

Effective Date: _____

Release No. _____

Ensure all employees needing this information are provided a copy of this release.

Reclamation Manual Release Number and Subject

Summary of Changes

NOTE: This Reclamation Manual release applies to all Reclamation employees. When an exclusive bargaining unit exists, changes to this release may be subject to the provisions of collective bargaining agreements.

Filing instructions

Remove Sheets

Insert Sheets

All Reclamation Manual releases are available at <http://www.usbr.gov/recman/>

Filed by: _____

Date: _____