



— BUREAU OF —
RECLAMATION

**Facilities Instructions, Standards, and Techniques
Volume 3-8**

Operation, Maintenance, and Field Test Procedures for Protective Relays and Associated Circuits

**Previously Titled:
Field Testing Procedures for Protective Relays**

REPORT DOCUMENTATION PAGE

Form Approved
OMB No. 0704-0188

Public reporting burden for this collection of information is estimated to average 1 hour per response, including the time for reviewing instructions, searching existing data sources, gathering and maintaining the data needed, and completing and reviewing this collection of information. Send comments regarding this burden estimate or any other aspect of this collection of information, including suggestions for reducing this burden to Department of Defense, Washington Headquarters Services, Directorate for Information Operations and Reports (0704-0188), 1215 Jefferson Davis Highway, Suite 1204, Arlington, VA 22202-4302. Respondents should be aware that notwithstanding any other provision of law, no person shall be subject to any penalty for failing to comply with a collection of information if it does not display a currently valid OMB control number. **PLEASE DO NOT RETURN YOUR FORM TO THE ABOVE ADDRESS.**

1. REPORT DATE (DD-MM-YYYY) 27/09/2021		2. REPORT TYPE Final		3. DATES COVERED (From - To)	
4. TITLE AND SUBTITLE FIST 3-8, Operation, Maintenance, and Field Test Procedures for Protective Relays and Associated Circuits				5a. CONTRACT NUMBER	
				5b. GRANT NUMBER	
				5c. PROGRAM ELEMENT NUMBER	
6. AUTHOR(S) Paul Price, Nate Myers, Jim DeHaan Bureau of Reclamation Hydropower Technical Services Group Denver, Colorado				5d. PROJECT NUMBER	
				5e. TASK NUMBER	
				5f. WORK UNIT NUMBER	
7. PERFORMING ORGANIZATION NAME(S) AND ADDRESS(ES) Hydropower Technical Services Group, Bureau of Reclamation Denver Federal Center P.O. Box 25007 Denver CO 80225-0007				8. PERFORMING ORGANIZATION REPORT NUMBER FIST 3-8	
9. SPONSORING / MONITORING AGENCY NAME(S) AND ADDRESS(ES) Power Resources Office, Office of Policy Bureau of Reclamation Mail Code 86-68450 PO Box 25007 Denver CO 80225-0007				10. SPONSOR/MONITOR'S ACRONYM(S) DIBR	
				11. SPONSOR/MONITOR'S REPORT NUMBER(S)	
12. DISTRIBUTION / AVAILABILITY STATEMENT Available from the National Technical Information Service, Operations Division, 5285 Port Royal Road, Springfield, Virginia 22161					
13. SUPPLEMENTARY NOTES					
14. ABSTRACT The Bureau of Reclamation (Reclamation) operates and maintains 58 hydroelectric powerplants and many switchyards, pumping plants, and associated facilities that are important to electric power and water delivery systems. These facilities house complex electrical and mechanical equipment; and protective relays and associated circuits play an essential role in protecting this equipment as well as the electric power system. This document defines Reclamation practices for operating, maintaining, and testing protective relays and protection circuits. The Western Electricity Coordinating Council, North American Electric Reliability Council, National Fire Protection Association, and Reclamation practices are the basis of these practices. Included in this document are standards, practices, procedures, and advice on day-to-day operation, maintenance, and testing of existing relaying systems, which also includes periodically verifying relay settings furnished by others.					
15. SUBJECT TERMS current transformer, potential transformer, power system testing, protective systems, relays					
16. SECURITY CLASSIFICATION OF:			17. LIMITATION OF ABSTRACT	18. NUMBER OF PAGES 123	19a. NAME OF RESPONSIBLE PERSON Hydropower Technical Services Group
a. REPORT	b. ABSTRACT	c. THIS PAGE			19b. TELEPHONE NUMBER (include area code) 303-445-2300

**Facilities, Instructions, Standards, and Techniques
Volume 3-8**

Operation, Maintenance, and Field Test Procedures for Protective Relays and Associated Circuits

Hydropower Technical Services Group

Disclaimer

This written material consists of general information for internal use only by Bureau of Reclamation operations and maintenance staff. Information contained in this document regarding commercial products or firms may not be used for advertising or promotional purposes and is not to be construed as an endorsement or deprecation of any product or firm by the Bureau of Reclamation.

Acronyms and Abbreviations

A	ampere
ac	alternating current
amp	ampere
ANSI	American National Standards Institute
BES	bulk electric system
CARMA	Capital Asset and Resource Management Application
CCVT	coupling capacitor voltage transformers
CO₂	carbon dioxide
CT	current transformer
dc	direct current
DIP	dual in-line package
DMM	Digital Multimeter
EC&M	Electrical Construction and Maintenance
EPAct	U.S. Energy Policy Act of 2005, Public Law 109-58
FERC	Federal Energy Regulatory Commission
FIST	Facilities Instructions, Standards, and Techniques
GE	General Electric
HMI	Human-Machine Interface
Hz	hertz
IEC	International Electrotechnical Commission
IEEE[™]	Institute of Electrical and Electronics Engineers
JHA	job hazard analysis
kV	kilovolt
LAN	local area network
LED	light emitting diode
MTA	maximum torque angle
NERC	North American Electric Reliability Corporation
NFPA	National Fire Protection Association
O&M	operation and maintenance
PC	personal computer
PO&M	Power Operation and Maintenance
PT	potential transformer
Reclamation	Bureau of Reclamation
RCM	Reliability Center Maintenance
rms	root mean square
RRIS	Reclamation Relay Information System
RTDs	resistance temperature devices
SCADA	Supervisory Control and Data Acquisition
SPS	special protection system
Std.	Standard

V	volt
VA	voltampere
Vdc	volts direct current
WECC	Western Electricity Coordinating Council
°	degree
%	percent
Ω	ohms

Table of Contents

	<i>Page</i>
Acronyms and Abbreviations.....	iii
1. Introduction.....	1
1.1 Purpose and Scope.....	1
1.2 Definitions.....	2
1.3 References.....	2
2. Reclamation Relay Regulatory Requirements.....	4
2.1 Protection System Misoperation Reporting.....	4
2.2 Protection System Devices Covered.....	4
2.3 Protection System Devices.....	5
3. Protection System Maintenance Summary Table.....	7
4. Protective Relays.....	11
4.1 Relay Settings.....	11
4.2 Test Records and Power Operation and Maintenance (PO&M) Forms.....	11
4.3 Relay Information System Database.....	12
4.4 Qualifications, Peer Review, and Training.....	13
4.5 Relay Users Group.....	13
5. Instrument Transformers.....	15
5.1 Burden Calculations and Measurements.....	15
5.2 Checking Grounds, CT and PT Circuits.....	16
5.3 Insulation Resistance Testing for PT and CT Secondaries.....	16
5.4 Polarity, Phasing, and Connections.....	17
5.5 Ratio Tests for Potential and Current Transformers.....	17
6. Current Transformer Excitation Tests.....	19
7. Danger – High Voltage from Open CT Secondary Circuits.....	20
8. Plant Protection System Functional Testing.....	21
8.1 Primary and Secondary Injection Test Techniques.....	21
8.2 Segmented Test Techniques.....	21
8.3 Online Testing Techniques.....	23
8.3.1 Online Functional Tests.....	24
8.3.2 Online Measurements.....	24
8.3.3 Post-Event Analysis.....	24
8.4 Protection System Failure Modes.....	24
9. Lockout Relays and Lockout Circuit Functional Testing.....	26
9.1 Possible Lockout Relay Failure Modes.....	26
9.2 Lockout Relay Maintenance Procedures.....	27
9.3 Additional Breaker Control Relays and Circuits.....	29
9.4 Red and Amber Light Indications/Relay Trip Circuit Monitoring.....	29
9.5 Protection Circuit Low Voltage Testing.....	31
10. Protection System Drawings.....	32
11. Testing Equipment and Software.....	33
11.1 Online Relay Testing Precautions.....	34
11.2 Records.....	34

Table of Contents (continued)

	<i>Page</i>
11.3 Record Retention.....	35
12. Electromechanical Relay Calibration Procedures.....	36
12.1 Frequency of Testing	36
12.2 Commissioning and Maintenance Visual Checks.....	36
12.3 Electromechanical Relay Maintenance Test Procedures.....	37
12.4 Auxiliary Relays.....	39
12.5 Time-Overcurrent and Time-Overvoltage Relays.....	39
12.6 Directional Overcurrent Relays.....	40
12.7 Distance Relays	40
12.8 Differential Relays	40
12.9 Temperature Relays and Resistance Temperature Devices.....	40
12.10 Pressure Relays.....	41
12.11 Sudden Pressure and Buchholz Relays.....	41
13. Solid-State Relays	42
13.1 Frequency of Testing	42
13.2 Testing Requirements	42
13.3 Commissioning and Maintenance Visual Checks.....	43
13.4 Calibration and Testing Techniques	43
13.5 Testing Procedures	44
14. Microprocessor (Digital) Relays	46
14.1 Testing Precautions	46
14.2 Frequency of Testing	47
14.3 Commissioning and Maintenance Visual Checks.....	47
14.4 Functional Testing Techniques	48
14.5 Relay Functional Testing.....	48
14.6 Unmonitored/Monitored Relays.....	49
14.7 Relay Input/Output Function Testing	50
14.8 Testing Programmable Logic	51
14.9 Communication Equipment Used in Conjunction with Protective Relaying	51
14.10 Documenting Microprocessor Relay Settings.....	52
Appendix A – Glossary of Terms Protective Relaying and Protection Circuits.....	55
Appendix B – Electrical Device Numbers Definitions and Functions	71
Appendix C – Current Transformer Accuracy Classes.....	79
Appendix D –Instrument Transformer Burden Measurements for Current Transformers and Potential Transformers	83
Appendix E – Field Testing of Relaying Current Transformer.....	89
Appendix F – Field Testing of Relaying Potential Transformer.....	101
Appendix G – Instrument Transformer Secondary Grounding.....	105
Appendix H – Protection System Primary and Secondary Injection Test Methods	107

Table of Contents (continued)

	<i>Page</i>
Appendix I – Adjustment of Westinghouse Type KD Relays	109
Appendix J – General Electric Company Relays.....	111
Appendix K – Relay Settings Change Form	115

1. Introduction

The Bureau of Reclamation (Reclamation) operates and maintains 58 hydro-electric powerplants and many switchyards, pumping plants, and associated facilities in the 17 Western United States. These facilities are critical to the electric power and water delivery systems relied on by many. These facilities house complex electrical and mechanical equipment that must be kept operational. Protective relays and associated circuits play an essential role in protecting this equipment as well as protecting the electric power system.

1.1 Purpose and Scope

This document defines Reclamation practices for operating, maintaining, and testing protective relays and protection circuits. The National Fire Protection Association (NFPA) and historic Reclamation practices are the basis of this volume. Reclamation facilities following this Facilities Instructions, Standards, and Techniques (FIST) document on relay and relay systems testing and maintenance will comply with North American Electric Reliability Corporation (NERC), Western Electricity Coordinating Council (WECC), NFPA, and FIST 4-1B standards.

Included in this document are standards, practices, procedures, and advice on day-to-day operation, maintenance, and testing of existing protection systems. This includes periodically verifying relay settings furnished by others.

This volume does not cover selection, design, or installation of new protective relaying systems or calculations of relay settings. It also does not cover verifying circuits or testing devices involved with metering, such as metering instrument transformers or watt-hour meters. For this, refer to the specific manufacturer's information.

FIST volumes are Reclamation documents that describe time-based activities used in the operations and maintenance of power facilities. FIST volumes provide instructions, practices, procedures, and techniques useful in conducting operations and maintenance (collectively called power operation and maintenance (O&M) activities). FIST volumes, in general, contain suggestions and recommendations related to power O&M activities, which are provided for consideration by the local/area offices. Any assertion in the FIST volumes to a requirement or mandatory activity that is not included in a *Reclamation Manual* under the various Directive and Standards is to be adopted by the respective local/area office. The adoption of other techniques must be implemented via a variance. These other techniques must be consciously chosen, technically sound, effectively implemented, and properly documented. The alternative to a time-based maintenance program includes a condition-based maintenance program or a Reliability Centered Maintenance (RCM) based program that may justify longer (or shorter) time intervals.

To distinguish which activities require a variance, this FIST will distinguish between requirements, mandatory activities, and other suggested activities. Throughout the FIST:

- **[Instructions, standards, and techniques that are a requirement or mandatory activity for all Reclamation facilities are bracketed and provided in bold text.]**
- Suggestions and recommendations related to the explanation and implementation of power O&M activities are provided in normal print.
- Supporting narratives to emphasize text and offer background information to the reader are provided in Arial print and noted with “**Caution:**” or “**Note:**.”

1.2 Definitions

Appendix A is a glossary of relay terms used in protective relaying and protection circuits.

Appendix B is a glossary of electrical device numbers definitions and functions used in protective relaying and protection circuits.

1.3 References

American National Standards Institute (ANSI)/Institute of Electrical and Electronics Engineers (IEEE™) Standard (Std.) C57.13.3 – 1983. *Guide for the Grounding of Instrument Transformer Secondary Circuits and Cases.*

Basler Electric Company. *Commissioning Numerical Relays*, Mike Young and John Horak.

Beaty, H. Wayne. *Handbook of Electric Power Calculations*, Third Edition, section 15.2, 2001.

Blackburn, J. Lewis. *Protective Relaying: Principles and Applications*, Second Edition, sections 5.2 and 5.6.3, 1998.

Bureau of Reclamation. *FIST 4-1B, Maintenance Scheduling for Electrical Equipment.*

Electrical Construction and Maintenance (EC&M). *Solid-State Protective Relay Maintenance*, April 1, 2005.

EC&M. *What to Know About Protective Relays*, February 1, 1995.

- General Electric (GE). *The Art and Science of Protective Relaying*, C. Russell Mason.
- General Electric. GE Power Management Technical Publication, *Relay Testing and Maintenance*, Document Number: GET-3473B.
- Gill, Paul. *Electrical Power Equipment Maintenance and Testing*, section 7.5.3, 1998.
- IEEE™ Std. C37.2. 2008. *Standard Electrical Power System Device Function Numbers and Contact Designations*.
- IEEE™ Std. 242. 2001. *Recommended Practice for Protection and Coordination of Industrial and Commercial Power Systems*.
- IEEE™ Std. C57.13™ 1993. *Standard Requirements for Instrument Transformers*.
- IEEE™ Std. C57.13.1. 1981. *Guide for Field Testing of Relaying Current Transformers*.
- IEEE™ Tutorial Course. *Microprocessor Relays and Protection Systems*, Document Number: 88EH0269 1-PWR, June 1986.
- National Fire Protection Association. NFPA 70B, *Recommended Practice for Electrical Equipment Maintenance*, 2010.
- Northeast Power Coordinating Council. *Maintenance Criteria for Bulk Power System Protection*, Document Number: A-04.
- Northeast Power Coordinating Council. *Bulk Power System Protection Criteria*, Document Number: A-05.
- Northeast Power Coordinating Council. *Guide for Maintenance of Microprocessor Based Protection Relays*, Document Number: B-23.
- Sacramento Municipal Utility District. *Transmission Substation Equipment Maintenance Details*, section 10, May 1, 2004.
- Schweitzer Engineering Laboratories (SEL). *Philosophies for Testing Protective Relays*, May 1994.
- Westinghouse Electric Corporation. *Transformers Applied Protective Relaying*, 1976.

2. Reclamation Relay Regulatory Requirements

Reclamation protective relays and associated circuits must be properly maintained and tested to ensure proper protection of powerplants and switchyard equipment and systems. Protective relaying must function properly to protect the electric power system as well.

Reclamation has developed and implemented protection system maintenance and testing programs at Reclamation facilities operated and maintained directly by Reclamation staff; these programs also can be applied at facilities that are owned by Reclamation but maintained by others. All records and test reports should be documented and kept on file. Maintenance and testing requirements in this volume are reflected in the appropriate sections of FIST 4-1B, Maintenance Scheduling for Electrical Equipment.

2.1 Protection System Misoperation Reporting

Protection system misoperations need to be analyzed and a corrective action plan developed and implemented to avoid future misoperations of a similar nature. Refer to TRMR-18 and FIST 1-2, Operation and Maintenance Improvement Program, for more information on incident reporting.

[Reclamation personnel must analyze relay actions and determine if the protection system acted as designed. If the protection system did not act as designed, the misoperation must be analyzed and timely mitigation actions taken to prevent future misoperations. Any mitigation actions taken must be documented.]

2.2 Protection System Devices Covered

The protection system as defined in this volume includes “protective relays, associated communications systems, voltage and current sensing devices, station batteries, and direct current (dc) control circuitry. This FIST applies to all protection systems located within Reclamation facilities and to all Reclamation facilities.

2.3 Protection System Devices

The protection system includes protective relays, associated communications systems, voltage and current sensing devices, station batteries, and direct current control circuitry.

For transmission protection systems this includes, but is not necessarily limited to:

- Distance Relays
- Directional and Nondirectional Ground Relays
- Directional and Nondirectional Over Current Relays
- Transformer Differential Relays
- Bus Differential Relays
- Phase Balance Relays
- Breaker Failure Relays
- Auxiliary Tripping Relays (a.k.a. 86 relays)
- Transfer Tripping Relays including Fiber Optic, Micro Wave, Carrier Current Relay and Pilot Wire Relays

For generation protection systems this includes, but is not necessarily limited to:

- Generator Fault Protection Functions Similar to Above
- Loss of Field Relays
- Stator Ground Relays
- Reverse Power Relays
- Volts-per-hertz Relays
- Negative Sequence Over-Current Relays
- Generator Differential Relays
- Generator Bus Differential Relays
- Frequency Relays
- Out-of-step Relays, and
- Breaker Failure Relays

Other equipment condition sensing devices such as temperature control devices, pressure switches, level switches, limit switches, low vacuum, low fuel pressure, fire protection, explosion diaphragms, etc., if they are

wired to initiate a relay protection action are considered to be included in the scope of the protection system.

3. Protection System Maintenance Summary Table

[The operation, maintenance, and testing requirements with the required interval as defined in this document are summarized below in table 1. These protection system maintenance or test activities shall be performed within their respective interval. A grace period of one maintenance season (typically, grace periods are 6 months or less, and any tolerance period cannot exceed the maximum time intervals specified) is given on all time intervals.] These intervals may be modified after consulting manufacture’s maintenance or testing intervals.

Table 1 - Maintenance Schedule for Relays and Protection Circuits

Maintenance or Test	Required Interval	Reference
Fault/load study and check protection settings	5 years	Reclamation recommended practice
Electromechanical relays calibration and functional testing	Upon commissioning, 1 year after commissioning, and every year thereafter in harsh conditions and every 2 years in controlled environments After setting changes or repairs	NFPA 70B, 15.9.7 and 11.12 2010 edition Annex Table L.1
Solid-state relays calibration and functional testing	Upon commissioning, 1 year after commissioning, and every 2 years thereafter After setting changes, or repairs	NFPA 70B, 15.9.7 and 11.12 2010 edition Annex Table L.1
Microprocessor ¹ (digital) relays functional testing – Unmonitored	Upon commissioning, 1 year after commissioning, and every 4 years thereafter After setting changes, ² repairs, or firmware update	Reclamation recommended practice
Microprocessor (digital) relays functional testing – Monitored³	Upon commissioning, 1 year after commissioning, and every 6 years thereafter After setting changes, ² repairs, or firmware update	Reclamation recommended practice
Microprocessor (digital) relay input and output verification	Upon commissioning, 1 year after commissioning and 2 years thereafter After setting changes, ² repairs, or firmware update	Reclamation recommended practice
Microprocessor (digital) relay setting verification and documentation	Upon commissioning, and immediately following any event that could change settings such as after setting changes, ² repairs, firmware updates, relay testing, or following a relay operation.	Reclamation recommended practice

Maintenance Schedule for Relays and Protection Circuits (continued)

Maintenance or Test	Required Interval	Reference
Instrument transformer ratio measurement	Upon commissioning	IEEE™ Std. 57.13-1993, 6.11
Verify that acceptable instrument transformer output signals are received at the protective relay	Upon commissioning, 6 years thereafter	Reclamation recommended practice
Instrument transformer burden measurements	Upon commissioning, 6 years thereafter, when adding or replacing any device in the secondary, or after equipment or wiring modifications	Reclamation recommended practice
Current transformer internal resistance measurements	Upon commissioning	Reclamation recommended practice
Current transformer excitation test	Upon commissioning, 6 years thereafter	IEEE™ Std. 57.13-1993, 6.11
Instrument transformer secondary circuit polarity, phasing, and connections testing	Upon commissioning, 6 years thereafter, and after equipment or wiring modifications	Reclamation recommended practice
Instrument transformer secondary grounding and Insulation resistance tests	Upon commissioning, 6 years thereafter, and after equipment or wiring modifications	NFPA 70B 15.9.5 and 15.9.9, 2010 edition Annex Table K.4(c) IEEE™ Std. C57.13.3-1983, 2.2
Protection circuit functional test, between relay outputs and breaker input, including lockout relays	Upon commissioning, 2 years thereafter, and after equipment or wiring modifications	NFPA 70B 11.12.2.10 and 15.4.6.3, 2010 edition Annex Table K.4(c) Reclamation recommended practice
Check red light lit for lockout relay and circuit breaker coil continuity or Real-time lockout and breaker trip coil continuity monitor and alarm	Daily ⁴ (once per shift in manned plants or once per visit in unmanned plants)	Reclamation recommended practice Functional tests required by NFPA 70B 15.9.7, 2010 edition Annex Table K.4(c)
Sealed lockout relay timing test	Upon commissioning and every 6 years thereafter.	Reclamation recommend practice

Maintenance Schedule for Relays and Protection Circuits (continued)

Maintenance or Test	Required Interval	Reference
Non-sealed lockout relay timing test, cleaning, and lubrication Note: Lockouts may not need to be oiled or cleaned; see Manufacturer's instructions	Every 6 years and If required by the manufacturer	NFPA 70B 15.9.7, 2010 edition Annex Table K.4(c)
Protection system communications equipment and channels required for correct operation of protection systems – Unmonitored	Upon commissioning, 0.25 years thereafter, and after equipment or wiring modifications	Reclamation recommended practice
Protection system communications equipment and channels required for correct operation of protection systems – Monitored	Upon commissioning, 6 years thereafter, and after equipment or wiring modifications	Reclamation recommended practice
Drawings associated with relaying and protection current and accurate	Update upon any changes in wiring or control	Reclamation recommended practice

¹ Microprocessor relay is defined as a relay that samples the voltage or current waveform, converts these samples to a numeric value for calculations, and performs self-diagnostics. Relays that use analog circuits for comparisons or calculations in addition to a microprocessor for timing or logic are considered solid-state relays.

² Functional testing of microprocessor-based relays can be limited to a functional check of the affected element if the change is limited in scope, such as a change of a variable(s) (a pickup value, a time value, or curve type) and **all** the settings are verified correct following the setting change and functional test. Documentation of technically sound rationale to limit the functional test is required. Functional testing of the entire relay is required if changes involve a firmware update, repair, enabling or disabling a relay function or element, logic changes, or a change that affects multiple functions or elements.

³ Monitored - A microprocessor relay is considered unmonitored unless facility monitoring meets all the following requirements:

- Real time monitoring and alarm of the relay internal self-monitoring alarm
- Real time monitoring and alarm for dc supply or power supply failure
- Monitoring of trip coil continuity (either real time or via red light check interval)
- If applicable, monitoring of protection telecommunication system (real time or periodically per test interval)
- Monitoring dc battery voltage (real time or per test interval)
- Verification of relay inputs and outputs (real time or per test interval)

⁴ In staffed plants, in conjunction with daily operator control board checks. Otherwise, check each visit to the plant.

NOTE: The above table includes time interval requirements for specific maintenance or test activity based on a time-based maintenance program. The adoption of longer intervals or a change in maintenance or test activity must be documented consistent with TRMR-32. The alternative to a time-based maintenance program includes a condition-based maintenance program or a RCM-based program that may justify longer (or shorter) time intervals.

4. Protective Relays

4.1 Relay Settings

Protective relays monitor critical electrical and mechanical quantities and initiate emergency shutdown when they detect out-of-limit conditions. Protective relays must detect abnormal conditions, shut down appropriate equipment, and must not incorrectly operate and unnecessarily shut down equipment at any other time.

Electrical protective relays are calibrated with settings derived from system fault and load studies. Initial settings are provided when relays are installed or replaced. However, electrical power systems change as generation equipment and transmission lines are added or modified. This may mean that relay settings are no longer appropriate. Outdated relay settings can be hazardous to personnel, to the integrity of the powerplant and power system, and to equipment. **[Fault and load studies and relay settings are required to be evaluated on a 5-year cycle.]** This study and review is provided by the Hydropower Technical Services Group, 86-68440, at 303-445-2300. Protective relaying is crucial to protect plant equipment and the electric power system. Therefore, a relay setting must not be changed unless approved by a qualified relay engineer.

NOTE: Relays and official relay settings must not be changed from those furnished unless approved by a qualified relay engineer. New settings must be documented using a relay setting change form. See appendix K for an example.

When functional testing relays, the requirements or mandated activities referenced in this FIST apply to relay settings that could lead to a trip or alarm. Relay elements that are disabled do not need to be functional tested. Relay settings that, in effect, disable relay operation—such as setting a time delay to 9999 seconds or an overcurrent element set to 99 amps secondary—also do not need to be functional tested.

4.2 Test Records and Power Operation and Maintenance (PO&M) Forms

Records must be maintained on calibration, testing, and any mitigation action taken to correct misoperations of protective systems. This is essential for ongoing maintenance and for the Review of Power Operation and Maintenance process. It is recommended to schedule and record this testing in the Capital Asset and Resource Management Application (CARMA),² and job plan templates

² CARMA is Reclamation's solution for integrating 18 MAXIMO[®] 4 installations into a single MAXIMO 6 solution on a single platform in Denver.

reside in the planning module – job plan application. However, details of tests may be recorded on PO&M forms or in databases associated with computerized testing software. PO&M forms that apply to electromechanical relays can be found at the Reclamation forms Web site at <http://intra.usbr.gov/forms/pomforms.html>.

[When relay settings have been verified, apply “last tested” stickers to the front of the relay. These stickers should include the date of the last test and the initials of the person verifying the settings and calibration.]

4.3 Relay Information System Database

The information provided in this section has now moved to FIST 6-4 Management of Protective Relay settings.

4.4 Qualifications, Peer Review, and Training

[Staff who perform maintenance and testing on protective relays and associated circuits must be fully qualified]. Since protective relays and associated equipment are extremely important to powerplants and the Western grid, a peer review process and training program must be established. **[Relay calibration and testing procedures shall receive an initial peer review and a periodic peer review, when significant procedure changes are made by a qualified individual.]** Significant changes are when the procedure in which the relay is tested has been modified. This will include adding or removing testing elements, changes to automated testing software that changes the way an element is tested, or any other major revision to the testing program that will effect the way the relay is tested. Small facilities may need someone from another facility, regional office, or Technical Service Center (TSC) personnel to be the peer reviewer.

A qualified person must be properly trained, knowledgeable, and experienced in relay and protection system maintenance and safety, as well as testing techniques for specific protection equipment located at their facility. An indepth knowledge and understanding of the total protection system is critical to powerplant reliability and availability. The most effective training comes from a combination of classroom, personal study, on-the-job relay testing, and total protection system testing.

Staff training on automated relay testing software can enable them to test any general type of relay. However, they also must be trained on specific relays and exact protection schemes at their facility. Reclamation's Relay Users Group is available to provide assistance in all these training areas.

4.5 Relay Users Group

Reclamation relaying specialists have formed a Relay Users Group to share knowledge, software, tools, equipment, and experience and to provide assistance in relay testing and training. Anyone responsible for relay maintenance and testing is welcomed and encouraged to join this group. More information can be found at <http://intra.usbr.gov/~hydrores/relaytest/index.htm> or from the Hydropower Technical Services Group, 86-68440, at 303-445-2300.

The group coordinates Reclamation licensing of testing software to minimize costs to individual offices and sponsors annual and individual training in relay testing. It also assists individuals responsible for relay maintenance and testing to share software, test equipment, test routines, and relay specific information. For example, developing a test program for a complicated microprocessor-based relay could take several months. If the same relay is used in other Reclamation facilities, test programs can be shared among facilities. This alleviates the need for each facility to re-develop testing procedures and reduces time and costs.

5. Instrument Transformers

Instrument transformers comprise current transformers, potential transformers, and coupling capacitor voltage transformers (CCVTs), which reduce current and voltage to levels useable by protective relays and other control devices.

Instrument transformers must be properly sized and have the proper accuracy class for their specific applications. For additional information on CT and PT accuracy classes, specifications, and testing, refer to appendices C, D, E, and F.

5.1 Burden Calculations and Measurements

Instrument transformers used for protective relaying often supply other loads as well—such as meters, alarms, indicating lights, transducers, or input modules of other systems. Each device, supplied by instrument transformers, is an electrical burden; and the transformer is capable of supplying only a limited total burden. PTs typically operate at constant secondary voltage (typically 69 or 120 volts). As devices are added in parallel to the secondary circuit, the burden (current requirement) increases (the load impedance decreases); and, at some point, it will exceed the capacity of the PT.

CTs normally operate at currents that typically range from 0–5 amperes (amps, A). As devices are added in series, the voltage requirements increase (the load impedance increases). At some point, the voltage capacity of the CT will be exceeded.

If the capacity of either a CT or PT is exceeded, the transformer cannot accurately measure current or voltage—especially CTs during a system fault—thus, giving protective relays false information (for PTs, this means its load impedance is less than its stated burden, and for CTs, this means its load impedance is greater than its stated burden). For these cases, a relay may misoperate or not operate at all, endangering the power system, facility, and workers. Therefore, instrument transformers must have their burdens checked and/or measured.

[Instrument transformers, used for protective relaying, must have burdens checked upon commissioning and every 6 years thereafter. In addition, check burdens when adding or replacing any device in the secondary and after equipment or wiring modifications. CT internal resistance also must be measured during commissioning.]

Techniques for calculating and measuring instrument transformer secondary burdens are shown in appendix D, and some measurements can be done with the equipment either in or out of service. CT burden measurements include both the plant wiring and relay circuits. CT internal resistance is not included in the CT burden measurement but is useful for CT accuracy calculations. Field testing for CTs is described in appendix E, and field testing for PTs is described in appendix F.

Burden measurements should not include reactors (inductors) that are found on some relay circuits. Typically, they are on differential relay circuits connected to the relay operate terminal. These reactors are designed to help balance the currents on either side of the differential relay during normal operation, high inrush currents, or external faults with a dc offset waveforms. However, for faults within the differential zone of protection, the resultant current through the reactor quickly saturates the reactor, and it essentially looks like a short circuit (its impedance approaches its dc resistance value). Thus, shorting out the reactor will simulate the burden that the CT will see during faulted conditions.

In many cases, it would be advisable to disable the relay trip output before shorting the reactor to avoid an inadvertent trip.

5.2 Checking Grounds, CT and PT Circuits

[The CT and PT secondary circuits must be grounded at only one point, and secondary grounding must be verified at commissioning, after equipment or wiring modifications, and at least every 6 years.] Verify instrument transformer secondary circuit grounding during design and installation. However, over time due to wiring modifications, insulation deterioration, relay replacement, or instrument transformer replacement, secondary circuit grounds may have been compromised. In addition, grounding practices may have changed since existing systems were installed. Therefore, secondary grounding must be verified on a periodic basis. Verify PT and CT single-point grounding prior to performing insulation, polarity, and phasing tests since multiple grounds could interfere with these test results.

Relay misoperations or failure to operate can be caused by grounding the neutral at two points, such as one ground at the PT or CT and another at the relay panel. The preferred point of grounding for instrument transformers is at the first control board where the signal is used. Spurious grounds may develop, or intentional grounds may be lost as insulation ages and wiring errors occur; therefore, grounds must be checked as described below. See also appendix G, which is excerpted from old FIST 3-23 and is based on the ANSI/IEEE™ Standard C57.13.3. Reference this standard for further information.

To perform this test, the PT or CT primary is de-energized, the intentional ground is removed, and the overall circuits are checked for additional grounds and insulation breakdowns (described in the next section). Any additional grounds must be located and cleared prior to placing the circuit back into service.

5.3 Insulation Resistance Testing for PT and CT Secondaries

[The insulation resistance of PT and CT secondary winding and secondary circuit to ground must be measured upon commissioning, after equipment or

wiring modifications, and at least every 6 years.] While the ground is still removed from checking the grounding points of the circuits (see section above), check the insulation resistance and 1-minute voltage withstand between the secondary circuit of the CT or PT and ground using a standard 500-volt (V) Megger®. Before performing the test, the CT or PT circuit may need to be isolated from the burden/relays, and the primary circuit should be grounded. In the test, include as much of the secondary circuit as possible; but remove the relays and any other burdens from the circuit being tested if it is not known if they can withstand the test voltage. This typically will require lifting leads or opening switches at either the first terminal block in the control panel, the relay test block, the back of the relay, or at the control board fuses for the PT circuits.

Typical values should be much greater than 1 megaohm. Carefully investigate readings lower than 1 megaohm because the insulation integrity may be faulty. See IEEE™ Std. C57.13.1-1981, Guide for Field Testing of Relaying Current Transformers, and IEEE™ Std. C57.13-1993, Standard Requirements for Instrument Transformers.

5.4 Polarity, Phasing, and Connections

[Polarity, phasing, and connection integrity must be verified upon commissioning, whenever instrument transformers or their secondary circuits are modified, and at least every 6 years.]

Correct primary and secondary instrument transformer connections (e.g., wye-delta, delta-wye, wye-wye, etc.) are critical for proper relay operation. Phase angle relationships between voltages and currents are affected by these connections.

5.5 Ratio Tests for Potential and Current Transformers

[Instrument transformer ratio tests must be performed upon commissioning.] Instrument transformers comprise potential and current transformers, which reduce current and voltage to levels useable by protective relays and other control devices. Verify that instrument transformers are operating within their stated accuracy class to ensure the correct operation of protective relays. Relay accuracy classes have been established in ANSI/IEEE™ Std. C57.13-1993.

Instrument transformer ratio accuracy for relaying is not as stringent as for metering transformers. Thus, ratio accuracy tests on relaying transformers generally consist of turns ratio tests and typically are performed by comparing the transformer under test against a transformer with a known ratio, referred to as a reference transformer. Tests typically are performed at rated primary values. However, if test equipment is not available at these high values, it may be necessary to perform ratio tests at reduced primary values. If the turns ratio

exceeds approximately 3 percent (%) of the nameplate ratio, further investigate the accuracy of the transformer. The uncertainty of the test equipment/method used for a turns ratio test should be less than $\pm 1.2\%$ for ratio and 1 degree for phase angle (if used).

For additional information on CT and PT accuracy classes, specifications, and testing, refer to appendices C, D, E, and F.

6. Current Transformer Excitation Tests

[Current transformer excitation tests must be performed upon commissioning and at least every 6 years thereafter.] Excitation tests allow for comparison with published or previously measured data. As with all field testing, it is highly recommended to trend current field data with previous results.

Demagnetize the CT before performing the excitation test(see appendix E). The excitation test is performed by connecting a high voltage alternating current (ac) test source to the secondary of the CT. The primary circuit must be open for the test. The input voltage to the secondary is then varied, and the current drawn by the winding at each selected value of voltage is recorded. Readings located near the knee of the curve are the most important. (See appendix E for more information.) The input current should not exceed twice rated secondary current (e.g., 10 amps for a 5-amp-rated CT) or twice the rated secondary voltage (e.g., 800 V for a C400 CT). The secondary voltage should never exceed 1,500 V.

Investigate any significant deviations from the manufacturer's data or past test results. The excitation current should not exceed the curve tolerance as stated by the manufacturer or, if not stated, 125% of the original curve value. Deviations from the curve may be an indication of turn-to-turn shorts internal to the CT, distortion of the supply test voltage, or the presence of a completed conduction path around the CT core.

7. Danger – High Voltage from Open CT Secondary Circuits

Exercise extreme caution when performing modifications, maintenance, and testing in current transformer secondary circuits.

CAUTION: Current transformer secondary circuits must never be open circuited when the primary is energized.

Current transformers act as constant-current sources to whatever load is applied on the secondary. This means that the voltage changes to provide the same current, no matter what the impedance in the secondary. When the secondary is open circuited, the impedance—and, thus, the voltage—becomes extremely large. This high voltage may destroy the insulation, causing a fault that can destroy the CT, damage other equipment, and be hazardous to personnel. Extreme care must be taken to ensure that a reasonable secondary burden is always present **or** that the CT secondaries have been shorted to prevent high voltages when the primary is energized. Test switches with automatic CT shorting circuits are highly recommended to reduce the risk of opening the secondary. Also, CT shorting bars normally are placed on the CT secondaries by the manufacturer and should be used when CT shorting switches are not available.

8. Plant Protection System Functional Testing

[Protective circuit functional testing, including lockout relay testing, must take place immediately upon installation, every 2 years thereafter, and upon any change in wiring.] If applicable, documentation is required detailing how verified protection segments overlap to ensure there is not a gap when testing the total protection system. The protection circuits include all low-voltage devices and wiring connected to instrument transformer secondaries, telecommunication systems, auxiliary relays and devices, lockout relays, and trip coils of circuit breakers. Protection circuits also may include all indicators, meters, annunciators, and input devices such as governors, exciters, and gate closure control circuits if required for the correct function of the protection system. Although testing of individual components may take place on a regular basis (e.g., relay calibration and lockout relay testing), it is essential to test the entire protection circuit, including wiring, and all connections from “beginning to end” to ensure integrity of the total circuit. Critical examples of these circuits include, but are not limited to, the generator protection (86G), generator differential protection (86GD), transformer differential protection (86KD), and unit breaker failure protection (86JF) circuits. See the block diagram, figure 1.

8.1 Primary and Secondary Injection Test Techniques

One approach to test the total protection system is to use primary injection techniques (see appendix H) that trigger protective relays and lockout relay, trip circuit breakers, and initiate annunciators and indications. This technique also tests the CT or PT ratios, polarity, and phasing. Verify PT and CT secondary grounding in separate tests. If primary injection is not possible, use secondary injection techniques (see appendix H). These techniques locate wiring errors, insulation failures, loose connections, and other problems that go undetected if only relays are tested. Test each part of the entire system at least one time. For example, on a three-phase overcurrent relay, it would be necessary to inject a current at the phase A CT and verify that the relay and associated breaker trip. The phase B and C CT also would need to be tested in a similar manner; but the trip lead from the relay may be lifted, since this part of the circuit already was tested.

8.2 Segmented Test Techniques

Another approach is to divide the individual protection components into segments and to test each segment separately. For example, the PT and CT circuit could be tested and verified from the transformers to the control board test switches. This would verify proper ratios, phasing, and polarity. The relay then could be tested by injecting currents and voltages at the test switch and verifying that the relay trip contact closes. Take extreme care to verify that consistent phasing and

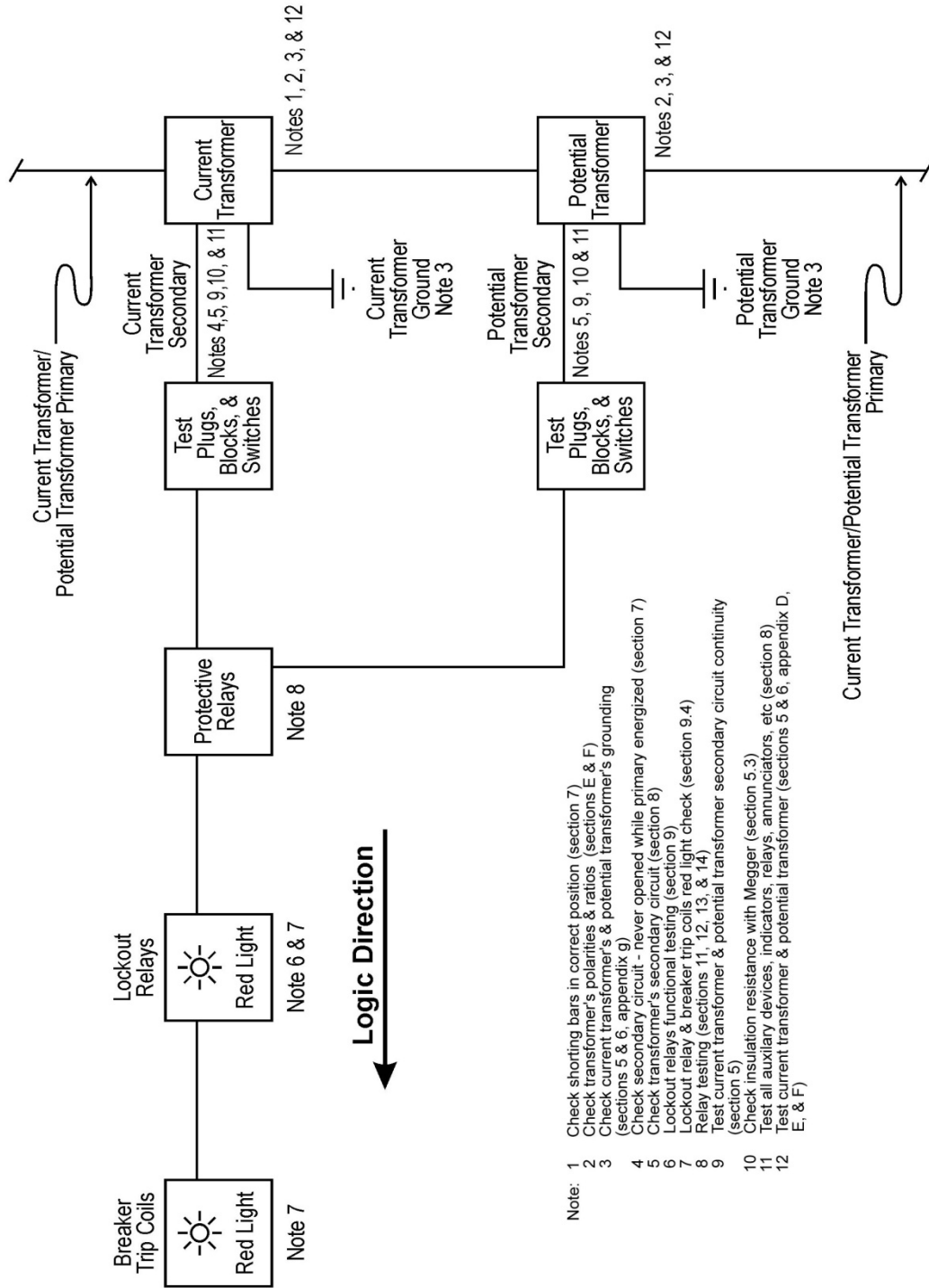

Figure 1. Total plant protection system functional testing block diagram.

polarity are maintained at the test switch between these two tests. Finally, auxiliary relays, the lockout, and breaker circuit could be tested by shorting out the trip leads at the relay. Documentation is required detailing how verified protection segments overlap to ensure there is not a gap when testing the total protection system.

8.3 Online Testing Techniques

The focus of this FIST is on preventive maintenance techniques that are time-based and typically performed using test equipment to insert and/or measure test signals with the powerplant equipment offline. However, many of the tests outlined herein can be performed with the powerplant equipment online. The main advantages of using online test techniques is that it may avoid a powerplant outage and may be a much faster test to perform than an equivalent offline test.

Be very cautious since hazardous conditions may exist when performing online testing techniques. It is inadvisable to perform any test that would require personnel to be exposed to high, primary voltages. Even instrument transformer secondary voltages and currents could be dangerous to personnel, and the proper protective equipment and procedure should be exercised. Opening a secondary CT circuit with equipment online will result in high voltages that will damage equipment and be dangerous to personnel.

Online testing also could cause an inadvertent trip. Some inadvertent trips not only take equipment out of service but also release fire suppression measures such as generator carbon dioxide (CO₂) or transformer water deluge systems. It is critical that, prior to performing any online test, these risks be evaluated and avoided. Test personnel always should remember that they are performing a test and to expect the unexpected. The equipment may not function as designed, and drawings may not be accurate.

All protection system testing, especially online testing, should be designed, peer reviewed, and implemented by qualified staff. Staff must be properly trained, knowledgeable, and experienced in online testing techniques and safety, protection system operations, as well as the facility operations.

CAUTION: Hazardous currents and voltages may be present during online tests.

Current transformer secondary circuits must never be open-circuited when the primary is energized.

Testing could cause the inadvertent trip of plant equipment.

Types of online testing are described below.

8.3.1 Online Functional Tests

Online testing techniques could include a functional test of protection circuits. Using this technique involves activating a protection feature to check if the downstream equipment functions as designed. For example, a relay trip output could be shorted to check if the corresponding lockout, breaker, and indicators function correctly. This type of test will trip plant equipment offline.

8.3.2 Online Measurements

This online test technique involves measuring one or more secondary voltages or currents with the plant equipment running, which eliminates the need for a primary or secondary injection test set. For example, PT or CT ratios and polarity can be verified by comparing the output from one set of instrument transformer to a second set located on the same bus that previously has been tested.

Microprocessor relays can make this test very easy because they typically will display voltage and current magnitudes and phase angles. This test can be performed by simply comparing the displays of two relays connected to two separate PTs and/or CTs.

8.3.3 Post-Event Analysis

The inservice operation of the protection system, when verified, can preclude some required testing. Following an inservice trip event, the performance of the protection system can be evaluated. Microprocessor relays often record the power system waveforms during a system fault. These waveforms can be evaluated to confirm that the relay functioned as desired. In addition, the operations of the protection system from the instrument transformers to the breaker can be evaluated and verified that they also functioned correctly.

8.4 Protection System Failure Modes

It is imperative that instrument transformer secondary circuit integrity be tested on a regular basis. PTs and CTs provide information to protective relays and are subject to several possible failures:

- Failed instrument transformer (shorted or open turns)
- Blown fuse in the primary (PTs only)
- Blown fuse in the secondary (PTs only)
- Open secondary circuit wiring
- Short-circuited CT secondary (e.g., shorted at the shorting blocks at the generator, transformer, exciter, etc., or accidentally shorted in the wiring)
- Incorrect polarities or phasing

- Incorrect wiring
- Insulation failure
- Spurious grounds, loose grounds, or multiple grounds
- Loose connections
- Excessive burdens

Protection system tripping also must be tested on a regular basis and are subject to several possible failures:

- Failed coils (shorted or open turns)
- Incorrect wiring
- Open circuits
- Insulation failure
- Loose connections
- Stuck or tarnished contacts

Any protective device that consists of moving parts may stick in place when not operated for an extended period. This may cause a delay in operation and/or higher operating current. However, once operated, these devices loosen and operate as expected. The implications for testing are:

- It is important to measure the time delay or operating current for the very first operation and compare this value to subsequent operations. A large difference could indicate the device needs more frequent maintenance.
- Frequent testing may help these devices to operate properly when in service.

NOTE: It is important to measure the time delay and/or operating current on the very first test operation of a device with moving parts and to note as such on the test form.

9. Lockout Relays and Lockout Circuit Functional Testing

Lockout relays are among the most important devices in a facility and must be maintained periodically. Failure of a lockout relay to trip protective breakers is known to be the root cause of several large powerplant incidents and has greatly increased the extent of the damage following a system fault. In addition, workers have been injured seriously because of lockout relay failure.

9.1 Possible Lockout Relay Failure Modes

The following is a list of failure modes known to cause protection system failures:

- 1. Wiring installation may twist the relay:** Many lockout relays have more than one stage (sets of contacts) added to the shaft to increase the number of breakers that can be tripped upon relay activation. Most of these relays were installed many years ago and were wired with solid conductors with “square pack” type wiring. These bundles of conductors are bent in perfect 90 squares and laced with waxed twine. These bundles are rigid and can twist the relay as they exit the cover, preventing proper operation of the contacts. This problem can be detected by electrical functional testing (preferred) or manual operation of the relay and closely observing the positions of all contacts. To manually operate the relay, you must remove the cover and manually operate the solenoid armature. The relay cannot be activated from the front of the panel with the handle.
- 2. Crowded wiring may block individual contacts:** On multistaged relays, space for conductors is limited. All wires run along the top and bottom of the contacts, and individual contacts may be impeded when the cover is installed. With the cover off, the contacts may be free and operate properly, so this problem will not be obvious. The only way to detect this problem is to check individual contacts with an ohmmeter from the external terminal before the cover is removed.
- 3. Shaft binding may twist the relay:** On longer relays (several stages), contacts near the handle may operate properly; and contacts further along near the other end can fail to operate. This is due to binding along the shaft and is associated with accumulated dust, dirt, rust, etc. Because the shaft is not perfectly rigid, the shaft may twist a little upon relay activation, causing some contacts to fail to operate. This problem can be detected by manually operating the solenoid armature or, preferably, by electrical functional testing.
- 4. Aged relays and lack of exercise:** When the relay is activated, the shaft is rotated by springs along the shaft. Many of these relays are “original equipment” and may be as old as 70 years. They sit in a “ready” position for many years with the springs tensed. Over time, the springs weaken; and dirt

and rust particles accumulate, partially binding the shaft. When called upon to operate, the springs only “partially rotate” the shaft; and the contacts cannot trip protective breakers. This problem can be detected by manually operating the relay or, preferably, by electrical functional testing.

5. **Failed operating coils:** The relays are electrically activated by energizing a coil usually located on the end of the shaft opposite the handle. If a coil has failed (burned open), the relay cannot be activated to trip protective breakers. Electrical functional tests (preferred) or checking the coil with an ohmmeter will detect this problem.
6. **Wiring errors or activation device failure:** Lockout relays cannot operate if there are wiring errors or if an activation device, such as a differential relay, fails to send a trip signal to the lockout relay. Electrical functional testing will reveal these problems.

9.2 Lockout Relay Maintenance Procedures

[Protective circuit functional testing and lockout relay function testing must take place immediately upon installation and/or upon any change in wiring, upon any misoperation, and every 2 years.] Include the following steps when performing lockout relay maintenance:

- Conduct a job hazard analysis (JHA) and verify that testing will not disrupt normal operation or endanger staff or equipment.
- With lockout relays in the “reset” position, initiate a lockout relay trip with the protective relay contact.³
- The initial functional test must be conducted with the lockout relay in an “as-found” condition to prove that a protective relay action actually will trip the lockout relay and that the lockout will trip circuit breakers or other protective devices (e.g., governor, exciter, etc.). For lockout relays with a removable cover (i.e., Westinghouse type WL and GE type HEA), do not remove the cover prior to performing the initial functional test. This could affect the outcome of the test.
- Visually and/or electrically, verify that the lockout relay actually tripped from the protective relay action. Verify that circuit breakers actually tripped (or other protective action occurred) from the lockout

³ It is recommended that the protective device actually be operated when possible for best assurance. The ideal functional test is to actually change input quantities (e.g., instrument transformer primary or secondary injection) to the protective device to thoroughly test the entire protection path. However, it may be necessary to simulate contact operation with a “jumper” when device activation is not possible.

relay action. Verify that every contact in the lockout relay actually has functioned properly. This may be done visually by removing the cover, checking for proper action of downstream devices, or with an ohmmeter from the relay terminal board.

- Activate the lockout relay from each protective device. After the first full test of the lockout relay and breakers, the lockout relay may be left in the trip position so as not to repeatedly trigger the lockout coil; a meter, light, buzzer, or existing “amber light” may be substituted to verify contact operation.
- Visually check that all alarms, meters, lights, and other indicators have activated.
- Return all devices and wiring back to their normal “ready” positions.
- Perform a timing test on the lockout relays and trend data each time testing is performed.

CAUTION: Do not forget to reconnect the trip bus to the lockout relay when testing is complete.

Where functional testing of EVERY protection circuit is not feasible, such as firing of the CO₂, testing of the most critical protection circuits and devices is mandatory. A variance that documents test details and the reasons why the reduced test is technically sound is required. If design and wiring changes would allow for fully testing the protection system, these changes should be implemented.

If desired, test switches can be installed that permit isolation of inputs and outputs so that the lockout relay can be tested without affecting other devices. Always take extreme care to ensure that test switches are in the proper position for testing (or inadvertent trips will occur) and returned to the normal position when protection is reinstated. Otherwise, protection will be defeated.

CAUTION: Always return test switches to the normal position when protection testing is complete.

Other maintenance procedures for lockout relays with removable covers may include cleaning and lubrication, if required by the manufactures instructions. To clean and lubricate this type of lockout relay, spray all contacts with a nonresidue contact cleaner. Lubricate the moving parts as recommended by the manufacturer with a greaseless spray lube, such as LPS-1, that will not attract dust and dirt.

NOTE: Lockout relays are extremely critical to the safe operation of the plant. It has been found that, due to the constant torque on the relay shafts, they eventually may twist or bind. **Because of this history, it is recommended to consider replacing lockout relays if they are more than 15 years old.**

9.3 Additional Breaker Control Relays and Circuits

Additional breaker control circuitry, such as breaker failure, reclosing, and transfer trip schemes, need to be included as part of the lockout circuit functional testing. These circuits are critical and often function as a second line defense if something was to malfunction with the primary trip circuits. Thus, it is critical to include these circuits when testing the protection system.

Auxiliary relays may be a critical component of protection circuits, and it is important to include these relays when performing functional testing.

9.4 Red and Amber Light Indications/Relay Trip Circuit Monitoring

Lockout relays and circuit breakers perform extremely critical functions—so much so that Reclamation standard designs for lockout relays and circuit breaker control circuits include the use of red (position/coil) status indicator lights or relay trip circuit monitoring. These lights or relay monitor provide continuity check through both the lockout relay coil and breaker trip coil.

[Monitoring of the protection system trip circuits must be performed on a continuous, or near continuous, interval. Visually check red lights for both the lockout relay and circuit breaker coil continuity once per shift in staffed plants and check every time the plant is visited at unstaffed plants. Configure protection relays to continuously monitor lockout relay and breaker trip coil continuity and initiate a plant alarm if a problem is detected.]

At any plant, if breaker or lockout relay systems do not have circuits to monitor lockout relay coils and breaker trip coils, they should be installed as soon as possible.

Figure 2 is an example of a monitoring circuit for a lockout relay. A breaker trip coil monitoring circuit is similar, so only the lockout relay circuit is shown. Both lockout relay and circuit breaker red lights must be “on” (lit) to verify that the lockout relay is ready for an emergency trip, and the breaker trip coil is ready to open the breaker. Figure 2 shows the lockout relay in the “reset” position.

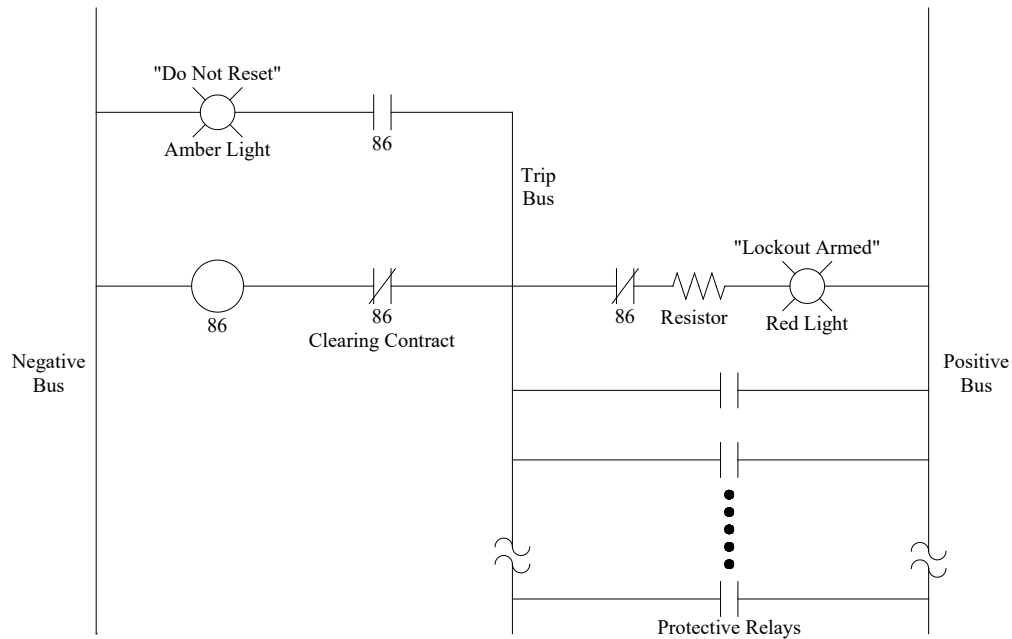

With Lockout (86) reset: Red light indicates 86 coil intact.
Resistor limits current to lockout coil.
Amber lamp is out.

Protective relay trips (86): Red light goes out.
Amber lamp indicates trip bus still energized.

Figure 2. Lockout relay, red light circuit.

NOTE: An example of a lockout relay indicating light circuit is shown in figure 2. A breaker trip coil indicating light circuit is very similar and is not shown.

The red lockout monitor light (i.e., “Lockout Armed” in figure 2) should always be lit when the lockout relay is in the “Reset” position and the trip coil is intact. Likewise, in the breaker control circuit, the red breaker monitor light should always be lit when the breaker is in the closed position and the coil intact. Under normal operating conditions in both circuits, the red light must be lit showing that the lockout relay and breaker trip coils are “armed and ready.”

If the light is not lit, one of three things has occurred:

1. The bulb has burned out. It is recommended that all incandescent lamps be replaced with light emitting diodes (LEDs) due to long life.

If an incandescent lamp is still being used, a “push to test” light socket is needed so that the bulb can be tested anytime it is “out.”

2. The trip coil has failed to open, or the wiring has open circuited.

Trip coils are, by design, underrated so that they will trip quickly. This also means that they will burn out if not de-energized immediately after tripping (thus, a clearing contact is in series with the coil). If the coil has been subjected to being energized for an extended amount of time in the past, the coil may be burned out. A burned-out coil means that the lockout relay or breaker will not trip when required. It is very important to check the lights every day in both the lockout relay and breaker circuits.

3. The lockout relay or breaker actually has tripped, and the “reset” position switch is open. The associated breaker(s) should also have tripped. When a trip actually occurs, the amber “Do Not Reset” light, shown in the previous drawing (figure 2), warns not to reset the lockout relay until the problem is resolved.

If the lockout relay has tripped and the associated breakers have not opened, the lockout-to-breaker circuit has malfunctioned; this must be corrected immediately.

Monitoring these indicating lights is very important. Spare coils and bulbs must be kept on hand. Anytime conditions in 1 or 2 above are encountered, they must be corrected immediately.

Microprocessor relays can be configured to monitor continuously lockout relay and breaker trip coil continuity and can be used in place of the red light check. In the event a problem is detected, the microprocessor relay should be programmed to send an alarm. It is recommended to use this option whenever possible since it increases the reliability of the protection system.

9.5 Protection Circuit Low Voltage Testing

Check breaker trip coils and other devices operated by the relay to ensure that proper operation is obtained at voltages considerably below normal (approximately 56% of normal voltage for breaker trip coils). The value of 56% is 70 volts direct current (Vdc) for a 120-Vdc system. Also check the voltage drop in trip circuits and tripping current.

10. Protection System Drawings

[Drawings associated with protective relays and protection circuits must be up to date and accurate.] Plant drawings are critical for protection system testing, troubleshooting problems, and personnel safety purposes. Update drawings immediately to reflect any changes. Affected drawings include:

Drawing	Information Shown
Single-line diagram	Protective relays used in the application
Three-line diagram	Schematic representation of instrument transformer connections to relays
Protection schematic	Protective relay – lockout relay scheme
Tripping block diagram	Simplified representation of tripping scheme
Wiring diagrams	Detailed connections of protection system devices
Logic diagrams (Microprocessor based relays)	Detailed connections internal to the protective relay; changes are made with the programming of the relay

Protective relaying and protection system components must be represented on the drawings using consistent nomenclature to reduce confusion. Where possible, relaying and protection nomenclature should conform to typical drawing 104-D-1150, Device Designations and Symbols To Be Used on Single-Line and Schematic Diagrams, which conforms to IEEE™ Std. C37.2. See appendix B for device numbers and explanations.

11. Testing Equipment and Software

A high-quality relay test set and tools are important to test protective relays in an accurate and repeatable manner. Troubleshooting of microprocessor-based relays also may require specialized equipment, a laptop computer, communication cables, and software. Check manufacturer's recommendations for necessary tools and equipment. If not available at the facility, most test equipment and tools can be borrowed from 86-68440, the Relay Users Group, at 303-445-2300. Testing assistance is also available from this group.

Microprocessor relay testing can be automated. These relays can be tested with computer-based software that communicates with both the relay and the test set. It is preferable to test relays using automated testing procedures to reduce the time required and increase reliability and repeatability of tests being performed. However, it is critical that the person responsible for relay testing have a thorough understanding of the relays, external protective circuits, and all test procedures. All automated testing procedures must be validated by a qualified person before using them to test relays. Due to the critical nature of protective relays and enormous prohibitive cost of a failure-to-trip or false trip, only a thoroughly trained, experienced person should perform and/or oversee these tests.

In conjunction with automated relay testing software, relay specific software may be used to check relay operation. Most relay manufacturers have proprietary software, which is used as a human-machine interface (HMI). Using the HMI allows the technician to view, download, and change relay settings; view relay inputs and outputs; and download sequence of events from the relay. Always remember that an HMI user can change settings using this software; it is imperative that no settings are changed inadvertently or without approval. While it may not be necessary to use an HMI while testing a relay, it can be a valuable tool to assist in troubleshooting relay operations.

Reclamation owns corporate licenses on many different types of relay software programs, such as the SEL – 5010 Relay Assistant and SEL – 5601 Analytic Assistant from Schweitzer Engineering Laboratories, Inc. Reclamation-licensed software is available on the Reclamation Users Group Web site at <http://intra.usbr.gov/~hydrores/relaytest/index.htm>. Reclamation users may download and use many software packages from this site at no cost.

Reclamation also owns a corporate software license for RTS by Enoserv. RTS may be used to automate relay testing procedures for solid-state, electromechanical, and microprocessor-based relays. A software key (dongle) is required for this package and may be purchased from the manufacturer. Once a key is purchased, facilities may obtain support and upgrades from both the Relay Users Group and directly from Enoserv. This software package is used for automated relay testing and communicates with relays and relay test sets available from numerous manufacturers. For more information, contact the Relay Users Group at 303-445-2300 or by email at relay_help@usbr.gov.

11.1 Online Relay Testing Precautions

To preclude inadvertent trips, before starting any relay test with protected equipment in service, testing personnel must be familiar with relays and associated circuits. Test personnel must consult with the manufacturer's recommendation on the proper method/sequence to open relay tests switches. Typically, the relay outputs are opened first to block subsequent relay trip signals. The power and instrument transformer inputs then are opened prior to testing.

When test blocks are used, ensure that removing or inserting plugs will not open a CT secondary. Opening a secondary with the primary energized will result in high voltage, which can destroy the CT or other equipment, be dangerous to personnel, and/or cause an inadvertent trip. If test blocks are not available, before the relay CT circuit is opened, CTs must be shorted by the shorting blocks provided by the manufacturer or by shorting switches.

Before removing any relay from service, be very cautious; the unit may need to shut down for relay testing, or the unit may have redundant protection and can continue to operate during testing. Typically, it is advisable not to allow equipment protected by a relay to operate without appropriate relay protection while testing.

CAUTION: Removing a relay for testing often reduces or eliminates the protection of the associated plant equipment. A thorough review of the equipment protection scheme and the associated risks of removing the relay with the equipment in service must be evaluated prior to relay testing. Often, it is necessary for equipment to be removed from service during relay testing.

11.2 Records

Maintain records of protection system preventive maintenance and testing in CARMA. The RRIS database, mentioned in previous sections, is designed to store information regarding CTs and PTs, as well as relay information. This database should be updated by each facility, installing the latest information regarding new equipment and testing data.

A complete record must be kept of test data “as-found and as-left” and of the observations made during tests and inspections, including brands and serial numbers of test equipment used. Record this information in CARMA and in the RRIS database. Testing information also should contain the following:

- Region
- Area office

- Plant location
- Unit/equipment
- Device identification
- Circuitry
- Tested by
- Date of test
- Device manufacturer
- Device type
- Model/style
- Serial number
- IEEE™ device
- Installation date

The following relay test report forms are available on the Reclamation Intranet at intra.usbr.gov/forms. After this page appears, click on “PO&M Forms.”

Form No.

PO&M 100 – Overcurrent relay test report

PO&M 101 – Differential relay test report

PO&M 102A – Distance relay test report (Westinghouse)

PO&M 102B – Distance relay test report (General Electric)

PO&M 106 – Miscellaneous test sheet

11.3 Record Retention

[Records of verification for a particular protections system test, at the very minimum, must include the most recent test records, the second most recent test records, and all test records of tests performed within the last 6 years.]

Preferably, keep the records for the life of the equipment being tested to allow comparison of present and past test results.

NOTE: Other Reclamation guidelines, such as the Information Management Handbook, may require longer retention periods.

Records consist of such items as completed work orders that contain documented test results, RTS generated reports, hand-written testing documentation, test report forms, or data entered into CARMA.

12. Electromechanical Relay Calibration Procedures

NOTE: It is recommended that electromechanical relays be replaced by microprocessor relays due to their age and more rigorous test cycle requirements. Experience has shown that microprocessor relays are more dependable and require much less maintenance. One microprocessor relay can replace several electromechanical relays and are self-diagnostic.

Many electromechanical relays have been replaced by solid-state or microprocessor-type relays. However, numerous electromechanical relays remain. Because of the nature of these relays, components age, and settings drift, frequent calibration is necessary.

12.1 Frequency of Testing

[Electromechanical relays must be calibrated upon commissioning, after 1 year of service, and at least every 2 years thereafter. Relays in harsh conditions must be calibrated annually. Relays also must be calibrated after setting changes or repairs.] Harsh conditions are defined as relays subject to vibration, dusty atmospheres, and extreme temperature changes.

12.2 Commissioning and Maintenance Visual Checks

Before placing new equipment into operation, polarity of instrument transformers, relays themselves, and all associated wiring must be checked. In some cases, manufacturer's polarity markings are found to be incorrect. New relays must be inspected carefully; and all blocking put in by the manufacturer must be removed. Testing personnel should read the manufacturer's instruction manuals to become familiar with construction and operation of the relays.

Follow the initial "as-found" test as described in section 12.3.a. Make visual maintenance checks by manually operating relay contacts to ensure all devices operated by the relay function freely and properly, including auxiliary contacts and targets within the relay. Check breaker trip coils and other devices operated by the relay to ensure that proper operation is obtained.

A visual inspection should be made of all relays, including tripping auxiliaries and accessories. Drawout type relays should be withdrawn for a closeup examination. All other relays, including auxiliaries, should have covers removed and be visually inspected. Always check for loose connections, broken studs, burned insulation, and dirty contacts. Check each relay for proper settings. On some relays, including distance relays, it may have been necessary to reset the taps or dials to other than specified values to calibrate properly. If taps or dials

are found on unspecified settings, check the prior calibration test report. Always test a relay to the documented setting and not the setting indicated on a tap or dial.

A test trip should be made of all relays. Check each element that initiates protective functions.

12.3 Electromechanical Relay Maintenance Test Procedures

Tests to be performed during routine maintenance are determined by the type of relay to be tested. Include the following tests and procedures for all electromechanical relays:

- a. **An initial “as-found” test** of all disk-type relays should be performed before the relay has been disturbed, such as withdrawing it from its case. Perform the initial as-found tests in the same manner as a timing test, if appropriate. This is critical for electromechanical disk-type relays to ensure that they would have detected abnormal conditions prior to being disturbed and on the first application of test current.

EXAMPLE: On an overcurrent relay, test at two times (2 X) pickup to verify correct time delay and verify that the disk is free to rotate.

Make notes on the test record as to the nonstandard “as-found” condition of the relay.

- b. **Mechanical adjustments and inspection** should be made according to the following instructions:
 - (1) Check to see that all connections are tight. Loose connections could indicate excessive vibration that must be corrected. Check to ensure that rotating discs rotate freely.
 - (2) All gaps must be checked to ensure that they are free of foreign material. If foreign material is found, check the case gasket and replace it, if necessary. If the relay has a rotating disc, be careful to check for foreign material between the magnets and rotating disc, especially under the disc. Bits of magnetic material, rust, and dirt between the disc and magnet will impede disc rotation and must be removed.
 - (3) All contact or armature gaps must be inspected. Large variations in the same type relay may indicate excessive wear. An adjusting screw could have worked loose and must be tightened. Note all of this information on the test record.

- (4) When specified in the manufacturer's instruction manual, contacts can be burnished with a burnishing tool. Note that a burnishing tool has a very fine abrasive for cleaning dirt and oxidation off contacts. Never touch a relay contact with sandpaper or a file; the contact will be destroyed. Measure contacts for alignment and wipe, according to the manufacturer's instruction manual.
- (5) Checking bearings or pivots usually involves dismantling the relay. It is recommended that these tests be performed only when the relay appears to be extremely dirty or when electrical tests indicate undue friction.

c. Electrical tests and adjustments

- (1) **Contact function.** Manually close or open the contacts and observe that they perform their required function.
- (2) **Pickup.** Pickup is defined as that value of current or voltage that will "just close" the relay contacts. Gradually apply current or voltage to see that the pickup is within limits. The current or voltage must be applied gradually to yield data that can be compared with previous or future tests and not be clouded by such effects as transient overreach. If current pickup value exceeded the relays continuous rating, pulse the current to avoid overheating the relay current elements.
- (3) **Dropout or reset.** To test for excessive friction, reduce current or voltage until the relay resets. Observe the armature or disc movement. If the relay is slow to reset or fails to reset, the jewel bearing and pivot must be examined. A four-power magnifying glass is needed for examining the pivot. The jewel bearing can be examined by moving a needle across the surface, which will reveal any cracks. If dirt is found, the jewel can be cleaned with an orange stick, and the pivot can be wiped clean with a soft, lint-free cloth.

NOTE: An orange stick is a small "flat sharpened" stick that, historically, was made from the wood of an orange tree. Today, the stick typically is made from birch; however, it is still called an "orange stick." This tool normally is used for manicures and may be obtained from a beauty or nail salon.

No lubricant should ever be used on the jewel or pivot.

d. Blocking of relay contacts

If the relay test requires the blocking of trip contacts, the blocking material must be removed after testing. Failing to remove the blocking material could lead to an inadvertent trip or failure of the relay to operate. A common practice utilized by relay test personnel is to use a \$20 bill

or larger, when blocking contacts open or close. This will ensure the blocking material is not forgotten in the relay.

e. Document results

Record observations test notes and test results on the proper forms in CARMA and/or the RRIS database.

If possible, always test relays “in the case” to duplicate “inservice” conditions. The relay case acts as a shunt for stray flux that travels outside the electromagnetic iron circuit due to saturation. If tested out of the case, the results may not match published curves. If it is impractical to test the relay in its case, it must be noted on the test report. Differing test conditions, such as being near a steel cabinet or working on a steel bench, will change results if the relay is tested out of the case.

12.4 Auxiliary Relays

In addition to tests described above, auxiliary relays employing devices for time delay (for example, capacitors or air bellows) should have an operating time test performed (either pickup or dropout, whichever is applicable). Plotting current and voltage at the coil terminals during pickup provides information that can be compared to previous data.

12.5 Time-Overcurrent and Time-Overvoltage Relays

All tests described above must be performed for time-overcurrent and time-over-voltage relays. Perform an initial “as-found” test prior to disturbing the relay, such as withdrawing it from its case for visual checks. The next relay test should be a pickup test. This value should be within the manufacturer’s specifications (typically, $\pm 5\%$).

Testing current levels at three points on the time-current curve generally is sufficient for maintenance purposes. Always use the same points for comparison with previous tests. These values should be within the manufacturer’s specifications (typically, $\pm 5\%$). Very fast operate times (in the 1- to 15-cycle range) can have larger errors because the fixed time error becomes larger than the slope error. Check manufacturer’s specifications or pick a test point with a longer operate time.

Check the instantaneous trip unit for pickup using gradually applied current. Whenever possible, apply the current only to the instantaneous coil to avoid overheating the time coil. If necessary to apply to both coils, the instantaneous current should be applied in short pulses.

Also test the target seal-in using gradually applied direct current. The main contacts must be blocked closed for this test.

12.6 Directional Overcurrent Relays

In addition to tests recommended for the overcurrent relay, test the directional portion of the directional overcurrent relay for minimum pickup, maximum torque angle (MTA), contact gap, and clutch pressure. Also, check that the overcurrent portion operates only when the directional unit contacts are closed.

12.7 Distance Relays

When testing distance relays, conduct tests for pickup, MTA, contact gap, and clutch pressure, in addition to the applicable tests described above. (See appendix I for testing and adjusting Westinghouse Type KD relays.)

12.8 Differential Relays

Perform a test of minimum pickup for differential relays. Check the differential characteristic (slope) with at least two points; and where applicable, test the harmonic restraint.

Differential relays using ultrasensitive polarized sensing devices are slightly affected by previous history, such as heavy internal or external fault currents. Therefore, for this type relay, take two pickup readings and use the second reading for recording and comparing with previous and future tests.

CAUTION: Take extreme care to ensure that shorting a CT will not cause an inadvertent trip or loss of protection elsewhere in the system. Shorting one CT in a differential relaying scheme with the system energized will definitely cause an inadvertent trip. Follow manufacturer's recommendation/procedure when disabling relay CT inputs.

12.9 Temperature Relays and Resistance Temperature Devices

Check the temperature "bulb type" relays used on bearings and other installations. Various manufacturers offer specialized test sets with a built-in heater and temperature indicator designed to test temperature devices. If a test set is not available, temperature relays can be tested by placing the bulb in a container of water with a thermometer and gradually heating the water to the temperature at which the relay is set to operate. As the temperature rises, the water should be stirred, and the thermometer should be used to read the temperature. Record the temperature at which the relay operates on increasing temperature and at which it resets on falling temperature.

Resistance temperature devices (RTDs) and thermocouple type temperature relays can be tested using a handheld temperature calibration meter. These meters simulate the RTDs or thermocouple device for input into the relay. The type of RTD (10 ohms [Ω] copper or 100 Ω platinum) or the type of thermocouple (type J, K, or T) must be known for these calibration meters to work. A variable resistor also can be used to calibrate RTD relays. The resistance value can be converted to a temperature per RTD conversion tables that are readily available on the Internet.

RTDs generally are extremely accurate; and when they fail, it is very obvious—it either works or it doesn't. It normally is not necessary to test them. If a test is needed for a faulty RTD, devices are available for testing RTDs that have a heater and temperature indicator built in, or they may be checked by heating them slowly in an enclosed air space with a thermometer. RTDs should not be immersed in water or other liquid unless they are rated for immersion.

Embedded RTDs (such as in the stator) can be checked by comparing the readings of various RTDs at room temperature. They also can be checked at elevated temperatures by comparing readings of various RTDs after a unit is taken offline and the temperature equalizes throughout the unit while it cools down.

12.10 Pressure Relays

Check pressure relays for correct operation by comparing with an accurate pressure gauge or manometer. Pressure should be increased slowly and decreased to determine the pressure at which the relay operates and resets.

12.11 Sudden Pressure and Buchholz Relays

This FIST does not apply to sudden pressure and Buchholz relays on transformers, which should be maintained according to the manufacturer's recommendations. See FIST 3-30 and 3-31 for sudden pressure and Buchholz relay testing.

13. Solid-State Relays

NOTE: It is recommended that solid-state relays be replaced by microprocessor relays due to their age and more rigorous test cycle requirements. Experience has shown that microprocessor relays are more dependable and require much less maintenance. One microprocessor relay can replace several solid-state relays and are self-diagnostic.

Many solid-state relays have been replaced by microprocessor-type relays. However, numerous solid-state relays remain. Because of the nature of these relays, components failure, and settings drift, frequent calibration is necessary.

13.1 Frequency of Testing

[Solid-state relays must be calibrated and function tested upon commissioning, 1 year after commissioning, and every 2 years thereafter. Relays also must be calibrated and function tested after setting changes or repairs.]

Solid-state (analog type) relays are in service in many applications. Settings typically do not drift as much as those in electromechanical relays and are less affected by dirt, vibration, humidity, and other environmental concerns. They require less current, have a higher seismic-withstand, and require less panel space. These relays also have fewer moving parts and require less maintenance compared to electromechanical relays. However, they differ from electromechanical relays in that electronic component failure can render the relay ineffective, and this condition can go undetected. Frequent testing is required to discover these hidden failures and to adjust settings that have drifted.

13.2 Testing Requirements

Solid-state relays must be tested according to the manufacturer's recommendations. There are no moving parts, no physical wear, and no need for lubricants. Prime causes of failure in electronic components are power supplies, over or under voltages, voltage transients, current surges, heat, age, vibration, and moisture. Overheating can be caused by voltage transients, current surges, or high ambient temperature. Vibration can loosen or break leads and connections and can crack component casings, circuit boards, and insulation, resulting in equipment failure. Moisture can result in corrosion and oxidation of metallic elements, which can result in circuit discontinuities, poor contacts, and short circuits. Direct preventive maintenance of solid-state relays toward removing causes of failure listed above by the following actions:

- Check the supply voltage and the power supply output voltage.
- Keep equipment clean by periodically vacuuming or blowing out dirt, dust, and other contaminants. Dust may be blown out with “dry canned air.” Do not use plant air or an air compressor due to contaminants, moisture, and static buildup.
- Keep the equipment dry and protected against moisture and corrosion.
- Inspect to see that all connections, leads, and contacts are tight and as free as possible from effects of vibration.
- Check to see that there is adequate ventilation to conduct heat away from the relay.

Preventive measures should not be applied unnecessarily since this may contribute to failures. For example, do not pull printed circuit cards from their racks to be inspected if there is no real need. Operating test switches unnecessarily may introduce damaging voltage transients.

13.3 Commissioning and Maintenance Visual Checks

Before placing a new installation into operation, check polarity of instrument transformers, relays themselves, and all associated wiring. In some cases, the manufacturer’s polarity marking may be found to be incorrect. Carefully inspect new relays, and remove all blocking/packing put in by the manufacturer for shipment. Testing personnel should read the manufacturer’s instruction manuals to become familiar with the construction and operation of relays.

Perform visual maintenance checks by manually operating relay contacts, if possible, to make sure all devices, operated by the relay, function freely and properly, including auxiliary contacts and targets within the relay. On solid-state relays, manufacturers may include a test switch on the relay front. Breaker trip coils and other devices operated by the relay must be checked to see that proper operation is obtained.

13.4 Calibration and Testing Techniques

Calibration of protective relays should take place at the power facility by qualified and trained personnel. A firm understanding of electronics is required for repair or troubleshooting these relays. Avoid transporting relays to a remote location for testing, since this introduces the possibility of damage to relays or changed settings from vibration or rough handling.

Calibration of solid-state relays requires a technician to adjust potentiometers, variable capacitors, or variable inductors to ensure correct operation. Eliminating a majority of moving parts within solid-state relays (versus electromechanical) has allowed easier and more precise adjustments to be made. However, solid-state relays are inherently sensitive to voltage transients and current surges. When calibrating solid-state relays, take the following precautions to avoid static discharge damaging the relay:

- Work on a grounded, semiconductive mat or other suitable static protection system.
- Always touch a grounded metal surface before touching circuit boards, especially when relays are equipped with metal-oxide semiconductors.
- Always try to use a differential input mode for measuring instruments when troubleshooting circuits to avoid introduction of ground loops.

It is important to remove the relay case test plug (per manufacturer's recommended procedure) from a relay before changing tap settings on the CT or in the relay itself. Removing the test plug will power down the relay, short CTs, and ensure that trip contacts remain in the correct position, reducing the risk of inadvertently tripping the equipment offline. This also will ensure that CT secondary circuits are not opened during the tap change, alleviating the risk of high voltage destroying the CT and/or the relay.

Refer to the manufacturer's instruction manuals before performing insulation resistance tests on these relays. If the manufacturer's information is not available, it is not recommended to perform this test on solid-state relays. While individual components may withstand test voltage levels, applying high dc voltages may introduce voltage spikes that could damage the relay.

If a circuit card must be removed for repair, cleaning, or maintenance, use extreme care removing and re-installing the card. Never force a board into place or bend it. If circuit cards must be removed, first touch a grounded metal frame. If circuit board contacts appear dirty, clean as needed. Before attempting to disassemble the relay, refer to the manufacturer's instructions.

Ensure that the relay case is grounded as recommend by the manufacturer. Ensure that all required grounds are in place before testing or placing a relay into service.

13.5 Testing Procedures

a. Mechanical inspection:

- (1) Check to see that connections are tight. Loose connections may indicate excessive vibration that must be corrected.
 - (2) The relay must be examined for excessive debris. Debris can cause an inadvertent path to ground, causing the relay to trip or be damaged. Debris can be removed by using canned air, available at most electronics stores. Never use an air compressor or plant air to remove debris due to possible static electricity and moisture.
- b. Electrical tests and adjustments:
- (1) Using a digital multimeter, check the input voltage to the relay. If the relay has a dual power supply, ensure jumpers are in the correct position to provide the correct voltage.
 - (2) If so equipped, use the test function switch on the relay to ensure that all indicators are working correctly. Also, exercise the reset to ensure that this function is working.
- c. Functional testing:
- (1) **Pickup.** Gradually apply current or voltage to see that pickup is within limits. Gradually apply current or voltage to yield data that can be compared with previous or future tests.
 - (2) For timing tests, it is important to test the relay at multiple points on the timing curve. If a relay does not operate within given specifications, it may be necessary to adjust the relay. Typically, solid-state relays will allow the user to adjust components such as potentiometers, variable capacitors, or variable inductors. However, dual in-line package (DIP) switches may also affect settings internal to the relay. Refer to the instruction manual for further details.
 - (3) For voltage, frequency, and current tests, it may be possible to test the relay at one or more points on its operating curve. Relay adjustment can be handled in the same manner as timing tests.
 - (4) Many of the procedures for testing solid-state relays are the same as for testing electromechanical relays. For further information, the technician should read the section on electromechanical relays along with the relay specific instruction manual.

14. Microprocessor (Digital) Relays

Microprocessor (computer-based) digital relays are replacing electromechanical and solid-state relays in many applications. It is recommended that electromechanical and solid-state relays be replaced by digital relays as systems are upgraded. Microprocessor relays have several advantages, such as:

- Can take the place of several electromechanical or solid-state relays.
- Can detect conditions that other types of relays cannot.
- Have settings that are software-based and do not drift with time, ambient temperature, supply voltage changes, or aging.
- Can log input data and output data to other devices.
- Have built-in redundancy.
- Can log sequence of events for trouble shooting in case of faults.
- Are self-testing and self-diagnostic.
- Have extremely fast operating times.

A microprocessor relay is defined as a relay that samples the voltage or current waveform, converts these samples to a numeric value for calculations, and performs self-diagnostics. Relays that use analog circuits for comparisons or calculations in addition to a microprocessor for timing or logic are considered solid-state relays.

14.1 Testing Precautions

To preclude inadvertent trips, before starting any relay test with protected equipment in service, testing personnel must become familiar with relays and associated circuits. When test blocks are used, ensure that removing or inserting plugs will not open a current transformer, resulting in high voltage that may be dangerous to personnel, damage the CT or other equipment, or cause an inadvertent trip. In installations where test blocks are not available, before the relay current circuit is opened, CT circuits must be shorted by shorting blocks or shorting switches.

Removing a digital microprocessor relay from service will remove all its protective functions. Take extreme care to ensure that equipment left in service is protected adequately during testing. Do not allow equipment to operate without relay protection while relays are being tested.

CAUTION: Take extreme care to ensure that shorting a CT will not cause an inadvertent trip or loss of protection elsewhere in the system. Shorting one CT in a differential relaying scheme with the system energized will definitely cause an inadvertent trip. Follow the manufacturer's recommendation/procedure when disabling relay CT inputs.

14.2 Frequency of Testing

[Microprocessor-based relays must be function tested upon commissioning, 1 year after commissioning, and every 4 years thereafter for unmonitored relays and 6 years thereafter for monitored relays. Relay analog and digital inputs and outputs should be checked upon commissioning, 1 year after commissioning, and every 2 years thereafter. Relays also must be functional tested after setting changes, repairs, or firmware updates.]

14.3 Commissioning and Maintenance Visual Checks

Before placing a new installation into operation, polarity of instrument transformers, relays themselves, and all associated wiring must be checked. In some cases, a manufacturer's polarity marking may be incorrect. Carefully inspect new relays for physical damage that may have occurred during shipment. Testing personnel should read the manufacturer's instruction manuals to become familiar with the construction and operation of the specific relay. All functions are programmed into the relay, typically using a laptop computer and related software. Testing personnel should read the manufacturer's software manuals and become familiar with the software operation.

Make maintenance visual checks by manually operating relay outputs to ensure all devices operated by the relay function properly. On microprocessor-based relays, typically, it is necessary to operate the relay using a computer connected to the relay and inputting specific commands that will test each function. It may be possible to test functions without using a computer, but this can be much more difficult and time consuming. Refer to the instruction manual for recommendations regarding manually tripping the relay. During functional testing, logic within the relay is also tested. When energized, many digital relays will display voltage and current input values as well as phase angle information. This information can be used to verify proper phasing and polarity of these inputs.

One microprocessor-based relay may replace five, ten, or more electromechanical or solid-state relays. Each of these functions within the relay must be tested to ensure they all operate as designed. Breaker trip coils and other devices operated by the relay must be checked to see that proper operation is obtained.

14.4 Functional Testing Techniques

Typically, calibration of microprocessor relays is not required and not possible. The relay is operated by a microprocessor that is programmed to operate in a manner similar to electromechanical or solid-state relays. There are no user-adjustable components in the relay. If a relay does not pass a specific test, often the test point mismatches the relay settings. If the relay tests continue to fail, then examine the relay test procedures to ensure that the relay and test set are correctly configured. If everything is proven to be correct, the relay may need to be repaired or replaced; contact the relay manufacturer for additional guidance.

In the past, electromechanical relays were used throughout Reclamation; and each relay served as one protective element. With microprocessor-based relays, the technician is not able to see the relay “operate” because there are no moving parts. All functions are programmed into the relay using a laptop computer and related software. The software emulates electromechanical relay operation—thus, it is important to have a good background in relay theory and experience and knowledge in using relay testing software before testing these relays.

14.5 Relay Functional Testing

Each microprocessor relay must be tested functionally per the test schedule stated above, preferably with inservice settings. Protective relay functional testing includes operating the relay in place or on a bench to verify that:

- The settings are correct (note any differences).
- The appropriate output contacts close/open at the proper time and under the appropriate inputs.
- Analog and digital outputs are accurate and reliable.
- Indicating devices, such as targets or indicating lights, operate correctly.
- Logic functions operate as designed.

Steady-state functional testing of microprocessor-based relays typically is performed using a laptop computer, or they may be networked together via Ethernet local area networks (LANs) to a personal computer (PC) for testing and monitoring. Steady-state testing is a process where each element of a relay is tested individually, one element at a time. As microprocessor-based relays typically encompass several protection elements, it is often necessary to “isolate” a particular function to test it. This is accomplished by routing the digital element output under test to an unused physical output. Another method is temporarily to disable any overlapping or interfering relay functions via software when they interfere with the element test.

Making changes to the inservice “as-found” settings for testing requires that the original settings be re-entered back into the relay after testing. It is highly recommended to download a copy of the as-found settings to a secure location before testing. Save a backup copy of the official settings to a memory stick, hard disk, or other form of media to ensure that settings can be restored.

It is important to compare the as-found settings in the relay with the official settings that should be in the relay and to document any discrepancies. After testing is complete, if the as-found copy has all the correct settings, reload these settings back into the relay from the saved copy. This typically is easier than trying to reverse all the changes. Reconfirmation (manually or automatic) that the settings entered into the relay match the official setting is required (see section 14.9). Most manufacturers’ software allows a user to compare settings in the relay to settings on the disk; this alleviates the possibility of file corruption during downloads and ensures that the official settings match the as-left settings.

Test each enabled element of a relay to ensure settings are correct and the relay is operating properly. If a relay element is not enabled, it does not need to be tested. Relay elements that do not lead to a trip or alarm do not need to be tested.

Following a setting change, functional testing of microprocessor-based relays can be limited to a functional check of the affected element if the change is limited in scope, such as a change of a variable(s) (a pickup value, a time value, or curve type) and all the settings are verified correct following the setting change and functional test. Documentation of the technically sound rationale to limit the functional test is required. Functional testing of the entire relay is required if changes involve a firmware update, repair, enabling or disabling a relay function or element, logic changes, or a change that effects multiple functions or elements.

14.6 Unmonitored/Monitored Relays

Most microprocessor relays are self-testing and self-diagnostic. They monitor their internal programming and can alarm if and when an internal error is detected. Monitoring a relay is highly recommended since it increases reliability and reduces maintenance by increasing the required relay function test interval. A microprocessor relay is considered unmonitored unless relay monitoring meets all the following requirements:

- Real time relay monitoring and alarm of internal self-monitoring system
Example: Relay self-check function wired to annunciator
- Real time relay monitoring and alarm of dc supply or power supply failure
Example: Use of a normally closed contact to alarm on loss of power.

- Plant or relay monitoring of trip coil continuity (either real time or via red light check interval)

Example: See section 9.4.

- If applicable, monitoring of protection telecommunication system (real time or periodically per test interval)

Example: Alarm if communication link is interrupted.

- Plant monitoring of dc battery voltage (real time or per test interval)

Example: 27 relay on dc bus.

- Verification of relay inputs and outputs (real time or per test interval)

Example: Calibrate relay inputs and check outputs, per section 14.7.

14.7 Relay Input/Output Function Testing

As mentioned above, microprocessor relays are self-monitoring; however, microprocessor relays cannot monitor their analog or digital input or output circuitry. Thus, it is necessary to test digital relay inputs and outputs functionally upon commissioning, 1 year after commissioning, and every 2 years thereafter.

Digital and analog inputs and outputs must be tested to verify functionality. Only the inputs and outputs that are in use need to be tested. If a relay input or output is not enabled, it does not need to be tested. However, if and when a relay input or output is enabled or disabled, the entire relay should be function tested at that time, independent of the testing schedule. In most relay applications, only the analog current and/or voltage inputs and one or two digital outputs are enabled.

Analog inputs (voltages and currents) can be tested offline by comparison to a calibrated set of inputs. The relay test set can be used for these tests. The analog inputs also can be checked online manually by comparing the meter display values to a second digital relay or metering device connected to the same primary circuit. This test can be automated by using a condition monitoring system continuously to perform this test. The accuracy of the relay values must be within manufacturer specifications.

The digital output test can be performed by connecting the relay to a PC and forcing the output to change state. The relay also can be programmed to use an unused digital input to trip the outputs. An external signal then can be connected manually to this input to function check the output circuit. This test can be combined with the protective system trip tests (see sections 8 and 9), or it will be

necessary to lift the relay trip lead to avoid unintentionally operating the plant protective devices.

CAUTION: Take extreme care to ensure that equipment left in service is protected adequately during testing. Do not allow plant equipment to operate without relay protection while relays are being tested.

14.8 Testing Programmable Logic

The programmable logic within a microprocessor-based relay allows the relay to act as numerous different electromechanical relays. Treat the programmable logic the same as control wiring. Produce and document logic diagrams on drawings. These drawings should be available during function testing relays or troubleshooting. Testing of the programmable logic must be considered as important as functional testing traditional schemes.

Test the logic in the same manner as functional elements of electromechanical relays. This means all inputs, outputs, relay function blocks, controls, alarms, and switches perform as intended and do not operate with unintended consequences. Logic settings must be reviewed and tested anytime settings that could affect the logic are changed. Drawings must be updated at this time. It is essential to keep a set of “as-built” relay logic settings and drawings at the facility. A hard copy of relay settings and logic is useful in case there is a situation where a computer is not available to communicate with the relay.

14.9 Communication Equipment Used in Conjunction with Protective Relaying

It is critical to perform testing on the protection system communications equipment if the protection system is so equipped. This includes protection system telecommunication equipment and channels required for correct operation of the protection system. It also includes testing equipment used to both convey remote tripping action or blocking signal to the trip logic. **[Unmonitored protection system communication requires testing upon commissioning, 0.25 years thereafter, and after equipment or wiring modifications. Monitored protection system communication requires testing upon commissioning, 6 years thereafter, and after equipment or wiring modifications.]**

A communication system is considered unmonitored unless monitoring and alarming of the function of the communication system is performed by such means as continuous built-in self-monitoring or periodic checkback tests, guard signals, or channel messaging functional indication. Real time monitoring of the communication alarm signal also is required.

Proper implementation requires a well-defined and coordinated test plan for performance evaluation of the overall system during the required maintenance intervals. Testing should be performed from the bottom up, beginning at the component level and continued until the overall system is tested. The employees performing the tests need to have full knowledge of the intent of the scheme, isolation points, simulation scenarios, and restoration to normal procedures. Often, this may include coordination with other organizations, such as transmission owners and operators, to ensure that the communication system is fully tested. Testing the system will verify the overall performance of the communication schemes, including logic, signal quality, and overall performance to validate the protection scheme performance.

During the initial commissioning or following major modifications, it is critical to verify that the system operates as designed. The commissioning test also is vital to establish a benchmark of field performance to which future tests will be compared. Verification of the communication system may involve checking signal levels, signal to noise ratios, or data error rates. While performing these tests, lost packet count should be monitored, if available. Lost packet count can be a good indication of channel health. Packets typically are lost due to corruption caused by noise, channel switching, channel fading, or clocking issues if the communication system is not correctly configured. These tests will need to be well documented to ensure the system is tested for different operating and tripping situations that could lead to failures in protection schemes.

The test should determine if the scheme operates correctly or if the scheme has subtle and/or noncritical problems. All problems found during testing should be addressed to determine changes that can be made to eliminate these issues. Trending data over time will help to determine if degradation of the system has occurred, which also can help to determine component failure within the system. If segmented testing is necessary, it is critical to ensure zones of testing overlap to verify that the entire system is correctly tested.

In addition to planned testing, utilizing inservice operational data can provide valuable information that can be used to document system performance. Documenting faults and system events can be used to validate performance of part or the entire communication system. Event, oscillographic, and Supervisory Control and Data Acquisition (SCADA) records can be used to verify recently exercised elements of the protection scheme, including communication elements.

14.10 Documenting Microprocessor Relay Settings

The information provided in this section has now moved to FIST 6-4 Management of Protective Relay settings.

Operation, Maintenance, and Field
Test Procedures for Protective
Relays and Associated Circuits

Appendix A

GLOSSARY OF TERMS PROTECTIVE RELAYING AND PROTECTION CIRCUITS

Definitions of Relay Terms

The following definitions include terminology and nomenclature in common use. They have been compiled using information from the Institute of Electrical and Electronics Engineers and the National Association of Relay Manufacturers. In instances where different terms are used synonymously, one has been defined, and others have been cross-referenced. When the phrase “sometimes used for” is employed, a preference is implied for the terminology following the phrase; when “same as” is used, no strong preference is inferred.

Acceptance test: A calibration and functional test of a new or replacement relay to ensure it is in proper working order prior to installation.

Air gap: Sometimes used for contact separation or for magnetic air gap.

Ampere-turns: The product of the number of turns in a magnetic coil and the root means square (rms) current in amperes passing through the coil.

Armature: Hinged or pivoted moving part of the magnetic circuit of an electromagnetic relay. It is used in a general sense to mean any moving part that actuates contacts in response to a change in coil current.

Armature contact: Sometimes used for a movable contact.

Armature relay: A relay operated by an electromagnet that, when energized, causes an armature to be attracted to a fixed pole (or poles).

Auxiliary relay: A relay that operates in response to opening and closing of its operating circuit to assist another relay or device in performing a function.

Back contacts: Sometimes used for the stationary contact of single-pole, normally closed contacts. Same as normally closed contacts.

Backstop: The part of a relay that limits movement of the armature away from the pole piece or core.

Backup relaying: Supplementary relaying designed to operate if a primary relay should malfunction or a circuit breaker fails to operate. Backup relaying usually disconnects more of the power system than just the part with the faulty element, since this is necessary to remove the abnormal condition and to minimize the effect on the remainder of the system.

Bar relay: A relay so designed that a bar actuates several contacts simultaneously.

Break-before-make contacts: Contacts that interrupt one circuit before establishing another.

Break contact: Same as back contact.

Break delay: Sometimes used for release time.

Bridging: Describes a contact transfer in which the movable contact touches the normally open contact before leaving the normally closed contact during the transfer action, thus never completely opening the circuit of the movable contact.

Brush: Sometimes used for wiper.

Burden: The impedance of the circuit connected to the secondary winding. For potential transformers the burden is often expressed in terms of equivalent volt-amperes (VA) and power factor at a given voltage and frequency.

Calibration: See relay calibration.

Chatter: A sustained rapid opening and closing of contacts caused by variations in the coil current, mechanical vibration, shock, problems with laminations in the magnetic core, or incorrect travel of the armature.

Clapper relay: Sometimes used for armature relay.

Close-differential relay: Sometimes used for marginal relay.

Coil: A magnetic or thermal winding to which energy is supplied to activate the relay.

Commissioning test: A test of the total relay system after installation or modification or for troubleshooting purposes. It includes tests of the instrument transformers and all wiring and relay outputs with actual trip testing of the circuit breaker.

Contact arrangement: The combination of different basic contact forms to make up the entire relay switching structure.

Contact bounce: Uncontrolled making and breaking of contact when relay contacts are moved to the closed position.

Contact follow: The distance two contacts travel together after just touching.

Contact gap: Same as contact separation.

Contact nomenclature: Each movable contact of a relay is a pole. A combination of one stationary contact and one movable contact, which are engaged when the coil is de-energized, is referred to as back, break, form B, or normally closed contacts and is abbreviated NC. A combination of stationary contact and movable contact, which is engaged when the coil is energized, is referred to as front, make, form A, or normally open contacts and is abbreviated NO. These are called single-pole, single-throw contacts and are abbreviated NC SPST or NO SPST.

A combination of two stationary contacts and one movable contact, which engages one of them when the coil is energized and the other when the coil is de-energized, is called transfer, form C, or single-pole double-throw contacts and is abbreviated SPDT.

ST NO and ST NC contacts are called single-throw normally open or normally closed contacts. The N stands for “normally,” and this always refers to what position the contact is in when the coil is de-energized. Therefore, NO means the contacts are separated when the coil is de-energized, while NC means the contacts are closed when the coil is de-energized.

A combination in which a movable contact simultaneously makes and simultaneously breaks connection between two stationary contacts is called double-break contacts and is abbreviated DB. For normally open contacts, this combination may be called double-make contacts.

Relay contact notations are given in the following order:

1. Poles
2. Throws
3. Normal position
4. Double break, if double-break or double-make contacts

Examples: SPST NO DB designates single-pole, single-throw, normally open, double-break contacts.

All contacts are single-break except when noted as DB. Relays having several sets of differently functioning contacts will have the contact forms listed in alphabetical order of their letter symbols.

Example: 1A2B refers to SPST NO contacts and DPST NC contacts.

For a relay on which the moving contact engages more than two stationary contacts during its cycle of operation, the contact arrangement is described as MPNT, where M is the number of poles and N is the number of throws (e.g., 8P 20T).

In addition to the above relay contact information, it is common to see 52A and 52B contacts used in protection circuits. The 52A contact is an auxiliary contact in the breaker, and the “A” indicates that the contact follows the main contact position of the breaker. For a 52B contact, the “B” indicates the contacts are opposite of the main contact position of the breaker.

Contact over travel: Sometimes used for contact follow.

Contact separation: Maximum distance between mating relay contacts when the contacts are in the open position.

Contact spring: A current-carrying spring to which contacts are fastened.

Contacts: Current-carrying parts of a relay that engage or disengage to make or break electrical circuits.

Contactactor: Sometimes used for a relay with heavy-duty contacts.

Continuity-transfer contacts: Same as make-before-break contacts.

Continuous-duty relay: A relay that may be energized with rated coil voltage or current at rated contact load for a period of 3 hours or more without failure and without exceeding specified temperature requirements.

Current balance relay: A relay that allows tripping whenever there is an abnormal change in the division of current between two circuits.

Current rating: See rated coil current and rated contact current.

Current relay: A relay designed to operate at a particular rated coil current rather than at a given rated coil voltage.

Current transformer: A transformer used to reduce a primary current to a secondary value for use with protective relaying, control device, and metering circuits, typically 5 amps.

Cycle timer: A controlling mechanism that opens or closes contacts according to a preset cycle.

De-energize: To de-energize a relay is to disconnect the relay coil from its power source.

Definite-purpose relay: A relay with a feature distinguishing it from a general-purpose relay. Types of definite purpose relays are interlock, selector, stepping, sequence, latch-in, and time-delay.

Delay relay: A relay that is intentionally designed for a time delay between the energizing or de-energizing instant and the time that the relay contacts open or close.

Diagnostic tests (troubleshooting): Tests to find and correct relay settings, design or wiring errors, or malfunctions. These tests usually are conducted after a protective system problem is identified or suspected, such as failure to trip.

Differential relay: A relay having multiple elements that function when voltage, current, or power difference between elements reach a predetermined value.

Directional relay: A relay that trips when current flow is in one direction only.

Directional test: A test of directional relay elements to verify that the relay will operate or block properly when the relay input quantities are in the proper direction. A directional test is sometimes performed with the equipment carrying normal load. It always is performed as part of a relay system commissioning and as part of routine maintenance testing or troubleshooting tests.

Double-break contacts: See contact nomenclature.

Double-make contacts: See contact nomenclature.

Double-throw contacts: See contact nomenclature.

Double-wound coil: A winding consisting of two parts wound on the same core.

Drop-out values: Drop-out current, voltage, or power is the maximum value for which contacts of a previously energized relay will always assume their de-energized positions.

Duty cycle: Rated working time of a device compared to its idle time.

Electric reset: A term applied to a relay indicating that, following an operation, its contacts must be reset electrically to their original positions.

Electromagnetic relay: A relay whose operation involves using a magnetic field, produced by an electromagnet.

Electrostatic spring shields: Metallic shields between two relay springs to minimize capacitance between them.

Enclosed relay: A relay with both coil and contacts protected from the surrounding medium by a cover not normally airtight.

Energize: To energize a relay is to apply rated voltage to its coil.

Extension spring: Same as restoring spring.

Fast-operate relay: A high-speed relay specifically designed for short-operate time but not short-release time.

Fast-operate, fast-release relay: A high-speed relay specifically designed for both short-operate time and short-release time.

Fast-operate, slow-release relay: A relay specifically designed for short-release time but not short-operate time.

Fast-release relay: A high-speed relay specifically designed for short-release time but not short-operate time.

Fixed contacts: Stationary contacts of a relay that are engaged and disengaged by moving contacts to make or break circuits.

Flight time: Sometimes used for transfer time.

Follow-through contacts: Contacts with contact follow.

Frame: The structure on which the coil and contact assembly are mounted.

Front contacts: Sometimes used for the stationary contact of single-pole; normally open contacts. (See contact nomenclature.)

Functional test (relay): A calibration, if required, and functional test of a relay to verify the relay functions according to its settings and specifications. Typical tests include characteristics tests, timing tests, pickup tests, and instantaneous trip (fault trip) tests. These tests typically are performed as part of the acceptance test, part of routine maintenance, or part of troubleshooting testing.

Gasket-sealed relay: An airtight relay, sealed with a gasket that is not bonded to the other sealing material.

General-purpose relay: A relay with ratings, design, construction, and operational characteristics, which make it adaptable to a wide variety of uses.

Hand-reset: A qualifying term applied to a relay indicating that, following an operation, the contacts must be reset manually.

Harsh conditions: Defined as excessive vibration, dusty atmospheres, and extreme temperature changes.

Header: The part of a hermetically sealed relay through which electrical terminals pass.

Hermetically sealed relay: An airtight relay, the sealing of which involves fusing or soldering but does not use a gasket.

High-speed relay: A relay specifically designed for short-operate time, short-release time, or both.

Hold values: The hold current, voltage, or power is the minimum value for which contacts of a previously energized relay always will maintain their energized positions.

Homing: A qualifying term applied to a stepping relay indicating that wipers, upon completion of an operational cycle, are stepped around or back to the start position.

Hum: As applied to relays, the sound caused by mechanical vibration resulting from alternating current flowing in the coil.

Impregnated coils: Coils that have been permeated with phenolic or similar varnish to protect them from mechanical vibration, handling, fungus, and moisture.

Inductive winding: As contrasted with a noninductive winding, an inductive winding is a coil having a specifically designed inductance.

Input: A physical quantity or quantities to which the relay is designed to respond. For microprocessor-based relays, the input consists of an analog to digital convertor that must be tested to ensure the input values match the predetermined input values.

Instrument relay: A relay, the operation of which depends upon principles employed in electrical measuring instruments, such as the electro-dynamometer, iron-vane, and D'Arsonval.

Instrument transformer: Instrument transformers comprise current transformers, potential transformers, and coupling capacitor voltage transformers (CCVTs), which reduce current and voltage to levels useable by protective relays, control devices, and metering circuits.

Interlock relay: A relay composed of two or more coils with their armatures and associated contacts so arranged that freedom of one armature to move or its coil to be energized is dependent upon the position of the armature.

Intermittent-duty relay: A relay that must be de-energized at occasional or periodic intervals to avoid excessive temperature.

Latch-in relay: A relay having contacts that lock in either the energized or de-energized position until reset, either manually or electrically.

Level: As applied to a stepping relay, level is used to denote one bank or series of contacts.

Level contact: Sometimes used for movable contact.

Load test: This test involves measuring the alternating currents and/or voltages applied to the relay when the equipment is under normal load. The relative phase angles of the currents and/or voltages also are measured during the load test. This test may be performed while troubleshooting a suspected problem to ensure the relay is receiving the proper quantities.

Locking relay: Sometimes used for latch-in relay.

Lock-Out Relay: A device that trips and maintains associated equipment or devices as inoperative until it is reset by an operator, either locally or remotely.

Low-capacitance contacts: A type of contact construction providing low intercontact capacitance.

Make contact: Same as front contact.

Magnetic air gap: A nonmagnetic portion of a magnetic circuit.

Magnetic freezing: The sticking of a relay armature to the core, after de-energization, due to residual magnetism of the core.

Magnetic switch: Sometimes used for relay.

Make-before-break contacts: Double-throw contacts so arranged that moving contacts establish a new circuit before disrupting the old one.

Make delay: Sometimes used for operate time.

Mercury-contact relay: A relay in which the contacting medium is mercury.

Microprocessor relay: Relay in which the input current or voltage waveform is sampled three or more times per power cycle and conversion of samples to numeric values for measurement calculation by microprocessor electronics that also are performing self-diagnostics.

Motor-driven relay: A relay actuated by the rotation of the shaft of some type of motor (i.e., a shaded-pole, induction-disk, or hysteresis motor).

Movable contact: A contact that moves, when the relay is energized or de-energized, to engage or disengage one or more stationary contacts.

Multiple-break contacts: Contacts so arranged that, when they open, the circuit is interrupted in two or more places.

Multiple pileup: An arrangement of contact springs composed of two or more separate pileups.

Multiple stack: Same as multiple pileup.

Neutral relay: In contrast to a polarized relay, a relay where the movement of the armature is independent of direction of flow of current through the relay coil.

Nonbridging: Describes a contact transfer where the movable contact leaves one contact before touching the next.

Nonhoming: A qualifying term applied to a stepping relay indicating that wipers, upon completion of an operational cycle, do not return to the home position but are at rest on the last used set of contacts.

Noninductive windings: A type of winding where the magnetic fields produced by two parts of the winding cancel each other and provide a noninductive resistance.

Nonmagnetic shim: A nonmagnetic material attached to the armature or core of a relay to prevent iron-to-iron contact in an energized relay.

Nonoperate value: The nonoperate voltage, current, or power is the maximum value for which contacts of a previously de-energized relay will always maintain their de-energized positions.

Normal position: De-energized position, open or closed, of contacts due to spring tension or gravity.

Normal sequence of operation: The sequence in which all normally closed contacts open before closure of normally open contacts of the assembly.

Normal-speed relay: A relay in which no attempt has been made either to increase or decrease the operate time or the release time.

Normally open contacts: A combination of a stationary contact and a movable contact that are not engaged when the coil is de-energized.

Off-limit contacts: Contacts on a stepping relay used to indicate when the wiper has reached the limiting position on its arc and must be returned to normal before the circuit can function again.

Off-normal contacts: Stationary contacts on a homing stepping relay used to indicate when the wiper is not in the starting position.

Operate time: If a relay has only normally closed contacts, its operate time is the longest time interval given by definition (a) below. If a relay has normally open contacts (regardless of whether or not it has normally closed contacts), its operate time is the longest time interval given by definition (b).

(a) Operate time for normally closed contacts: Total elapsed time from the instant the coil is energized until contacts have opened (i.e., contact current is zero).

(b) Operate time for normally open contacts: Total elapsed time from the instant the coil is energized until contacts are closed and all contact bounce has ceased.

Operate values: Same as pickup values.

Operating frequency: The rated alternating current frequency of the supply voltage at which the relay coil is designed to operate.

Output: The relay output consists of the terminals connected to internal tripping contacts that open or close based upon the input signal to the relay.

Overload relay: A relay specifically designed to operate when its coil current reaches a predetermined value above normal.

Partially enclosed relay: A relay with either contacts or coil (but not both) protected from the surrounding medium by a cover that is not airtight.

Partially sealed relay: A relay with either contacts or coil (but not both) sealed.

Periodic testing: Time-based routine maintenance testing and calibration of the relays and overall protection system on a schedule.

Pickup values: Pickup voltage, current, or power is the minimum value for which contacts of a previously de-energized relay will always assume their energized position.

Pileup: A set of contact arms, assemblies, or springs placed one on top of the other with insulation between them.

Plant protection system testing: A total end-to-end test of the relay system. It includes primary injection (if possible) of test currents or voltages in the primaries of the instrument transformers and an actual trip of the circuit breaker. This proves all of the elements of the protection system, including wiring and tripping, functions.

Plunger relay: A relay operated by energizing an electromagnetic coil that, in turn, operates a movable core or plunger by solenoid action.

Polarized relay: A relay that depends on the polarity of the energizing current to operate.

Pole: See contact nomenclature.

Pole face: The part of the magnetic structure on the end of the core nearest the armature.

Potential Transformer: A transformer used to reduce a primary voltage to a secondary value for use with protective relaying, control device, and metering circuits, typically 69 or 120 volts.

Protective relay system: The entire protective system, including the relays themselves, all associated wiring and terminals, all relay inputs and their current and voltage sources, control relays, and associated sensors and transducers. This includes all relay outputs and all devices in breaker trip circuits such as lockout relays, limit switches, etc. This includes breaker trip coils and circuit breakers. This also includes both alternating current and direct current supply systems, including the battery, battery chargers, and all associated wiring and circuits.

Pull-in values: Same as pickup values.

Pull-on values: Sometimes used for pickup values.

Qualified Person: A qualified person must be properly trained, knowledgeable, and experienced in relay and protection system maintenance and safety, as well as testing techniques for specific protection equipment located at their facility.

Ratchet relay: A stepping relay actuated by an armature-driven ratchet.

Rated coil current: Steady-state coil current at which the relay is designed to operate.

Rated coil voltage: Coil voltage at which the relay is designed to operate.

Rated contact current: Current that the contacts are designed to carry for their rated life.

Relay: A device that is operated by variation in conditions of one electric circuit to affect operation of other devices in the same or other electric circuits by either opening circuits or closing circuits or both.

Relay calibration: To adjust relay operation to ensure that the relay operates within factory specifications. Electromechanical relays may require the adjustment of spring tension, time dial, magnets, contacts, etc. Solid-state relays may require the adjustment of potentiometers, variable capacitors, or variable inductors to ensure correct operation.

Release factor: Ratio, expressed in percent, of dropout current to rated current or the analogous voltage ratio.

Release time: If a relay has only normally open contacts, its release time is the longest time interval given by definition (a) below. If a relay has normally closed

contacts (regardless of whether or not it has normally open contacts), its operate time is the longest time interval given by definition (b).

(a) **Release time for normally open contacts:** Total elapsed time from the instant the coil current starts to drop from its rated value until contacts have opened (i.e., contact current is zero).

(b) **Release time for normally closed contacts:** Total time from the instant the coil current starts to drop from its rated value until contacts are closed and all contact bounce has ceased.

Release values: Same as dropout values.

Repeating timer: A timing device that, upon completion of one operating cycle, continues to repeat automatically until excitation is removed.

Residual gap: Length of magnetic air gap between the pole-face center and nearest point on the armature, when the armature is in the energized position.

Residual pins or screws: Nonmagnetic pins or screws attached to either the armature or core of a relay to prevent the armature from directly contacting the magnetic core.

Residual setting: Value of the residual gap obtained by using an adjustable residual screw.

Residual shim: Same as nonmagnetic shim.

Restoring spring: A spring that moves the armature to, and holds it in, the normal position when the relay is de-energized.

Retractile spring: Sometimes used for restoring spring.

Rotary relay: Sometimes used for motor-driven relay.

Rotary stepping relay: Same as stepping relay.

Rotary stepping switch: Same as stepping relay.

Sealed relay: A relay that has both coil and contacts enclosed in an airtight cover.

Self-cleaning contacts: Sometimes used for wiping contacts.

Selector relay: A relay capable of automatically selecting one or more circuits from a number of circuits.

Sequence control: Automatic control of a series of operations in a predetermined order.

Sequence relay: A relay that controls two or more sets of contacts in a definite predetermined sequence.

Shading coil: Sometimes used for shading ring.

Shading ring: A shorted turn surrounding a portion of the core of an alternating current magnet, causing a delay in change of magnetic flux in that part, thereby preventing contact chatter.

Slave relay: Sometimes used for auxiliary relay.

Slow-operate, fast-release relay: A relay specifically designed for long-operate time and short-release time.

Slow-operate relay: A slow-speed relay designed for long-operate time but not for long-release time.

Slow-operate, slow-release relay: A slow-speed relay specifically designed for both long-operate time and long-release time.

Slow-release relay: A slow-speed relay specifically designed for long-release time but not for long-operate time.

Slow-speed relay: A relay designed for long-operate time, long-release time, or both.

Slug: A highly conductive sleeve placed over the core to aid in retarding the establishing or decay of flux within the magnetic path.

Solenoid relay: Sometimes used for a plunger relay.

Solid-state relays: Relays that use various low-power diodes, transistors, and thyristors and associated resistor and capacitors. These components are designed into logic units used in many ways.

Special protection system: Designed to detect abnormal system conditions and take automatic, preplanned action (other than the isolation of faulted elements) to provide acceptable system performance. Special protection system actions may result in reduction in load or generation or changes in system configuration to maintain system stability, acceptable voltages, or acceptable facility loading.

Special-purpose relay: A relay with an application requiring special features that are not characteristic of conventional general-purpose or definite-purpose relays.

Specified duty relay: A relay designed to function with a specified duty cycle but might not be suitable for other duty cycles.

Spring buffer: A bearing member made of insulating material that transmits motion of the armature to the movable contact and from one movable contact to another in the same pileup.

Spring pileup: Same as pileup.

Spring stud: Same as spring buffer.

Stack: Same as pileup.

Stationary contact: A contact member that is rigidly fastened to the relay frame and is not moved as a direct result of energizing or de-energizing the relay.

Stepping relay: A relay whose contacts are stepped to successive positions as the coil is energized in pulses. Some stepping relays may be stepped in either direction. (The stepping relay is also called a rotary stepping switch or a rotary stepping relay.)

Target: A supplementary device operated either mechanically or electrically, to indicate visibly that the relay has operated or completed its function.

Telephone-type relay: Sometimes used for an armature relay with an end-mounted coil and spring pileup contacts mounted parallel to the long axis of the relay coil.

Tension spring: Sometimes used for restoring spring.

Thermal relay: A relay operated by the heating effect of electric current flow.

Throw: See contact nomenclature.

Time-delay relay: A relay in which a delayed action purposely is introduced.

Timing relay: A motor-driven time-delay relay.

Transfer time: Total elapsed time between breaking one set of contacts and the making of another set of contacts.

(a) **Transfer time on operate:** Total elapsed time from the instant the normally closed contacts start to open until the normally open contacts are closed and all contact bounce has ceased.

(b) **Transfer time on release:** Total elapsed time from the instant the normally open contacts start to open until the normally closed contacts are closed and all contact bounce has ceased.

Transit time: Same as transfer time.

Trip values: Trip voltage, current, or power is a rated value where a bistable polarized relay will transfer from one contact to another.

Undercurrent relay: A relay specifically designed to function when its coil current falls below a predetermined value.

Undervoltage relay: A relay specifically designed to function when its coil voltage falls below a predetermined value.

Unenclosed relay: A relay that does not have its contacts or coil protected from the surrounding medium by a cover.

Winding: Same as coil.

Wiper: A moving contact on a stepping relay.

Wiping contacts: Contacts designed to have some relative motion during the interval from the instant of touching until completion of closing motion.

Appendix B

ELECTRICAL DEVICE NUMBERS DEFINITIONS AND FUNCTIONS

Devices in control and switching equipment are referred to by numbers, with appropriate suffix letters when necessary, according to the functions they perform.

These numbers are based on the Institute of Electrical and Electronics Engineers (IEEE™) standard for automatic switchgear and are incorporated in Institute of Electrical and Electronics Engineers C37.2™ 2008.

Device No.	Definition and Function
01.	Master Element is the initiating device, such as a control switch, voltage relay, or float switch, which serves either directly or through such permissive devices as protective and time-delay relays to place equipment in or out of operation.
02.	Time-Delay Starting or Closing Relay is a device that functions to give a desired amount of time delay before or after any point of operation in a switching sequence or protective relay system, except as specifically provided by device functions 48, 62, and 79.
03.	Checking or Interlocking Relay is a relay that operates in response to the position of a number of other devices (or to a number of predetermined conditions) in equipment, to allow an operating sequence to proceed, to stop, or to provide a check of the position of these devices or of these conditions for any purpose.
04.	Master Contactor is a device, generally controlled by device function 1 or equivalent and the required permissive and protective devices, that serves to make and break necessary control circuits to place equipment into operation under desired conditions and to take it out of operation under other or abnormal conditions.
05.	Stopping Device is a control device used primarily to shut down equipment and hold it out of operation. (This device may be manually or electrically actuated but excludes the function of electrical lockout [see device function 86] on abnormal conditions.)
06.	Starting Circuit Breaker is a device whose principal function is to connect a machine to its source of starting voltage.
07.	Rate-of-change Relay is a device that operates when the rate-of-change of the measured quantity exceeds a threshold value, except as defined by device 63.
08.	Control Power Disconnecting Device is a disconnecting device, such as knife switch, circuit breaker, or pull-out fuse block, used, respectively, to connect and disconnect the source of control power to and from the control bus or equipment. NOTE: Control power is considered to include auxiliary power, which supplies such apparatus as small motors and heaters.
09.	Reversing Device is a device that is used to reverse a machine field or to perform any other reversing function.

10. **Unit Sequence Switch** is a switch that is used to change the sequence in which units may be placed in and out of service in multiple-unit equipment.
11. **Multifunction Device** is a device that performs three or more comparatively important functions that could only be designated by combining several device function numbers. All of the functions performed by device 11 shall be defined in the drawing legend, device function definition list, or relay-setting record.
- NOTE:** If only two relatively important functions are performed by the device, it is preferred that both function numbers be used.
12. **Over-Speed Device** is usually a direct-connected speed switch that functions on machine over-speed.
13. **Synchronous-Speed Device** is a device, such as a centrifugal-speed switch, a slip-frequency relay, a voltage relay, an undercurrent relay, or any type of device, that operates at approximately synchronous speed of a machine.
14. **Under-Speed Device** is a device that functions when the speed of a machine falls below a predetermined value.
15. **Speed or Frequency Matching Device** is a device that functions to match and hold speed or frequency of a machine or of a system equal to, or approximately equal to, that of another machine, source, or system.
16. **Data Communications Device** is a device that supports the serial and/or network communications that are a part of the substation control and protection system. This clause establishes the assignment of IEEE™ Std. C37.2™ device number 16 for a data communications device handling protective relaying or other substation communication traffic. The following suffix list identifies specific functions of a component identified as device 16. The first suffix letter shall be either S (serial devices for RS-232, 422, or 485 communications) or E (for Ethernet components). The second and subsequent suffix letters shall be one or more of the following letters to further define the device:
- C** Security processing function (Virtual Private Network [VPN], encryption, etc.)
 - F** Firewall or message filter function
 - M** Network managed function (e.g., configured via Simple Network Management Protocol [SNMP])
 - R** Router
 - S** Switch (Examples: Port switch on a dial up connection is 16SS, and an Ethernet switch is 16ES)
 - T** Telephone component (Example: auto-answer modem)
17. **Shunting or Discharge Switch** is a switch that serves to open or close a shunting circuit around any piece of apparatus (except a resistor), such as a machine field, a machine armature, a capacitor, or a reactor.
- NOTE:** This excludes devices that perform such shunting operations as may be necessary in the process of starting a machine by devices 6 or 42, or their equivalent, and also excludes device function 73 that serves for the switching of resistors.
18. **Accelerating or Decelerating Device** is a device that is used to close or to cause closing of circuits, used to increase or decrease the speed of a machine.

19. **Starting-to-Running Transition Contactor** is a device that operates to initiate or cause the automatic transfer of a machine from starting to running power connection.
20. **Electrically Operated Valve** is an electrically operated, controlled, or monitored valve used in a fluid line.
21. **Distance Relay** is a relay that functions when circuit admittance, impedance, or reactance increases or decreases beyond predetermined limits.
22. **Equalizer Circuit Breaker** is a breaker that serves to control or to make and break equalizer or current-balancing connections for a machine field, or for regulating equipment, in a multiple-unit installation.
23. **Temperature Control Device** is a device that functions to raise or lower temperature of a machine or other apparatus, or of any medium, when its temperature falls below or rises above a predetermined value.

NOTE: An example is a thermostat that switches on a space heater in a switchgear assembly when temperature falls to a desired value as distinguished from a device that is used to provide automatic temperature regulation between close limits and would be designated as device function 90T.
24. **Volts per Hertz Relay** is a device that the ratio of voltage to frequency is above a preset value or is below a different preset value. The relay may have any combination of instantaneous or time-delayed characteristics.
25. **Synchronizing or Synchronism-Check Device** is a device that operates when two alternating current (ac) circuits are within the desired limits of frequency, phase angle, or voltage to permit or to cause the paralleling of these two circuits.
26. **Apparatus Thermal Device** is a device that functions when temperature of the shunt field or amortisseur winding of a machine, or that of a load limiting or load shifting resistor or of a liquid or other medium, exceeds a predetermined value; or if temperature of the protected apparatus, such as a power rectifier or of any medium, decreases below a predetermined value.
27. **Undervoltage Relay** is a relay that functions on a given value of undervoltage.
28. **Flame Detector** is a device that monitors the presence of a pilot or main flame in such apparatus as a gas turbine or a steam boiler.
29. **Isolating Contactor or Switch** is a device that is used expressly for disconnecting one circuit from another for purposes of emergency operation, maintenance, or test.
30. **Annunciator Relay** is a nonautomatically reset device that gives a number of separate visual indications upon functioning of protective devices and also may be arranged to perform a lockout function.
31. **Separate Excitation Device** is a device that connects a circuit, such as shunt field of a synchronous converter, to a source of separate excitation during starting sequence, or one that energizes the excitation and ignition circuits of a power rectifier.
32. **Directional Power Relay** is a device that functions on a desired value of power flow in a given direction or upon reverse power resulting from arc-back in the anode or cathode circuits of a power rectifier.

33. **Position Switch** is a switch that makes or breaks contact when the main device or piece of apparatus, which has no device function number, reaches a given position.
34. **Master Sequence Device** is a device, such as a motor-operated multicontact switch or equivalent, or a programming device, such as a computer, that establishes or determines the operating sequence of major devices in equipment during starting and stopping or during other sequential switching operations.
35. **Brush-Operating or Slip-Ring Short-Circuiting Device** is a device for raising, lowering, or shifting brushes of a machine, for short circuiting its slip rings, or for engaging or disengaging contacts of a mechanical rectifier.
36. **Polarity or Polarizing Voltage Device** is a device that operates, or permits operation of, another device on a predetermined polarity only or verifies presence of a polarizing voltage in equipment.
37. **Undercurrent or Underpower Relay** is a relay that functions when current or power flow decreases below a predetermined value.
38. **Bearing Protective Device** is a device that functions on excessive bearing temperature or on other abnormal mechanical conditions associated with the bearing, such as undue wear, which may eventually result in excessive bearing temperature or failure.
39. **Mechanical Condition Monitor** is a device that functions when an abnormal mechanical condition occurs (except that associated with bearings as covered under device function 38), such as excessive vibration, eccentricity, expansion, shock, tilting, or seal failure.
40. **Field Relay** is a relay that functions on a given or abnormally low value or failure of machine field current or on excessive value of the reactive component of armature current in an ac machine indicating abnormally low field excitation.
41. **Field Circuit Breaker** is a device that functions to apply or remove field excitation of a machine.
42. **Running Circuit Breaker** is a device whose principal function is to connect a machine to its source of running or operating voltage. This function also may be used for a device, such as a contactor, that is used in series with a circuit breaker or other fault protecting means, primarily for frequent opening and closing of the circuit.
43. **Manual Transfer or Selector Device** is a manually operated device that transfers control circuits to modify the plan of operation of switching equipment or of some of the devices.
44. **Unit Sequence Starting Relay** is a relay that functions to start the next available unit in a multiple-unit lineup upon failure or nonavailability of the normally preceding unit.
45. **Atmospheric Condition Monitor** is a device that functions upon occurrence of an abnormal atmospheric condition, such as damaging fumes, explosive mixtures, smoke, or fire.
46. **Reverse-Phase or Phase-Balance Current Relay** is a relay that functions when the polyphase currents are of reverse-phase sequence or when polyphase currents are unbalanced or contain negative phase-sequence components above a given amount.

47. **Phase-Sequence or Phase-balanced Voltage Relay** is a relay that functions upon a predetermined value of polyphase voltage in the desired phase sequence.
48. **Incomplete Sequence Relay** is a relay that generally returns equipment to normal or off position and locks it out if normal starting, operating, or stopping sequence is not properly completed within a predetermined time. If the device is used for alarm purposes only, it preferably should be designated as 48A (alarm).
49. **Machine or Transformer Thermal Relay** is a relay that functions when temperature of a machine armature or other load-carrying winding or element of a machine or temperature of a power rectifier or power transformer (including a power rectifier transformer) exceeds a predetermined value.
50. **Instantaneous Overcurrent Relay** is a relay that functions instantaneously on an excessive value of current or on an excessive rate of current rise—thus, indicating a fault in apparatus or circuit being protected.
51. **AC Inverse Time Overcurrent Relay** is a relay with either a definite or inverse time characteristic that functions when current in an ac circuit exceeds a predetermined value.
52. **AC Circuit Breaker** is a device that is used to close and interrupt an ac power circuit under normal conditions or to interrupt this circuit under fault or emergency conditions.
53. **Field Excitation Relay** is a relay that forces the direct current (dc) machine field excitation to build up during the starting or that functions when the machine voltage has built up to a given value.
54. **Turning Gear Engaging Device** is a device either electrically operated, controlled, or monitored that functions to cause the turning gear to engage (or disengage) the machine shaft.
55. **Power Factor Relay** is a relay that operates when the power factor in an ac circuit rises above or falls below a predetermined value.
56. **Field Application Relay** is a relay that automatically controls application of field excitation to an ac motor at some predetermined point in the slip cycle.
57. **Short-Circuiting or Grounding Device** is a primary circuit switching device that functions to short circuit or to ground a circuit in response to automatic or manual means.
58. **Rectification Failure Relay** is a device that functions if one or more anodes of a power rectifier fail to fire, or to detect an arc-back, or on failure of a diode to conduct or block properly.
59. **Overvoltage Relay** is a relay that operates when its input voltage exceeds a predetermined value.
60. **Voltage or Current Balance Relay** is a relay that operates on a given difference in voltage, or current input or output, of two circuits.
61. **Density Switch or Sensor** is a device that operates at a given density value or at a given rate of change of density.
62. **Time-Delay Stopping or Opening Relay** is a device that imposes a time delay in conjunction with the device that initiates the shutdown, stopping, or opening operation in an automatic sequence.

63. **Pressure Switch** is a switch that operates on given pressure values or on a given rate of change of pressure.
64. **Ground Protective Relay** is a relay that functions on failure of insulation of a machine, transformer, or of other apparatus to ground or on flashover of a dc machine to ground.
- NOTE:** This function is assigned only to a relay that detects flow of current from the frame of a machine or enclosing case or the structure of a piece of apparatus to ground, or it detects a ground on a normally ungrounded winding or circuit. It is not applied to a device connected in the secondary circuit of a current transformer or in the secondary neutral of current transformers connected in the power circuit of a normally grounded system.
65. **Governor** is the assembly of fluid, electrical, or mechanical control equipment used for regulating flow of water, steam, or other medium to the prime mover for such purposes as starting, holding speed or load, or stopping.
66. **Notching or Jogging Device** is a device that functions to allow only a specified number of operations of a given device, piece of equipment, or a specified number of successive operations within a given time of each other. It is also a device that functions to energize a circuit periodically, for fractions of specified time intervals, or that is used to permit intermittent acceleration or jogging of a machine at low speeds for positioning.
67. **AC Directional Overcurrent Relay** is a relay that functions on a desired value of ac overcurrent flowing in a predetermined direction.
68. **Blocking or "Out-of-Step" Relay** initiates a pilot signal for blocking of tripping on external faults in a transmission line or in other apparatus under predetermined conditions, or it cooperates with other devices to block tripping or to block reclosing on an out-of-step condition or on power swings.
69. **Permissive Control Device** is generally a two-position, manually operated switch that, in one position, permits closing of a circuit breaker or placing equipment into operation and, in the other position, prevents the circuit breaker or equipment from being operated.
70. **Rheostat** is a variable resistance device used in an electric circuit, which is electrically operated or has other electrical accessories, such as auxiliary, position, or limit switches.
71. **Liquid Level Switch** is a switch that operates on a given level value or on a given rate of change of level of a liquid.
72. **DC Circuit Breaker** is a circuit breaker that is used to close and interrupt a dc power circuit under normal conditions or to interrupt a circuit under fault or emergency conditions.
73. **Load-Resistor Contactor** is a contactor that is used to shunt or insert a step of loading, limiting, shifting, or indicating resistance in a power circuit or to switch a space heater in circuit or to switch a light or regenerative load resistor of a power rectifier or other machine in and out of a circuit.
74. **Alarm Relay** is a relay other than an annunciator, as covered under device function 30, that is used to operate, or to operate in connection with, a visual or audible alarm.

75. **Position Changing Mechanism** is a mechanism used to move a main device from one position to another in equipment—i.e., shifting a removable circuit breaker to and from the connected, disconnected, and test positions.
76. **DC Overcurrent Relay** is a relay that functions when current in a dc circuit exceeds a given value.
77. **Telemetry Device** is a transmitting device used to generate and transmit, to a remote location, an electrical signal representing a measured quantity; or a receiver used to receive the electrical signal from a remote transmitter and convert the signal to represent the original measured quantity.
78. **Phase-Angle Measuring Relay** is a relay that functions at a predetermined phase angle between two voltages, between two currents, or between a voltage and a current.
NOTE: This device number definition recently has been updated and in the past included “out-of-step” relays. The new IEEE™ Std. C37.2™-2008 indicates the “out-of-step” relay as being a device number 68.
79. **AC Reclosing Relay** is a relay that controls automatic reclosing and locking out of an ac circuit breaker.
80. **Flow Switch** is a switch that operates on a given flow or on a given rate of change of flow.
81. **Frequency Relay** is a relay that functions on a predetermined value of frequency (either under or over or on normal system frequency) or rate of change of frequency.
82. **DC Load-Measuring Reclosing Relay** is a relay that controls automatic closing and reclosing of a dc circuit interrupter, generally in response to load circuit conditions.
83. **Automatic Selective Control or Transfer Relay** is a relay that operates to select automatically between certain sources or conditions in equipment or that performs a transfer operation automatically.
84. **Operating Mechanism** is the complete electrical mechanism or servo-mechanism, including operating motor, solenoids, position switches, etc., for a tap changer, induction regulator, or any similar piece of apparatus that otherwise has no device function number.
85. **Pilot Communications, Carrier, or Pilot-Wire Relay** is a device that is operated, restrained, or has its function modified by communications transmitted or received via any media used for relaying.
86. **Lock-Out Relay** is a device that trips and maintains associated equipment or devices as inoperative until it is reset by an operator, either locally or remotely.
87. **Differential Protective Relay** is a device that operates on a percentage, phase angle or other quantitative difference of two or more currents or other electrical quantities.
88. **Auxiliary Motor or Motor Generator** is a device used to operate auxiliary equipment, such as pumps, blowers, exciters, rotating magnetic amplifiers, etc.

89. **Line Switch** is a device used as a disconnect, load-interrupter, circuit switcher, or isolating switch in an ac or dc power circuit. (This device function number normally is not necessary unless the switch is electrically operated or has electrical accessories, such as an auxiliary switch, a magnetic lock, etc.)
90. **Regulating Device** is a device that regulates a quantity, or quantities, such as voltage, current, power, speed, frequency, temperature, and load, at a certain value or between certain (generally close) limits for machines, tie lines, or other apparatus.
91. **Voltage Directional Relay** is a relay that operates when voltage across an open circuit breaker or contactor exceeds a given value in a given direction.
92. **Voltage and Power Directional Relay** is a relay that permits or causes connection of two circuits when the voltage difference between them exceeds a given value in a predetermined direction and causes these two circuits to be disconnected from each other when the power flowing between them exceeds a given value in the opposite direction.
93. **Field-Changing Contactor** is a contactor that functions to increase or decrease, in one step, the value of field excitation on a machine.
94. **Tripping or Trip-Free Relay** is a relay that functions to trip a circuit breaker, contactor, or equipment; to permit immediate tripping by other device; or to prevent immediate reclosing of a circuit interrupter if it should open automatically even though its closing circuit is activated or energized.
95. **Used only for specific applications.** These numbers are used in individual specific installations if none of the functions assigned to the numbers from 1 through 94 are suitable.
- 96.
- 97.
- 98.

Appendix C

CURRENT TRANSFORMER ACCURACY CLASSES

American National Standards Institute/Institute of Electrical and Electronics Engineers Standard Current Transformer Accuracy Classes

The typical nomenclature for classifying current transformers (CTs) using the American National Standards Institute (ANSI)/Institute of Electrical and Electronics Engineers (IEEE™) method is as follows:

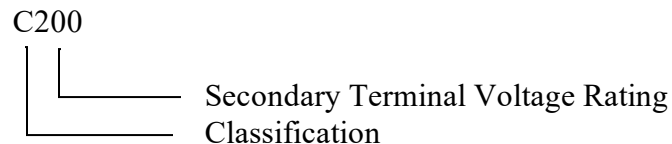

Standard values for relaying CTs are:

Classification: C, K, T, H, or L
Secondary Terminal Voltage Rating: 10, 20, 50, 100, 200, 400, or 800 volts
(at 20 times rated current)

The classification rating of the transformer describes the characteristics of the CT. For example, a C rating (for Calculation) would indicate that leakage flux is negligible; and the excitation characteristic can be used directly to calculate ratio errors. A good rule of thumb to minimize CT saturation is to select a CT with a C rating of at least twice that required for maximum steady-state symmetrical fault current. The K rating is the same as the C rating, but the knee voltage must be at least 70 percent (%) of the secondary terminal voltage. This provides an extended linear region before the CT approaches saturation. A T rating (for Test) indicates that the ratio error must be determined by testing the CT. The T classification has a significant core leakage flux contributing to the ratio error. The H and L ratings are the old ANSI classifications and are only applicable to very old CTs manufactured before 1954. The L ratings were rated at a specified burden and at 20 times normal current. The H ratings were at any combination of burden from 5 to 20 times normal current.

The secondary terminal voltage rating is the voltage the CT will deliver to a standard burden at 20 times the rated secondary current (100 amperes [amps] for a 5-amp-rated CT) without exceeding a 10% ratio correction. See appendix D, table D-1. The ratio correction shall maintain within 10% for any secondary current from 1 to 20 times the secondary current.

The above CT is a C200. This indicates that the CT has a C classification rating, and the error can be calculated from the manufacturer's data. The 200 indicates that, for a typical 5-amp CT at 20 times the overcurrent, the CT will develop 200 volts for a burden of 2 ohms.

$$200 \text{ V} = 2 \Omega * 5 \text{ A} * 20$$

International Electrotechnical Commission (IEC) Standard CT Accuracy Classes

The typical nomenclature for classifying CTs using the IEC method is as follows:

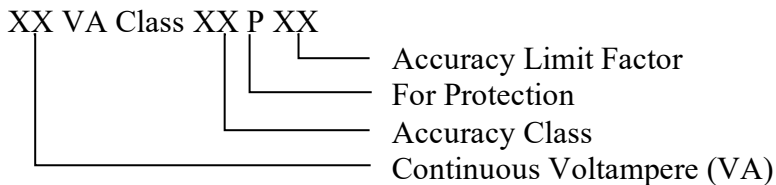

Standard values for relaying CTs are

Continuous VA:	2.5, 5, 10, 15, and 30
Accuracy Classes:	5 and 10%
Accuracy-limit Factor:	5, 10, 15, 20, and 30
Rated Secondary Amperes:	1, 2, 5 (5 amps preferred)

The following CT, 30 VA Class 10 P 30 rated at 5 amps, could output $30 \text{ VA} / 5 \text{ amps} = 6 \text{ volts}$. It would have no greater than 10% error up to $30 \times 6 = 180 \text{ volts}$ secondary. The maximum permissible burden would be $30 \text{ VA} / (5 \text{ amps})^2 = 1.2 \text{ ohms}$. This would be equivalent to an ANSI/IEEE™ C180 CT.

CT Construction – Bushing, Window, or Bar-Type CTs with Uniformly Distributed Windings

Current transformers of this type have no “primary winding” as such. The primary is the conductor on which the current is to be measured; it passes once through the center of a toroid core. A toroid is a donut of magnetic material used as a low reluctance path to concentrate magnetic flux (see figure C-1). Since the secondary winding is wrapped and uniformly distributed around the core and only a single primary turn is used, essentially all flux that links the primary conductor also links the secondary winding, as shown in figure C-1.

Note: Even though the primary conductor passes straight through the toroid and is not actually wrapped around the core, it still is called a “turn.”

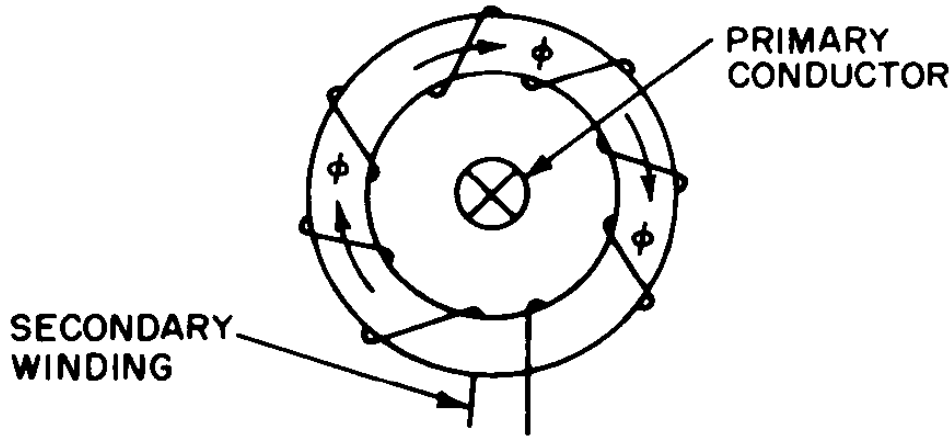

Figure C-1. Uniformly distributed secondary winding.

Because there is essentially no leakage flux, there is negligible leakage reactance. Therefore, excitation characteristics can be used directly to determine performance. Current transformers of this type have a “C” accuracy classification per the ANSI/IEEE™ Std. C57.13-1993, indicating that the CT ratio can be calculated if the burden, secondary winding resistance, and the excitation characteristics are known. ANSI/IEEE™ Std. C57.13-1993 states that “if transformers have a “C” classification on the full winding, all tapped sections shall be so arranged that the ratio can be calculated from excitation characteristics.”

CT Construction - Wound Primary Current Transformers (Without Uniformly Distributed Windings)

Wound-type current transformers are usually constructed with more than one primary turn and unevenly distributed windings. Because of the physical space required for insulation, bracing of the primary winding, and fringing effects of nonuniformly distributed windings, leakage flux is present, which does not link both primary and secondary windings. Figure C-2 is intended to illustrate the leakage flux but is not intended to correctly represent how CTs are constructed.

The presence of leakage flux has a significant effect on CT performance. When this flux is appreciable, it is not possible to calculate the CT ratio knowing the burden and the excitation characteristics. CTs of this type have a “T” accuracy classification according to ANSI/IEEE™ Std. C57.13-1993, indicating that primary to secondary CT ratios must be determined by test.

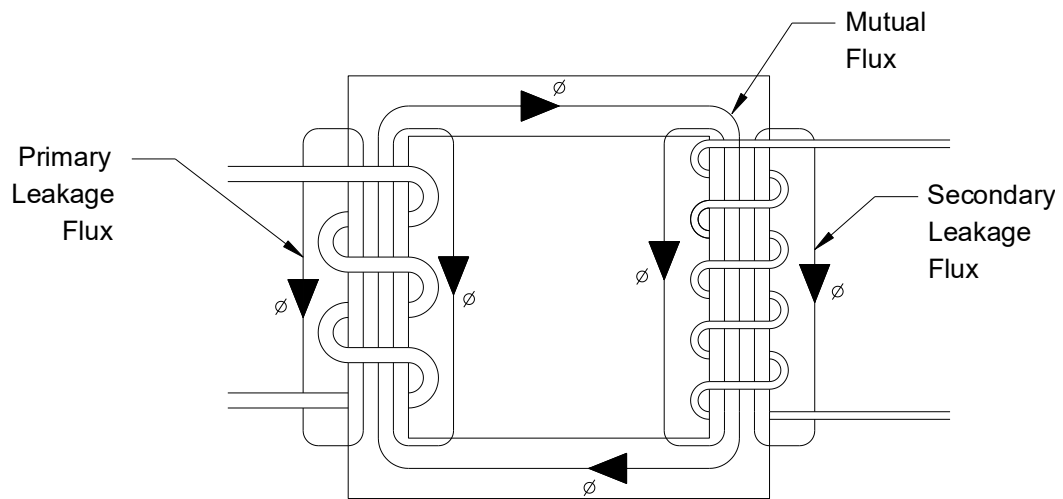

Figure C-2. Leakage flux.

Appendix D

INSTRUMENT TRANSFORMER BURDEN MEASUREMENTS FOR CURRENT TRANSFORMERS AND POTENTIAL TRANSFORMERS

Instrument transformer burden is a critical factor that can impact the accuracy of measurements during normal operations and during a fault. Thus, burden measurements are performed on a periodic basis to ensure that burden is within transformer specifications.

External Burden Measurements

Current and potential transformers are used to reduce a primary current or voltage to a secondary value that is easier to work with. The load on the secondary side of the current transformer (CT) or potential transformer (PT) is called the burden. The burden for CTs and PTs is defined as:

$$\begin{array}{ll} \text{For CTs} & \text{For PTs} \\ Z_B = \frac{VA}{I^2} \Omega & Z_B = \frac{V^2}{VA} \Omega \end{array}$$

Where voltampere (VA) is the voltampere burden and I or V is the amperes (amps) or volts (V) at which the burden was measured or specified.

In most cases, measuring the voltage and current magnitude on the system and then using ohms law will yield an estimate of the burden.

$$Z_B = \frac{V_{MEASURED}}{I_{MEASURED}}$$

This method is easy to perform with standard tools but produces a slightly higher value for burden than the more accurate method of measuring phase angle as described below.

If more accurate values are warranted or if the measured burden is greater than the nameplate burden, then a phase angle meter is needed. Using a phase angle meter will yield the angle between the voltage and current in the system. In this case, the voltage is used as reference, angle of 0 degrees (0°), and a current angle (θ°) will be measured. Using this convention, the equation for the burden will yield:

$$Z_B = \frac{V_{MEASURED} \angle 0^\circ}{I_{MEASURED} \angle \theta^\circ}$$

This equation will yield an answer in one of the following forms:

$$\begin{aligned} \text{Rectangular Coordinates: } Z_B &= r + xi \Omega \\ \text{Polar Coordinates: } Z_B &= r \angle \delta^\circ \Omega \end{aligned}$$

An alternative method for measuring the phase angle is to use an oscilloscope with two isolated inputs. Using a properly rated probe to measure the voltage and a current probe to measure the current, it is then possible to determine the phase shift between the two signals. Table D-1 compares the time between the two 60-hertz (Hz) signals and converts them into degrees phase shift. Some of the newer digital scopes will calculate the phase angle between the two signals automatically.

Table D-1. Conversion between time and phase shift at 60 Hz

Time (milliseconds)	Phase Shift (degrees)	Time (milliseconds)	Phase Shift (degrees)	Time (milliseconds)	Phase Shift (degrees)	Time (milliseconds)	Phase Shift (degrees)
0.231	5	4.398	95	8.565	185	12.731	275
0.463	10	4.630	100	8.796	190	12.963	280
0.694	15	4.861	105	9.028	195	13.194	285
0.926	20	5.093	110	9.259	200	13.426	290
1.157	25	5.324	115	9.491	205	13.657	295
1.389	30	5.556	120	9.722	210	13.889	300
1.620	35	5.787	125	9.954	215	14.120	305
1.852	40	6.019	130	10.185	220	14.352	310
2.083	45	6.250	135	10.417	225	14.583	315
2.315	50	6.481	140	10.648	230	14.815	320
2.546	55	6.713	145	10.880	235	15.046	325
2.778	60	6.944	150	11.111	240	15.278	330
3.009	65	7.176	155	11.343	245	15.509	335
3.241	70	7.407	160	11.574	250	15.741	340
3.472	75	7.639	165	11.806	255	15.972	345
3.704	80	7.870	170	12.037	260	16.204	350
3.935	85	8.102	175	12.269	265	16.435	355
4.167	90	8.333	180	12.500	270	16.667	360

$$\text{Degrees Phase Shift} = 21.6 * \text{time (milliseconds)}$$

Burden Test Methods

These tests can be performed either online or offline. For the online tests, PTs should be energized near rated voltage; and CTs should be loaded to near the equipment or CT rating. If this loading cannot be reached, then the CT should be loaded to at least 20 percent (%) of rated secondary current (1 amp for a 5-amp-rated CT) to allow for accurate measurements. Secondary current and voltage values can be measured as close as practical to the transformer with a digital multimeter (DMM) and clamp-on current meter rated for the values being measured.

For offline tests, current is injected into the secondary circuit as close as practical to the CT; and voltage is injected into the PT circuit by lifting the leads near the PT. The CT can remain in the circuit during these tests because it will appear as an open circuit, but the PT cannot be energized. Thus, its secondary leads need to

be isolated from the secondary circuit and voltage injection leads. To determine the external connected burden in voltamperes for a CT, measure the voltage required to drive rated current (typically 5 amps) through the connected load. To determine the external connected burden in voltamperes for a PT, measure the current required to drive rated voltage (typically 120 or 69 volts) through the connected load. Secondary current and voltage values can be measured with a DMM and clamp-on current meter rated for the values being measured. If the reactive portion of the burden is also desired, a phase-angle meter must be used. Take care during the offline test to disable the trip output of relays that may pick up. Relay operation may cause unintended consequences within the plant.

Current Transformer Detailed Burden Explanation

The total load applied to a CT is called the “burden.” The total burden (typically used for calculation) is the combination of internal CT burden and the external burden connected to the CT terminals.

CT Internal Resistance

The internal CT burden is the resistance of the secondary winding. Measuring the internal resistance of the CT secondary winding can be accomplished with a digital ohmmeter.

Caution: Following internal CT burden measurements, it is recommended to demagnetize the CT (see appendix E). Direct current used to measure the CT internal resistance can magnetize the CT, which will affect its accuracy.

CT External Burden

The external burden consists of the impedance of the CT secondary load plus the secondary circuit lead resistance. If the external burden measurement is performed at a location other than the terminals of the CT, then the lead resistance between the CT and the external burden measurement point must be measured or calculated (figure D-1). CT manufacturers typically state on the CT nameplates the standard burden rating (standard burden ratings are described below). The measured external burden should be less than the standard burden rating. If the external burden is higher than the nameplate burden rating, then the following should be explored:

- The CT may have a higher actual external burden rating than indicated by the standard burden rating. Data sheets or measurements may demonstrate a higher burden rating for the CT.

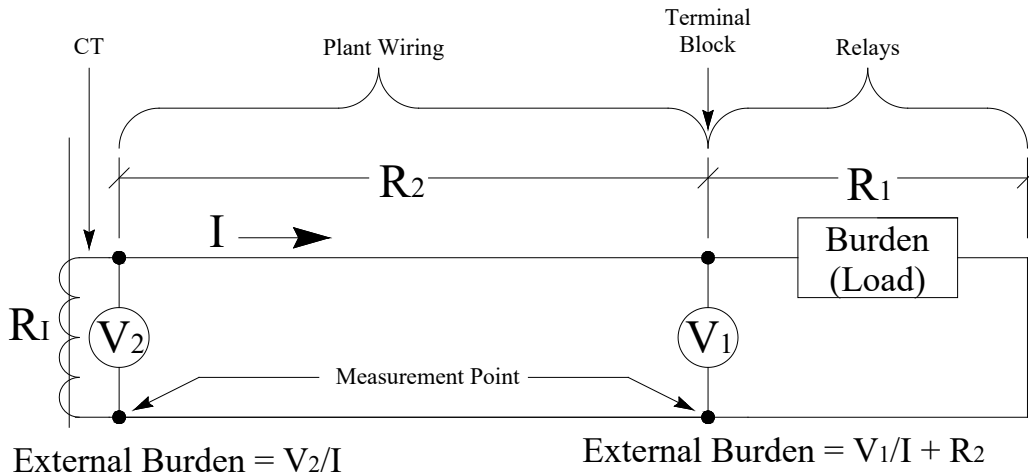

Note: External burden does not include CT internal burden, R_I

Figure D-1. CT burden measurement details.

- A protection system study may be needed to demonstrate that the CT and, thus, relays will perform as intended at the higher burden level.
- The impedance of the secondary leads or relays could be decreased. This may require newer relays that typically have lower input impedance or increasing the wire American wire gauge (AWG) of the secondary leads.
- Replace the existing CT with one rated for the external burden

When measuring CT burden, the following should be considered:

1. To best represent inservice burden, the relays and other external devices must be on the correct tap.
2. Phase-to-neutral measurements of relay circuits can be high, especially if electromechanical ground relays with sensitive settings are involved.
3. Phase-to-neutral and phase-to-phase measurements of bus differential circuits can yield high results due to impedance of the electromechanical differential relay operating coil or external reactor. As discussed in section 5.1, the external reactor may need to be shorted during burden measurements.

Burden measurements can be compared to calculated values to confirm circuit wiring and satisfactory contact resistances of terminal blocks and test devices. These comparisons also will give indications to the performance of the system.

Standard Burdens

Tables D-2 and D-3 offer a good baseline for standard burdens, but not all CTs and PTs are listed in the table. It may be necessary to refer to manufacturer reference sheets or to perform testing on the specific unit experimentally to determine the CT/PT characteristics. One example would be a CT that has a burden designation of C200. While the CT is considered a C200, datasheet or experimental testing may prove the CT is actually a “C250.” Because a “C250” is not a standard burden designation, the CT is labeled as C200. In this case, the CT is capable of supplying a greater burden than indicated in the table.

Table D-2. Standard burdens for current transformers with 5A secondary windings¹

Burdens (B-X.X)	Burden Designation ² (Ω)		Resistance (Ω)	Inductance (mH)	Impedance (Ω)	Volt-amperes	Power Factor	Secondary Terminal Voltage ³	
Metering Burdens	B-0.1		0.09	0.116	0.1	2.5	0.9	10	
	B-0.2		0.18	0.232	0.2	5.0	0.9	20	
	B-0.5		0.45	0.580	0.5	12.5	0.9	50	
	B-0.9		0.81	1.040	0.9	22.5	0.9	90	
	B-1.8		1.62	2.080	1.8	45.0	0.9	180	
Relaying Burdens	B-1	or	C100	0.50	2.300	1.0	25.0	0.5	100
	B-2	or	C200	1.00	4.600	2.0	50.0	0.5	200
	B-4	or	C400	2.00	9.200	4.0	100.0	0.5	400
	B-8	or	C800	4.00	18.400	8.0	200.0	0.5	800

¹ If a current transformer secondary winding is rated at other than 5A, ohmic burdens for specification and rating shall be derived by multiplying the resistance and inductance of the table by $(5/[\text{ampere rating}])^2$, the VA at rated current, the power factor, and the burden designation remaining the same.

² These standard burdens have no significance at frequencies other than 60 hertz.

³ The secondary terminal voltage is measured at 20 times nominal current without exceeding 10% ratio correction.

Table D-3. Standard burdens for voltage transformers

Characteristics on standard burdens ¹			Characteristics on 120-V Basis			Characteristics on 69.3 V Basis		
Designation	VA	Power factor	Resistance (Ω)	Inductance (mH)	Impedance (Ω)	Resistance (Ω)	Inductance (Ω)	Impedance (Ω)
W	12.5	0.1	115.2	3.0400	1152	38.4	1.0100	384
X	25.0	0.7	403.2	1.0900	576	134.4	0.3640	192
M	35.0	0.2	82.3	1.0700	411	27.4	0.3560	137
Y	75.0	0.85	163.2	0.2680	192	54.4	0.0894	64
Z	200.0	0.85	61.2	1.0100	72	20.4	0.0335	24
ZZ	400.0	0.85	30.6	0.0503	36	10.2	0.0168	12

¹ These standard burdens have no significance at frequencies other than 60 hertz.

Delta Connected Current Transformer Online Burden Measurements

There are several incidences when CTs are connected in a delta configuration. This occurs on many older differential relays circuits located on Y-delta connected power transformers. Often measuring the external load on a CT in this configuration is difficult because the CT leads before the delta connections are not accessible. Figure D-2 below demonstrates this issue.

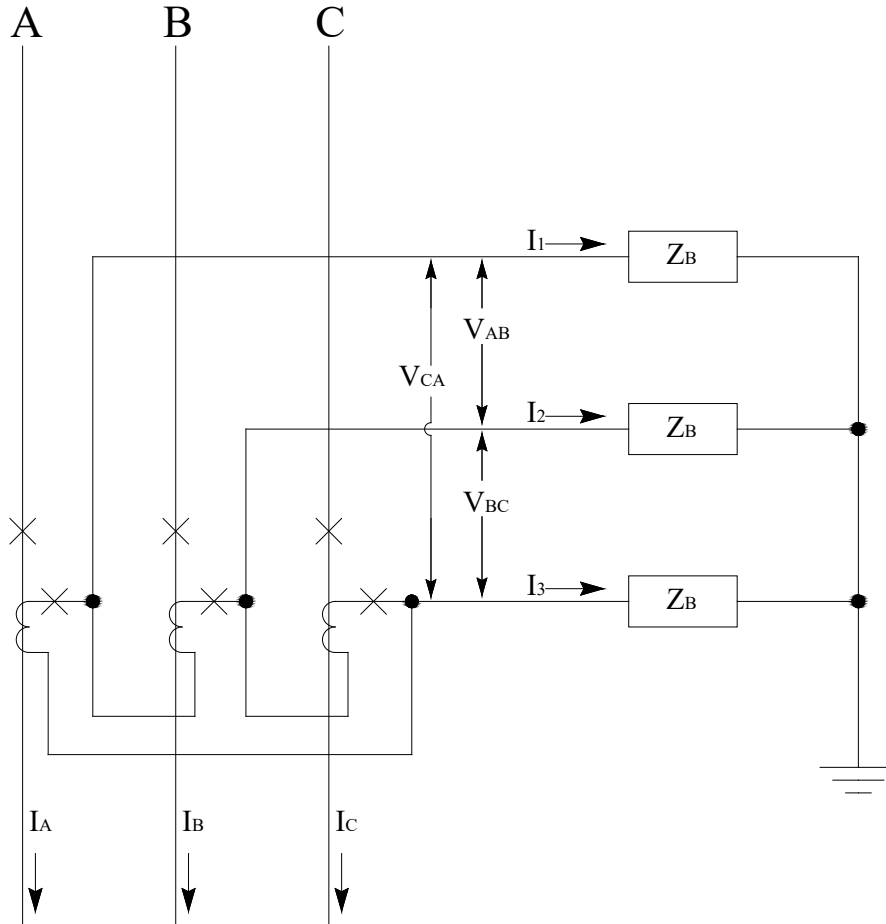

Figure D-2. Delta connected CTs.

In this case, the delta currents (I_1 , I_2 , and I_3) and the line-to-line voltages (V_{ab} , V_{bc} , and V_{ca}) can be measured. If we assume that the magnitude of the three currents and voltages are approximately equal, then the CT burden can be estimated using the following equation.

$$Z_{CT} = \frac{\sqrt{3} \times V_{LL}}{I} \quad \text{where } I \approx I_1 \approx I_2 \approx I_3 \quad \text{and } V_{LL} \approx V_{ab} \approx V_{bc} \approx V_{ca}$$

Appendix E

FIELD TESTING OF RELAYING CURRENT TRANSFORMER

There are a number of tests that can be performed on current transformers (CT) to ensure proper operation. Refer to American National Standards Institute (ANSI)/Institute of Electrical and Electronics Engineers (IEEE™) Standard (Std.) C57.13.1-1981 for additional information on CT testing. There are several automated test instruments available to assist in field testing of transformers. They typically automate one or more test methods as described below. If an automated test set is not available, these tests can be performed with standard test tools.

Consideration of Remanence (Demagnetizing CTs)

Performance of both C and T class current transformers is influenced by remanence or residual magnetism. When testing CTs, it is important to understand remanence flux that may be present within the CT. The available core materials used in all CTs are subject to hysteresis. The phenomenon is shown by plotting curves of magnetic flux density as a function of magnetizing force (figure E-1). When the current is interrupted, the flux density does not become zero when the current does.

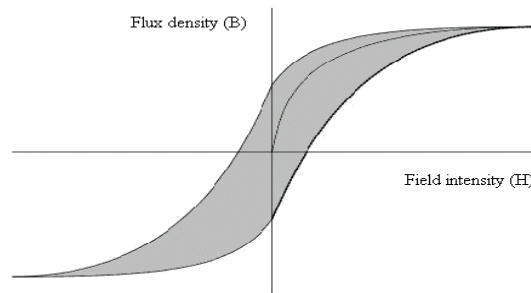

Figure E-1. Curves plotted showing magnetic flux density as a function of magnetizing force.

When the current contains a direct current (dc) component, the magnetizing force in one direction is much greater than in the other. The curves resulting are both displaced from the origin and distorted in shape, with a large extension to the right or left in the direction of the dc component. The CT becomes saturated and the resultant waveforms are shown in figure E-2.

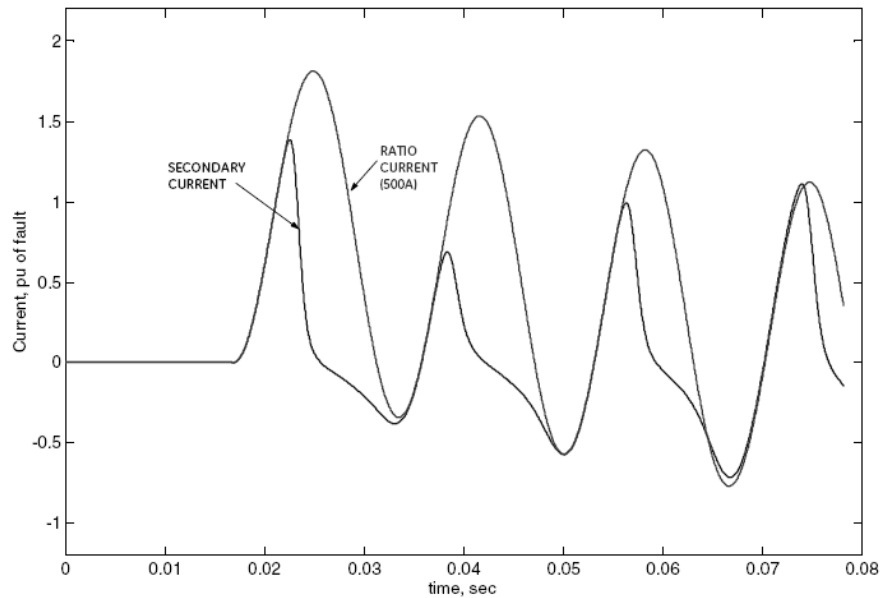

Figure E-2. Example of a 50:5 CT under fault current of 500 amperes (amps) (fully offset).

If the interrupted current is high, or if it contains a large dc component and is interrupted when total flux is high, remanence will be substantial, perhaps being above the flux equivalent of the knee point shown on the excitation curve (figure E-3).

When the CT is next energized, the flux changes required will start from the remanence value; and if the required change is in the direction to add to the remanence flux, a large part of the cycle may find the CT saturated. When this occurs, much of the primary current is required for excitation; and secondary output is significantly reduced and distorted on alternate half cycles, similar to the secondary current waveform in figure E-2.

The maximum remanence flux is obtained when the primary current is interrupted while the transformer is in a saturated state. In addition, testing that requires dc to flow in the transformer winding will also result in remanence. Once the remanence flux is established, it is dissipated very little under service conditions.

The remanence flux will remain until the core is demagnetized. Demagnetizing the CT can be accomplished by applying a variable alternating current (ac) voltage to the CT secondary. The initial magnitude of the ac voltage should be at a level that will force the CT into saturation. The voltage then is slowly and continuously decreased to zero. Test connections are identical to those required for the excitation test (figure E-4). Additional methods of demagnetizing CTs are outlined in IEEE™ Std. C57.13-1993, Requirements for Instrument Transformers,.

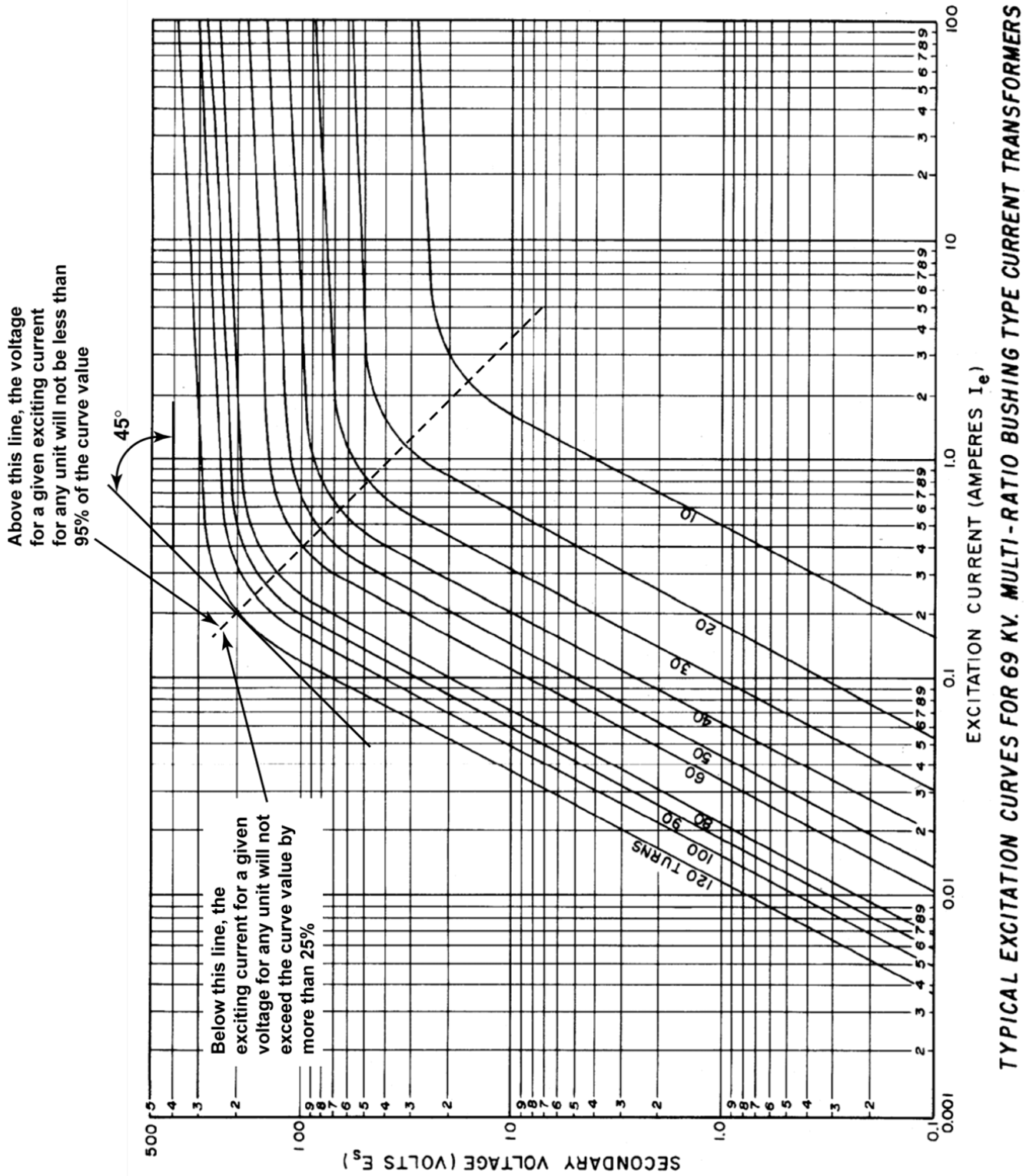

Figure E-3. Typical excitation curve – C200 CT.

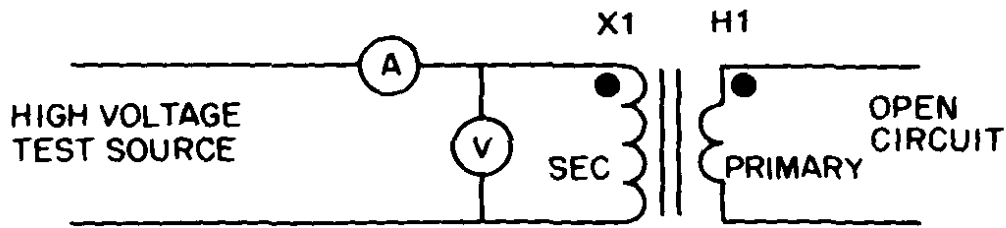

Figure E-4. CT excitation, voltage method to measure ratio, and demagnetizing test setup.

If there is any reason to suspect that a CT has been recently subjected to heavy currents, possibly involving a large dc component, or been magnetized by any application of direct current, it should be demagnetized before being used for any purpose requiring accurate current measurement.

CAUTION: Internal CT burdens measurements can magnetize the CT. It is recommended to demagnetize the CT following this test.

Ratio Tests for CTs

There are several accepted methods for testing ratios of CTs.

Voltage Method

An automated potential transformer (PT)/CT test set can be used for this measurement, and its test connections are shown in figure E-5. The test method also can be performed manually. A suitable voltage, below saturation, is applied to the full secondary winding; and the primary voltage is then measured using a high-impedance voltmeter. The test setup is similar to figure E-4.

Saturation occurs with voltages above the knee of the saturation curve (see the curves at the end of this section). The turns ratio should be about the same as the voltage ratio. While performing this test, it is also possible to determine the tap selection ratios by measuring the tap selection voltage and comparing this to the voltage across the full winding.

NOTE: The ANSI CT class voltage rating never should be exceeded during this test.

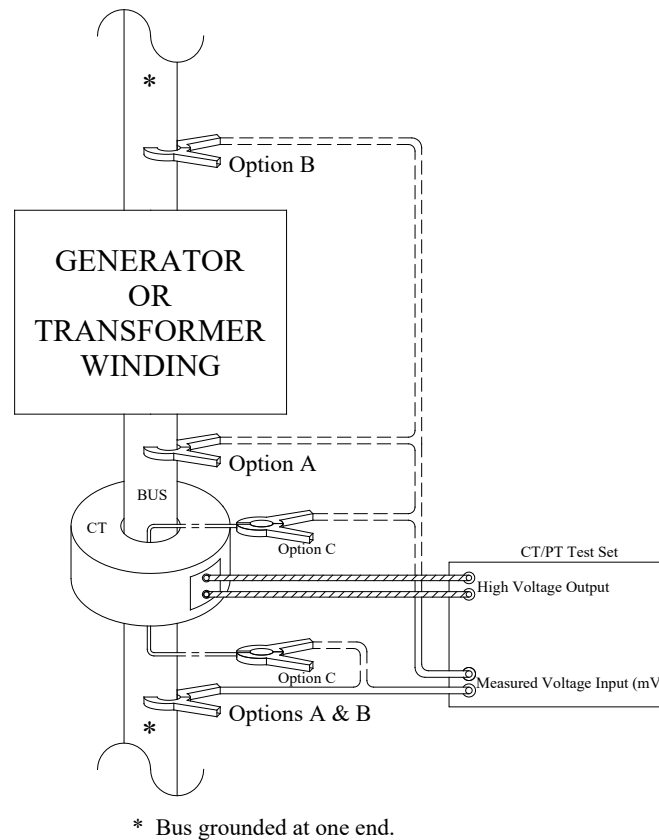

Figure E-5. Offline voltage method.

Current Method

An automated PT/CT test set can be used for this measurement, and its test connections are shown in figure E-6. Any CTs in series with the CT under test should be shorted and isolated, if there is a chance of damage to other meters or relays or accidental tripping.

The test method also can be performed manually. This method requires a high current source, an additional reference current transformer of known turns ratio, and two ammeters (figure E-7). The source of current for this test could be a loading transformer with a ratio that is approximately 120/240–6/12 volt (V) with an output capable of driving the rated CT primary current for about 30 minutes.

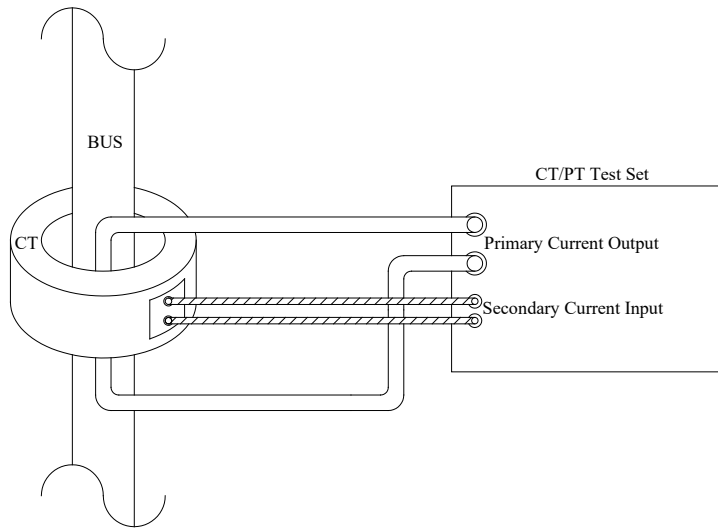

Figure E-6. Offline current method for testing CTs with test set.

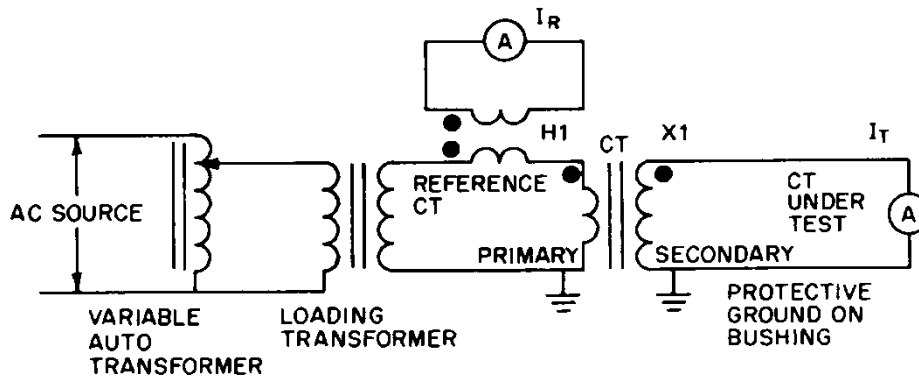

Figure E-7. Offline current method for manually testing CTs.

The loading transformer should be driven using a variable autotransformer to control the output current. The test is performed by controlling the loading current through both the CT under test and the reference CT over a range of values and comparing the output of the two secondary currents.

$$N_t = N_r \frac{I_r}{I_t}$$

Where: N_r is the number of turns of the reference CT

I_r is the measured current of the reference CT

I_t is the measured current of the test CT

NOTE: The accuracy of the reference transformer should be at least three times greater than the desired accuracy.

The test should be performed with the CT secondary shorted to measure the CT turns ratio and phase angle. It can be repeated at its actual burden to confirm its accuracy and phase angle under load.

Online Method

This method is performed with the plant equipment online and current flowing through the CT. To perform this test, it is necessary to have a second CT (a reference CT) of a known ratio located on the same bus. Typically, this is a plant CT whose turn ratio has been verified by one of the methods listed above. Two high-precision digital voltmeters and clamp-on current probes are used to compare the output current of the reference CT and the output current of the CT under test. A scope or phase angle meter can be used to measure the phase angle, if desired. By shifting the load on this bus, the CT can be measured at various current levels.

Polarity Check

There are generally three accepted testing methods to perform a polarity check on a CT.

DC Voltage Test

The dc test is performed by momentarily connecting a 6- to 12-volt alkaline type battery across the secondary of the CT (figure E-8). A millivoltmeter or milliammeter is connected across the primary side of the CT. While connecting to both the primary and secondary sides of the CT, careful attention to polarity should be observed. If the positive terminal of the battery is connected to the secondary terminal, X_1 , and the meter positive terminal is connected to the primary terminal, H_1 , the meter should read a pulse in the positive direction when the dc voltage is applied and in the negative direction when the dc voltage is removed.

It is advisable to demagnetize CTs following this test due to the rather large dc current. Demagnetizing the CT can be accomplished per the “Consideration of Remanence” section.

CAUTION: A dangerous voltage may be generated while disconnecting the battery from the CT winding. The proper personal protective equipment should be used.

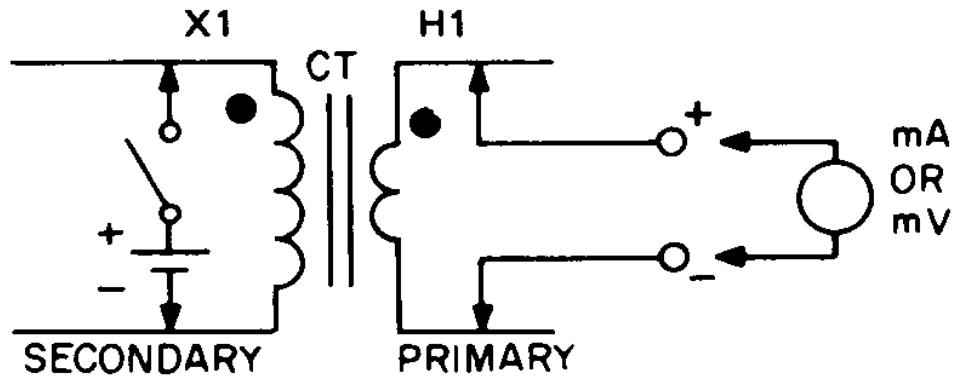

Figure E-8. DC voltage polarity test for CTs.

AC Voltage Test

Utilizing a dual channel oscilloscope, connect the primary to channel 1 and the secondary to channel 2. Apply an ac voltage to the secondary winding and then compare this value to the voltage induced on the primary winding. If the resulting waveforms are in agreement, the polarity is correct. If the scope is in calibration, then it may be possible to determine the turns ratio while performing the polarity check by measuring the magnitude of the voltage waveforms and multiplying by the scale factor of the oscilloscope.

Current Method

If the current method was used for the ratio test, then the same method can easily be used to determine the polarity of the CT. The reference CT secondary should be paralleled with the test CT secondary. An oscilloscope may be used to easily determine the polarity by comparing the secondary reference CT current to the CT under test.

Online Method

To determine the polarity of a CT using the online method, use the online method for measuring CT ratio and use an oscilloscope to determine if signals are in phase.

Excitation Test

Excitation tests can be performed on both C and T class CTs, allowing for comparison with published or previously measured data. As with all field testing, it is highly recommended to trend current field data with previous results. Any major deviations should be noted and reviewed. Before performing the excitation test, the CT should be demagnetized.

To perform an excitation test, connect a high voltage ac test source to the secondary of the CT. The primary circuit should be open for the test. The input voltage to the secondary is then varied, and the current drawn by the winding at

each selected value of voltage is recorded (figure E-4). Readings located near the knee of the curve are the most important. Readings should be taken up to two times rated secondary current, two times rated secondary voltage, or to the point where voltage applied is 1,500 volts. Do not exceed 1,500 volts applied.

The secondary root mean square (rms) exciting current should be plotted on the abscissa, x-axis; while the secondary rms exciting voltage is plotted on the ordinate, y-axis. See the curves on figure E-3 for bushing type CTs. The point at which a 45-degree line⁴ is drawn tangent to the curve is called the “knee” of the excitation curve; see figure E-3. Any deviations from the manufacturer’s data or past test results should be investigated. The excitation current should not exceed the curve tolerance as stated by the manufacturer or, if not stated, 125% of the original curve value. Deviations from the curve may be an indication of turn-to-turn shorts internal to the CT, distortion of the supply voltage, or the presence of a completed conduction path around the CT core.

The selection of equipment for this test is very important. The ammeter should be able to read true rms current; a digital multimeter should be capable of taking these values. A digital rms multimeter should be sufficient for taking voltage measurements.

The test also can be performed by energizing the primary winding of the CT and measuring the secondary winding open-circuit voltage. The current must then be divided by the CT turns ratio to compare this data to standard curves provided by the manufacturer.

CAUTION: If voltage is applied to a portion of the secondary winding, the voltage across the full winding will be proportionately higher because of the autotransformer action. Current transformers should not remain energized at voltages above the knee of the excitation curve any longer than is necessary to take measurements. **DO NOT EXCEED 1,500 VOLTS!**

Auxiliary CTs also can be tested and they tend to saturate at much less secondary current and burden than large multiratio bushing type CTs. Excitation curves should be available for all CTs, especially for auxiliary CTs used in protective relaying circuits (see figure E-3).

⁴ IEEE™ Std. C57.13-1993 – 45-degree method is most common within Reclamation and is based on the material used and overall construction of the CT. A 30-degree method typically is used for CTs with an air gap such as split core CTs. Refer to the manufacturer’s information to determine which method should be used during testing.

Operation, Maintenance, and Field
Test Procedures for Protective
Relays and Associated Circuits

Appendix F

FIELD TESTING OF RELAYING POTENTIAL TRANSFORMER

There are several automated test instruments available to assist in field testing of transformers. They typically automate one or more test methods as described below. If an automated test set is not available, these tests can be performed with standard test tools.

Burden Measurements

For secondary circuit burden measurements, see appendix D.

Turns Ratio Test for Potential Transformers

A turns ratio test is performed by energizing the potential transformer (PT) and measuring the primary to secondary ratio with no burden (i.e., open circuited secondary).

CAUTION: Many of the tests called for in this section involve high voltage. Therefore, they should be performed only by qualified personnel familiar with hazards that exist in test setups and procedures. While some dangers are specifically pointed out herein, it is impractical to list all necessary precautions.

Direct Comparison Method

For testing the ratio of a PT, the recommended method for field use is to use a calibrated PT to compare against the measured PT. Additional test methods for checking PT accuracy are outlined in Institute of Electrical and Electronics Engineers (IEEE™) Standard (Std.) C57.13-1993, Requirements for Instrument Transformers. Most PT tests outlined within IEEE™ Std. C57.13-1993 require specialized equipment.

A PT of known calibration is required for this method, called the reference PT. Connect the secondary side of the step-up PT to a variable autotransformer. The primary side of the step-up PT then is connected to the primary side of the reference and PT under test. The secondary side of the PT under test will be connected to a burden if it is desired to measure the ratio under load. Two high-precision digital voltmeters will be used to compare the output voltage of the reference PT and the output voltage of the PT under test. A scope or phase angle meter can be used to measure the phase angle. See the following figure.

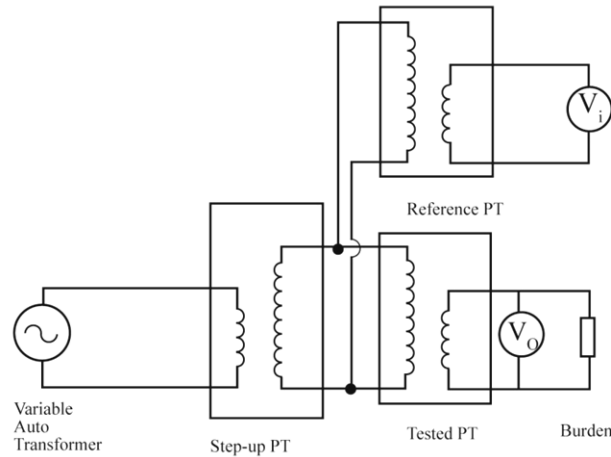

$$T_{\text{Test}} = \frac{V_i * T_{\text{REFERENCE}}}{V_t}$$

T_{Test} :	Turns ratio of the tested PT
$T_{\text{REFERENCE}}$:	Turns ratio of the reference PT
V_i :	Measured input voltage
V_o :	Measured output voltage

CAUTION: A dangerous voltage will be present on the high voltage terminals of both transformers.

The source high voltage always should be impressed across the primary side of the PT under test; otherwise, dangerously high voltages might be encountered.

Online Method

This method is performed with the plant equipment online and the PT energized. To perform this test, it is necessary to have a second PT (a reference PT) of a known ratio located on the same bus. Typically, this is a plant PT whose turn ratio has been verified by the methods listed above. Two high-precision digital voltmeters are used to compare the output voltage of the reference PT and the output voltage of the PT under test. A scope or phase angle meter can be used to measure the phase angle, if desired.

Polarity Check

There are several accepted testing methods to perform a polarity check on a PT.

Direct Current Voltage Test for PTs

To determine the polarity of a PT using this method, the following steps should be followed. See the following figure.

- Connect terminal 1 of the primary to terminal 1 of the secondary.
- Connect a direct current (dc) voltmeter across the primary of the PT.
- Connect a battery across the primary side of the PT to ensure that the voltmeter reads a positive value.
- Disconnect the voltmeter from the primary side of the PT and connect the voltmeter to the secondary.
- Check the results of the test by remaking and breaking the battery circuit. If both H1 and X1 terminals are of the same polarity, the voltmeter will kick in the positive direction on make and in the negative direction on break.

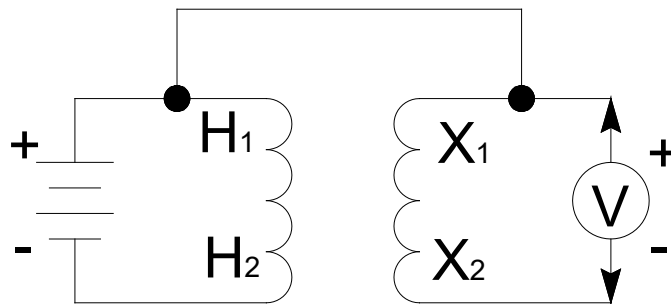

CAUTION: A dangerous voltage may be generated while disconnecting the battery from the transformer winding. The proper personal protective equipment should be used.

It is preferable to apply the battery voltage to the high-turn winding to minimize high-inductive kicks that might injure personnel or damage equipment. This is why the voltage is applied to the primary on a PT and secondary on a current transformer (CT).

Direct Comparison of Winding Voltages

To determine the polarity of a PT using the direct comparison method, use the direct comparison method for measuring ratio and use an oscilloscope to determine if signals are in phase.

Online Method

To determine the polarity of a PT using the online method, use the online method for measuring PT ratio and use an oscilloscope to determine if signals are in phase.

Appendix G

INSTRUMENT TRANSFORMER SECONDARY GROUNDING

Extracted from FIST 3-23, dated September 2000

Instrument transformer grounding is critical to ensure proper operation of the protection system and the safety of powerplant personnel. Refer to American National Standards Institute/Institute of Electrical and Electronics Engineers Standard C57.13.3, Guide for the Grounding of Instrument Transformer Secondary Circuits and Cases, for greater detail if needed.

1. Instrument transformer secondary circuits should be connected to ground at only one point. This holds true regardless of the number of instrument transformer secondary windings connected to the circuit. The reasons for grounding at a single point are as follows:
 - a. The flow of fault current through plant ground systems can cause potential difference at different ground points. If the instrument transformer secondary circuit is grounded at more than one point, this potential difference will result in flow of current through the relay, instrument, and meter coils. The results are instrument inaccuracies, relay misoperations, and possible destruction of relays. Also, high neutral conductor currents resulting from multiple ground connections can cause thermal damage to the neutral insulation.
 - b. The use of a single grounding point within a control panel facilitates the temporary removal and re-establishment of the ground connection when desired to test for insulation deterioration or spurious grounds in the instrument transformer secondary circuit.
2. The point of grounding in the instrument transformer secondary circuit should be at the first point of application. Grounding at the first point of application, rather than at the transformer, is preferred for the following reasons:
 - a. Instrument transformers, their enclosures, and connections are more capable of withstanding the effects of voltage rise than control board components.
 - b. The increased use of sensitive solid-state and microprocessor devices in instrument transformer secondary circuits requires that voltage levels in the control boards be limited.
 - c. It provides the maximum protection for personnel at the point where they are most apt to be exposed to circuit over voltages—the control board.

- d. The use of a single grounding point within a control panel facilitates the temporary removal and re-establishment of the ground connection when desired to test for insulation deterioration or spurious grounds in the instrument transformer secondary circuit.

Note: In some cases, the arrangement of secondary windings or devices in the circuit makes it necessary to ground at some point other than the control board to obtain correct equipment performance; however, all other instrument transformer secondary circuits that do not conform to the recommended grounding practices should be modified to be in compliance.

Appendix H

PROTECTION SYSTEM PRIMARY AND SECONDARY INJECTION TEST METHODS

Section 8 outlined the requirements for total plant protection system functional testing. Protection circuit function test must be performed on a periodic basis. The protection circuits include all low-voltage devices and wiring connected to instrument transformer secondaries, telecommunication systems, auxiliary relays and devices, lockout relays, and trip coils of circuit breakers. Protection circuits also may include all indicators, meters, annunciators, and input devices such as governors, exciters, and gate closure control circuits if required for the correct function of the protection system. It is essential to test the entire protection circuit, including wiring, and all connections from “beginning to end” to ensure integrity of the total circuit. Often, these tests are performed by dividing the individual protection components into segments and testing each segment separately. However, the protection system can be tested as a whole by injecting either primary or secondary test currents or voltages at the instrument transformers as described in this appendix.

Primary Injection

Primary injection testing is performed by injecting primary currents and/or voltages onto the primary windings of the current transformers (CTs) and potential transformers (PTs). A source(s) capable of supplying voltages and currents equal to normal and abnormal operation values must be available. Upon injecting currents and/or voltages, the instrument transformers then output secondary values to protective relays, enunciators, indicators, and other devices. As outlined in figure 1 of the block diagram in section 8 of the main document, all components connected to the outputs of the relays then are tested. This also allows the user to test for correct polarity of the system while also performing ratio checks on instrument transformers. Depending upon the primary voltage and current values and the need for de-energizing primaries, this method may not be feasible. Take extreme care when performing primary injection testing because the currents and voltages injected into the instrument transformers can be hazardous. Only trained, experienced, and qualified personnel should test protective relay systems.

CAUTION: The primary circuits must be de-energized, locked/tagged, and grounded out prior to beginning any primary injection testing.

Primary test sets are commercially available that are capable of reaching some standard operating voltages and currents. The Hydroelectric Research and

Technical Services Group, 86-68440, has a primary test set available for loan; contact 303-445-2300 for more information.

Primary injection testing is suited for the commissioning of new equipment, after a circuit modification, or periodic functional tests. Primary injection testing also will provide valuable information as to the saturation level of the instrument transformers.

Secondary Injection

Secondary testing is accomplished by injecting single-phase or three-phase currents and voltages into the current transformer or potential transformer secondary that would emulate the secondary outputs both during normal and abnormal conditions. Secondary voltages typically are 120 volts phase-to-phase, and secondary currents are typically 0–5 amperes (amps) for timed functions of the relays. Higher currents (20 plus amps) may be required for instantaneous fault trip tests. These values can be obtained easily using multiple power supplies or a single modern relay test set (also known as a secondary test set). With secondary injection techniques, a primary outage is not required; and risks are reduced due to lower required voltages.

The downside to this form of testing is that instrument transformers must be tested separately from the relay. The polarity of the system must be confirmed using multiple test methods to ensure that all components of the protection circuit are correctly interconnected. Extreme care must be taken to ensure that the polarity results at the CT/PT tests are used when testing relays. This form of testing also does not determine if the instrument transformers are becoming saturated when connected to the plant load and giving false information during normal operation; neither does it test them for correct ratios and correct outputs.

Therefore, separate tests must be performed on the instrument transformers when using secondary injection testing techniques.

Appendix I

ADJUSTMENT OF WESTINGHOUSE TYPE KD RELAYS

Bureau of Reclamation personnel have experienced considerable difficulty with Westinghouse Type KD relays due to inadequate contact restraint upon loss of restraint potential. When the relay is adjusted according to the manufacturer's instructions, the restraint in the contact opening direction is so slight that vibration or jarring of the switchboard panel will close the contacts, and they sometimes remain closed. This causes a problem on schemes where the restraint potential is obtained from the line (i.e., in a ring bus scheme) or when loss of main bus potential occurs (when restraint potential is obtained from the bus), since it is impossible to close the breaker under this condition. Present design practice is to provide overcurrent supervision of distance relays where potential is line connected. In older installations where overcurrent supervision is not provided, the existing relay adjustment instructions should be modified to ensure that the relays will rest when they are de-energized. Westinghouse relay engineers have provided the following supplementary instructions:

- If minimum voltage at the relay, for a fault at the balance point setting, is less than 30 volts secondary line-to-line, then the spring restraint should be adjusted as per pages 25 and 27 of I.L.41-491H for Type KD and KD-1 relays, or as per pages 24 and 25 of I.L. 41-491.4N for Type KD-4 and KD-41 relays. However, if with this adjustment the relay contacts fail to reset when relay is de-energized, the spring restraint should be increased only enough to hold the moving contact against the backstop while the relay is de-energized.
- Where minimum voltage at the relay, for a fault at the balance point setting, is 30 volts line-to-line or more, the spring restraint for both three-phase and phase-to-phase element may be set as follows:
 - Connect relay to Test No. 1, except reverse the voltage phase sequence by interchanging the connections to Brush 1 and Brush 2.
 - Adjust voltages V1F2F and V2F3F for 3.5 volts each.
 - Position the moving contact spring adjuster so that the moving contact just restrains against the backstop. This adjustment will make the three-phase unit characteristic somewhat nonlinear with respect to balance point voltage, but the effect is almost negligible at 30-volt line-to-line and above.
- There is one other possible problem due to loss of potential on these relays. If the relays are de-energized because of the tripping of remote

source circuit breakers, the contacts may momentarily close due to the transient decay of energy in the potential circuit of the relay. If it is desired to prevent tripping under such conditions where the relay can be de-energized without opening the “52 a” contact, the recommended solution is to use fault detectors as stated on page 3 of I.L. 41-491H and page 1 of I.L. 41-491.4N.

Appendix J

GENERAL ELECTRIC COMPANY RELAYS

Extracted from FIST 3-21, dated June 1991

General Electric Company Type RPM Relays

False tripping has been attributed to overtravel in a General Electric Type RPM timer relay. The cam assembly overtraveled while resetting, and this allowed the TU2 contact to close. This can happen just as the fault was re-established and allowed the backup distance relay to trip without delay.

Some newer RPM relays are provided with a cam to maintain the TU2 contacts closed, after its time delay, until the RPM is de-energized. When a long-time delay is required, the back edge of the cam is near the TU2 contacts at the reset position; and any overtravel during resetting can cause the cam to bump the TU2 contacts closed.

The photographs below show a type RPM relay with the setting of its TU2 near its maximum. Figure J-1 shows the position of the cam at reset. Figure J-2 shows the cam's position with the relay energized. Figure J-3 shows TU2 contact closed due to overtravel during reset.

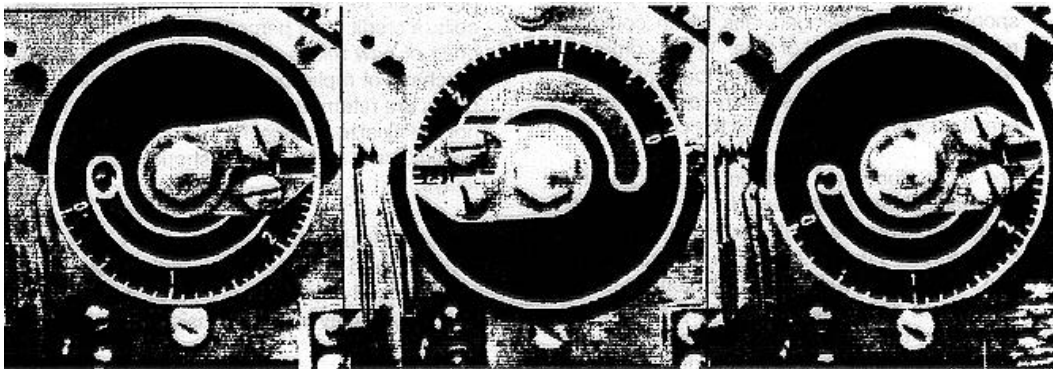

Figure 1

Figure 2

Figure 3

At locations where this is found to be a problem, a small portion of the cam's surface can be removed from the back edge. Only that portion of the cam that is causing the problem should be removed, since a shorter time delay setting may be required in the future.

All type RPM relays should be checked to verify that this problem does not exist.

Potential Problems with General Electric Type HFA, HGA, HKA, and HMA Relays

The following information was received in a letter dated October 15, 1973, from the General Electric Company, Installation and Service Engineering Department, Denver, Colorado.

“In 1954, a program was initiated to improve the mechanical and electrical properties of paper-based spools used for General Electric Type HFA, HGA, HKA, and HMA relay coils. Heat-stabilized nylon was selected for the spool material because its temperature characteristics made it well suited for Class A coils, and the material provided the desired improvement in electrical and mechanical properties. Manufacturing of HMA relays with the nylon spools started in 1955. After 3 years of successful experience, the change to nylon spools was implemented in HFA, HGA, and HKA relays in 1958.

“In the mid-60’s, a few failures of HMA coils utilizing the nylon spools for d-c applications were reported. As a result of these failures, an investigation was undertaken to determine the cause of the failures. It was found from this investigation that the heat stabilizing element of the nylon coil spool contained halogen ions which could be released over a period of time. When combined with moisture, the halogen ions form hydrochloric acid and copper salts, which could cause the eventual open circuit failure of the coils.

“The most significant contributing factor in the reported failures is high humidity. Other contributing factors are the small wire size used in HMA relays and in d-c relays, and the release of halogen ions is accelerated by d-c potential. Relay coils, which are continuously energized, are not subject to this phenomenon because the coil temperature is maintained considerably above ambient, thus minimizing the probability of moisture getting into the coil.

“After the spool material was changed to nylon in 1955–1958, a new material, Lexan, became available. Lexan has the desired chemical, mechanical, and electrical characteristics for use in spools. The change to the use of Lexan for spools was started in 1964 and completed in 1968. The first relay change was the HMA followed by the HGA, and HFA. Black was chosen for the color of the Lexan spools to make them distinguishable from the nylon. Since the initial reports of open circuited HMA coils, the failures of auxiliary relays have been very limited. However, recently one customer reported an accumulation of open circuit failures of a significant number of HGA relays with nylon spools which were used in X-Y closing circuits of breakers. As a result of this recent report and in keeping with our procedure of informing you of potential problems, we are bringing this matter to your attention, even though the overall rate of failure continues to be extremely low.”

Applications of HFA, HGA, HKA, and HMA relays in areas of high humidity, intermittent operation, direct current power, and with white nylon spools are discouraged; and facilities should consider replacing these coils or relays.

Further instructions regarding replacement relays or coils can be obtained from the General Electric Company.

Appendix K

RELAY SETTINGS CHANGE FORM

Protective Relay Setting Change Form

Regional Office: _____	Date: _____
Area Office: _____	Plant: _____
Location ID: _____	IEEE No. _____
Relay Designation: _____	Manufacturer: _____
Serial Number: _____	Style/Model No. _____
Application _____	

Old Setting: _____	Proposed Setting: _____
_____	_____

Reason for changing setting:

Additional Information: (Drawing numbers, calculations, firmware, etc)

Name of Person Requesting Change: _____

Engineering Review Performed by: _____ Date: _____

Setting Changed and Relay Tested By: _____ Date: _____