

Fish-holding-associated Stress in Sacramento River Chinook Salmon
(*Oncorhynchus tshawytscha*) at South Delta Fish Salvage Operations:
Effects on Plasma Constituents, Swimming Performance, and Predator Avoidance.

By

DONALD EDWARD PORTZ
B.S. (State University of New York, Albany) 1995
M.A. (University of Colorado, Boulder) 1999

DISSERTATION

Submitted in partial satisfaction of the requirements for the degree of

DOCTOR OF PHILOSOPHY

in

Ecology

in the

OFFICE OF GRADUATE STUDIES

of the

UNIVERSITY OF CALIFORNIA

DAVIS

Approved:

Committee in Charge

2007

Table of Contents	Page
List of figures and tables	v
Acknowledgements	vii
Abstract	x
Chapter 1 Fish Salvage Operations and Fish-Holding-Associated Stress	1
Introduction	2
Stress responses in fish	8
Collecting/Holding Tanks and Fish Conveyance Methods	11
Chapter 2 Evaluating chemo-physiological responses of juvenile Chinook salmon (<i>Oncorhynchus tshawytscha</i>) to different handling and salvage practices at large water diversions	16
Introduction	17
Materials and Methods	19
Results	26
Discussion	34
Chapter 3 Effects of handling and holding environments on swimming performance and kinematics of juvenile Chinook salmon (<i>Oncorhynchus tshawytscha</i>)	45
Introduction	46
Materials and Methods	50
Results	57
Discussion	66
Chapter 4 Predator avoidance ability and physiological stress response in juvenile Chinook salmon (<i>Oncorhynchus tshawytscha</i>): Effects of multiple acute stressors during salvage practices at screened water diversions.	76
Introduction	77
Materials and Methods	80
Results	86
Discussion	88

<u>Table of Contents (continued)</u>		<u>Page</u>
Chapter 5	Conclusions: The value of the functional continuum to examining fish salvage-related effects	94
Appendix 1	Figures and Tables	101
Appendix 2	Literature Cited	132

List of Figures and Tables

Figures

1. Schematic of the Tracy Fish Collection Facility, Tracy, California
2. Physiological responses to stressors
3. Cylindrical collecting/holding tank with lift bucket fish conveyance method
4. Fish removal method for the cylindrical collecting/holding tank
5. Oval collecting/holding tank with Pescalator[®] Archimedes-type fish lift
6. Fish removal method for the oval collecting/holding tank
7. Plasma cortisol concentrations for the oval holding tank and Pescalator[®] Archimedes-type lift along with corresponding control and standardized stress fish groups.
8. Plasma cortisol concentrations for the cylindrical holding tank and lift bucket along with corresponding control and standardized stress fish groups.
9. Plasma glucose concentrations for the oval holding tank and Pescalator[®] Archimedes-type lift along with corresponding control and standardized stress fish groups.
10. Plasma glucose concentrations for the cylindrical holding tank and lift bucket along with corresponding control and standardized stress fish groups.
11. Plasma lactate concentrations for the oval holding tank and Pescalator[®] Archimedes type lift along with corresponding control and standardized stress fish groups.
12. Plasma lactate concentrations for the cylindrical holding tank and lift bucket along with corresponding control and standardized stress fish groups.
13. Hematocrit levels for the oval holding tank and Pescalator[®] Archimedes-type lift along with corresponding control and standardized stress fish groups.
14. Hematocrit levels for the cylindrical holding tank and lift bucket along with corresponding control and standardized stress fish groups.
15. Osmolalities of oval holding tank and Pescalator[®] Archimedes-type lift experiments along with corresponding control and standardized stress fish groups.
16. Osmolalities of cylindrical holding tank and lift bucket experiments along with corresponding control and standardized stress fish groups.

17. Burst swimming raceway to film burst swimming speeds and startle responses with a high-speed camera at 500 pictures /s.
18. The startle response in juvenile Chinook salmon (*Oncorhynchus tshawytscha*) at rest and the preparation stage where the fish bends into a “C” shape.
19. Mean swimming velocity comparisons for within treatment groups and holding tank types with conveyance mechanisms and conveyance mechanisms alone.
20. Maximum swimming velocity comparisons for within treatment groups and holding tank types with conveyance mechanisms and conveyance mechanisms alone.
21. Mean swimming acceleration comparisons for within treatment groups and holding tank types with conveyance mechanisms and conveyance mechanisms alone.
22. Maximum swimming acceleration comparisons for within treatment groups and holding tank types with conveyance mechanisms and conveyance mechanisms alone.
23. Maximum angle of C-start for juvenile Chinook salmon in response to holding tanks and conveyance methods, control, and standardized stress comparisons.
24. Maximum swimming performance comparisons from the annular racetrack for within treatment groups and holding tank types with conveyance mechanisms and conveyance mechanisms alone.
25. Percent survival of predation challenge test for oval holding tank and Pescalator[®] Archimedes-type lift experiments.
26. Percent survival of predation challenge tests for cylindrical holding tank and lift bucket experiments.
27. Percent survival of predation challenge test comparisons for within treatment groups and holding tank types with conveyance mechanisms and conveyance mechanisms alone.

Tables

1. Hydromineral responses to holding tanks and conveyance methods
2. Mean and maximum swimming velocities for juvenile Chinook salmon in response to holding tanks and conveyance methods with control and standardized stress comparisons.
3. Mean and maximum swimming accelerations for juvenile Chinook salmon in response to holding tanks and conveyance methods with control and standardized stress comparisons.

Acknowledgements

Writing a dissertation can be a lonely and isolating experience, yet it is obviously not possible without the personal and practical support of numerous people that have assisted during the development and research stages of my graduate career. The journey was not always trouble-free, riddled with pitfalls and disappointments, but somehow I managed to persevere and learn so much about life along the way. I could never have completed this goal without the help, support, guidance and efforts of many people.

First, I would like to thank my esteemed mentor Dr. Joseph Cech, Jr. for instilling in me the qualities of being a good scientist and encouraging me to pursue my research endeavors. This dissertation would not have been possible without his expert guidance, generous time, and commitment while developing my research skills and assisting my scientific writing. His infectious enthusiasm for education and science has been a major driving force through my graduate career at the University of California, Davis.

I am also very grateful for having an exceptional doctoral committee and wish to thank Drs. Peter Moyle, Charles Liston, and Joseph Cech, Jr. for their continual support and encouragement, not to mention providing valuable suggestions and contributions to this dissertation.

I would also like to express my sincere gratitude for having received so much support from numerous research assistants, especially from the University of Colorado at Boulder and the Bureau of Reclamation: Ella Ahlers, Eric Best, Jamie Betker, Spencer Brennan, Alex Daniels, Brent Eberhard, Lane Forrer, Mike Harmeson, Chuck Hueth, Jazzmin Jenkins, Judy Lyons, Andrew Martinez, Andrew Montaña, Dave Moore, Dave Mueller, Norm Ponferrada, Sherri Pucherelli, Dustin Reed, Mike Rouse, Steve Ryan,

Juddson Sechrist, Zak Sutphin, Timber Toste, Dustin Thompson, Matthew Trese, Naomi Yoder, Juan Zamora, Kirsten Zeh, and Katherine Zehfuss. I am extremely grateful for the assistance of Norm Ponferrada who pulled many all-nighters analyzing plasma samples, Juan Zamora for keeping the viruses off of my computer and painstakingly watching thousands of frames of salmon swimming video, and Chuck Hueth and Matthew Trese for acting as my right-hand men in Denver. I owe a special note of gratitude to Jason Black and Marty Poos for assisting with construction of the holding tanks at the Hydraulics Laboratory and to Brent Mefford, Cliff Pugh, and Jerry Fitzwater for their engineering assistance and getting me back up and running after ‘minor’ disasters threatened to end my experiments. I am also grateful for the hospitality and support of Andrew Montaña who lent his couch to me as a place to crash while away in Denver doing research for months at a time. I would like to also thank Steve Hiebert, my supervisor in Reclamation’s Fisheries and Wildlife Resources Group, for his support and more importantly patience during the last five years while I was consumed with my doctoral research.

Many people on the faculty and staff of the University of California, Davis assisted and encouraged me in various ways during my course of studies, but I am especially grateful to the staff of the Department of Wildlife, Fish, and Conservation Biology. I would also like to express my appreciation to Coralie Munro and Alejandro Esteller Vico of UC Davis’ Clinical Endocrinology Laboratory for cortisol analyses. My graduate studies would not have been the same without the social and academic challenges and diversions provided by all my student-colleagues in the Graduate Group

in Ecology. I am particularly thankful to my lab mates: Scott Lankford, Peter Allen, Christa Woodley, Bob Kaufman, Wes Dowd, and Tim Mussen.

I extend many thanks to my CHTR colleagues, Bob Fujimura, Virginia Afentoulis, Geir Aasen, and Jerry Morinaka for assisting with the development of the research design and providing constructive suggestions along the way. I am extremely grateful to Kurt Brown and Kevin Niemela of the Coleman Nation Fish Hatchery for providing Chinook salmon for this research.

I would like to thank the Bureau of Reclamation's Tracy Area Office, California Fly Fishers Unlimited, Stockton Sportsmen's Club, and the Marin Rod and Gun Club for financial support. I am deeply indebted to Ron Silva and Charles Liston for entertaining my research ideas and providing a source of funding. Without their assistance none of this would have been possible.

Finally, the acknowledgements would not be complete without a heart-felt thanks to the people to whom I owe everything I am today, my parents. Their unwavering faith and constant source of support is what has shaped me to be the person I am today.

Abstract

Operations of fish salvage facilities at major diversions in the Sacramento-San Joaquin Delta require proper screening, daily collection, and holding of fishes, and their transport downstream. Exposure of fishes to environmental stressors, such as capture and handling, can be a great concern, in that extreme or prolonged stressors may plague fish performance and overall health. We assessed chemo-physiological changes and compromised performance over a functional continuum in juvenile Chinook salmon (*Oncorhynchus tshawytscha*) that were exposed to simulated salvage-tank-related stresses. These assessments covered biochemical (plasma constituents), performance (maximum swimming performance, burst swimming, and C-start responses), and ecological measurements (predator avoidance), in evaluating the physiological condition of control, standardized stress, and salvage tank treatment (oval holding tank with Pescalator[®] Archimedes screw lift and cylindrical holding tank with lift bucket) fish under five holding durations. Our goal was to determine whether collecting/holding tank designs, conveyance methods, and holding duration significantly contributed to the fishes' direct or indirect mortality.

Results indicate that stress is functionally interrelated across biochemical, organismal, and ecological levels of organization. More specifically, treatment groups that demonstrated significant plasma constituent stress responses also showed a decreased maximum swimming performance and body bending in C-start startle responses, although no statistical differences were apparent among our control, standardized stress, and most treatments during burst swimming speed tests. Finally, striped bass (*Morone saxatilis*) predators captured stressed salmon disproportionately to unstressed salmon.

Comparing salvage tank treatments, salmon exposed to the cylindrical holding tank with lift bucket had plasma constituent levels that more closely resembled the control fish and performed better in our challenge tests than did those in the oval holding tank with Pescalator[®], the most stressful component of the collecting-holding-conveyance process. Interestingly, we found no significant differences among holding durations. Our results provide a scientific basis for using a straightforward, inexpensive stress-assessment method (e.g., annular-racetrack maximum swimming performance) for salvaged, juvenile Chinook salmon. They also support the examination of stress responses across a functional continuum, rather than merely observing potentially isolated chemo-physiological response alone, when attempting to understand a fish's response to stress at ecological levels.

Chapter 1

Fish Salvage Operations and Fish-Holding-Associated Stress

1.1 Introduction

During the past twenty-five years, several fish species in the Sacramento-San Joaquin Delta, California have declined in abundance, including Sacramento River winter-run Chinook salmon (*Oncorhynchus tshawytscha*), delta smelt (*Hypomesus transpacificus*), and striped bass (*Morone saxatilis*). Water diversions are suspected of being one of the major causes of declines in fish populations throughout California (Brown and Moyle 1993, Bennett and Moyle 1996, Danley et al. 2002). The U.S. Bureau of Reclamation's Tracy Pumping Plant along with the state's Harvey O. Banks Pumping Plant, divert approximately 24% of the Delta's average annual inflow (Mitchell 1996). The large water volume that passes through these pumps can create flows that attract fishes and results in an increased concentration of fishes in the vicinity of the pumping facilities (Arthur et al. 1996, Bennett and Moyle 1996, Brown et al. 1996). These diversions are protected by upstream fish salvage facilities. Federally and State-listed threatened and endangered fish species, sport fishes, and other declining are frequently captured during salvage operations. Operations of the south Delta State and Federal fish salvage facilities in California require daily collection and holding of fish, and transport of these fish back to the Sacramento-San Joaquin River Delta, away from the facilities. However, collecting, holding, and transport methods associated with entrainment of the fishes may cause harm to fish that salvage facilities are attempting to minimize.

The U.S. Bureau of Reclamation's Tracy Fish Collection Facility (TFCF) consists of a system of louvers, bypasses, and collecting/holding tanks to reduce associated fish loss of its pumping operation (Fig. 1). This fish diversion is intended to redirect fishes from entrainment and then release them back to the Sacramento-San Joaquin River Delta

relatively “unharmful” downstream of the influence of the pumps. The TFCF is located at the start of the Delta-Mendota Canal 4 km northeast of the Tracy Pumping Plant and 15 km northwest of Tracy, California. More than 1.85 billion cubic meters of water are diverted south annually in the Delta Mendota Canal for water users by the Tracy Pumping Plant, not including those exports by the State of California’s Harvey O. Banks Pumping Plant. Water is drawn through the Delta into the Old River where it passes through the TFCF and into the Tracy Pumping Plant at rates up to 142 m³/s. Fish that are attracted by flows or actively carried downstream are entrained into the fish collection facility and many are salvaged before reaching the Tracy Pumping Plant. Fish screening consists of two sets of vertical metal louvers (primary and secondary) that serve as behavioral barriers to fish. Water is strained through louvers aided by downstream pumps and into a series of four pipes to a secondary set of louvers where it is screened once more. Acting as a behavioral barrier, fish attempt to avoid the louvers as they move downstream and become confined by the constricting channel where they are swept into 15-cm wide bypass slots. Once fish have entered the bypasses, they are delivered into one of four collecting/holding tanks and are collected for up to 8-12 hours depending on the type and density of fish. Fish are collected and held for up to 24 hours awaiting transport and release. Holding durations vary seasonally, however, collected fish are mandated to be held for no more than 8 hours in spring when Delta smelt may be present, and for no more than 12 hours in the winter and spring when juvenile Chinook salmon may be present. Other times throughout the year fish may be held up to 24 hours depending on fish densities. After the holding duration, water levels are lowered while fish remain in the periphery of the tank; contained there by a 2.4-m diameter, wire mesh,

cylindrical screen positioned in the center. A lift bucket is lowered into a recessed position in the center of the holding tank and the 2.4-m diameter screen is pneumatically lifted so that collected fish can be flushed into the lift bucket and transferred into a hauling truck for transport back to the Sacramento-San Joaquin River Delta.

The TFCF was originally designed in 1956 to divert downstream migrating smolt Chinook salmon from exported flows and was not intended to divert and salvage the myriad of fish species entrained by pumping practices today. To date, more than 50 species have occurred at the TFCF with more than 5 million fish collected annually (Johnson Wang, TFCF, Tracy, California, personal communication). The high number of species and total numbers, along with the documented declining abundance of several fish species, are prompting TFCF improvements, including more efficient operational methods.

Evaluations and improvements of both State and Federal fish salvage facilities have been ongoing for a number of years, though emphasis has been more on facilities themselves rather than operations for handling, transporting, and release of fishes (Liston et al. 2000). Efforts by California Department of Fish and Game have demonstrated problems with survival of salvaged fishes after transport to the release site and Reclamation researchers have contributed to the understanding of survivorship and injury of fishes associated with the collecting/holding tanks at the TFCF (Raquel 1989, Karp and Lyons 2007). These studies, and ongoing technological advances in concepts related to fish holding, indicate an important need for accelerating and expanding studies at the two salvage facilities. Research and monitoring plans have been instituted to investigate

the consequences that these water diversions are having on Sacramento-San Joaquin River Delta fish fauna and ways to minimize their negative impacts (Raines et al. 2001).

Fish losses due to entrainment are reduced with improved salvage operations, and the success of these operations is dependent on the survival of louvered and screened fishes. Measuring the acute physiological stress and potential direct and indirect mortality experienced by fishes during different components of the salvage process is vital to understanding negative impacts the process may have on fish. Direct effects are considered as those that affect the fish's physiological function, endocrine response, or cellular response, whereas, indirect effects function at the population and community level (Barton and Iwama 1991). The response to stressors causes an extension of a fish's physiological condition beyond the normal state to a point that, if extreme or prolonged, may compromise its chances for survival (Seyle 1973, Barton et al. 2002). Extreme or prolonged exposure of fishes to stressors, such as capture and handling may reduce fish performance (i.e., growth, metabolism, reproduction, immune system, and predator evasion) and overall health (Barton et al. 2002), adversely affecting population size and sustainability. Abated performance due to sublethal stresses may increase susceptibility of these fishes to predators (indirect mortality; Olla et al. 1992, Strange and Cech 1992, Mesa 1994, Mesa et al. 1994). For example, predation by striped bass has been identified as a major source of mortality for Chinook salmon entrained at the State's Harvey Banks Pumping Plant (Arthur et al. 1996, Brown et al. 1996, Moyle 2002).

Depending on its intensity and duration, stress may affect fish at all levels of biological and ecological organization. Responses to stress are often thought to be interrelated functionally from biochemical, organismal, to population and community

levels of organization (Wendelaar Bonga 1997, Barton et al. 2002). To fully comprehend and value an organism's response to stress at ecological levels, it is important to examine stress responses across the whole-body rather than merely observing potentially isolated chemo-physiological responses. One of the most broadly used approaches to evaluating physiological responses of fish to environmental stressors is measuring blood plasma constituents such as cortisol, lactate, glucose, osmolality, chloride, sodium, and potassium (Pickering 1981, Barton and Iwama 1991, Iwama et al.1995). However, some of these reflect a normal response to [less extreme or less prolonged] stressors from which a fish can quickly recover (Wendelaar Bonga 1997, Barton et al. 2002), an assessment of fish well being and performance should not be restricted to an examination of internal chemo-physiological changes, alone. Thus, a more complete assessment should include an examination of chemo-physiological changes and compromised performance over a functional continuum, covering proximate (e.g., blood plasma constituents), performance (e.g., maximum swimming performance, burst swimming speed, and C-start responses), and ecological (e.g., predator avoidance) measurements. If biochemical changes are not linked to organism-level responses, the validity of applying such measures to population or ecosystem levels becomes remote. Measuring single stress responses at various levels of biological organization may be valuable for achieving specific goals but lack ecological realism. Therefore, a combination of physiological changes in plasma constituents and the ability to perform under controlled challenge tests should assess more accurately stress-related effects of fish salvage. Finally, the more complete information can be used to identify the most stressful

components of the salvage operation, thereby helping to design alternative salvage methods or equipment to increase the survival of entrained fishes.

The goal of this study was to determine whether collecting/holding tank designs and conveyance methods [from holding tank to transporting vehicle] during the collection process at south Delta fish salvage facilities significantly contributed to the fishes' direct or indirect mortality through acute physiological stresses. Ultimately, the results of this research could decrease harmful effects of entrainment and holding, thereby decreasing the incidental take of fishes. In addition, information on the effects of the salvage process on swimming and predator-evading behavior could help to change operational procedures to prepare salvaged fishes better, before release into the Sacramento River where predators await. Predation has been noted as one of the most significant losses of salvaged fishes (Liston et al. 1994, OCAP Biological Opinion 2005, Kimmerer and Brown 2006). Furthermore, an investigation into whether stress effects are conserved across a functional continuum resulting in compromised performance at various levels of biological and ecological organization was assessed. By measuring stress responses (i.e., chemo-physiological changes) along with performance at various biological levels, the ecological relevance can be predicted. Although stress assessments at specific levels of biological organization have been conducted repeatedly in the past, measuring a functional continuum of stress and relevant performance-related responses has not been done previously. Use of the functional continuum concept of biological indicators should increase the predicted value of stress effects on fish populations.

Specifically, this research aimed to compare changes in plasma constituents, swimming performances, and predator avoidance abilities associated with holding and

handling stresses of juvenile Sacramento River Chinook salmon (ca. 100 mm TL). A key question was: how do collecting/holding tanks, transfer designs, and duration of holding physiologically affect juvenile Chinook salmon and their vulnerability to striped bass predation? We hypothesized that the cylindrical collecting/holding tanks and lift bucket significantly alter juvenile salmon plasma constituent levels, significantly decrease their burst swimming performance, and significantly increase their predator-induced mortality, compared to those of fish sampled immediately upon entrainment and those collected in an oval holding tank with a Pescalator[®] Archimedes lift. Furthermore, we hypothesized that juvenile Chinook salmon held for extended periods of time (i.e., >4 h, but ≤24 h) will show plasma constituents, swimming abilities, and predator-induced mortality statistically indistinguishable during this duration.

1.2 Stress responses in fish

Teleost fishes have primary, secondary, and in some cases tertiary stress responses (Fig. 2). The primary stress response involves the release of catecholamines (e.g., epinephrine, norepinephrine) into the circulatory system from chromaffin cells and the stimulation of the hypothalamic-pituitary interrenal (HPI) axis to release corticosteroids (e.g., cortisol) from the interrenal tissue (Mazeaud and Mazeaud 1981, Randall and Perry 1992, Wendelaar Bonga 1997, Mommsen et al. 1999, Barton et al. 2002). The release of catecholamines into the bloodstream is rapid (Randall and Perry 1992), while cortisol synthesis has a temperature-related delay of minutes (Wedemeyer et al. 1990, Lankford et al. 2003). Due to invasive, and thus stressful, blood sampling procedures, temporal characteristics make it difficult to use plasma catecholamine

concentrations as a measurement of stress in small, wild fishes. In contrast, the inherent delay of cortisol synthesis and release makes it a more useful measurement.

Primary stress responses trigger sequential secondary responses, (e.g., increases in plasma glucose and lactate concentrations, hematocrit, heart rate, gill blood flow, metabolic rate; decreases in plasma chloride, sodium, potassium, liver glycogen, and muscle protein) in teleosts (Pickering 1981, Mommsen et al. 1999, Barton et al. 2002). In freshwater and marine fishes, plasma glucose and hemoglobin concentrations, and hematocrit may increase over a 15-minute to more than a 4-hour period in response to capture, handling, and transportation-related stresses (Robertson et al. 1988, Frisch and Anderson 2000, Grutter and Pankhurst 2000). Secondary responses often remain for longer periods of time compared to the catecholamine and corticosteroid increases, and include mobilizing fuels to meet increased energy demands. Hyperglycemia after stress results, in part, from glycogenolysis stimulation from catecholamines to satisfy increased energy demands for a “flight or fight” response (Mazeaud and Mazeaud 1981). Brief struggling behaviors and prolonged swimming are known to decrease blood flow to the gut (Holmgren et al. 1992, Farrell et al. 2001b) and may reduce nutrient absorption, thereby decreasing future available fuel reserves. In addition, catecholamines function to regulate some cardiovascular and respiratory functions, including increased branchial blood flow, gill permeability, and lamellar recruitment (Booth 1979, Randall and Perry 1992, Wendelaar Bonga 1997). The resulting increase in gas exchange also is associated with increased gill permeability to water and some ions. This can be manifested as a gain in water and loss of small ions from the blood of freshwater fishes and as a water loss and ion influx for marine fishes (Mazeaud et al. 1977, Wendelaar Bonga 1997).

Cortisol also induces a wide range of secondary physiological responses in fishes. These include stimulation of metabolic and osmoregulatory responses, and immunosuppression after recognition of an actual or perceived stress (Barton and Iwama 1991). Cortisol is essential to long-term maintenance of hyperglycemia after catecholamine effects have subsided (Barton and Iwama 1991, Mommsen et al. 1999). Cortisol also upregulates adrenergic receptors on erythrocytic membranes (Nikinmaa et al. 1984, Nikinmaa 1986). The binding of epinephrine to these receptors facilitate ionic exchanges with the plasma, preserving hemoglobin's oxygen affinity (Nikinmaa 1986). Non-specific immune function is extremely important serving as a first line of defense, and can be suppressed as a result of increased corticosteroids in the blood (Yin et al. 1995, Clearwater and Pankhurst 1997, Montero et al. 1999, Ortuño et al. 2001).

With chronic stress (stress that persists over a long period of time), secondary responses may cascade ultimately to tertiary stress responses, which include decreased growth rate, metabolic scope for activity, disease resistance, and reproductive capacity, as well as altered behavior and survivability (Wedemeyer et al. 1990, Barton and Iwama 1991, Mommsen et al. 1999). The extent of tertiary responses is related to the severity and duration of the stressor (Lankford et al. 2005)

Collecting/holding tank design may also stress the contained fish, compromising survival, by affecting water quality, fish density and confinement, and agonistic interactions and predation (Portz et al. 2006). Fortunately, many design-related factors influencing stress in the detained fish are, to some degree, controllable by engineers and biologists. Stress associated with handling during transfer in and out of these collecting/holding tanks may also be severe with both immediate and long-term effects.

Handling and stress tolerance depends upon the species, life stage, genetic background, and behavior of the held fish (Woodward and Strange 1987, Barry et al. 1995, Barton and Iwama 1991). Some species may be unusually sensitive to stress (Clearwater and Pankhurst 1997). Many fishes survive exposure to stressors, but later die of disease or osmotic dysfunction (Mazeaud et al. 1977). Therefore, holding containers and transfer mechanisms that minimize additional stress to already compromised fish should decrease debilitating effects on them.

Some additional stresses on fishes held for relatively short durations include predation, cannibalism, and agonistic interactions. These interactions must be effectively managed, keeping losses and damages minimized and stresses at low levels so that immunological function is not impaired (Pickering and Pottinger 1989, Pottinger and Pickering 1992, Kubitza and Lovshin 1999). Negative interactions between fishes in collecting/holding tanks can result from intraspecific and interspecific competition and predation. Fishes screened and/or salvaged at electrical power plants, irrigation diversions, and municipal water facilities are often commingled with larger conspecifics and predators (Fausch 2000). The presence and perceived threat of these fishes may have detrimental stress effects (Berejikian et al. 2003, Chang and Liao 2003).

1.3 Collecting/holding tanks and fish conveyance methods

Declining fish numbers has elevated concern for fish survival when holding fishes for short durations, whether as bycatch on commercial fishing vessels, sport fishing live-wells, stocking programs, or in this case, fish salvage facilities associated with large

water diversions (Pankhurst and Sharples 1992, Pedersen and Amble 2001, Cooke et al. 2002). This concern has led to innovations in fish holding tank designs, reassessment of designs already in use, changes in the manner that fishes are transferred to these tanks, and their treatment during the holding period. However, physiological constraints and behavioral characteristics of held fishes have been frequently overlooked when designing fish holding structures. Understanding biological processes that occur while fishes are held in tanks and implementing optimal holding methods should decrease stress and increase survival.

Cylindrical collecting/holding tank with lift bucket

The current TFCF holding tank and lift bucket conveyance method may have negative effects on salvaged fish, such as abrasion by vegetative debris carried in from the Delta, and stress from high swirling velocities and putative harsh transfer due to high fish densities, via a lift bucket from the cylindrical holding tank to a hauling truck. A laboratory simulation of the TFCF cylindrical collecting/holding tank was constructed from a fiberglass panel tank (Red Ewald, Inc.) and epoxy coated. The TFCF tanks are epoxy coated to prevent fish injury from contact with concrete's abrasive surface. This simulation was constructed to specifications of the recessed, cylindrical holding tanks at the TFCF including center screens and lift bucket, except it was 2 m high instead of 4.7 m (Fig. 3). The shorter tank simulation closely approximates the hydraulic conditions of the TFCF tanks, while decreasing construction costs and laboratory safety concerns. Holding-tank water depths at the TFCF are tidal-dependent and range over 0.6-2.1m (mean: 1.7 m) with flows ranging over 0.028-0.340 m³/s (mean: 0.226 m³/s). The

simulated cylindrical holding tank was operated at the USBR Hydraulics Laboratory, Denver Federal Center, Colorado using a 100-h.p. centrifugal pump on a recirculating 946,353-l water reservoir, at the same mean water depths and flows measured in the TFCF tanks.

The recessed, cylindrical holding tanks at the TFCF entrain mainly fish, vegetative debris, and refuse carried in by attractant pump flows (Boutwell and Sisneros 2006). These materials flow via the louver bypasses through a 50.8-cm diameter pipe to one of four, 6.1-m diameter holding tanks entering them tangential to their outer wall. Water swirls around the cylindrically shaped holding tanks in a counterclockwise direction at a tidal-dependent height and drains through a centered, cylindrical, woven-wire screen (2.4-m diameter, 4.6-m high with 4-mm lattice openings; Fig. 3). Fish and debris remain on the outer annular area of the screen until the end of a collection period (Fig. 4). The tank influent water is diverted to another holding tank and the remaining water is drained through the screen, until it reaches a 55-cm depth (i.e., vertical height of the solid band on the bottom of the screen), maintaining >2,000 l of water with the collected fish before lifting the screen. Upon pneumatically lifting the 110-mm-high screen, the fish and other collected material are flushed under the screen towards the drain along a sloped floor into a pre-positioned, recessed 1890-l lift bucket (Figs. 3 & 4). Collected water and contents are conveyed to a 7,570-l tanker truck, and the salvaged contents of the lift bucket are released through a 25.4-cm outlet opening. In the laboratory, the simulated cylindrical holding tank was emptied into a simulated “lift” bucket through a 25.4-cm outlet opening. No vegetative debris or refuse was included in these simulated holding tank studies.

Oval collecting/holding Tank with Pescalator[®] Archimedes-type lift

A prototype above-ground oval holding/collecting tank with a Pescalator[®] Archimedes screw lift was designed to replace the aging and existing recessed cylindrical collecting/holding tank system (Fig. 5). Some design advancements inherent to the oval holding tank include traveling screens to remove debris, controllable water depths and velocities using external weirs located on the elongated sides, and different velocities around the tank due to its near-elliptical shape. The oval holding tank has a 1.05-m sidewall height with a 0.62-m wide channel. The outside length of the tank is 9.07 m, and its width is 3.98 m. Water enters the tank at one of its turns from a 100-h.p. centrifugal pump and travels clockwise along the straight section across a 4.5-m perforated plate section with height control weirs located behind. The water continues to travel around the tank to the other straight section where traveling screens remove vegetative and other debris. Behind the traveling screens are another group of weirs to control tank water depth and serve as a drain for the incoming water. Fish are accumulated in the tank, and flows are diverted to another tank when the collection period has ended. Four 0.3 x 0.3-m gates, one at each end of the straight section of the tank, are opened and fish are flushed into channels within the center of the oval tank to the mouth of the Pescalator[®]. The Pescalator[®] Archimedes-type lift consists of a screw inside a hollow pipe and can be thought of as an inclined plane wrapped around a cylinder (Fig. 6). As the bottom end of the Pescalator[®] tube turns, it scoops up a volume of water and fish from the center of the oval holding tank. Once water has entered the mouth of the Pescalator[®], it moves up in the spiral tube as the shaft turns, until it pours

out from the top of the tube and into a fish hauling truck for release (Fig. 6). The Pescalator[®] Archimedes screw lift has been engineered to remove fish from the center of the oval tank and may transfer salvaged fish more carefully, without air exposure, to a fish hauling truck (Conte 2004) and have the potential to transfer fish without inflicting significant biological damage (McNabb et al. 2003).

Chapter 2

Evaluating chemo-physiological responses of juvenile Chinook salmon (*Oncorhynchus tshawytscha*) to different handling and salvage practices at large water diversions

2.1 Introduction

Salvaged fish are subjected to a variety of handling and transport related stress as part of normal salvage operations. Acute disturbances cause detectable physiological changes that can be useful indicators of the degree of stress experienced by fish during salvage. As mentioned in Chapter 1, these physiological changes are categorized as primary, secondary, and tertiary stress responses. Primary responses include the release of catecholamines and corticosteroids which elicit secondary responses consisting of changes in plasma hydromineral, metabolite, and hematology (Wedemeyer et al. 1990, Baton and Iwama 1991, Barton et al. 2002). One of the most broadly used approaches to evaluating physiological responses to environmental stressors is measuring circulating levels of plasma cortisol, a primary response hormone, and secondary response plasma constituents: lactate, glucose, osmolality, chloride, sodium, potassium, and hematocrit (Pickering 1981, Barton and Iwama 1991, Iwama et al. 1995). Most studies of stress in fish have considered only the primary and secondary responses (Carragher and Rees 1994). Much of our present understanding about physiological responses of fish to stress comes from studying primary responses of the hypothalamic-pituitary-interrenal axis and subsequent secondary effects (Reid et al. 1998, Mommsen et al. 1999). Due to their wide use as stress response indicators, these plasma constituents may be compared among different treatments, fish species, or life stages.

Counteracting a stressor is an energy consumptive process, hence fish must make physiological adjustments to mobilize and utilize energy reserves, and increase oxygen availability to tissues to meet metabolic demands. Catecholamines are responsible for the immediate mobilization of energy stores during stress by glycogenolysis (Mazeaud and

Mazeaud 1981, Wendelaar Bonga 1997, Barton et al. 2002). Corticosteroids, such as cortisol, also function in glycogenolysis and maintaining elevated plasma glucose levels for metabolic reactions providing energy to overcome stressors (Barton and Iwama 1991, Vijayan et al. 1997, Mommsen et al. 1999). Therefore, actions of the primary stress response can both directly or indirectly affect secondary stress responses, including metabolism, hydromineral balance, and hematology. Lamellar blood flow and gill permeability are increased, providing more oxygen to meet metabolic demands (Booth 1979, Wendelaar Bonga 1997, Cech 2000). Such changes in gill mechanisms can lead to a temporary osmotic imbalance due to the osmotic uptake of water and diffusive loss of hydrominerals across gill membranes of freshwater fishes. Therefore, increased fluxes in water, sodium, chloride, and potassium are likely with stress-induced gill permeability (Wendelaar Bonga 1997, Cech 2000, Moyle and Cech 2004).

Plasma lactate concentrations often increase due to strenuous muscle activity or struggling during stressful encounters (Milligan 1996). Lactate is produced as an end-product of glycolysis in white muscle following these activities. In salmonids, it is believed that up to 90% of the lactate produced is retained in the muscle to be used as *in situ* glycogenesis (Milligan 1996, Sharpe and Milligan 2003). Lactate that is not converted to glycogen to replenish energy stores must be cleared from muscle. In addition, the H^+ and lactate concentrations create diffusion gradients that transport H^+ and lactate out of muscle and into plasma (Milligan and Farrell 1991, Sharpe and Milligan 2003). Unlike the immediate spike within muscle, plasma lactate concentrations elevate gradually after strenuous muscle activity, peaking 2-4 hours later (Milligan and McDonald 1988, Milligan 1996). Although, plasma lactate concentration increases in

stressed fish are well documented, it is not well understood how catecholamines and corticosteroids directly affect plasma lactate concentrations (Milligan 1996).

To minimize harmful effects (including mortality) of fish salvage, it is necessary to quantify stress associated with different components of the collection and holding process. The objective of this study was to assess physiological responses (i.e., plasma cortisol, lactate, glucose, osmolality, chloride, sodium, and potassium concentrations, and hematocrit) of juvenile Chinook salmon to different salvage processes (i.e., collecting/holding tank type and conveyance method) and holding durations. Our focus was to assess whether collecting/holding tanks, transfer designs, and duration of holding physiologically affect juvenile Chinook salmon (ca. 100 mm TL; see Chapter 1). We hypothesized that cylindrical collecting/holding tanks with a lift bucket, currently used to transfer fish from holding tank to transporting vehicle, significantly alter juvenile salmon plasma constituent levels compared to those of pre-experiment (control) fish and those collected in an oval holding tank with a Pescalator[®] Archimedes lift. Furthermore, we hypothesized that juvenile Chinook salmon held for extended periods of time (i.e., >4 h, but ≤24 h) have statistically indistinguishable plasma constituent levels.

2.2 Materials and Methods

Source and Care of Fish

Sacramento River Chinook salmon (*Oncorhynchus tshawytscha*) used in this study are commonly entrained and of special concern to the Tracy Fish Collection Facility (TFCF). Chinook salmon were obtained in 2005 and 2006 from the Coleman National Fish Hatchery (Anderson, California) and transported to the U.S. Bureau of

Reclamation's Hydraulic Laboratory (Denver, Colorado). Juvenile fall-run Chinook salmon were considered surrogates for winter-run Chinook salmon, which are of significant conservation value (i.e., federally and state listed endangered species) and not available in sufficient numbers for this experiment. Salmon were maintained in 757-l circular tanks equipped with an aerated, partial recirculating water system to deliver water continuously along with dechlorinated, air-equilibrated municipal water. Water temperatures were maintained at 18°C and flow direction was altered weekly for symmetrical muscular development while swimming into the gentle current. Fish were held under a natural photoperiod (38° N latitude) with natural and halogen light, and were fed BioOregon (BioOregon Inc., Longview, Washington) semi-moist pellets at 1.5-2% body weight per day.

Treatment and control groups of salmon were marked with implanted, white microspheres on caudal and anal fins with a high pressure needle (Photonic tagging; New West Technology, Arcata, California). Fish were tagged to differentiate treatments for a subsequent predation study (Chapter 4), and were allowed to recover for at least two weeks after marking before use in experiments. This method of fish marking was less severe/invasive, compared with other techniques such as fin clipping or Floy tagging, and presumably did not affect the salmon's stress response (Hayes et al. 2000).

Groups of 20 fish (103 ± 7 mm, mean \pm standard deviation, TL in 2005 and 105 ± 6 mm TL in 2006) were transferred to 87-l circular, polyethylene tanks 3 days before an experiment to acclimate to Hydraulic Laboratory water conditions and be in close proximity to the experimental holding tanks where handling stress responses were evaluated. Fish carrying the same mark were held in one of four randomly selected 87-l

tanks (i.e., 2 control groups, 1 standardized stress group, and 1 treatment group) under constant water flow at $19.5 \pm 1^\circ\text{C}$ throughout the duration of the study from February through August 2005 (Experiment 1) and April through August 2006 (Experiment 2). Fish were fed once daily in the staging area, except for 24 hours before experimental use.

Experiment 1: Oval collecting/holding tank and Pescalator[®] Archimedes-type lift

Plasma data were evaluated in 2005 for each experimental group (control fish, standardized stress fish, and treatment fish from the oval holding tank, oval holding tank and Pescalator[®] under different holding durations within the tanks: 4 h, 6 h, 8 h, 12 h, 24 h, and for the Pescalator[®] independently). The oval holding tank flows ($0.226 \text{ m}^3/\text{s}$) and weir heights were set, and fish were inserted into it by gently submerging the 87-l tank and allowing the fish to swim out. To separate stresses inherent in components of the collection/holding process, the experiment was divided into three major parts: the oval holding tank and Pescalator[®] together; the oval holding tank alone; and the Pescalator[®] alone (Fig. 3). Fish were collected and sampled after they were held in the oval holding tank for a randomly selected duration (i.e., random draw). For oval holding tank and Pescalator[®] together assessments, fish were removed from the tank by the Pescalator[®] screw lift and conveyed into a 1500-l, cylindrical plastic tank with an internal crowder net making the fish readily accessible. While performing independent oval holding tank assessments, fish were diverted at the mouth of the Pescalator[®] and transferred into a rectangular 1500-l tank with an internal crowder. Each of these components was studied for a several-week period, due to the required reconfiguration of the experimental system.

Experiment 2: Cylindrical collecting/holding tank with lift bucket

Plasma data were evaluated in 2006 for each experimental group (control fish, standardized stress fish, and treatment fish from the cylindrical holding tank and lift bucket under different holding durations within the tanks: 4 h, 8 h, 12 h, and for the lift bucket independently). After the 2005 experiments, we determined that there were no significant differences among durations so we focused on increasing our sample size by reducing the number of durations and doing more replicates within each of those durations to attempt to detect a difference. Tank flows ($0.226 \text{ m}^3/\text{s}$) and stage heights were set and fish were inserted into it by gently submerging the 87-l tank and allowing the fish to swim out. This experiment was divided into two parts, reflecting relevant components: the cylindrical holding tank and lift bucket together, and the lift bucket alone (Fig. 5). Independent cylindrical holding tank assessments could not be made without inflicting significant capture and handling stress, precluding such data from our study. For cylindrical holding tank and lift bucket assessments, fish were removed from the cylindrical holding tank into the lift bucket. Fish were collected and sampled after they were held in the cylindrical holding tank for a randomly selected duration (i.e., random draw). These fish then were released into the rectangular 1500-l tank with an internal crowder that was positioned under the lift bucket on a trolley system to pull fish out from under the tank for fish sampling. To assess the lift bucket independently from the tank, fish were inserted directly into the 1890-l lift bucket by submerging the 87-l tank of fish. Fish then were released from the lift bucket into the rectangular, 1500-l tank. Due to a tank wall failure, the cylindrical holding tank/lift bucket and lift bucket experiments were conducted during separate times of the year.

Sampling

Fish were captured and removed from respective 1500-l tanks with modified 10-cm x 18-cm dip nets with a 1.5-l plastic reservoir sewn into the cod-end, so that fish could be transferred in water to minimize stress. All transfers of fish were accomplished quickly (<30 s) with minimal disturbance and handling trauma to the fish. Control fishes were sampled from previously undisturbed 87-l tanks. Standardized stress fish were held in a conventional 10-cm x 18-cm dip net for 30 s before sampling. This standardized stress treatment has been used in many past studies on Chinook salmon and other species, making it a useful standard for comparing stress responses among species (Barton et al. 1980, Barton et al. 1986, Haney et al. 1992, Barton 2000, Barton et al. 2000).

Two juvenile salmon were simultaneously captured from each treatment and quickly transferred to a bath containing a lethal dose of tricaine methanesulfate (MS-222, Argent Chemical Laboratories, Inc., Redmond, Washington; 200 mg/l), which immobilized them in less than 30 s. This anesthetic dose inhibits stress-related increases in plasma cortisol concentration in salmon (Strange and Schreck 1978, Barton et al. 1986, Barton 2000). Blood was collected for no more than 2 minutes after capturing the fish to ensure that detectable cortisol levels were not an artifact of the sampling techniques (Barton 2002). The fish were quickly wrapped in a Kimwipe[®] for ease of handling and to absorb residual water on the fish. The caudal peduncle was immediately severed with a scalpel, and blood was collected from the caudal vein and artery with 40- μ l, heparinized microhematocrit capillary tubes. Blood was immediately centrifuged using a microhematocrit centrifuge (Clay-Adams Autocrit Ultra3) for 4 min at 12,000 x *g* to

separate the plasma from the packed cells (Becton Dickinson Diagnostics, Sparks, Maryland). Hematocrit (packed cell volume) was measured shortly after collection. A triangular file was used to score the microhematocrit capillary tubes where they could be broken to isolate plasma from blood cells. Plasma obtained with from each fish was transferred into plastic cryogenic freezing vials and temporarily stored in a 10-l liquid-nitrogen dewar flask (-196°C). These samples were then transferred to a -80°C freezer for storage and later analyses of plasma cortisol, lactate, glucose, osmolality, chloride, sodium, and potassium. Weights (± 0.01 g) and measurements (TL, ± 1 mm) of each fish using an electronic balance and fish measuring board were recorded.

Plasma was later thawed for plasma cortisol, lactate, glucose, osmolality, chloride, sodium, and potassium measurements. Plasma cortisol concentrations were measured using a modified enzyme immunoassay (ELISA; Munro and Stabenfeldt 1984, Munro and Stabenfeldt 1985, Barry et al. 1993). Rabbit antiserum is prepared against cortisol-3-carboxymethyloxime:bovine serum albumin in phosphate buffer and the enzyme conjugate cortisol-3-carboxymethyloxime:horseradish peroxidase. The protein fraction of 25 μ l of plasma was precipitated by the addition of 500 μ l absolute ethanol. Samples were vortexed and centrifuged, and 50 μ l aliquots were then air dried. Before assay, the dried extract was reconstituted in 250 μ l diluted enzyme conjugate, cortisol-3-carboxymethyloxime:horseradish peroxidase was added and 50- μ l aliquots of each sample were taken in duplicate for the assay. The immunoassay sensitivity was 0.30 ± 0.046 pg/well. Intraassay variation ranged from 4.1 to 10.5% and interassay variation from 7.1 to 13.5%. This antiserum was specific for cortisol, with all steroids and steroid metabolites structurally related to cortisol showing less than 0.1% cross-reactivity.

Steroids and compounds showing greater than 0.1% cortisol cross-reactivity were prednisolone (9.9%), prednisone (6.3%), cortisone (5.0%), and Compound S (6.2%). Plasma lactate and glucose were measured with a polarographic analyzer (YSI 2700 Select, Yellow Springs Incorporated, Yellow Springs, Ohio). Osmolality was determined with a vapor pressure osmometer (Vapro 5520, Wescor Incorporated, Logan, Utah). Plasma chloride was measured using a coulometric titrator (Labconco digital chloridometer 4425000, Kansas City, Missouri). Plasma sodium and potassium concentrations were measured with a flame photometer (IL-343, Instrumentation Laboratories Incorporated, Lexington, Massachusetts).

All procedures described above were approved by the University of California, Davis, Animal Care and Use Committee (IACUC Animal Protocol #10879). Applicable State and Federal permits were obtained to conduct research with Chinook salmon in California (Endangered Species Act Research Permit #1027, Endangered Species Act Section 10 Permit, California Scientific Collecting Permit #801159-05) and Colorado (State of Colorado Fish Importation Permit # 04IMPT154).

Data Analyses

Statistical analyses were performed using SAS 9.1 (SAS Institute Inc., Cary, North Carolina) and Sigmastat 3.0 (Jandel Scientific, San Rafael, California) software packages. Differences between treatments and controls were tested using an unbalanced 3x5 (3x3 for cylindrical holding tank data) factorial design; control, standardized stress, and holding tank in 5 (3 for cylindrical holding tank data) fixed durations (hours). The experiment was organized as a random complete block design (RCBD) analysis of

variance (ANOVA) with each group of the 5 (3) durations constituting a block, blocks nested within hours with hours fixed (Steel et al. 1997). Plasma constituent data were analyzed either by using RCBD factorial analysis of variance, one-way analysis of variance, or two-way analysis of variance with durations as a factor (Zar 1984, Steel et al. 1997). The Tukey's test was used for all pair-wise multiple comparisons for parametric data. The Shapiro-Wilk's test for normality and the Levene's test for homogeneity of variances were used to determine ANOVA assumptions. Data that did not meet the ANOVA assumptions and were unable to be power or log transformed were compared with a Kruskal-Wallis non-parametric analysis of variance on ranks with the Dunn's test for pairwise multiple comparisons (Zar 1984, Steel et al. 1997). Differences were considered significant at $P < 0.05$.

2.3 Results

Cortisol Responses

Experiment 1: Oval collecting/holding tank and Pescalator[®] Archimedes-type lift

There were no significant plasma cortisol differences among the durations that fish were held (i.e., 4, 6, 8, 12, or 24 h; $P = 0.513$) in any experimental treatments. Consequently, results across durations were pooled, within treatments, for subsequent analyses comparing treatments. Plasma cortisol concentrations increased stepwise in juvenile Chinook salmon from the oval holding tank to those exposed to the oval holding tank and Pescalator[®] to those exposed to the Pescalator[®] screw lift alone (Fig. 7; $P < 0.001$; $n = 152, 100, \text{ and } 50$ respectively). Cortisol levels in fish inserted into the oval holding tank alone were statistically indistinguishable from those in the control fish ($P =$

0.118), whereas fish inserted into the Pescalator[®] screw lift elicited the significantly highest cortisol values ($P < 0.01$), which were indistinguishable from those exposed to the standardized stress. Fish exposed to the entire process of a resident duration in the holding tank and subsequent removal via the Pescalator[®] showed intermediate cortisol levels to those in the oval holding tank and Pescalator[®] fish, but were significantly higher than those in the corresponding standardized stress and control fish, which were indistinguishable from each other (Fig. 7). Besides this comparison, control fish had the lowest levels of cortisol, and standardized stress treatments resulted in significant increases compared to those of controls ($P < 0.01$). All values (i.e., control, standardized stress, Pescalator[®]) for the Pescalator[®] experiments were significantly higher than for the other two groups ($P < 0.05$).

Experiment 2: Cylindrical collecting/holding tank with lift bucket

There were no significant plasma cortisol differences ($P = 0.612$) across the holding durations (i.e., 4, 8, or 12 h), and the treatment-specific results were pooled, within treatments. Plasma cortisol levels were significantly elevated, by greater than three-fold, in those fish tested through the lift bucket release, alone, compared to those in fish exposed to the cylindrical holding tank coupled with the lift bucket (Fig. 8; $P < 0.001$; $n = 48$ and 164 respectively). Interestingly, fish inserted into the cylindrical tank and removed via the lift bucket had significantly lower plasma cortisol levels than those in both control and standardized stress fish groups ($P < 0.01$). Whereas, salmon in the standardized stress treatment have a significant elevated response compared to those of

control fish ($P < 0.01$), the fish in the lift bucket were responding to a more severe acute stressor (i.e., lift bucket).

Experiment 1 vs. Experiment 2: Comparing holding tanks and conveyance methods

The 2005 oval holding tank and Pescalator[®] experiments resulted in salmon with significantly higher plasma cortisol levels compared to those exposed to comparable treatments in 2006 with the cylindrical holding tank and lift bucket (Figs. 7 & 8; $P < 0.001$). The Pescalator[®] resulted in the highest cortisol response, which was significantly greater than that in fish exposed to the lift bucket fish conveyance method ($P < 0.001$).

Glucose Responses

Experiment 1: Oval collecting/holding tank and Pescalator[®] Archimedes-type lift

Because there were no statistically significant differences in juvenile Chinook salmon plasma glucose concentrations, within treatment groups, among the 4, 6, 8, 12, or 24 h durations ($P = 0.586$), treatment-specific data were pooled, within treatments, across all of the durations. Oval holding tank fish showed no difference in plasma glucose levels compared to control and standardized stress groups (Fig. 9; $P = 0.095$). However, the combined oval holding tank with Pescalator[®] showed significantly elevated plasma glucose concentrations (Fig. 9; $P < 0.001$). Pescalator[®] treatments had the highest plasma glucose response, which was statistically indistinguishable from the significantly elevated standardized stress glucose response for the same set of experiments ($P = 0.007$).

Experiment 2: Cylindrical collecting/holding tank with lift bucket

Because there were no significant, treatment-specific differences for plasma glucose concentrations among experiment durations (i.e., 4, 8, or 12 h; $P = 0.256$), treatment-specific data were pooled, within treatments, across all durations. Plasma glucose levels were significantly lower in the combined cylindrical holding tank and lift bucket experiments' fish, compared to those in the control and standardized stress treatment groups (Fig. 10; $P < 0.001$), which were statistically similar ($P = 0.812$). Standardized stress treatments did not elicit a glucose response after the 30-s air immersion. Plasma glucose concentrations among treatment groups in lift bucket experiments were statistically indistinguishable (Fig. 10; $P = 0.449$).

Experiment 1 vs. Experiment 2: Comparing holding tanks and conveyance methods

Juvenile Chinook salmon plasma glucose levels in the 2005 oval holding tank and Pescalator[®] experiments were significantly higher than those in the 2006 cylindrical holding tank and lift bucket experiments' fish (Figs. 9 & 10; $P < 0.001$). Pescalator[®] treatments' fish plasma glucose levels were nearly double those in the lift buckets' fish, with means of 0.984 g/l and 0.552 g/l respectively ($P < 0.001$).

Lactate Responses

Experiment 1: Oval collecting/holding tank and Pescalator[®] Archimedes-type lift

Because there were no significant, treatment-specific differences among the experimental durations that fish were held in the oval holding tank (i.e., 4, 6, 8, 12, or 24 h; $P = 0.437$), treatment-specific, plasma lactate data were pooled, within treatments,

across all durations. Whereas plasma lactate concentrations were statistically indistinguishable for the control versus standardized stress comparisons (Fig. 11; $P > 0.05$), they increased in all three treatment groups (i.e., oval holding tank, oval holding tank and Pescalator[®], Pescalator[®]; $P < 0.001$). The inclusion of the Pescalator[®] caused a significant elevation in lactate compared to that of the oval tank alone ($P < 0.001$), where the Pescalator[®], and oval holding tank and Pescalator[®] had similar increases in lactate levels ($P = 0.257$).

Experiment 2: Cylindrical collecting/holding tank with lift bucket

Because there were no treatment-specific differences ($P = 0.646$) among the 3 durations tested (i.e., 4, 8, or 12 h), treatment-specific plasma lactate data were pooled, within treatments, for subsequent analyses. Fish that had been inserted into the lift bucket alone and released had elevated plasma lactate levels (Fig. 12; $P < 0.025$). There was a slight, but significant decrease in plasma lactate for fish that were in the cylindrical holding tank and bucket combination ($P = 0.023$).

Experiment 1 vs. Experiment 2: Comparing holding tanks and conveyance methods

Pescalator[®] fishs' plasma lactate concentrations were almost double those of fish in the lift bucket, with means of 0.372 and 0.665 g/l respectively (Figs. 11 & 12; $P < 0.001$). This same pattern was shown in 2006 cylindrical holding tank and lift bucket experiments, with respective means of 0.654 and 0.336 g/l ($P < 0.001$).

Hematocrit Responses

Experiment 1: Oval collecting/holding tank and Pescalator[®] Archimedes-type lift

Juvenile Chinook salmon hematocrit levels were statistically indistinguishable among control, standardized stress, and experimental treatments in all 3 experiments (Fig. 13; $P > 0.100$) and among all holding durations (i.e., 4, 6, 8, 12, or 24 h; $P = 0.417$). The mean overall hematocrit level for 2005 was 35%.

Experiment 2: Cylindrical collecting/holding tank with lift bucket

Because there were no statistical differences among the holding durations (i.e., 4, 8, or 12 h; $P = 0.296$), treatment-specific hematocrit data were pooled, within treatments, across all durations. Standardized stress fish showed a slight, but statistically significant rise in hematocrit (Fig. 14; $P < 0.05$), but no other significant differences were found. The average overall hematocrit level for the cylindrical holding tank and lift bucket experiments in 2006 was 34%.

Experiment 1 vs. Experiment 2: Comparing holding tanks and conveyance methods

Hematocrit levels from the 2005 oval holding tank and the Pescalator[®] groups were elevated compared to the 2006 cylindrical holding tank and lift bucket, 35 and 33% respectively (Figs. 13 & 14; $P < 0.001$). In contrast, there was no detectable statistical difference between the Pescalator[®] and lift bucket conveyance methods' hematocrits ($P = 0.145$).

Osmolality Responses

Experiment 1: Oval collecting/holding tank and Pescalator[®] Archimedes-type lift

Because there were no significant, treatment-specific differences in juvenile Chinook salmon osmolalities among experimental durations (i.e., 4, 6, 8, or 12, 24 h; $P=0.648$), treatment-specific data were pooled, within treatments,. Oval holding tank and oval holding tank with Pescalator[®] experiments' fish yielded higher osmolality levels than control and standardized stress (Fig. 15; $P<0.001$). Although, there were no statistical differences in plasma osmolalities for all other 2005 experiments, including Pescalator[®] analyses, there was an increasing trend in experimental treatment groups (i.e., oval holding tank, oval holding tank with Pescalator[®], and Pescalator[®]).

Experiment 2: Cylindrical collecting/holding tank with lift bucket

There were no significant osmolality differences among experimental durations (i.e., 4, 8, or 12 h; $P=0.745$); among control, standardized stress, and cylindrical holding tank and lift bucket treatments (Fig. 16; $P=0.098$); or between the bucket test and the 3 tested groups ($P=0.593$).

Experiment 1 vs. Experiment 2: Comparing holding tanks and conveyance methods

The 2005 oval holding tank and Pescalator[®] osmolalities were significantly higher than those of the 2006 cylindrical holding tank and lift bucket experiments: 307.2 and 300.5 mOsm/kg, respectively (Figs. 15 & 16; $P=0.002$). Furthermore, Pescalator[®] treatments were much higher with respect to osmolality than that of lift buckets: 325.9 and 278.3 mOsm/kg, respectively ($P<0.001$).

Hydromineral Responses

Experiment 1: Oval collecting/holding tank and Pescalator[®] Archimedes-type lift

There were no significant differences in juvenile Chinook salmon hydromineral concentrations among durations (i.e., 4, 6, 8, 12, or 24 h; $P > 0.05$), so treatment-specific data were pooled within treatments. Among the hydrominerals (chloride, sodium, and potassium), only potassium levels in the oval holding tank fish yielded a significant difference, being lower than the control and standardized stress salmon's levels (Table 1; $P < 0.001$). The other potassium levels and all chloride and sodium concentrations were not significantly different among the treatments ($P > 0.05$).

Experiment 2: Cylindrical collecting/holding tank with lift bucket

There were no differences in juvenile Chinook salmon chloride, sodium, and potassium concentrations found among holding durations tested (i.e., 4, 8, or 12 h; $P > 0.05$) or among control, standardized stress, and experimental treatments in all 3 experiments (Table 1; $P > 0.05$).

Experiment 1 vs. Experiment 2: Comparing holding tanks and conveyance methods

Juvenile Chinook salmon plasma chloride concentrations were not significantly different for the 2005 oval holding tank and Pescalator[®] combination and the 2006 cylindrical holding tank and lift bucket (Table 1; 117.8 and 115.5 respectively; $P = 0.455$). However, salmon plasma chloride concentrations were higher for the Pescalator[®] when compared to the lift bucket, 117.0 and 109.7 meq/l respectively ($P = 0.002$).

Juvenile Chinook salmon plasma sodium levels were also higher in the 2005 oval holding tank and Pescalator[®] combination compared to the 2006 cylindrical holding tank and lift bucket (Table 1; 148.4 and 140.8 meq/l respectively; $P < 0.001$). There was also a statistically significant sodium difference between the Pescalator[®] (152.8 meq/l) and the lift bucket (140.2 meq/l; $P < 0.001$).

Consistent with the other hydrominerals, the mean salmon plasma potassium concentration was higher in the 2005 oval holding tank and Pescalator[®] combination, compared to the 2006 cylindrical holding tank and lift bucket (Table 1; 4.9 and 4.3 meq/l respectively; $P < 0.001$). Lastly, the Pescalator[®] mean fish potassium level was higher than the lift bucket fish's potassium level (6.0 and 4.4 meq/l respectively; $P < 0.001$).

2.4 Discussion

Current water export, fish screening, and salvage practices include handling, holding, confinement, and transport, which is presumably stressful to affected fishes. Because these practices may impact fish health and mortality, they may influence fish populations. Measurements of primary and secondary stress responses have been used by many researchers as quantitative indicators of traumatic or harmful effects on fish, and >95% of published articles pertain to salmonids (Barton and Iwama 1991, Lowe and Wells 1996). Many studies include plasma cortisol to assess a fish's sensitivity to a stressor because it is relatively simple to determine, and it mediates many other physiological functions (i.e., secondary stress responses). Although, the degree of cortisol response is directly related to severity and duration of the stressor (Barton et al.

1985a, Barton 2002), single measurements of plasma cortisol are merely instantaneous snapshots of a much larger dynamic process over time.

Cortisol Responses

Our juvenile Chinook salmon's cortisol levels were most often lowest in control groups and followed a 'classic' cortisol response during the standardized stress (Barton et al. 1980, Barton and Schreck 1987, Barton and Iwama 1991). Using this plasma indicator, our holding tank removal methods (i.e., Pescalator[®] and lift bucket) were the most stressful components of the process, and the Pescalator[®] screw lift resulted in the highest plasma cortisol levels. Tank alone effects were either the least stressful or were statistically equivalent to the control. Therefore, constant swimming at non-stressful velocities was associated with minimal cortisol responses. Salmonids swimming at low, sustained velocities following exhaustive exercise have lower plasma cortisol levels than those in still water, and have a swimming-facilitated recovery from stress (Boesgaard et al. 1993, Milligan et al. 2000, Farrell et al. 2001a). Rainbow trout (*O. mykiss*) placed in flowing water (i.e., 0.9 BL/s) post-exhaustive exercise can recovery completely in 2 h, a three-fold faster recovery, and show no further increase in plasma cortisol concentrations (Milligan et al. 2000). Additionally, fish swimming in the collecting/holding tanks may have a faster clearance rate of plasma cortisol due to increased perfusion rates in white muscle to meet metabolic demands (Young and Cech 1993). In addition, holding tank fish were swimming in a larger volume of water compared to that of the 87-L tanks to which they had been acclimating for 3 days prior, with a possible decrease in confinement stress. However, there were no statistical differences in plasma cortisol

among the durations that fish were held in the tank. If the shortest duration (i.e., 4 hr) had elevated plasma cortisol levels comparable to those of longer durations we might expect the initial high cortisol concentrations to be an artifact of insertion or acclimating-associated confinement stress. Often, there is a significant plasma cortisol increase following handling stress which remains elevated after 4 h post-handling for salmonids (i.e., Chinook salmon, Weber et al. 2002, Barton et al. 1986, Sharpe et al. 1998; brown trout (*Salmo trutta*), Pickering et al. 1982). This was not true of our experiments and there were no differences among holding durations and no apparent biological trends in the reduction of plasma cortisol levels over time.

Holding durations might be valuable in allowing fish to recover from a prior stressor to reduce subsequent stress. If cortisol and the resulting secondary effects in stressed fish are promptly reduced to basal or pre-stress levels, the effects of stress as a result could be curtailed and survival improved. In 2005, we found a clear, step-wise increase in plasma cortisol from the oval holding tank with the lowest plasma cortisol concentrations to the combined oval holding tank and Pescalator[®], and highest with the Pescalator[®]. Those fish that were allowed a holding duration before removal with the Pescalator[®] showed lower plasma cortisol concentration than those that were only transferred with Pescalator[®]. Unfortunately, we could not isolate the cylindrical tank in the same manner as the oval holding tank and we could not determine a cylindrical holding tank effects without contributing additional handling stress that potentially would mask holding-related stresses.

Our data suggest that the Pescalator[®] is the most stressful component of the collecting-holding-conveyance systems tested. However, we found consistently elevated

cortisol levels in the control and standardized stress groups, as well as in the Pescalator[®] fish, for this set of experiments. We attribute these higher values to the seasonal timing of the experiments when the Pescalator[®] was tested. Pescalator[®] experiments were held in July and August of 2005, and it was observed that these fish were undergoing the parr-smolt transformation (smoltification). There was a loss of parr markings, and the fish had become silver in appearance, consistent with this transformation. Salmonids have unique corticosteroid profiles during normal anadromous behavior (Lowe and Wells 1996), where resting cortisol levels can increase ten-fold during smoltification (Barton et al. 1985a, Young et al. 1989, Barton and Iwama 1991). Atlantic salmon smolts were more responsive to acute handling stresses and confinement stress than parr (Carey and McCormick 1998). Coho salmon are also more sensitive during changes in cortisol levels and have increased cortisol titers during smoltification (Maule et al. 1993). Unfortunately, difficulties in altering holding tank configurations to segregate tank components precluded randomization of the Pescalator[®] experiments throughout the study period. Comparisons between years must be made cautiously because of the different cohorts of juvenile Chinook salmon and the experience level of the project personnel. Although, a side-by-side comparison would be optimal to compare the effects of different components on cortisol production, the inclusion of the control and standardized stress groups in both years helped to resolve stress-related differences in tank design and conveyance methods.

Glucose Responses

Stress is metabolically challenging for fish and plasma glucose increases (i.e., as fuel) are commonly measured as secondary stress responses. Rapid increases (i.e., minutes) in plasma glucose are probably mediated by catecholamines rather than cortisol (Mazeaud et al. 1977, Mazeaud and Mazeaud 1981). Hyperglycemia is a result of glycogenolysis stimulation from catecholamines associated with increased energy demands for a “flight or fight” response (Mazeaud and Mazeaud 1981). However, cortisol is essential to long-term maintenance of hyperglycemia after catecholamine effects have subsided (Barton and Iwama 1991, Mommsen et al. 1999). Notably, glucose (and cortisol) concentrations were lowest in cylindrical holding tank combined with the lift bucket juvenile salmon, in our studies. One explanation for this observation is that less plasma cortisol was available to stimulate glycogenolysis. Another explanation for the lower levels of plasma glucose compared to those in the control and standardized stressor fish concerns their constant swimming, during holding durations, which may have depleted fuel in the blood.

Control and standardized stress fish showed no increase in plasma glucose because they are sampled too quickly to produce glucose fluctuations that might be seen in the plasma. Lift Bucket experiments took less than 5 minutes for completion and presumably this short interval contributed to the lack of statistical differences between control, standardized stress, and lift bucket treatment. The exception was the Pescalator[®] fish because of increased smoltification-associated cortisol concentrations. The hyperglycemia found in oval holding tank with Pescalator[®] and independent Pescalator[®] experiments may have resulted from the time required to remove the fish (≥ 10 minutes)

and the high plasma cortisol levels. Because the oval holding tank experiments without the Pescalator[®] had glucose values that were statistically indistinguishable from the control, the hyperglycemia can be attributed to the disturbance due to the Pescalator[®] screw lift removal method. The Pescalator[®] appears to be the most stressful component of the process, despite seasonal, smoltification-related hormone cycles.

Lactate Responses

Stress-induced elevations in plasma corticosteroids and glucose are often accompanied by increases in blood lactate, if heightened muscular activity from swimming is involved (Driedzic and Hochachka 1978). Previous studies have shown that plasma lactate increases following handling stress (Pickering et al. 1982, Young and Cech 1993). Our 30-second standardized stress was too rapid to observe a rise in plasma lactate. However, our salmon's plasma lactate levels for the Pescalator[®] were nearly double that of the lift bucket. These clear differences are most likely the result of Pescalator[®]-avoidance behavior while the tank is draining. Juvenile Chinook in this study were observed burst swimming and avoiding the mouth of the Pescalator[®] until they were fatigued, possibly. Struggling and increased swimming behavior occurred with both removal methods, although the Pescalator[®] fish showed much higher plasma lactate levels. Exercise leading to exhaustion involves short stints of vigorous swimming driven by white muscle fibers under an anaerobic state (Milligan 1996). Swimming performance may be limited during its recovery (Milligan and McDonald 1988, Milligan 1996). Plasma lactate concentration typically peaks 2-4 hours after vigorous exercise or exhaustive stress and may take 12-24 hours to completely recover (Wood and Perry 1985,

Milligan and McDonald 1988). Elevated cortisol levels also exert a negative influence on lactate utilization and glycogen recovery metabolism. It is thought that the inhibition occurs from regulation of muscle glycogenolysis, but the mechanisms for this negative relationship are not understood in fish (Milligan 1996). Notably, lower cortisol levels in the cylindrical holding tank with bucket reflect significantly lower plasma lactate. It is not well understood in fish whether the lower plasma lactate levels result from increased clearance of lactate from the blood by aerobic, red muscle or enhanced lactate metabolism in white muscle (Milligan 1996). Because up to 90% of the lactate produced in white muscle during strenuous exercise could be retained, muscle lactate concentrations may represent a better index of stress-associated exhaustive activity than plasma lactate.

Hematocrit Responses

Hematocrit levels can increase under stressful conditions from erythrocytic swelling (Soivio and Nikinmaa 1981, Wood and Perry 1985, Jensen 1991) or from splenic contractions that increase the number of erythrocytes in the circulating blood (Yamamoto 1987). Whereas erythrocytic swelling results from the trans-membrane ion exchange and consequent water uptake, protecting intracellular pH during extracellular acidosis (Nikinmaa 1986), splenic contractions typically increase blood oxygen carrying capacity, via total hemoglobin increases. Contraction of the spleen is known to occur under strenuous exercise, hypercapnia, or hypoxia (Yamamoto 1987, Yamamoto 1988, Perry and Kinkead 1989). With one exception there were no differences among hematocrit levels in any of our experiments, and all hematocrits reflected normal, healthy

levels for salmonids (Wedemeyer et al. 1990, Barton and Iwama 1991, Randall and Wright 1995, Martinelli et al. 1998). The one, of 15, statistically elevated hematocrit mean differed from the others by only 1%, possibly due to erythrocytic swelling, splenic contractions, or chance (natural variability). Because plasma lactate, which is usually associated with burst-swimming-induced glycolysis in normoxic fish, was not elevated in the experimental treatment with the increased hematocrit, this result was probably due to chance.

Osmolality and Hydromineral Responses

Osmolality is the total number of osmotically active particles in a solution, summing the solutes present. The major solutes that typically affect plasma osmolality are: sodium, potassium, chloride, bicarbonate, and glucose. Osmolality can be affected, especially via water shifts, by acute stress in fishes (Love 1970, Mazeaud et al. 1977, Wells et al. 1986). Low plasma chloride (90 meq/l) and osmolality concentrations < 200 mOsm/kg in salmonids indicate compromised osmoregulatory systems (Wedemeyer 1996, Barton et al. 2002). We measured small but significant juvenile salmon osmolality increases in the oval holding tank and oval holding tank with Pescalator[®] experiments. Plasma hydromineral concentrations did not change in any of experiments except for potassium in the oval holding tank experiments. Importantly, there was no hemodilution in any of the experiments, indicating water shifts from the freshwater environment into the fish associated with osmoregulatory dysfunction (Mazeaud et al. 1977, Carmichael et al. 1984). Previous studies have shown that sodium decreases (Barton et al. 1985b), and plasma potassium increases (Carmichael et al. 1983) following handling stress. Because

none of the hydrominerals had significant increases they are not responsible for the observed increases in osmolality. Presumably water shifts from blood to muscle space, associated with putative muscle lactate increases, concentrated the plasma solutes sufficiently to increase osmolality. Although, plasma hydrominerals and osmolality may not be particularly sensitive stress indicators (e.g., compared to catecholamines and cortisol; Barton et al. 2002), our increased salmon plasma osmolality, sodium, and potassium levels for the oval holding tank with Pescalator[®] experiments suggest an osmotic imbalance caused by the more stressful effects of the this tank design with removal method compared to that of the cylindrical holding tank with lift bucket.

Conclusion

Assessing stress in fish by means of chemo-physiological measurements is a useful approach for biologists to determine the health of fishes and their populations and becoming more readily available and common to use (Wedemeyer et al. 1990, Iwama et al. 1997). However, caution is warranted when interpreting results because many of these measurements represent instantaneous indicators in a broader, dynamic process, with plasma constituents' changes reflecting normal responses to less extreme or prolonged stressors, from which a fish can quickly recover. Also, juvenile Chinook salmon exhibit considerable variation in their stress response, even when acclimated to the same environmental conditions and exposed to the same stressors (Barton 2000).

Prolonged elevation of plasma cortisol and sequentially triggered secondary and tertiary stress responses are main contributors to the detrimental effects of stress on survival (Barton and Iwama 1991, Pickering 1992). Schreck et al. (1989) found that an

extended plasma cortisol increase indicated a reduced relative fitness of stressed coho salmon and resulted in lower survival rates after hatchery coho were released. Predation has been noted as one of the most significant losses of salvaged fishes and juvenile Chinook salmon may experience low survival rates after exposure to the handling and transportation stress of these salvage facilities (Liston et al. 1994, OCAP Biological Opinion 2005, Kimmerer and Brown 2006).

We investigated the impacts of acute stressors on juvenile Chinook salmon during a fish salvage process. The goal was to determine whether certain aspects of collecting/holding tanks, transfer designs, and duration of holding physiologically affected juvenile Chinook salmon and their potential vulnerability to predation after release. It has been argued that the cylindrical collecting/holding tank with a lift bucket conveyance method, currently used to transfer fish from holding tank to transporting vehicle, significantly adds to acute physiological stresses and potential mortality (Raquel 1989, Liston et al. 2000, Karp and Lyons 2007). We hypothesized that stress exhibited in held fish is affected by tank design and removal method; fish collected in the cylindrical holding tank with lift bucket will significantly alter plasma constituent levels compared to those of control fish and those collected in an oval holding tank with the Pescalator[®] screw lift. We determined that an increased stress response occurs more often and is more pronounced during the conveyance processes, whether it is the Pescalator[®] or lift bucket method. We suggest that an oval holding tank with a lift bucket would be the least stressful combination to collect, hold, and transfer fish. The oval holding tank was equipped with traveling screens, removing vegetative debris and refuse (not investigated in this study), which would decrease collisions with this material in the tank and

abrasions during the dewatering and transfer process. Overall we found no differences among holding durations in either type of holding tank design. Therefore we reject our assumption that stress in held fish is affected by the duration detained. Fish collected and detained for extended periods of time (4-24 h) did not show significant differences in plasma constituents. Importantly, holding durations (of at least 4 h) might allow fish to recover from a prior stressor to reduce subsequent stress from the removal process and transference to the fish hauling truck via the Pescalator[®] screw lift or lift bucket.

Results of this research should assist in modernizing fish salvage facilities in the Sacramento-San Joaquin Delta and elsewhere. Future studies should link these chemophysiological to organismal and ecological level-responses over a functional continuum to accurately assess these changes in identifying the most stressful points in the salvage process. Modifications of stressful salvage practices should decrease the detrimental effects of entrainment and holding, leading to a reduction in the incidental take of fishes and a reduction of indirect mortality from sublethal stressors. The wide use of these results and the implementation of results from additional studies (e.g., effects of debris removal) should minimize fish losses associated with water diversion-related fish salvage operations.

Chapter 3

Effects of handling and holding environment on swimming
performance and kinematics of juvenile Chinook salmon
(*Oncorhynchus tshawytscha*)

3.1 Introduction

Stress affects various physiological conditions and may have significant effects on swimming performance of fishes (Barton et al. 2002). Physiological studies have shown that exposure to physical, chemical, or perceived stressors causes changes in plasma hormone and constituent levels that can alter blood and tissues (Chapter 2, Wendelaar Bonga 1997, Barton et al. 2002). Changes in the chemo-physiological and contractile properties of muscle are probably due to the stress response that affects swimming and thus compromises predator avoidance (Sigismondi and Weber 1988, Mesa et al. 1994). Knowing how stress affects responses to stimuli and swimming performance is important, because swimming involves the integration of numerous physiological processes, estimation of swimming ability can provide a sensitive index to the overall “health” and stress of fish (Wedemeyer et al. 1990). Challenge tests offer an approach to determine and evaluate the sublethal effects of stress at the organismal level (Wedemeyer and McLeay 1981). The ability of a fish to swim under various treatments (potentially stressful conditions) can be compared to that of control fish (unstressed) and standardized stressed fish (known stressor). However, a reduction in swimming stamina after exposure to a stress factor can be difficult to determine biologically (Horak 1972).

There is a growing body of literature on mechanisms of fast-start swimming behavior and startle responses of fish and amphibians, much of which has been performed on larval fishes (Hunter 1972, Webb and Corolla 1981, Taylor and McPhail 1985a, Taylor and McPhail 1985b, Wardle and He 1987, Domenici and Blake 1997, Garenc et al. 1998, Wilson and Franklin 1999). However, little is known about the effects of stress on burst swimming speeds and startle responses (Fuiman 1986, Yin and

Blaxter 1987, Sigismondi and Weber 1988, Batty and Blaxter 1992). Information from swimming performance challenges can also be used also to aid in the design of fish passage, ladders, culverts, screens, diversions, and water intake structures (Berry and Pimentel 1985, Castro-Santos and Haro 2006). This information is particularly a problem where fish are exposed to large-scale diversions, such as the large pumping plants at the Tracy Fish Collection Facility and Skinner Delta Fish Protective Facility (Byron, California). The size and complexity of fish salvage facilities at these pumping plants makes them difficult to sample fishes for research purposes (Bates and Vinsonhaler 1955, Danley et al. 2002); however laboratory simulation experiments can provide much needed information to better understand the effects of these facilities on fishes.

Fish utilize high speeds and burst swimming to capture food and evade predation, while routine, steady swimming is primarily employed for foraging and migrating (Hunter 1972, Fuiman 1986). Burst or fast-start swimming movements involve a rapid spurt of high-acceleration muscle activity from either at rest or from a steady swimming state (Weihs 1973, Jayne and Lauder 1993, Wakeling 2006). There are three kinematic stages in burst swimming behavior in fishes (Weihs 1973, Webb 1978a, Taylor and McPhail 1985a, Jayne and Lauder 1993). First, the preparation stage (stage one) where the fish bends into a “C” shape, induced by the simultaneous activity of muscle down one side of the body. Second, a propulsion stage (stage two) where there is a rapid undulation of the body and caudal fin to a position that is opposite of the preparation stage. And third, a gliding stage (stage 3) where the fish “leaps” forward with a straight body or with a normal swimming rhythm.

Body bending during swimming results from the interaction of muscular contractions and internal stiffness to the body (Wakeling 2006). Fast-start body flexes show greater curvatures than those typically observed during normal steady swimming. The maximum, stage one curvature varies along the length of the body among fishes to a maximum between 0.5-0.8 body lengths (L; Wakeling and Johnston 1998, Spierts and Van Leeuwen 1999, Wakeling 2006). The magnitude and duration of muscle activity dictate the amount of body bending associated with swimming (Wakeling 2006). Fast-starts with reduced muscular activity result in lower accelerations with body flexions that do not resemble a strong C-shape and tend to look more similar to the slower S-starts (Spierts and Van Leeuwen 1999). If a fish forms a strong C-shape, it will have more power and velocity as it “leaps” out than a fish that only flexes a small amount before swimming. Specifically, if a sublethal stress reduces the body bending and curvature of the C-shape, the startled prey fish may lack the propulsion needed to escape a predator attack.

Another index of swimming stamina, maximum swimming performance, can be measured by constantly chasing a subject to exhaustion. This method has been used for fish larvae (Heath et al. 1993a, Heath et al. 1993b, Heath et al. 1997) and amphibians (Watkins 2000), not on juvenile fishes. This method of measuring swimming performance is a logical companion to burst swimming experiments because it is simple and combines both burst and sustained swimming speeds (i.e., avoiding the prodding rod, Beamish 1978). This chasing protocol simulates persistent pursuit by a predator and serves as a good indication of maximum swimming performance (Heath et al. 1993a,

Heath et al. 1993b, Heath et al. 1997). Predator evasion may favor individuals with superior swimming performances (Webb 1982, Fuiman 1986).

The purpose of this study was to determine burst and maximum swimming performances of fish subjected to stressors associated with two, different fish-salvage strategies and to evaluate the importance of different types of swimming performance indices as indicators of stress and predator avoidance (Chapter 4). If stress reduces swimming performance in fishes, it could decrease their survival from predation during the salvage process and after release. To minimize the harmful effects of fish salvage, including direct and indirect mortality, it is necessary to quantify the stress associated with different components of the collection and holding process. Our focus was to assess whether the collecting/holding tanks, transfer designs, and duration of holding physiologically affect juvenile Chinook salmon's burst and maximum performance capability (ca. 100 mm TL; see Chapter 1). We hypothesized that the cylindrical collecting/holding tank with a lift bucket conveyance method, currently used to transfer fish from holding tank to transporting vehicle, would significantly reduce the burst and maximum swimming parameters of juvenile salmon compared to those of a pre-experiment (control) fish and those collected in an oval holding tank with the Pescalator[®] Archimedes lift. The Pescalator[®] Archimedes lift may transfer salvaged fish more carefully, without air exposure, to a fish hauling truck (Conte 2004) and oval holding tank design advancements, including traveling screens to remove debris and different velocities around the tank due to its near-elliptical shape. Furthermore, we hypothesized that juvenile Chinook salmon held for extended periods of time (i.e., >4 h, but ≤24 h) will show statistically indistinguishable swimming abilities.

3.2 Materials and Methods

Source and Care of Fish

Sacramento River Chinook salmon (*Oncorhynchus tshawytscha*) were obtained in 2005 and 2006 from the Coleman National Fish Hatchery (Anderson, California) and transported to the U.S. Bureau of Reclamation's Hydraulics Laboratory (Denver, Colorado). Juvenile fall-run Chinook salmon were considered surrogates for winter-run Chinook salmon, which are federally and state listed endangered species and not available in sufficient numbers for this experiment. Because of declining numbers fall-run Chinook are no less important and valuable to this study. Salmon were maintained in 757-l circular tanks equipped with an aerated, partial recirculating water system to deliver water continuously along with dechlorinated, air-equilibrated municipal water. Water temperatures were maintained at 18°C and flow direction was altered weekly for symmetrical muscular development while swimming into the gentle current. Fish were held under a natural photoperiod (38° N latitude) with natural and halogen light, and were fed BioOregon (BioOregon Inc., Longview, Washington) semi-moist pellets at 1.5-2% body weight per day.

Treatment and control groups of salmon were marked with implanted, white microspheres on caudal and anal fins with a high pressure needle (Photonic tagging; New West Technology, Arcata, California). Fish were tagged to differentiate treatments for a subsequent predation study (Chapter 4), and were allowed to recover for at least two weeks after marking before use in experiments. This method of fish marking was less

severe/invasive, compared with other techniques such as fin clipping or Floy tagging, and presumably did not affect the salmon's stress response (Hayes et al. 2000).

Groups of 20 fish (103 ± 7 mm, mean \pm standard deviation, TL in 2005 and 105 ± 6 mm TL in 2006) were transferred to 87-l circular, polyethylene tanks 3 days before an experiment to acclimate to Hydraulic Laboratory water conditions and be in close proximity to the experimental holding tanks where handling stress responses were evaluated. Fish carrying the same mark were held in one of four randomly selected 87-l tanks (i.e., 2 control groups, 1 standardized stress group, and 1 treatment group) under constant water flow at $19.5 \pm 1^\circ\text{C}$ throughout the duration of the study from February through August 2005 (Experiment 1) and April through August 2006 (Experiment 2). Fish were fed once daily in the staging area, except for 24 hours before experimental use.

Experiment 1: Oval collecting/holding tank and Pescalator[®] Archimedes-type lift

Swimming performance data were evaluated in 2005 for each experimental group (control fish, standardized stress fish, and treatment fish from the oval holding tank, oval holding tank and Pescalator[®] under different holding durations within the tanks: 4 h, 6 h, 8 h, 12 h, 24 h, and for the Pescalator[®] independently). The oval holding tank flows ($0.226 \text{ m}^3/\text{s}$) and weir heights were set, and fish were inserted into it by gently submerging the 87-l tank and allowing the fish to swim out. To separate stresses inherent in components of the collection/holding process, the experiment was divided into three major parts: the oval holding tank and Pescalator[®] together; the oval holding tank alone; and the Pescalator[®] alone (Fig. 3). Fish were collected and sampled after they were held in the oval holding tank for a randomly selected duration (i.e., random draw). For oval

holding tank and Pescalator[®] together assessments, fish were removed from the tank by the Pescalator[®] screw lift and conveyed into a 1500-l, cylindrical plastic tank with an internal crowder net making the fish readily accessible. While performing independent oval holding tank assessments, fish were diverted at the mouth of the Pescalator[®] and transferred into a rectangular 1500-l tank with an internal crowder. Each of these components was studied for a several-week period, due to the required reconfiguration of the experimental system.

Experiment 2: Cylindrical collecting/holding tank with lift bucket

Swimming performance data were evaluated in 2006 for each experimental group (control fish, standardized stress fish, and treatment fish from the cylindrical holding tank and lift bucket under different holding durations within the tanks: 4 h, 8 h, 12 h, and for the lift bucket independently). Sample sizes were increased for all treatment groups by reducing the number of durations, based on the results from 2005 experiments. Tank flows ($0.226 \text{ m}^3/\text{s}$) and stage heights were set and fish were inserted into it by gently submerging the 87-l tank and allowing the fish to swim out. This experiment was divided into two parts, reflecting relevant components: the cylindrical holding tank and lift bucket together, and the lift bucket alone (Fig. 5). Independent cylindrical holding tank assessments could not be made without inflicting significant capture and handling stress, precluding such data from our study. For cylindrical holding tank and lift bucket assessments, fish were removed from the cylindrical holding tank into the lift bucket. Fish were collected and sampled after they were held in the cylindrical holding tank for a randomly selected duration (i.e., random draw). These fish then were released into the

rectangular 1500-l tank with an internal crowder that was positioned under the lift bucket on a trolley system to pull fish out from under the tank for fish sampling. To assess the lift bucket independently from the tank, fish were inserted directly into the 1890-l lift bucket by submerging the 87-l tank of fish. Fish then were released from the lift bucket into the rectangular, 1500-l tank. Due to a tank wall failure, the cylindrical holding tank/lift bucket and lift bucket experiments were conducted during separate times of the year.

Sampling

Fish were captured and removed from respective 1500-l tanks with modified 10-cm x 18-cm dip nets with a 1.5-l plastic reservoir sewn into the cod-end, so that fish could be transferred in water to one of two swimming performance chambers, to minimize stress. All transfers of fish were accomplished quickly (<30 s) with minimal disturbance and handling trauma to the fish. Control fishes were sampled from previously undisturbed 87-l tanks. Standardized stress fish were held in a conventional 10-cm x 18-cm dip net for 30 s before sampling. This standardized stress treatment has been used in many past studies on Chinook salmon and other species, making it a useful standard for comparing stress responses among species (Barton et al. 1980, Barton et al. 1986, Haney et al. 1992, Barton 2000, Barton et al. 2000).

One juvenile salmon was captured from each treatment and quickly transferred to an acrylic raceway for measuring burst swimming performance (including mean velocity, maximum velocity, mean acceleration, maximum acceleration, and C-start angles) and another to a 1-m-diameter plastic tank configured as an annular “racetrack” for measuring

maximum swimming performance. The burst swimming raceway (220-cm length with a 30-cm wide swimming channel, Fig. 17) was filled to 25 cm depth to minimize vertical swimming. The raceway bottom was white with a black 1-cm x 1-cm grid to provide scale. The raceway sides were also covered with black polyethylene sheets to prevent outside disturbance. Startle responses and burst swimming speeds and were filmed with a Phantom v4.2 high-speed camera (Vision Research, Inc., Wayne, New Jersey) fitted with a wide angle lens and lighted by four, 150-W floodlights situated 1.3 m above the raceway. Lights were switched on before the filming sequence, and water temperature in the raceway did not change during filming. At each end of the raceway, the tank opened up to a 36-cm x 50-cm “corral” section. A fish from either the control, standardized stress, or treatment group was placed into the start “corral” and given 1 min to equilibrate and orient in a direction down the raceway while remaining in the camera field of view. The start “corral” had a gate to confine and orient the fish to one end of the raceway before the startle stimulus. The camera was positioned directly above the beginning of the raceway at the fish “corral” gate at a distance where the fish’s start and burst swim, but not the dropping ball, were in the field of view. The gate was lifted simultaneously as the fish was stimulated to swim with a tethered tennis ball that strikes the water directly behind the fish. The high-speed camera system, which is designed for motion analysis, recorded fish burst swimming motions as it swam to the opposite end of the raceway, at 500 frames/s at a 224 x 512 pixel resolution.

The high-speed video recordings were analyzed image-by-image (Peak Performance Technologies, Inc., Centennial, Colorado) to determine velocities and acceleration rates at specific distances, and fast-start body orientation (C-shape).

Maximum burst swimming velocity was determined as the greatest distance moved over a specified elapsed time (cm/s). Acceleration was calculated as increasing velocity up to maximum burst swimming speed (m/s^2). Cin video files from the high-speed camera were converted to avi files with Cinepak Codec (Radius, Inc., San Jose, California) using VideoMach version 3.3.4 software (www.gromada.com) and then imported into the Peak Motus 6.1 program (Peak Performance Technologies, Inc., Centennial, Colorado). The software automatically calibrates the pixels/cm with the filming information (resolution, recording speed) and the fish can then be tracked by two points on a centimeter grid. For determining C-start angles, we chose representative samples of C-starts closest to the mean velocity for the control and each treatment group. We used a video segment before the preparation stage, where the fish was mostly straight, to when it contracted and bent into a “C” shape to establish three points to measure contraction angles (Fig. 18). Angle theta (θ) was determined to be the angle made from the two intersecting lines meeting at the center of mass. Theta (θ) was recorded as the minimum angle when $<180^\circ$ and as the minimum elementary angle when $>180^\circ$. Using the equation

$$0.35 + (0.2TL),$$

where TL is the total length (mm) of a salmonid to determine the center of mass (Webb 1977, Webb 1978a), we manually tracked the trailing edge of the caudal fin, head, and center of mass points for each fish image-by-image. The tracking software then calculated fish acceleration, velocity, and angles between the three designated points.

To assess maximum swimming performance we configured an annular “racetrack” that featured a 60-cm-diameter steel pipe pedestal in the center of the 1-m-diameter plastic tank, providing a 20-cm-wide annular swimming “racetrack” between

the inner and outer walls. Four, equally spaced radiating lines were painted on the bottom of the tank, separating it into quadrants. The tank was filled to 25 cm depth to minimize vertical swimming. A fish was transferred via a modified 10-cm x 18-cm dip net with a 1.5-l plastic reservoir from the control tank or treatment group origin to the “racetrack” and given 1 min to equilibrate. The fish was then constantly chased with an acrylic prodding rod until it would no longer respond to caudal fin touches. We counted (10 min maximum duration) the number of lines it crossed until three consecutive touches provoked no response. A consistent chasing/prodding technique was used to decrease technique-associated variability.

After both types of swimming performance experiments, fish were anesthetized using 70 mg/l tricaine methanesulfate (MS-222, Argent Chemical Laboratories, Inc., Redmond, Washington), and weights (± 0.01 g) and measurements (TL, ± 1 mm) of each fish using an electronic balance and fish measuring board were recorded.

All procedures described above were approved by the University of California, Davis, Animal Care and Use Committee (IACUC Animal Protocol #10879). Applicable State and Federal permits were obtained to conduct research with Chinook salmon in California (Endangered Species Act Research Permit #1027, Endangered Species Act Section 10 Permit, California Scientific Collecting Permit #801159-05) and Colorado (State of Colorado Fish Importation Permit # 04IMPT154).

Data Analyses

Statistical analyses were performed using SAS 9.1 (SAS Institute Inc., Cary, North Carolina) and Sigmastat 3.0 (Jandel Scientific, San Rafael, California) software

packages. Differences between treatments and controls were tested using an unbalanced 3x5 (3x3 for cylindrical holding tank data) factorial design; control, standardized stress, and holding tank in 5 (3 for cylindrical holding tank data) fixed durations (hours). The experiment was organized as a random complete block design (RCBD) analysis of variance (ANOVA) with each group of the 5 (3) durations constituting a block, blocks nested within hours with hours fixed (Steel et al. 1997). Swimming performance data were analyzed either by using RCBD factorial analysis of variance, one-way analysis of variance, or two-way analysis of variance with durations as a factor (Zar 1984, Steel et al. 1997). The Tukey's test was used for all pair-wise multiple comparisons for parametric data. The Shapiro-Wilk's test for normality and the Levene's test for homogeneity of variances were used to determine ANOVA assumptions. Data that did not meet the ANOVA assumptions were compared with a Kruskal-Wallis non-parametric analysis of variance on ranks with the Dunn's test for pairwise multiple comparisons (Zar 1984, Steel et al. 1997). Differences were considered significant at $P < 0.05$.

3.3 Results

Burst Swimming

Mean Velocity (U)

Experiment 1: Oval collecting/holding tank and Pescalator[®] Archimedes-type lift

There were no significant mean swimming velocity differences among fish holding durations (i.e., 4, 6, 8, 12, or 24 h; $P > 0.243$) in any experimental treatments. Consequently, results across durations were pooled, within treatments, for subsequent analyses comparing treatments. Juvenile Chinook salmon mean velocities were

statistically indistinguishable among control, standardized stress, and experimental treatments in all 3 experimental configurations (Table 2; $P > 0.05$). Sample sizes were 65, 38, and 25, respectively, for the oval holding tank, oval holding tank with Pescalator[®], and Pescalator[®] treatments. Mean velocities for these three treatment groups were not statistically different from each other (Fig. 19A; $P \geq 0.604$).

Experiment 2: Cylindrical collecting/holding tank with lift bucket

Because there were no statistical differences among holding durations (i.e., 4, 8, or 12 h; $P = 0.506$), treatment-specific mean swimming velocity data were pooled, within treatments, across all durations. Mean swimming velocities were statistically indistinguishable among control, standardized stress, and experimental treatments in both cylindrical holding tank with lift bucket and lift bucket configurations (Table 2; $P > 0.05$). Sample sizes were 71 for cylindrical holding tank and 24 for the lift bucket. Mean velocities for fish exposed to the cylindrical holding tank with lift bucket and those from the lift bucket alone were similar (Fig 19B; $P = 0.856$).

Experiment 1 vs. Experiment 2: Comparing holding tanks and conveyance methods

The 2005 oval holding tank and Pescalator[®] experiments resulted in significantly lower mean swimming velocities compared to those exposed to comparable treatments in 2006 with the cylindrical holding tank and lift bucket (Fig. 19C; $P < 0.001$). The Pescalator[®] fish showed a significantly slower mean swimming velocity compared to those fish removed with a lift bucket (Fig. 19C; $P < 0.020$).

Maximum Velocity (U_{\max})

Experiment 1: Oval collecting/holding tank and Pescalator[®] Archimedes-type lift

There were no statistically significant differences in juvenile Chinook salmon maximum swimming velocities, within treatment groups, among 4, 6, 8, 12, or 24 h durations ($P= 0.292$), so treatment-specific data were pooled, within treatments, across all durations. There was no detectable statistical difference in mean swimming velocity among control, standardized stress, and experimental treatments in all 3 experimental configurations (oval holding tank, oval holding tank with Pescalator[®], and Pescalator[®]; Table 2; $P \geq 0.099$, $n= 65, 38,$ and $25,$ respectively). There were also no significant differences in maximum velocity among these three experimental configurations (Fig. 20A; $P \geq 0.191$).

Experiment 2: Cylindrical collecting/holding tank with lift bucket

There were no significant maximum swimming velocity differences ($P > 0.637$) across holding durations (i.e., 4, 8, or 12 h), and the treatment-specific results were pooled, within treatments. In our comparisons, cylindrical holding tank with lift bucket fish showed a significantly higher maximum swimming velocity than did standardized stress fish ($P= 0.009$), but were statistically indistinguishable from control fish (Table 2; $P= 0.182$, $n= 71$). There was no detectable statistical difference among control, standardized stress, and Pescalator[®] group comparisons (Table 2; $P= 0.491$, $n= 24$). No statistical differences were found in maximum velocities for fish exposed to the cylindrical holding tank with lift bucket and those from the lift bucket (Fig. 20B; $P= 0.967$).

Experiment 1 vs. Experiment 2: Comparing holding tanks and conveyance methods

Maximum swimming velocities from the 2006 cylindrical holding tank and lift bucket group were higher compared to those fish from the 2005 oval holding tank and Pescalator[®], 64 and 47 cm/s respectively (Fig. 20C; $P < 0.001$). In addition, lift bucket fish reached significantly higher maximum velocities among lift bucket and Pescalator[®] comparisons (Fig. 20C; $P = 0.043$).

Mean Acceleration (A)

Experiment 1: Oval collecting/holding tank and Pescalator[®] Archimedes-type lift

There were no significant mean acceleration differences among durations fish were held (i.e., 4, 6, 8, 12, or 24 h; $P \geq 0.770$) in any of the experimental treatments. Consequently, results across durations were pooled, within treatments, for subsequent analyses comparing treatments. There were no distinguishable statistical differences in mean acceleration among control, standardized stress, and oval holding tank treatment, whereas the oval holding tank with Pescalator[®] group had a lower mean acceleration compared to its control and was not statistically different than the standardized stress comparison (Table 3; $P = 0.012$ and $P = 0.125$, $n = 65$ and 38 , respectively). Pescalator[®] treatment fish had a significantly lower mean acceleration rate than both control and standardized stress groups (Table 3; $P < 0.001$, $n = 25$). Mean acceleration for the oval holding tank, oval holding tank with Pescalator[®], and Pescalator[®] treatments were not statistically different from each other (Fig. 21A; $P \geq 0.269$).

Experiment 2: Cylindrical collecting/holding tank with lift bucket

There were no treatment-specific differences ($P= 0.920$) among the 3 durations tested (i.e., 4, 8, or 12 h), so treatment-specific mean acceleration data were pooled, within treatments, for subsequent analyses. Juvenile Chinook salmon mean accelerations were statistically indistinguishable among control, standardized stress, and experimental treatments in both the cylindrical holding tank with lift bucket and lift bucket experimental configurations (Table 3; $P\geq 0.466$, $n= 71$ and 24). There were also no statistical differences among the cylindrical holding tank with lift bucket and lift bucket comparisons (Fig. 21B; $P= 0.245$).

Experiment 1 vs. Experiment 2: Comparing holding tanks and conveyance methods

The 2005 oval holding tank and Pescalator[®] experiments resulted in significantly lower mean accelerations compared to those exposed to comparable treatments in 2006 with the cylindrical holding tank and lift bucket (Fig. 21; $P= 0.003$). The Pescalator[®] fish showed a significantly slower mean swimming velocity compared to those fish removed with a lift bucket, 10.2 and 21.3 m/s respectively (Fig. 21C; $P< 0.001$).

Maximum Acceleration (A_{\max})

Experiment 1: Oval collecting/holding tank and Pescalator[®] Archimedes-type lift

Because there were no statistically significant differences in juvenile Chinook salmon maximum accelerations, within treatment groups, among 4, 6, 8, 12, or 24 h durations ($P\geq 0.632$), treatment-specific data were pooled, within treatments, across all durations. Fish from both oval holding tank and oval holding tank with Pescalator[®]

comparisons to their respective control and standardized stress groups showed no distinguishable difference in maximum acceleration (Table 3; $P= 0.803$ and 0.070 respectively). However, fish from the independent Pescalator[®] tests did result in significantly lower maximum accelerations compared to their control ($P= 0.034$) and standard stress groups ($P< 0.001$). In our comparisons, oval holding tank, oval holding tank with Pescalator[®], and Pescalator[®] were not significantly different in regards to their maximum acceleration ability (Fig 22A; $P\geq 0.131$).

Experiment 2: Cylindrical collecting/holding tank with lift bucket

There were no significant maximum acceleration differences ($P= 0.933$) across holding durations (i.e., 4, 8, or 12 h), and treatment-specific results were pooled, within treatments. Maximum swimming accelerations were statistically indistinguishable among control, standardized stress, and experimental treatments in both cylindrical holding tank with lift bucket and lift bucket configurations (Table 3; $P\geq 0.402$, $n= 71$ and 24 , respectively). Fish exposed to the cylindrical holding tank and bucket (67.9 m/s) had a significantly slower maximum acceleration compared to those in the lift bucket alone (Fig. 22B; 86.9 m/s, $P= 0.036$).

Experiment 1 vs. Experiment 2: Comparing holding tanks and conveyance methods

Maximum acceleration rates were significantly lower for the 2005 oval holding tank and Pescalator[®] experiments compared to those exposed to comparable treatments in 2006 with the cylindrical holding tank and lift bucket (Fig. 22C; $P= 0.040$). The Pescalator[®] fish also had significantly slower mean maximum acceleration rate compared

to those fish removed with a lift bucket, 51.62 and 86.94 m/s respectively (Fig. 22C; $P < 0.001$).

C-start Angles & Body Curvature

Experiment 1: Oval collecting/holding tank and Pescalator[®] Archimedes-type lift

Differences in duration were not considered for this performance measurement. Because there were no differences between 2005 and 2006 control and standardized stress groups ($P < 0.05$), treatment-specific data were pooled for subsequent analyses. Juvenile Chinook salmon C-start angles were statistically indistinguishable among control, standardized stress, and treatments in all 3 experimental configurations (Fig 23; $P > 0.165$). A biological trend shows increasingly higher angles (but not significant) from oval holding tank to oval holding tank with Pescalator[®] to Pescalator[®] alone. Body contractions in Pescalator[®] fish tended to be less extreme than in oval holding tank with Pescalator[®] fish, which were less extreme than oval holding tank fish (Fig. 23).

Experiment 2: Cylindrical collecting/holding tank with lift bucket

Duration, control, and standardized stress considerations are the same as experiment 1. We found no statistical difference in C-start angles in the lift bucket fish from its control and standardized stress ($P = 0.876$ and 0.061 , respectively). However those fish that were exposed to the cylindrical holding tank with the lift bucket experienced a significantly smaller angle in their C-start compared to the standardized stress group ($P < 0.001$), but not significantly smaller than the control (Fig 23; $P = 0.110$). C-start angles from the cylindrical holding tank with the lift bucket and lift bucket

treatments were statistically indistinguishable ($P= 0.096$); however they did show a similar biological trend to that seen among the cylindrical holding tank treatments (Fig 23).

Experiment 1 vs. Experiment 2: Comparing holding tanks and conveyance methods

In the cylindrical holding tank with the lift bucket, C-start angles were significantly less than those in the oval holding tank with Pescalator[®] ($P= 0.008$) and Pescalator[®] screw lift alone (Fig 23; $P= 0.005$). As a result, bodies of cylindrical holding tank with the lift bucket treatments' fish were more curved than those in the oval holding tank with Pescalator[®] and Pescalator[®] screw lift treatments. Pescalator[®] and lift bucket conveyance methods showed no difference with respect to C-start angle (Fig 23; $P= 0.090$).

Maximum Swimming Performance

Experiment 1: Oval collecting/holding tank and Pescalator[®] Archimedes-type lift

There were no significant maximum swimming performance differences among fish holding durations (i.e., 4, 6, 8, 12, or 24 h; $P\geq 0.404$) in any of the experimental treatments. Consequently, results across durations were pooled, within treatments, for subsequent analyses comparing treatments. Maximum swimming performance decreased stepwise in juvenile Chinook salmon from the oval holding tank to those exposed to the oval holding tank and Pescalator[®], and to those exposed to the Pescalator[®] screw lift alone (Fig. 24A; $P\leq 0.028$; $n= 66, 60, \text{ and } 25$ respectively). The mean number of lines that fish inserted into the oval holding tank crossed were statistically distinguishable from

those in the control fish ($P= 0.006$) and standardized stress ($P< 0.001$). Similarly, fish inserted into the Pescalator[®] screw lift elicited the significantly fewest mean lines crossed (22.0 lines; $P<.001$), which were statistically fewer than its control (37.7 lines; $P= 0.023$) but not statistically less than those exposed to the standardized stress (19.2 lines; $P= 0.883$). Fish exposed to the oval holding tank with Pescalator[®] showed an intermediate maximum swimming performance, compared to those in the oval holding tank and to the Pescalator[®] fish (Fig. 24A), but were significantly higher than those in corresponding standardized stress and control fish, which were indistinguishable from each other (37.1 and 25.3 mean lines for control and standardized stress, respectively; $P= 0.659$). Besides this comparison, standardized stress fish most often had the lowest maximum performance levels.

Experiment 2: Cylindrical collecting/holding tank with lift bucket

There were no significant, treatment-specific differences in maximum swimming performance among experiment durations (i.e., 4, 8, or 12 h; $P= 0.890$), so treatment-specific data were pooled, within treatments, across all durations. Fish that were held in the cylindrical holding tank and removed with the lift bucket crossed significantly more lines than both control and standardized stress groups ($P< 0.001$). Fish exposed to just the lift bucket crossed significantly more lines than the standardized stress group ($P= 0.028$), but were statistically indistinguishable from control fish ($P= 0.059$). Lift bucket fish also crossed far fewer mean lines than cylindrical holding tank with lift bucket, 45 and 100 lines respectively (Fig. 24B; $P= 0.005$, $n= 78$ and 24 for treatment groups).

Experiment 1 vs. Experiment 2: Comparing holding tanks and conveyance methods

Maximum swimming performances for juvenile Chinook salmon in the 2005 oval holding tank and Pescalator[®] experiments were significantly lower than those in the 2006 cylindrical holding tank and lift bucket experiments' fish (Fig. 24C; $P= 0.012$). Lift buckets' fish maximum swimming performance were more than double those in the Pescalator[®] treatments' fish, with means of 45 and 22 lines, respectively (Fig. 24C; $P= 0.002$).

3.4 Discussion

Whole organism performance represents the integration of morphological, physiological, and behavioral traits (Ghalambor et al. 2003). Likewise, burst swimming and predator avoidance maneuvers require the close interaction of neural, muscular, and skeletal components to orchestrate escape responses. Current fish salvage practices often include an element of holding, transport, and release which is presumably stressful and subsequently may increase a fish's vulnerability to predation, both during the process and after release. It is imperative that the salvage processes do not compromise fishes' swimming ability if the fish are to survive predator encounters. Furthermore, stress-induced changes in burst and maximum swimming performance may translate into actual disparities in predator vulnerability.

Fast-starts during burst swimming are typically mediated and controlled by Mauthner cells which operate as a simple neural circuit, a pair of reticulospinal neurons, extending the full length of the spinal cord (Eaton et al. 1977, Eaton et al. 1981, Domenici and Blake 1997, Schriefer and Hale 2004). Mauthner cells are sufficient to

cause the synchronous activation of white musculature along the concave side of a fish during the initial C-shaped positioning (Eaton et al. 1981, Jayne and Lauder 1993) and are the fastest conducting fibers in the fish central nervous system (Wakeling 2006).

Our burst swimming data indicate that there were no statistical differences within treatment groups and few differences among the controls and standardized stress groups for all four burst swimming parameters (i.e., mean velocity, maximum velocity, mean acceleration, and maximum acceleration; Figs. 19-22). Mean and maximum acceleration was significantly less for the Pescalator[®] fish compared to its control and associated standardized stressor (Table 3). This may indicate the high stress level associated with exposure to the Pescalator[®] screw lift, especially considering the increased level of plasma glucose (i.e., fuel reserve) that was detected after these fish were removed from the holding tank (Chapter 2). Pescalator[®] fish were also found to have higher concentration of plasma cortisol compared to other treatments and its control. However, it appears that cortisol elevation has no effect on the swimming performance of juvenile Chinook salmon. Standardized stressed fish that had higher plasma cortisol concentrations did not show a significantly different swimming behavior using our four, burst-swimming parameters. Likewise, elevated cortisol levels alone as a result from handling stress was shown to have no effect on the swimming response of juvenile rainbow trout (*Oncorhynchus mykiss*; Peake et al. 1997, Gregory and Wood 1999). Because the swimming escape response is the main behavioral reaction to stressors in fish, it seems reasonable that the primary stress response hormones (e.g., cortisol) should not impair this tactic (Peake et al. 1997).

It was clear from all four burst-swimming parameters that the performance of fish from the cylindrical holding tank with lift bucket consistently exceeded that of the oval holding tank with Pescalator[®] fish (Figs. 19-23). Additionally, the same trend was evident when comparing conveyance mechanisms. Fish removed from the holding tank using the Pescalator[®] screw lift always exhibited slower mean and maximum velocities and accelerations compared to those of a fish removed via the lift bucket. Using these burst swimming parameters as an index of stress, we conclude that the oval holding tank with Pescalator[®] combination, and more importantly the Pescalator[®], are more stressful during the holding/removal process than the other holding/removal processes and result in slower burst swimming velocities and accelerations. Such decreases in velocity and acceleration (might) indicate an increase in predator vulnerability (Webb 1976, Domenici and Blake 1997). Some of the decreased performance abilities of the Pescalator[®] fish might be attributed to seasonal timing of experiments when the Pescalator[®] effects, alone, were tested. Pescalator[®] experiments were held in July and August of 2005, and it was observed that these fish were undergoing the parr-smolt transformation (smoltification). There was a loss of parr markings and the fish had become silver in appearance, consistent with this transformation. Anadromous salmonids have been reported to lose swimming stamina and performance while they are undergoing the parr-smolt transformation (Glova and McInerney 1977, Thorpe and Morgan 1978, Smith 1982, Flagg et al. 1983, Peake and McKinley 1998). However, the Pescalator[®]-induced effects cannot be ascribed totally to these salmonid developmental differences. Importantly, the oval holding tank with Pescalator[®] tank experiments were performed earlier in the year with parr, which also resulted in lower velocities and accelerations.

Besides smoltification, the size of the fish (TL) and temperature may also influence swimming performance. Burst swimming speed and stamina has been shown to be directly related to size (Webb and Corolla 1981, Taylor and McPhail 1985b, Taylor and McPhail 1985c). Small fish attain higher specific speed (body lengths /s) than larger fish (Domenici and Blake 1997) and the relationship between maximum speed and size is not linear (Wardle 1975, Domenici and Blake 1997). However, we did not observe any statistical differences in burst swimming and maximum swimming performance among our fish due to total length, probably the result of our fish's narrow size distribution. Additionally, Fuiman (1986) showed there was an increase in burst swimming speed with an increase in temperature. However, all of our experiments were conducted within a relatively small temperature range ($\pm 2^{\circ}\text{C}$), decreasing the probability of temperature-related effects.

Comparing burst swimming performances of different species in the literature can be difficult because of different methodologies used and confounding by different filming rates, water temperatures, fish sizes, stimuli, and burst types (Frith and Blake 1995, Domenici and Blake 1997). One considerable source of variation that we noticed in our pilot studies was the degree of reaction to startle devices. Many startle stimulus techniques have been used throughout the burst swimming literature (e.g., electric, acoustic, hand thrust, dip net, banging the side of tank, and a metal bar suspended in the water), but we found that dropping a ball from above provided the most reliable response. Despite methodological differences, our fishs' burst swimming performances were of similar magnitude to other salmonids of the same size. Mean velocities for rainbow trout (103-143 TL) were 30 and 32 cm/s, but could achieve 250 cm/s (Bainbridge 1960,

Beamish 1978). However, maximum velocities were most often reported as 54-80 cm/s (rainbow trout 96-143mm TL; Webb 1976, Webb 1978b, Domenici and Blake 1997). Our salmon's mean acceleration rates ranged over 10.2 -21.3 m/s² and were as high as 89.4 m/s² depending on treatment group, but were as low as 51.6 m/s² under the stressful effects of the Pescalator[®]. Webb (1983) reported maximum acceleration rates of 80 m/s² for a 257 mm rainbow trout, compared with previously published values of 41 and 42 m/s² for smaller rainbow trout (136 and 143mm TL respectively; Webb 1976, Webb 1978b, Domenici and Blake 1997). Generally, mean values of 40 m/s² for fish accelerations have been reported for teleosts (Webb 1978b, Webb 1983).

C-start, body curvature at the end of the propulsion stage of burst swimming kinematics is proportional to the magnitude of the strain undergone by axial musculature (Rome and Sosnicki 1991, Jayne and Lauder 1993) and is directly related to thrust generated (Weihs 1973, Webb 1978a, Taylor and McPhail 1985a). Therefore, body curvature while in the "C" position may be a good indicator of relative burst performance (Webb 1978a, Taylor and McPhail 1985a), and we suggest that the extent of bending is important to the escape response. Superior acceleration rates achieved during the preparation and propulsion stages of a C-start can be explained in part by the maximum angles of attack, high perpendicular velocity, and the large propulsion force produced by the undulation of the body and caudal fin compared to other types of swimming behaviors (Weihs 1973, Jayne and Lauder 1993, Frith and Blake 1995). White muscle is responsible for the majority of burst swimming due to its large muscle mass in most fishes and its contractile properties (Greer-Walker and Pull 1975, Rome et al. 1988,

Wakeling 2006). White muscle fibers are fast; however, they fatigue quickly (Wakeling 2006).

Our juvenile Chinook salmon's startle responses often began with a C-shaped burst configuration before 'leaping' forward. As a result, fish body bends in the cylindrical holding tank with lift bucket treatment were more extreme during the C-start configuration than fish from standardized stress, oval holding tank with Pescalator[®], and Pescalator[®] groups (Fig. 24, $P < 0.05$). A biological trend is apparent in our results, where higher C-start angles (less bending) are more common with more stressful procedures. Standardized stress and Pescalator[®] treatments resulted in fish that had the highest C-start angle ('lazy C' shape). Plasma lactate levels were the least in cylindrical holding tank with lift bucket experiments and greater in oval holding tank with Pescalator[®] and Pescalator[®] treatments than other treatments (Chapter 2), which may partly explain the difference in muscular contractions contributing to body bending (Milligan 1996). Regardless of the trend in these data, only the cylindrical holding tank with lift bucket fish were statistically distinguishable from the other groups. Our fish's four burst swimming parameters and C-start body curvature lacked statistical differences; these data therefore indicate the consistency of our findings among our chosen physiological challenges. Comparisons that we did not detect a difference among body curvatures achieved during preparation and propulsion stages of C-starts also had statistically indistinguishable generated thrusts.

Maximum swimming performance, which combines both burst and sustained swimming, has great potential as an inexpensive, non-labor-intensive practice to measure the stress response at the organismal level. Of all the indices used in our experiments,

this simple method of quantifying swimming performance proved most promising. There was a statistically evident, stepwise decrease in maximum swimming performance for juvenile Chinook salmon exposed to each of the holding tanks and conveyance mechanisms compared to the conveyance methods alone. The number of lines that fish were able to cross was inversely related to the stressfulness of the treatment prior to this challenge test. The Pescalator[®] stood out as the most stressful component of the salvage process tested, with the lift buckets' fish maximum swimming performance more than double those in the Pescalator[®] treatments' fish. When the Pescalator[®] was coupled with the oval holding tank, it reduced the maximum swimming performance of those fish considerably. However, the standardized stress and two conveyance method fish had the lowest maximum swimming performances. Fish in the holding tanks that had been swimming for an experimental duration of 4-24 h seem physiologically 'geared up' up for swimming. Conversely, fish not exposed to the holding tanks did not experience a similar exercise prelude prior to the swimming challenges. Control and standardized stressed fish were sampled directly from their 87-1 tank, and fish placed into the Pescalator[®] and lift bucket had no swim-induced flows prior to the removal process exposure. Energy mobilization was not thought to be responsible for the differential swimming performance, because of abundant plasma glucose (Chapter 2). The loss of maximum swimming performance in our oval holding tank with Pescalator[®] experiments' Chinook salmon was apparently related to reduced contractile properties from muscle fatigue (Chapter 2). Heath et al. (1997) found that larval striped bass (*Morone saxatilis*), Japanese Medaka (*Oryzias latipes*), and fathead minnow (*Pimephales*

promelas) all showed a decline in maximum swimming performance resulting from exposure to a stressor (Heath et al. 1993a, Heath et al. 1993b, Heath et al. 1997).

In all the challenge tests performed, we never witnessed a holding-duration effect. Therefore, we accept our hypothesis that juvenile Chinook salmon held for extended periods of time (>4 h, but ≤ 24 h) will show statistically indistinguishable swimming abilities. Nonetheless, those fish held and swum under low currents in holding tanks resulted in generally superior swimming performance to other groups. Holding durations might be valuable in allowing fish to recover from a prior stressor to reduce subsequent stress. Meyer and Cook (1996) reported that low-level aerobic exercise promotes post-stress recovery in rainbow trout. Handling and transportation may stress fish, leading to direct and indirect mortality during the salvage process and upon release (Wedemeyer 1976, Barton et al. 1986). However, further research is needed to address conditions at both south Delta fish salvage facilities, because our studies lacked debris and predators that can be found mingled in with salvage collections of prey fishes.

Due to the inherent variation among individual fish and the lack of resolution within treatment groups, and among controls and standardized stress groups using our four burst swimming parameters (i.e., mean velocity, maximum velocity, mean acceleration, and maximum acceleration), we recommend measuring additional burst swimming parameters in the future. Time to first reaction from a stimulus might be a valuable burst swimming parameter, which our apparatus and camera angle could not include. Sigismondi and Weber (1988) determined that response times to a stimulus of juvenile Chinook salmon that were subjected to a 30-s handling stress were significantly greater than to those that were not stressed. Longest response times also occurred

immediately after stress and gradually decreased with recovery from stress (Sigismondi and Weber 1988). Fish that were subjected to multiple stressors had fewer tendencies to respond to a stimulus and required longer recovery times than fish that were exposed to a stressor once (Sigismondi and Weber 1988). Our stressed salmon tended to remain motionless either at the bottom or against the side. Stressed fish also seemed oblivious to their surroundings; slow or failing to react to stimuli (i.e., prodding rod, dip net, hand, or predator). Shorter response times could be advantageous in situations where predators or other dangers are present.

We had hypothesized that the cylindrical holding tank with a lift bucket conveyance method would significantly reduce the burst and maximum swimming parameters of juvenile salmon compared to those of control fish and those influenced by the oval holding tank with Pescalator[®] screw lift. We reject this hypothesis because fish exposed to the cylindrical collecting/holding tank with a lift bucket had significantly higher burst and maximum swimming parameters, and increased body bending during C-starts, than an oval holding tank with Pescalator[®] screw lift. Cylindrical holding tank with lift bucket fish were statistically indistinguishable from control fish for all challenge tests. In fact, it was the oval holding tank with Pescalator[®] screw lift, and more importantly the Pescalator[®] itself that caused a significant reduction in burst and maximum swimming parameters.

Ecologically, burst and maximum swimming performance are critical for survival of fishes, whether it is to eat or avoid being eaten. Juvenile Chinook salmon cannot match the swimming ability of larger fish predators, but survival from a predacious encounter often depends on avoiding a single strike. Successful evasion focuses on

proper timing, magnitude (distance, velocity, and acceleration), and direction of the burst response (Webb and Corolla 1981, Fuiman 1986). The effectiveness of a fish as a predator and in avoiding predation depends largely on locomotor performance. Velocity, maneuverability, propulsive power, and endurance are major factors in escaping predator encounters (Howland 1974, Webb and Corolla 1981). Fish require a combination of these swimming-related variables to escape from predation. Swimming performance may provide a mechanical basis for differential susceptibility to predation (Taylor and McPhail 1985c, Olla and Davis 1989). In addition, maximum swimming performance may be the most important factor when a prey fish is persistently pursued by a predator.

Chapter 4

Predator vulnerability of juvenile Chinook salmon
(*Oncorhynchus tshawytscha*): Effects of acute stressors
during simulated salvage practices at screened water
diversions.

4.1 Introduction

Striped bass (*Morone saxatilis*) are highly predacious of Sacramento River Chinook salmon (*Oncorhynchus tshawytscha*) and are the dominant predator in the Sacramento-San Joaquin Delta (Moyle 2002, Tucker et al. 1998). Predation on juvenile fish is high at hatchery and salvage release sites and is one of the major causes of mortality after release (Olla and Davis 1989, Olla et al. 1995, Rieman et al. 1991, Liston et al. 1994, Moyle 2002, OCAP Biological Opinion 2005). High predation at these release sites is likely due, in part, to the sublethal levels of stress associated with handling, crowding, transportation, and possibly screening and salvage experienced immediately before release (Schreck 1982, Maule et al. 1988, Raquel 1989, Olla et al. 1992, Sharpe et al. 1998).

Vulnerability to predators increases after exposure to stressors such as temperature (Sylvester 1972, Sylvester 1973, Coutant 1973, Yocom and Edsall 1974, Webb and Zhang 1994, Marine and Cech 2004), gas-supersaturation (Mesa and Warren 1997), osmotic changes (Handeland et al. 1996), pollution (Hatfield and Anderson 1972, Kania and O'Hara 1974, Brown et al. 1985, Little et al. 1990), starvation (Rice et al. 1997), disease (Mesa et al. 1998), handling (Olla and Davis 1989, Olla et al. 1992, Gadomski et al. 1994, Mesa 1994, Sharpe et al. 1998, Ryer 2002, Davis 2005), and transportation (Carmichael et al. 1983, Robertson 1988, Schreck et al. 1989, Barton et al. 1996). Several of these studies have shown that stressors can elicit physiological and behavioral responses that may result in behavioral impairments and increased vulnerability to predation. However, there have been few studies correlating ecological consequences of abated performance to stress-associated biochemical changes. If

biochemical changes are not linked to organism-level responses, the validity of applying such measures to population or ecosystem levels becomes remote. If striped bass and other piscivores feed preferentially on fish that are impaired or injured during transportation and salvage practices, then mortality of released fishes may be much higher than currently anticipated. Although, the effects of stress are the most ecologically relevant at the population and community levels, these effects may be difficult to determine. Past studies have focused on chemo-physiological changes as a result of stress or specific challenge tests (e.g., critical swimming speeds and burst swimming), but not directly on predation (Deitinger and McCauley 1990, Barton and Iwama 1991).

Predation challenges represent an integration of behavioral and physiological processes, and provide insight to the effects of molecular and cellular changes at the ecological level. One of the most commonly used techniques for accessing prey susceptibility to predation is the predator preference challenge (Cada et al. 2003), which entails combining groups of sublethally stressed and unstressed individuals and exposing them to predators. It is generally accepted that predators typically capture substandard individuals disproportionately from healthy prey (Temple 1987, Gadomski and Hall-Griswold 1992). Potential drawbacks to this technique, including its terminal outcome and sacrifice may not be possible with endangered and threatened fishes which may limit the predation challenge test's applicability.

Fish entrainment is increasingly perceived by biologists, fisheries managers, and the public as an undesirable consequence of delivering water. Attempts to decrease mortality rates of juvenile Chinook salmon at water diversions and south Delta state and

federal fish salvage facilities have led to important advancements in screening practices and operations in Northern California. However, researchers have speculated that mortality can be directly attributed to salvage practices and indirectly by predation at the facilities and release sites where predation may be a significant source of mortality (Liston et al. 1994, Sharpe et al. 1998, OCAP Biological Opinion 2005, Kimmerer and Brown 2006).

The objective of this study was to evaluate the effects of two types of collecting tanks and fish-salvage strategies on predator avoidance ability and physiological stress of juvenile Chinook salmon. If stress decreases swimming performance and the ability of fish to react quickly to predator attacks, it could decrease their survival during the salvage process and after release. To minimize the harmful effects of fish salvage, including direct and indirect mortality, it is necessary to quantify the stress associated with different components of the collection and holding process. Our focus was to assess whether the collecting/holding tanks, transfer designs, and duration of holding physiologically affect juvenile Chinook salmon's vulnerability to predators. We hypothesized that the cylindrical collecting/holding tank with a lift bucket conveyance method, currently used to transfer fish from holding tank to transporting vehicle, would significantly decrease the survival of juvenile salmon during a predator challenge compared to that of an unstressed, control fish and that of fish collected in an oval holding tank with the Pescalator[®] Archimedes lift. For example, an oval holding tank design with different velocities for fish to select around the tank due to its near-elliptical shape and traveling screens to remove debris may decrease confinement and abrasion. The Pescalator[®] Archimedes lift may transfer salvaged fish more carefully, without air exposure, to a fish

hauling truck (Conte 2004). Furthermore, we hypothesized that juvenile Chinook salmon held for extended periods of time (i.e., >4 h, but ≤ 24 h) will show statistically indistinguishable predator survival abilities.

4.2 Materials and Methods

Source and Care of Fish

Sacramento River Chinook salmon (*Oncorhynchus tshawytscha*) used in this study are commonly entrained and of special concern at the Tracy Fish Collection Facility (TFCF), Tracy, California. Chinook salmon were obtained in 2005 and 2006 from the Coleman National Fish Hatchery (Anderson, California) and transported to the U.S. Bureau of Reclamation's Hydraulic Laboratory (Denver, Colorado). Juvenile fall-run Chinook salmon were considered surrogates for winter-run Chinook salmon, which are of significant conservation value (i.e., federally and state listed endangered species) and not available in sufficient numbers for this experiment. Salmon were maintained in 757-l circular tanks equipped with an aerated, partial recirculating water system to deliver water continuously along with dechlorinated, air-equilibrated municipal water. Water temperatures were maintained at 18°C and flow direction was altered weekly for symmetrical muscular development while swimming into the gentle current. Salmon were held under a natural photoperiod (38° N latitude) with natural and halogen light, and were fed BioOregon (BioOregon Inc., Longview, Washington) semi-moist pellets at 1.5-2% body weight per day.

Twenty-five striped bass (ca. 400 mm TL) were obtained from the TFCF salvage for use as predators in predator avoidance experiments. These fish were held in 5 large,

(2.2-m-diameter) polyethylene tanks at a density of 5 fish per tank. Striped bass were fed a maintenance diet of live juvenile Chinook salmon during acclimation and between experiments, and were deprived food for 2 days before a predation challenge to insure a standardized hunger level for experiments. The five tanks were supplied with a continuous flow of water from a 1 h.p. submersible pump delivering 227 l/min. Temperatures were held relatively constant ($19.5 \pm 1^\circ\text{C}$, mean \pm range) throughout the duration of the project. Striped bass were held under a natural photoperiod (38° N latitude) with natural and halogen light.

Fish were marked to differentiate treatments in predation experiments. Treatment and control groups of salmon were marked with implanted, white microspheres on caudal and anal fins with a high pressure needle (Photonic tagging; New West Technology, Arcata, California). Salmon were allowed to recover for at least two weeks after marking before use in experiments. This type of marking is only detectable under ultraviolet lighting and therefore is cryptic to striped bass predators (Losey et al. 1999). Also, this method was less severe/invasive, compared with other techniques such as fin clipping or Floy tagging, and presumably did not affect the salmon's stress response (Hayes et al. 2000).

Groups of 20 Chinook salmon (103 ± 7 mm, mean \pm standard deviation, TL in 2005 and 105 ± 6 mm TL in 2006) were transferred to 87-l, circular polyethylene tanks in a staging area 3 days before an experiment to acclimate to Hydraulic Laboratory water conditions and be in close proximity to the experimental holding tanks where stress responses were evaluated. Salmon carrying the same mark were held in one of four randomly selected 87-l tanks (i.e., 2 control groups, 1 standardized stress group, and 1

treatment group) under constant water flow at $19.5 \pm 1^\circ\text{C}$ throughout the duration of the study from February through August 2005 (Experiment 1) and April through August 2006 (Experiment 2). Salmon were fed once daily in the staging area, except for 24 hours before experimental use.

Experiment 1: Oval collecting/holding tank and Pescalator[®] Archimedes-type lift

Juvenile Chinook salmon's susceptibility to predation was evaluated in 2005 for each experimental group (control fish, standardized stress fish, and treatment fish from the oval holding tank, and oval holding tank and Pescalator[®] under different holding durations within the tanks: 4 h, 6 h, 8 h, 12 h, 24 h, and for the Pescalator[®] independently). The oval holding tank flows ($0.226 \text{ m}^3/\text{s}$) and weir heights (1 m) were set, and 20 juvenile Chinook salmon were inserted into it by gently submerging the 87-l tank and allowing the fish to swim out. To separate stresses inherent in components of the collection/holding process, the experiment was divided into three major parts: the oval holding tank and Pescalator[®] together; the oval holding tank alone; and the Pescalator[®] alone (Fig. 3). Juvenile salmon were collected and sampled after they were held in the oval holding tank for a randomly selected duration (i.e., random draw). For oval holding tank and Pescalator[®] together assessments, fish were removed from the tank by the Pescalator[®] screw lift and conveyed into a 1500-l, cylindrical plastic tank with an internal crowder net making the salmon readily accessible and minimizing chasing/netting stressors. While performing independent oval holding tank assessments, salmon were diverted at the mouth of the Pescalator[®] and transferred into a rectangular 1500-l tank with an internal crowder to increase the ease of capturing salmon and

minimizing chasing/netting stressors. Each of these components was studied for a several-week period, due to the required reconfiguration of the experimental system.

Experiment 2: Cylindrical collecting/holding tank with lift bucket

Susceptibility to predation was evaluated in 2006 for each experimental group (control fish, standardized stress fish, and treatment fish from the cylindrical holding tank and lift bucket under different holding durations within the tanks: 4 h, 8 h, 12 h, and for the lift bucket independently). After the 2005 experiments, we determined that there were no significant differences in stress responses among holding durations. Therefore, we increased our replicates within a decreased number of durations to improve statistical rigor. Tank flows ($0.226 \text{ m}^3/\text{s}$) and stage heights (1 m) were set and juvenile Chinook salmon were inserted into it by gently submerging the 87-l tank and allowing the fish to swim out. This experiment was divided into two parts, reflecting relevant components: the cylindrical holding tank and lift bucket together, and the lift bucket alone (Fig. 5). Independent cylindrical holding tank assessments could not be made without inflicting significant capture and handling stress, precluding the value of such data from our study. For cylindrical holding tank and lift bucket assessments, salmon were removed from the cylindrical holding tank into the lift bucket. Juvenile Chinook salmon were collected and sampled after they were held in the cylindrical holding tank for a randomly selected duration (i.e., random draw). These fish then were released into the rectangular 1500-l tank with an internal crowder that was positioned under the lift bucket on a trolley system to pull fish out from under the tank for sampling. To assess the lift bucket independently from the tank, salmon were inserted directly into the 1890-l lift bucket by submerging the

87-l tank of fish. Salmon then were released from the lift bucket into the rectangular, 1500-l tank. Due to a tank wall failure, the cylindrical holding tank/lift bucket and lift bucket experiments were conducted during separate times of the year.

Predator challenge

These experiments were used to assess the susceptibility of Chinook salmon parr to predation involving mixed groups of sublethally stressed (treatment) fish and unstressed (control) fish and exposing the mixed groups to a predator fish. Five large striped bass (ca. 400 mm TL) in each of five, 2.2-m diameter 1-m height polyethylene tanks were acclimated to being fed through a prey-release tube. Seven juvenile Chinook salmon were captured and removed from respective 1500-l tanks with modified 10-cm x 18-cm dip nets with a 1.5-l plastic reservoir sewn into the cod-end, so that fish could be transferred in water to minimize stress, and transferred to an opaque, polyvinyl chloride (PVC) 38-l prey release tube with a false bottom. Seven control fish were netted and transferred with the modified nets from a previously undisturbed 87-l tank to the prey release tube. Treatment and control salmon transfers were accomplished quickly (<60 s) with minimal disturbance and handling trauma. Lastly, seven standardized stress fish were held in a conventional 10-cm x 18-cm dip net for 30 s before transferring them to the prey release tube. This standardized stress treatment has been used in many past studies on Chinook salmon and other species, making it a useful standard for comparing stress responses among species (Barton et al. 1980, Barton et al. 1986, Haney et al. 1992, Barton 2000, Barton et al. 2000). The prey-release tube was then submerged in the predation tank for simultaneous release of the 21 salmon. The juvenile Chinook salmon

were left with striped bass predators for 5 minutes or until approximately half were eaten (e.g., 1-2 minutes), when the test was terminated. Remaining (surviving) salmon were netted, anesthetized using 70 mg/l MS-222, checked for treatment type (ultraviolet lamp), weighed (± 0.01 g), and measured (TL, ± 1 mm).

All procedures described above were approved by the University of California, Davis, Animal Care and Use Committee (IACUC Animal Protocol #10879). Applicable State and Federal permits were obtained to conduct research with Chinook salmon in California (Endangered Species Act Research Permit #1027, Endangered Species Act Section 10 Permit, California Scientific Collecting Permit #801159-05) and Colorado (State of Colorado Fish Importation Permit # 04IMPT154).

Data Analyses

Proportions of surviving fish from each group were compared to determine if juvenile Chinook salmon that are stressed by collecting/holding during TFCF-type salvage practices differ from control or standardized stress regarding vulnerability to predation. Statistical analyses were performed using SAS 9.1 (SAS Institute Inc., Cary, North Carolina) and Sigmastat 3.0 (Jandel Scientific, San Rafael, California) software packages. Differences between treatments, control, and standardized stress groups were tested using an unbalanced 3x5 (3x3 for cylindrical holding tank data) factorial design; control, standardized stress, and holding tank in 5 (3 for cylindrical holding tank data) fixed durations (hours). The experiment was organized as a random complete block design (RCBD) analysis of variance (ANOVA) with each group of the 5 (3) durations constituting a block, blocks nested within hours with hours fixed (Steel et al. 1997).

Normality and homogeneity of variance were evaluated for both raw and transformed data with the Shapiro-Wilk's normality test and the Levene's test for homogeneity of variances. Data that did not meet the ANOVA assumptions and were unable to be power or log transformed were compared with a Kruskal-Wallis non-parametric analysis of variance on ranks with the Dunn's test for pairwise multiple comparisons (Zar 1984, Steel et al. 1997). The Tukey's test was used for all pair-wise multiple comparisons for parametric data. Non-parametric tests were used because transformations provided no statistical improvement for data normality and homogeneity of variance. Data transformations generally offer no data normality improvement for data given as a percentage where most of the data are between 30-70% and has few 0 and 100% values (Steel et al. 1997). Wilcoxon-Mann-Whitney two-sample rank-sum tests were used in two-treatment comparisons. Differences were considered significant at $P < 0.05$.

4.3 Results

Predator challenge

Experiment 1: Oval collecting/holding tank and Pescalator[®] Archimedes-type lift

There were no significant survival differences among fish holding durations (i.e., 4, 6, 8, 12, or 24 h; $P > 0.441$) in any experimental treatments. Consequently, results across durations were pooled, within treatments, for subsequent analyses comparing treatments. Effects of stress were clearly manifested in vulnerability to predation. A significantly greater percentage of standardized stress treatment fish were eaten compared to control and the oval holding tank treatment fish (Fig. 25A; $P < 0.05$). The survival of control and oval holding tank treatment salmon were statistically indistinguishable ($P =$

0.612). Oval holding tank and Pescalator[®], and Pescalator[®] treatments compared to their associated control and standardized stress groups were not statistically different ($P=0.137$ and 0.126 , respectively), however they did show a similar biological trend to that seen among the cylindrical holding tank treatment where the control fish had the greatest survival and standardized stress fish had the least (Fig 25B, C). Survival of juvenile Chinook salmon from striped bass predation was statistically indistinguishable whether the salmon were exposed to the oval holding tank, oval holding tank and Pescalator[®] or the Pescalator[®] screw lift alone (Fig. 27; $P=0.435$).

Experiment 2: Cylindrical collecting/holding tank with lift bucket

There were no significant survival differences ($P=0.170$) across holding durations (i.e., 4, 8, or 12 h), and the treatment-specific results were pooled, within treatments. Stress-associated vulnerability to predation was evident in our data with control fish having the highest survival, standardized stress fish showing the lowest survival, and the cylindrical oval tank with lift bucket, and lift bucket fish exhibiting an intermediate response (Fig. 26A). A significantly greater percentage of standardized stress fish were eaten than control fish in both the cylindrical holding tank with lift bucket and lift bucket experiments (Fig. 26B; $P<0.025$). However, cylindrical holding tank with lift bucket fish had survival percentages that were not significantly distinguishable from those of either control ($P=0.512$) or standardized stress groups ($P=0.289$). Survival among fish encountering the lift bucket alone was less than that of the control ($P=0.027$) but statistically equivalent to the standardized stress (Fig. 26B; $P=0.973$). Predation survival for lift bucket fish was significantly greater than that of

cylindrical holding tank with lift bucket fish (Fig. 27; $P < 0.001$), although this strong difference may be influenced by the decreased level of foraging experience by the predators in lift bucket experiments.

Experiment 1 vs. Experiment 2: Comparing holding tanks and conveyance methods

The 2005 oval holding tank and Pescalator[®] experiments resulted in salmon survival rates that were statistically indistinguishable from those exposed to comparable treatments in 2006 with the cylindrical holding tank and lift bucket (Fig. 27; $P > 0.05$). The lift bucket resulted in the highest mean survival rate, but was not significantly greater than that in fish exposed to the Pescalator[®] fish conveyance method ($P < 0.065$).

4.4 Discussion

The physiological condition of prey fish is an important factor to consider in predator-prey interactions. Sacramento River Chinook salmon experience a gauntlet of stressors on their migration to the sea. Water quality changes, contaminants, handling, and salvage may plague salmon health making them more susceptible to predation (Brown et al. 1985, Little et al. 1990, Olla et al. 1992, Gadomski et al. 1994, Barton et al. 1996, Davis 2005). Substandard individuals may be captured disproportionately higher than healthy prey by predators due to their increased vulnerability (Temple 1987, Mesa et al. 1994). It was evident in our findings that the effects of stress had cascaded into increased predator vulnerability, a tertiary stress response (Chapter 1). Standardized stress salmon exposed to a 30-s air immersion were more vulnerable to predation than control fish in most cases and salmon from oval holding tank experiments. While

differences were not statistically significant in all other experiments, they showed a similar trend in which the most stressful experience (i.e., 30-s air immersion) evoked the lowest survival rate, unstressed control fish had the highest survival, and holding tank with conveyance treatments exhibited an intermediary survival. Along with the plasma constituents and swimming performance findings from these simulations (Chapters 2 & 3), these results suggest that physiological stress decreased predator-evading behavior or performance in juvenile Chinook salmon and may decrease survival of predator-prey encounters associated with fish salvage holding and conveyance systems. Cada et al. (2003) also found an overall trend toward greater consumption of stressed prey over that of the controls and found that duration of stress had no apparent impact on predator preference. Similarly, the non-significant holding durations in our studies did not affect prey vulnerability.

Impairment of orientation and startle responses is detrimental to predator evasion (Davis 2005). Our standardized stress fish seemed lethargic and disorientated after a 30-s air immersion and showed decreased reactions towards the striped bass predators. Also, fish that were similarly stressed showed less consistent responses to startling stimuli (Chapter 3). Thus, changes in escape/startle behaviors (e.g., stimuli responsiveness, predator recognition, and C-starts) may be useful in determining the outcome of predator-prey encounters and the relationship to stress and indirect mortality (Mesa et al. 1994, Cada et al. 2003). These impairments may be a useful proxy for delayed or indirect mortality because they integrate the harmful effects of handling and salvage-related stress and are ecologically relevant indicators of environmental stress (Schreck et al. 1997, Davis 2005).

Survival percentages for our lift bucket experiments along with its associated control and standardized stress groups were elevated, compared with those for our other, respective, experimental groups, due to the naivety of the striped bass to the predator challenge tanks and experimental feeding process. Because lift bucket experiments were performed before testing other configurations, only 3 weeks after striped bass predators had been placed into predator challenge tanks, there was more predation variability associated with their reliable feeding in a relatively confined tank environment with prey introduced through a release tube. Subsequent experiments showed increased predation efficiency on all groups, demonstrating the value of including associated control and standardized stress groups for each experimental treatment. Therefore, we attribute the greater survival of lift bucket-exposed and associated experimental salmon to “untrained” predators, rather than to the lift bucket design. Increased replication and decreased variance regarding predators’ prey conditioning might help to determine more subtle predation-rate differences in future experiments.

From a fish-management perspective, the effects of the holding tanks and conveyance systems on fishes at south Delta State and Federal fish salvage facilities in Northern California, may be more stressful than the levels revealed from our laboratory experiments, due to multiple stressors that salvaged fish encounter prior to reaching the holding tanks. Similarly, there is concern that salmon may not be able to accommodate subsequent stressors after experiencing salvage processes at water diversions and these fish salvage facilities (Raquel 1989, OCAP Biological Opinion 2005). If fish stressed by components of the salvage process are more vulnerable to predation, associated mortality could be minimized by either changing practices or facilities to less stressful ones or by

minimizing exposure to these processes. A variety of sublethal stressors, not unlike those experienced by fishes during the salvage process, are known to compromise swimming and behavior leaving fish more vulnerable to predation (Chapter 3, Olla and Davis 1989, Olla et al. 1992, Mesa 1994, Mesa et al. 1994).

The plasma constituent analyses from this study (Chapter 2) provided insight into the different treatment group's physiological condition and their distinct responses. Our data demonstrate handling and removal processes during the holding component of the salvage process elicit physiological responses, but did not result consistently in direct mortality or increased vulnerability to predation. There is little, previous information documenting a clear relationship between cortisol concentration and predator avoidance ability (Olla et al. 1992, Gadomski et al. 1994, Mesa 1994). However, Schreck et al. (1989) found that an extended plasma cortisol increase indicated a reduced relative fitness of stressed coho salmon and resulted in lower survival rates after hatchery coho were released. Although not statistically significant, biological trends in our predator-exposure survival data and plasma constituent analyses (Chapter 2; i.e., cortisol, lactate, glucose) suggest a strong, positive relationship between the degree of stress and vulnerability to predation. Rapid burst swimming, which may be associated with predator avoidance usually, increases concentrations of plasma lactate, which can decrease swimming capacity (Milligan et al. 2000). In addition, the prolonged elevation of plasma cortisol after a stress bout prolongs the recovery of blood acid-base status, muscle glycogen, and lactate levels in swimming fish (Milligan et al. 2000). Elevated lactate levels could consequently lead to higher risk of predation. In our experiments, the predators usually attacked from close ranges, and if the initial attack was unsuccessful,

they would turn and a short pursuit would follow. Therefore, burst swimming stints lasting only seconds may determine outcomes of predator encounters for both predators and prey. Allowing fish to recover chemo-physiological homeostasis and muscle metabolites before release should provide fish a better opportunity to avoid predators than in a stressed state (Farrell et al. 2001a). More research is needed to fully understand the relationship of physiological stress and behavioral aspects of predator avoidance.

Our results suggest that releasing fish that have experienced salvage, handling, and/or transportation-related stresses should occur after sufficient time to acclimate to water conditions of the release site and to regain their predator evading ability. For example, our standardized stressed fish typically had lower mean survival, though not always significantly lower, compared with controls, which had 3 days acclimation with no handling stress prior to the predation challenge. Juvenile salmonids are capable of avoiding predators soon after experiencing a stressful situation, but recovery may take >1 hour (Olla and Davis 1989, Olla et al. 1992, Mesa 1994, Davis and Parker 2004, Ryer et al. 2004). Olla et al. (1995) found that a 1-min handling stress induced a behavioral impairment to predator evasion that took up to 24 hours for recovery in Pacific salmon. On the other hand, stress impaired the ability of coho salmon to avoid predation, but there was no difference in predation mortality of stressed and unstressed fish after 90 minutes post-stress (Olla et al. 1992). In general, juvenile salmon quickly recover basic survival skills of predator avoidance after mild stress, even though cortisol levels continue to indicate a stressed condition up to 24 h post-stress (Olla et. al 1992, 1995). Results from our experiments and recovery information in the previously mentioned literature would

suggest that net pens at release sites may be beneficial in allowing fishes to recover from salvage and transportation-related stressors before release back into the river.

The application of our results to fish in the wild is limited by the lack of physical or light-associated cover in our predation challenge tanks and the prey salmon's naivety to predators, given that they were hatchery-reared. For example, predator-associated mortality at release sites may be decreased with releases at night. All of our studies were conducted under light conditions, during daylight hours. Sylvester (1973) determined that darkness greatly increases survival from predation in both stressed and unstressed fish. The hatchery history of our fish may not have significantly skewed our findings, considering the large proportion of hatchery-produced smolts migrating in California rivers (Dettman and Kelley 1987, Myers et al. 1998, Yoshiyama et al. 1998, Yoshiyama et al. 2000), and some evidence that predator avoidance in juvenile Chinook salmon does not change with prior predator encounters (Healy and Reinhardt 1995). This study and ongoing research will provide valuable information to modify release site operations to enhance fish survival.

Chapter 5

Conclusions: The value of the functional continuum for examining fish salvage-related stress effects

The response to stress is a normal, adaptive pathway that has evolved in association with a vertebrate's attempts to overcome real or perceived stressors and quickly recover to maintain physiological homeostasis. It is a common misconception that evidence of a stress response always indicates a physiological state that is detrimental to the fish's well being. Only when a fish's ability to maintain homeostasis is overtaxed, because of the severity and/or prolonged exposure(s) to stressors, do its homeostasis and "overall health" become compromised, adversely affecting all levels of its biological and ecological organization (Barton and Iwama 1991). While injurious stressors may cause dramatic responses, milder stimuli evoke similar stress responses to enable an organism to cope by either removing the stressor or facilitating coexistence (Antelman and Caggiula 1990). The adaptive mechanism addressing stressors may be as simple as switching from anabolism to catabolism allowing access to a previously unavailable source of energy, or as complex as eliciting a corticosteroid through the HPI axis (Barton and Iwama 1991, Wendelaar Bonga 1997).

Responses to stress at hierarchal levels of organization (i.e., biochemical, organismal, population, community, and ecological) are interconnected and many times are functionally regulated by one another creating a functional continuum (Barton et al. 2002). Therefore, to fully comprehend and value an organism's response to stress at ecological levels, it is important to include whole-body stress responses, rather than observing potentially isolated chemo-physiological responses, only. Although, measuring blood plasma constituents is the most commonly used approach to evaluate physiological stress responses of fish to environmental stressors (Pickering 1981, Barton and Iwama 1991, Iwama et al.1995), some of these may reflect a normal response to very

mild stressors or to daily, rhythmic fluctuations in body chemistry from which a fish can quickly recover (Wendelaar Bonga 1997, Barton et al. 2002). Stress effects on fish cannot be adequately evaluated by measuring either a single stress response or multiple responses from one level of biological organization (e.g., plasma constituents), because the sensitivity of fish to stress is not constant across all stressors (Heath 1987), and no single variable is adequate for interpolating or predicting changes at the population or community levels (Capuzzo 1985). If biochemical changes are not linked to organism-level responses, the validity of applying such measures to population or ecosystem levels becomes remote. It also may be difficult to predict the outcome of a primary stress response on higher order responses because many physiological mechanisms have synergistic effects. Some stress responses (e.g., secretion of hormones), in addition to their direct effects, possess collateral consequences that may not reinforce the primary objective (Greenberg et al. 2002). Unintended actions or inactions may have harmful effects that are amplified from the sub-cellular level to higher levels of organization altering both behavioral and physical abilities (Adams 1990). Therefore, because of these complications in stress responses, a reliable assessment of fish well being and performance should not be restricted to an examination of internal chemo-physiological changes alone. A more comprehensive assessment should include an examination of chemo-physiological changes and compromised performance over a functional continuum.

We assessed chemo-physiological changes and compromised performance over a functional continuum in juvenile Chinook salmon (*Oncorhynchus tshawytscha*) that were exposed to simulated salvage-tank-related stresses. These assessments covered

proximate (e.g., blood plasma constituents), performance (e.g., maximum swimming performance, burst swimming, and C-start responses), and ecological measurements (e.g., predator avoidance), in evaluating the physiological condition of control, standardized stress, salvage tank treatment fish (i.e., oval holding tank with Pescalator[®] and cylindrical holding tank with lift bucket) under 5 different holding durations (4 h, 6 h, 8 h, 12 h). We argue that performance tests are particularly powerful tools for assessing stress because they incorporate several levels of biological organization and are therefore interrelated. Chemo-physiological responses and performance variables should be chosen carefully for their relevance and connectivity when attempting to predict outcomes at the ecological level.

Our results indicate that stress is interrelated functionally from biochemical, organismal, to population and community levels of organization in this species and life stage and show the value of the functional continuum approach in identifying stress-related effects of the fish salvage process. Elevated plasma cortisol levels resulted from juvenile Chinook salmon experiencing stressful treatments (e.g., standardized stress and Pescalator[®]) and if these stressors were given ample time before measurement an increase in plasma glucose and plasma lactate was also evident. These constituents may take a matter of minutes to appear in the plasma in significant concentration (Barton et al. 2002). Control fish did not show the same plasma constituent concentrations as the treatment fish (see Chapter 2). Treatment groups that demonstrated significant primary stress responses also showed a decreased maximum swimming performance and body bending in C-start startle responses (see Chapter 3). The number of lines that fish were able to cross during maximum swimming performance challenges and the degree of body

bending during C-starts (i.e., tighter C-shapes) were inversely related to the stressfulness of the treatment prior to this challenge test, as indicated by plasma cortisol concentrations (see Chapter 3). There was a decrease in maximum swimming performance in oval holding tank with Pescalator[®] and Pescalator[®] treatment fish, compared to cylindrical holding tank with lift bucket and lift bucket fish, which corresponded to what was previously thought to be a more stressful fish holding and removal process. Maximum swimming performance, which combines both burst and sustained swimming, has great potential as an inexpensive, non-labor-intensive practice to measure the stress response at the organismal level and proved to be one of the most reliable measures during our study. Reduced swimming and escape performances due to sublethal stresses may increase prey susceptibility to predators (Olla et al. 1992, Strange and Cech 1992, Mesa et al. 1994). Unfortunately, due to the inherent variability associated with swimming speeds of juvenile Chinook salmon, we were unable to find clear, statistical differences among our control, standardized stress, and most of our treatments (see Chapter 3). Both mean and maximum velocities and accelerations did not seem to be affected by fluxes in plasma constituents and had no clear relationship with predator preference. However, it was evident that oval holding tank with Pescalator[®] and Pescalator[®]-associated treatment fish were slower compared to cylindrical holding tank with lift bucket and lift bucket fish. Differences in swimming ability were apparently related to the degree of treatment stressfulness and inversely related to the plasma cortisol response (i.e., treatments with increased cortisol resulted in slower mean and maximum velocities and accelerations). Swimming performance and escape behavior tests are advantageous because they are not confounded by as many behavior problems associated with predation challenges, are

more straightforward to perform, can be conducted in the lab or field, and do not require sacrificing fish (Cada et al. 2003). In addition, maximum swimming performance and escape behavior tests, such as C-start responses, indicate sublethal stress effects that are comparable to those exhibited in the predator preference challenges (see Chapter 4).

Stress effects that are detectable at the sub-cellular, cellular, and organismal levels should also be noticeable and conserved across all higher levels of biological organization if they affect organismal performance (Wainwright 1994). To test this, we performed predator preference challenges to observe stress-associated effects at the population and community levels (see Chapter 4). It is generally accepted that predators typically capture substandard individuals disproportionately from healthy prey (Temple 1987, Gadomski and Hall-Griswold 1992). Hence, those fish that are severely stressed or physiologically compromised should be noticeable. Results from the predator preference challenges revealed a direct relationship between survival and maximum swimming performance and C-start body curvature, and inversely to plasma cortisol levels. Consequently, there was a decreased survival among standardized stress fish, and control fish exhibited the highest survival (see Chapter 4). Thus, our experimental results support the contention that responses to stress at the ecological level (e.g., predation vulnerability) integrate sufficiently several behavioral and physiological processes.

Biologists continue to search for a single, all-purpose method of measuring stress that will predict ecological outcomes. However, no single method or index can provide all the integrative information, due to the interconnected and inter-regulated nature of the stress response, to predict a fish's post-stressor condition and behavior at the ecological level (Cairns and Van der Schalie 1980). Through examination across a stress-response

continuum, our experimental approach demonstrated many inter-relationships among measured stress responses in juvenile Chinook salmon. Although stress assessments at specific levels of biological organization have been conducted in the past, measuring stress and relevant performance-related responses across a functional continuum in a single experiment had not been achieved. By elucidating the significant relationships across the variables, four advantages have been gained. First, the relationships among physiological/biochemical stress responses and critical measures of organismal performance (e.g., swimming) have been quantified. Second, more specific stress-related effects of the fish salvage process and environmental stress in general, which should increase the predicted usefulness of determining their influence on fish populations, have been identified. Third, our results provide a scientific basis for using a straightforward, inexpensive stress-assessment method (e.g., annular-racetrack maximum swimming performance) for salvaged, juvenile Chinook salmon. Finally, fruitful topics for future research (e.g., including examination of more lasting effects of salvage-related stressors on growth and reproductive performance can be addressed in species with shorter life spans (e.g., smelts). Such studies would build on knowledge gained in this study, and others, towards a more quantitative understanding of the bioenergetic costs attributed to organismal stress in vertebrates (Lankford et al. 2005).

Appendix 1

Figures and Tables

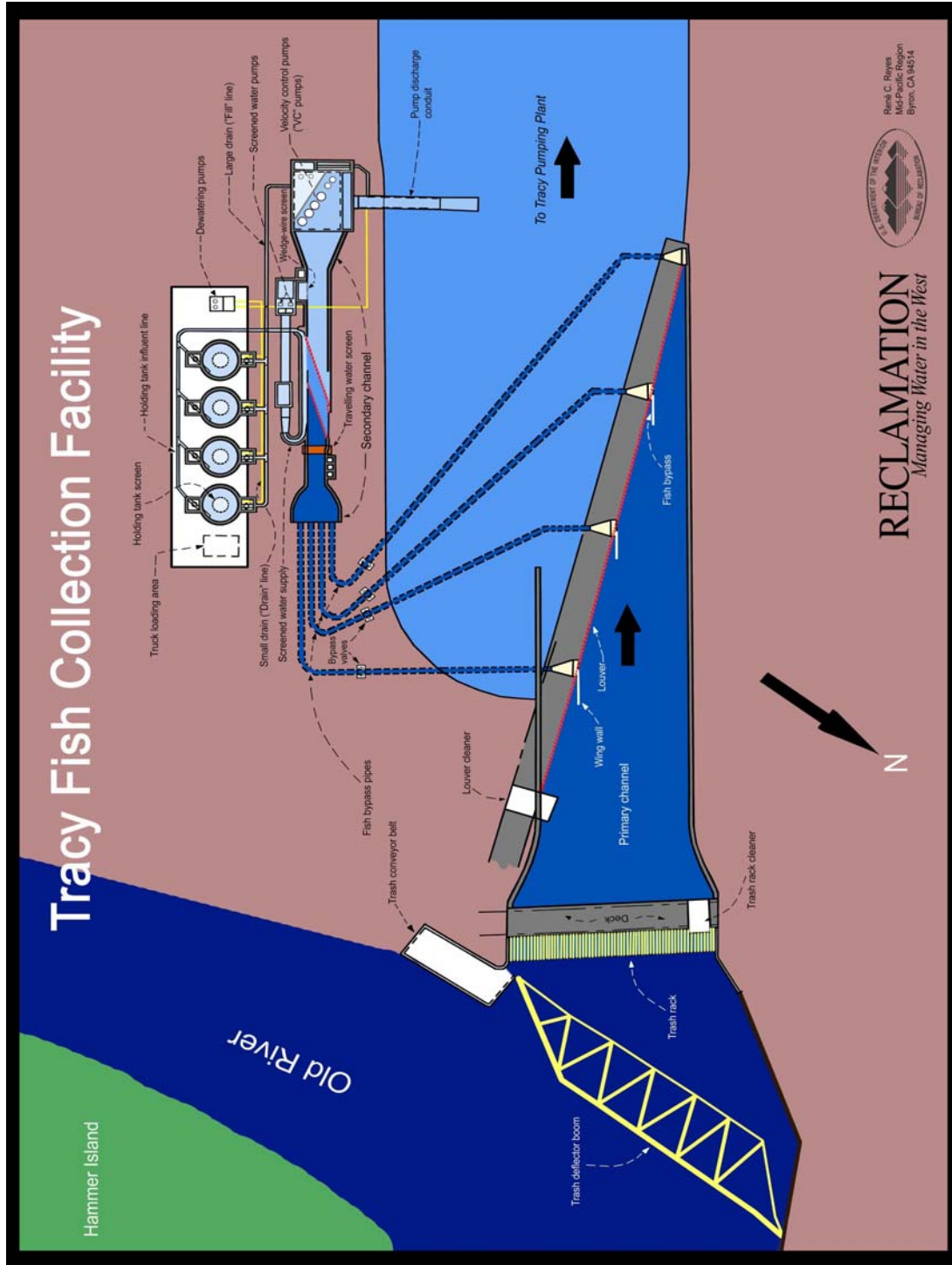

Fig. 1. Schematic of the Tracy Fish Collection Facility, Tracy, California.

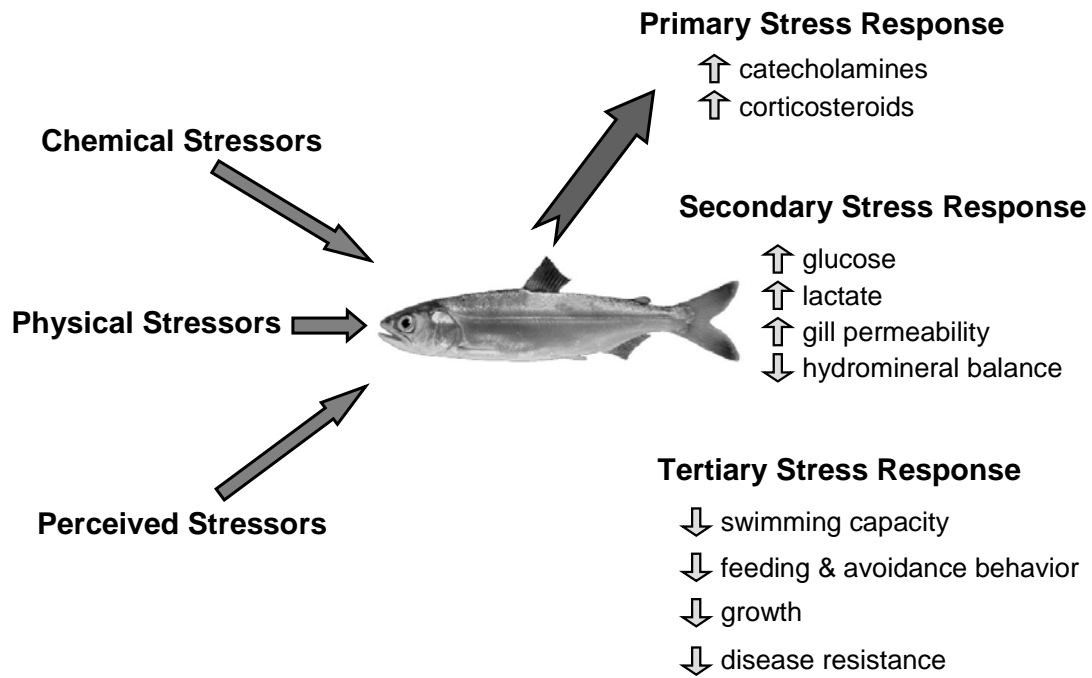

Fig. 2. Physiological responses to stressors (modified from Barton 2002).

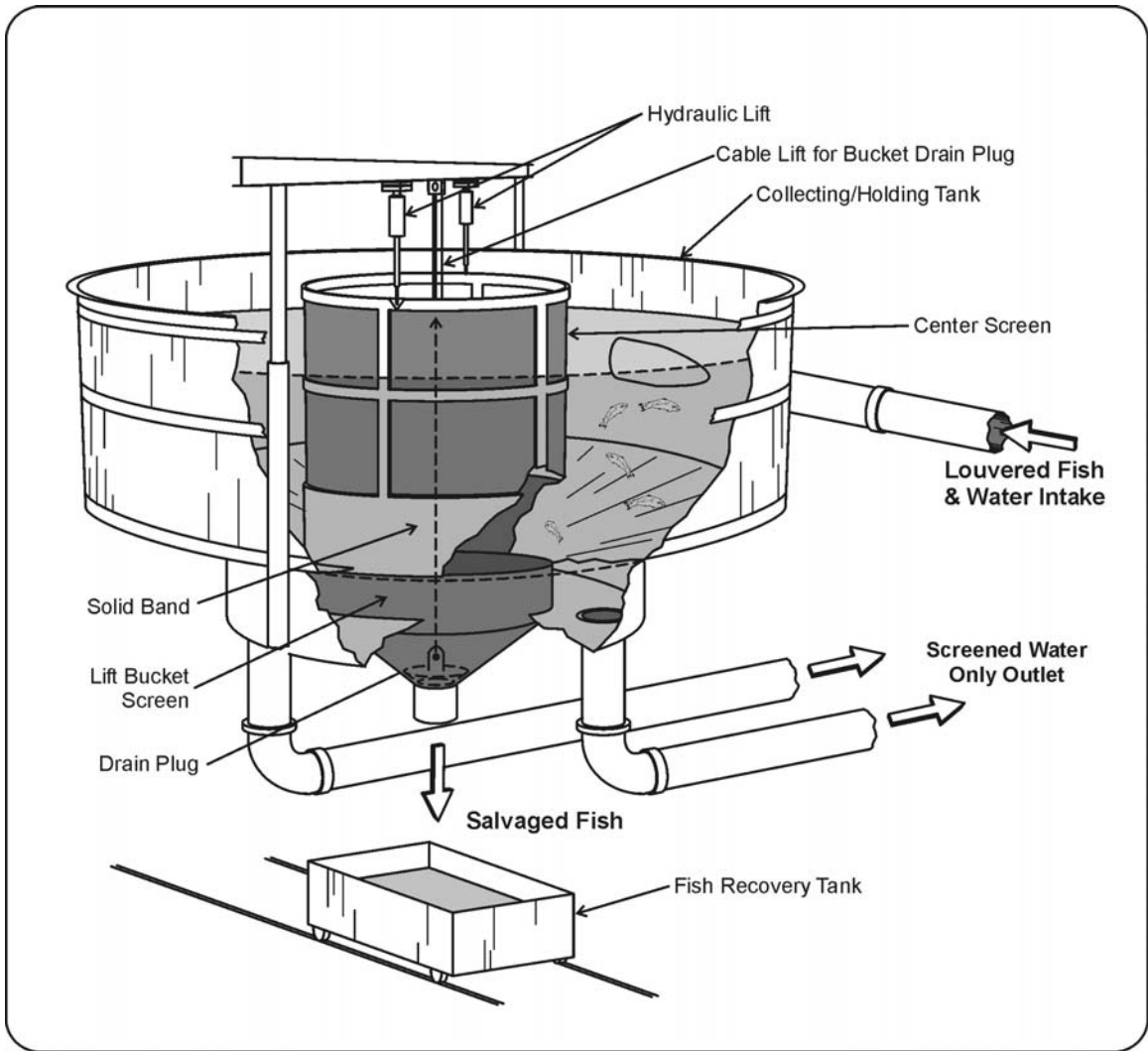

Fig. 3. Cylindrical collecting/holding tank with “lift” bucket fish conveyance method

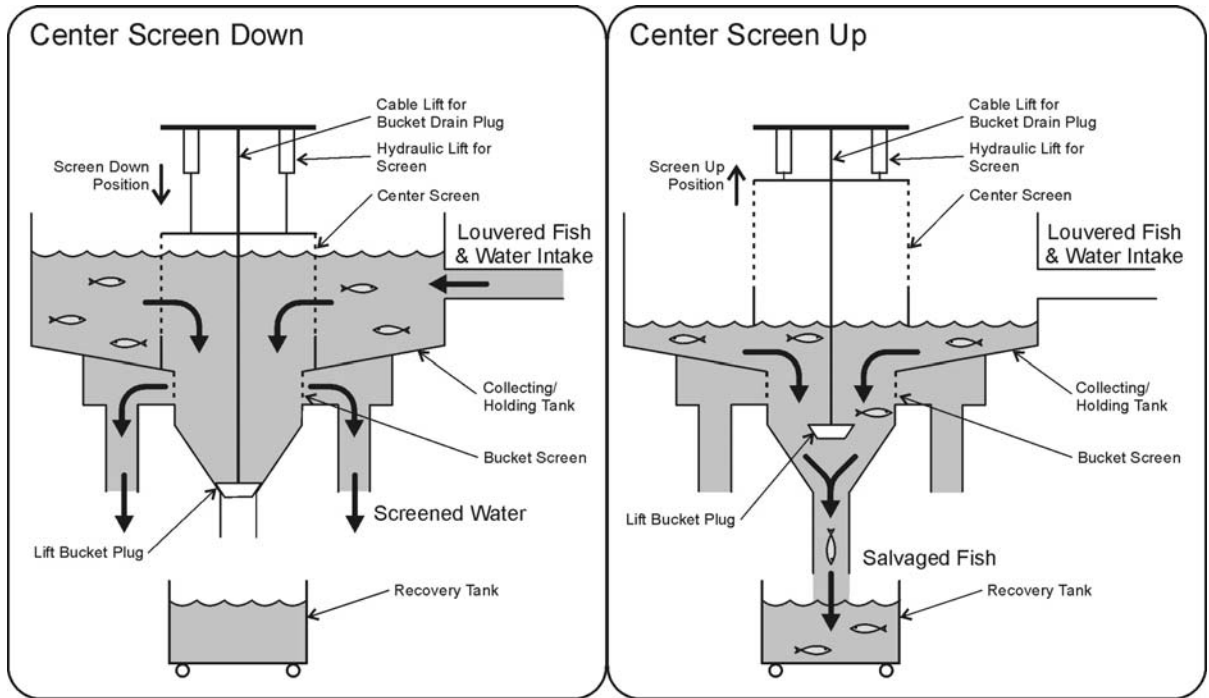

Fig. 4. Draining and fish removal method for the cylindrical collecting/holding tank with “lift” bucket fish conveyance method

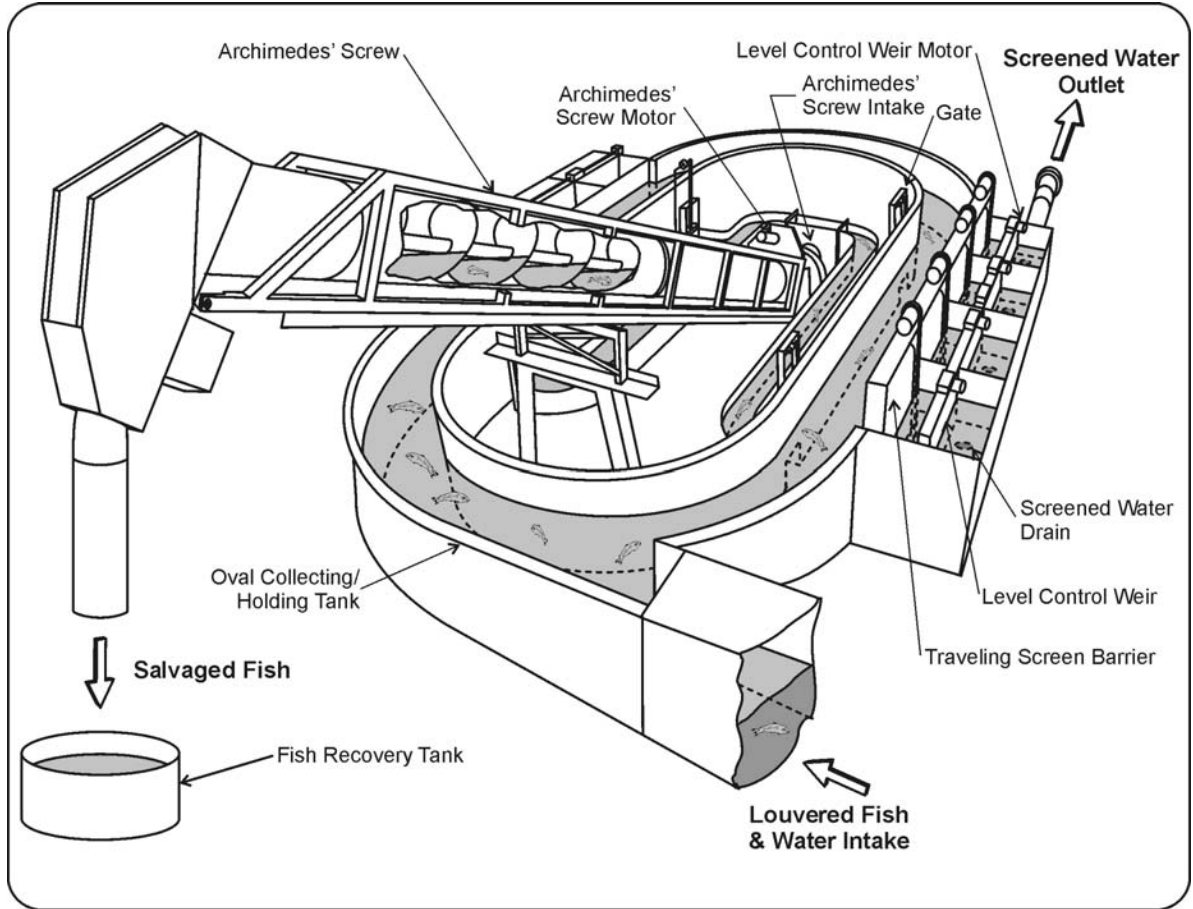

Fig. 5. Oval collecting/holding tank with Pescalator[®] Archimedes-type fish lift.

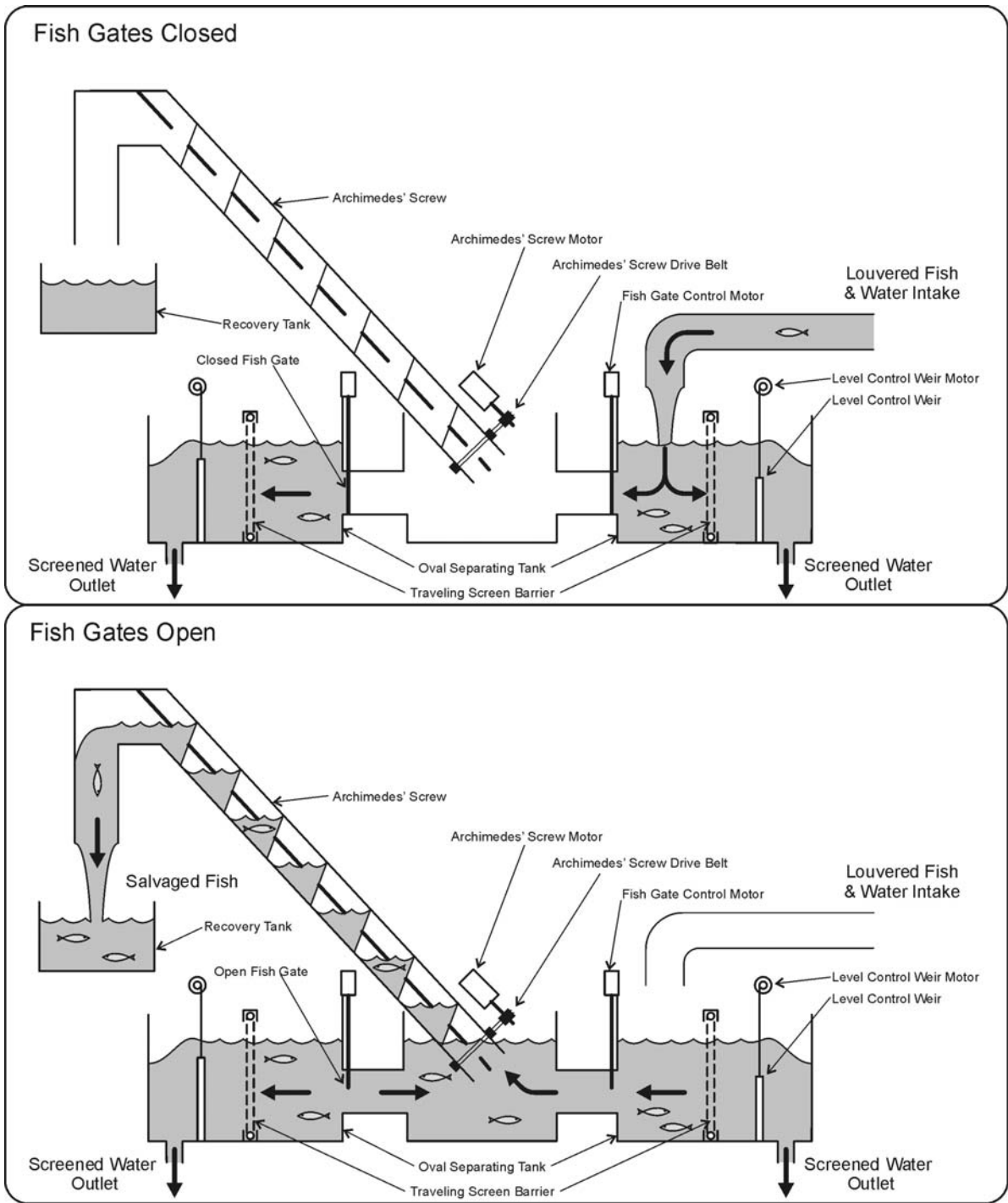

Fig. 6. Draining and fish removal method for the oval collecting/holding tank and Pescalator[®] Archimedes-type lift.

Plasma Cortisol Concentrations

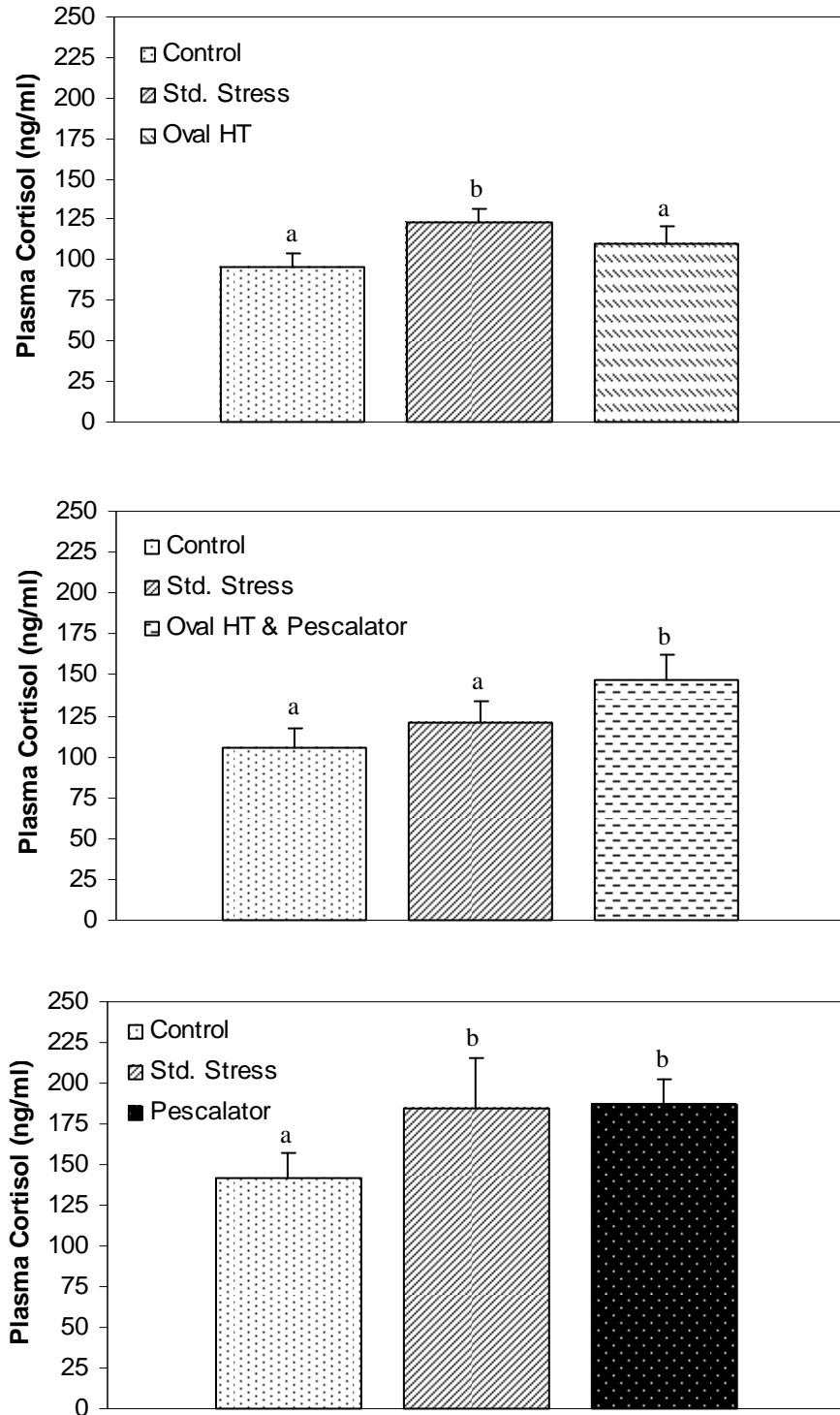

Fig. 7. Plasma cortisol concentrations for the oval holding tank and Pescalator[®] Archimedes-type lift along with corresponding control and standardized stress fish groups. Means are pooled data (± 2 S.E.), $n= 152, 100,$ and $50,$ respectively. Bars with same letter are not statistically different ($P < 0.001$).

Plasma Cortisol Concentrations

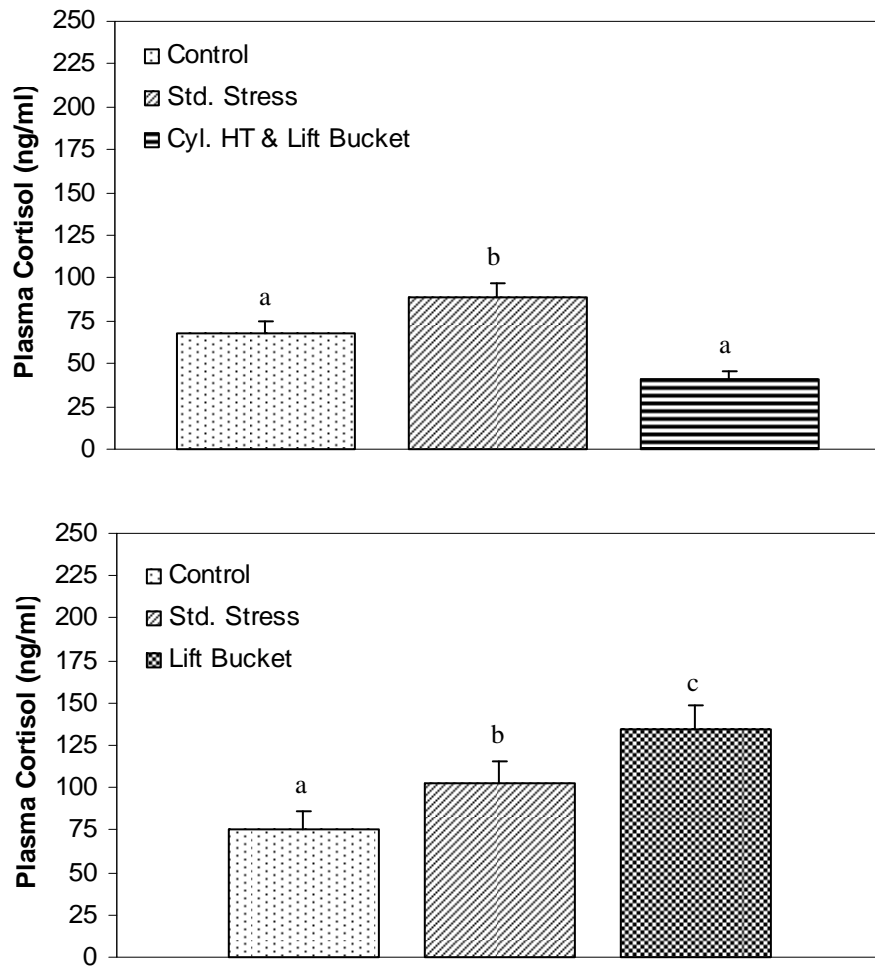

Fig. 8. Plasma cortisol concentrations for the cylindrical holding tank and lift bucket along with corresponding control and standardized stress fish groups. Means are pooled data (± 2 S.E.), $n= 164$ and 48 , respectively. Bars with same letter are not statistically different ($P < 0.001$).

Plasma Glucose Concentrations

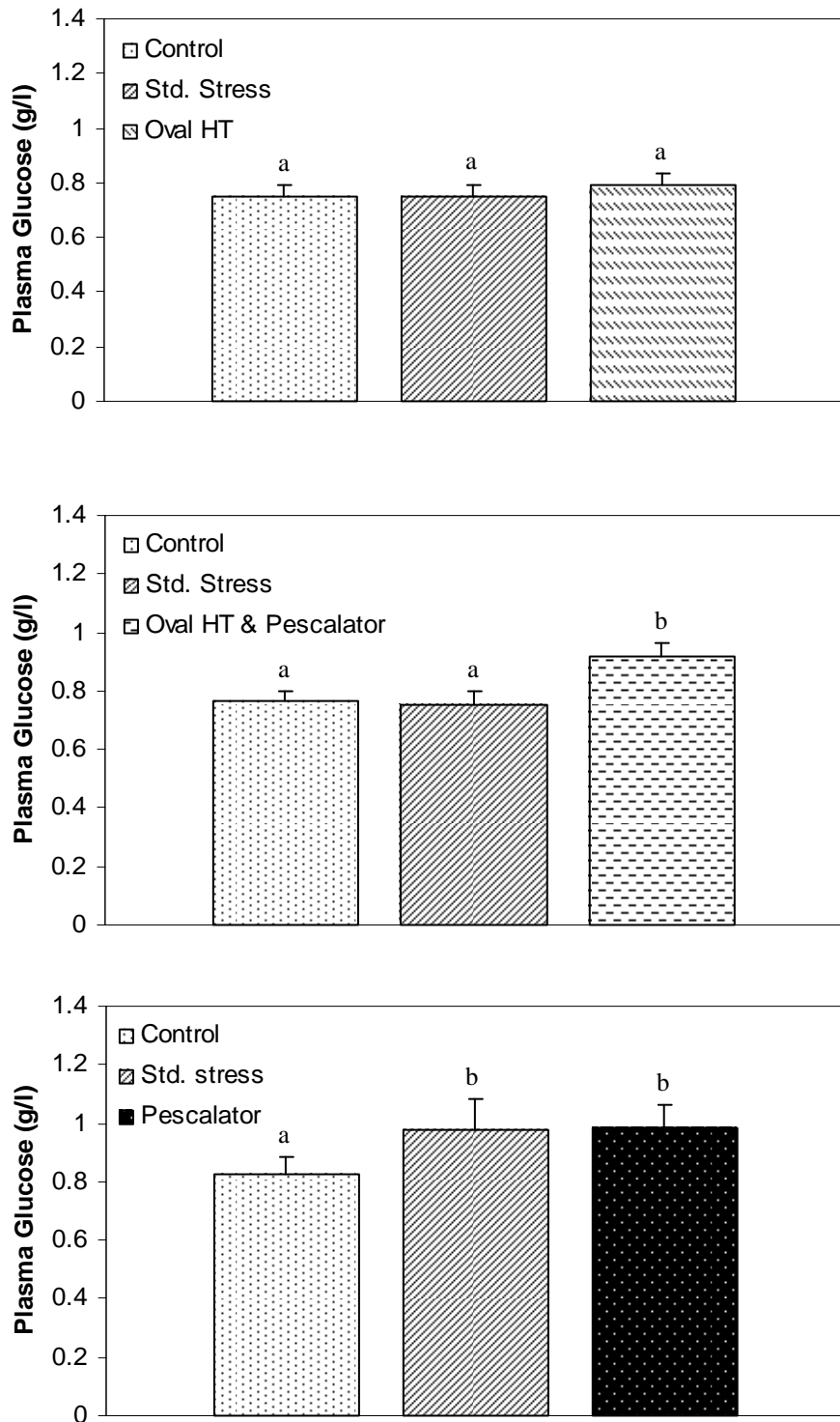

Fig. 9. Plasma glucose concentrations for the oval holding tank and Pescalator[®] Archimedes-type lift along with corresponding control and standardized stress fish groups. Means are pooled data (± 2 S.E.), $n= 152, 100,$ and $50,$ respectively. Bars with same letter are not statistically different ($P < 0.001$).

Plasma Glucose Concentrations

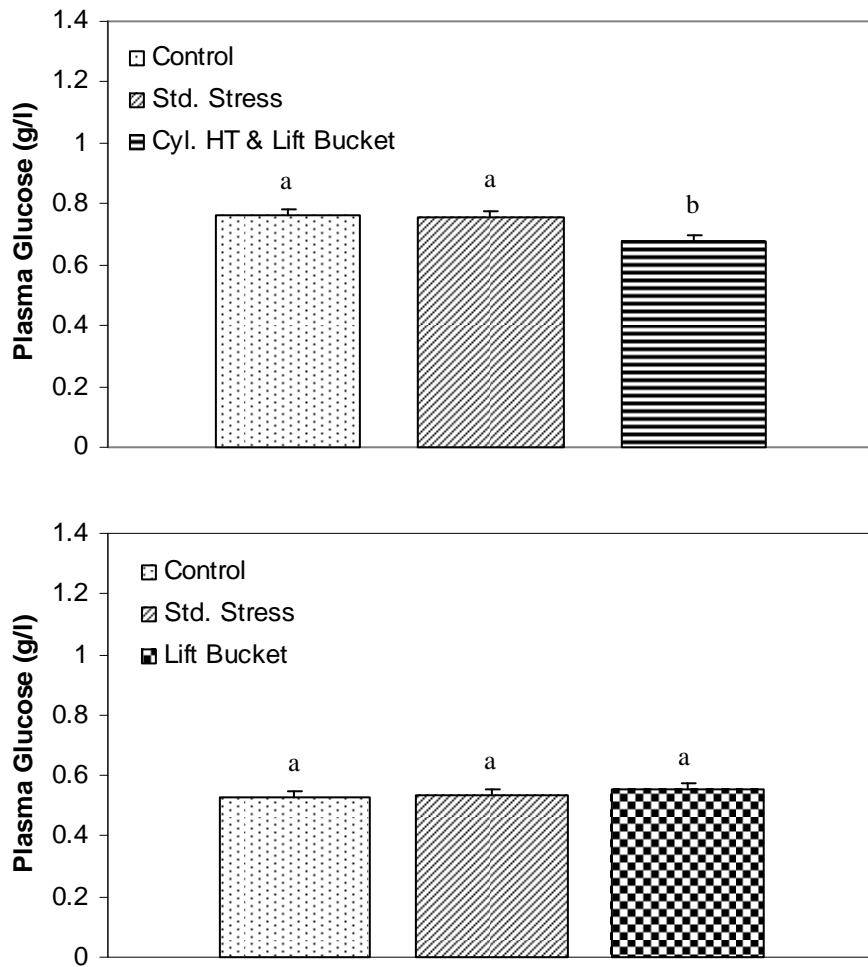

Fig. 10. Plasma glucose concentrations for the cylindrical holding tank and lift bucket along with corresponding control and standardized stress fish groups. Means are pooled data (± 2 S.E.), $n= 164$ and 48 , respectively. Bars with same letter are not statistically different ($P < 0.001$).

Plasma Lactate Concentrations

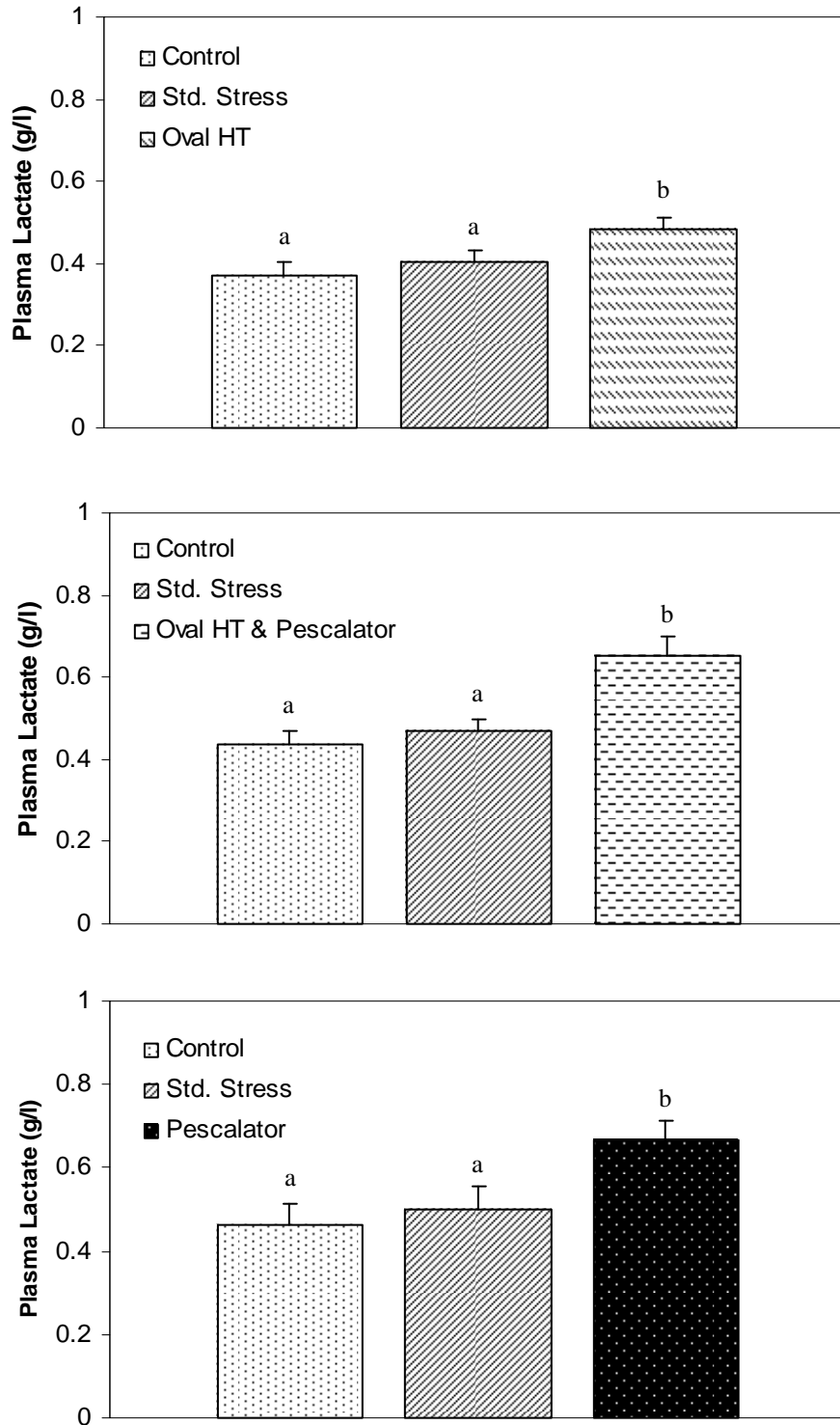

Fig. 11. Plasma lactate concentrations for the oval holding tank and Pescalator[®] Archimedes-type lift along with corresponding control and standardized stress fish groups. Means are pooled data (± 2 S.E.), $n = 152, 100,$ and $50,$ respectively. Bars with same letter are not statistically different ($P < 0.001$).

Plasma Lactate Concentrations

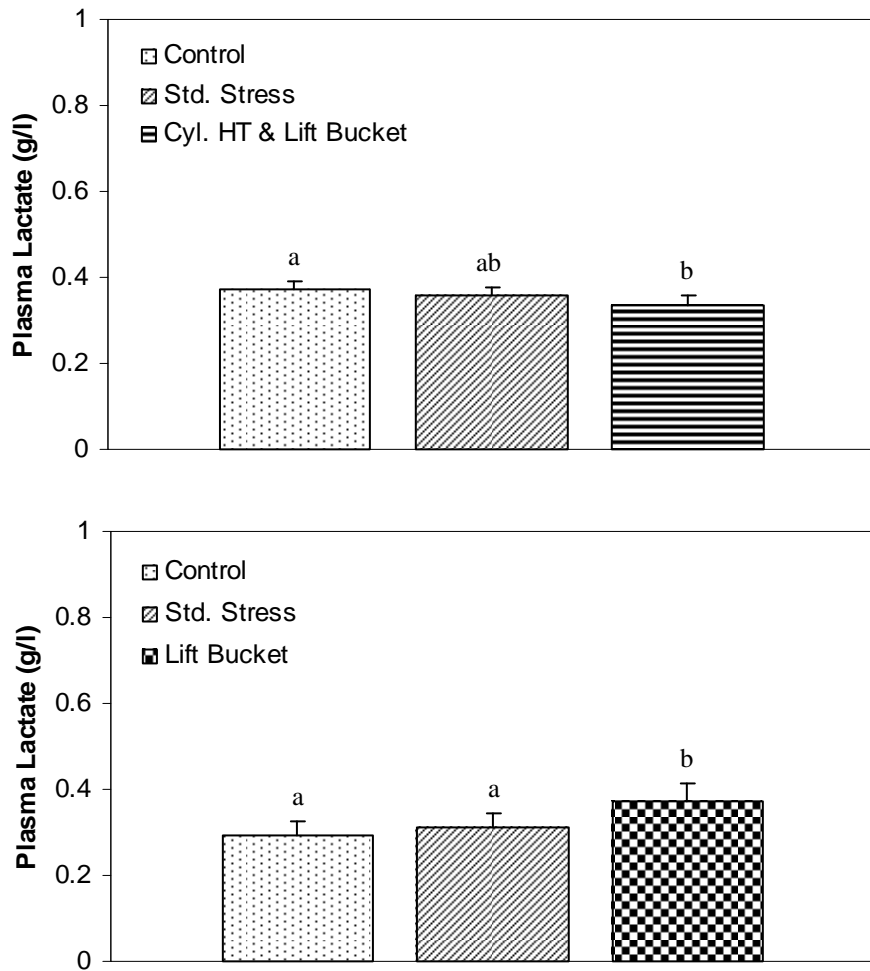

Fig. 12. Plasma lactate concentrations for the cylindrical holding tank and lift bucket along with corresponding control and standardized stress fish groups. Means are pooled data (± 2 S.E.), $n= 164$ and 48 , respectively. Bars with same letter are not statistically different ($P < 0.01$).

Hematocrit Levels

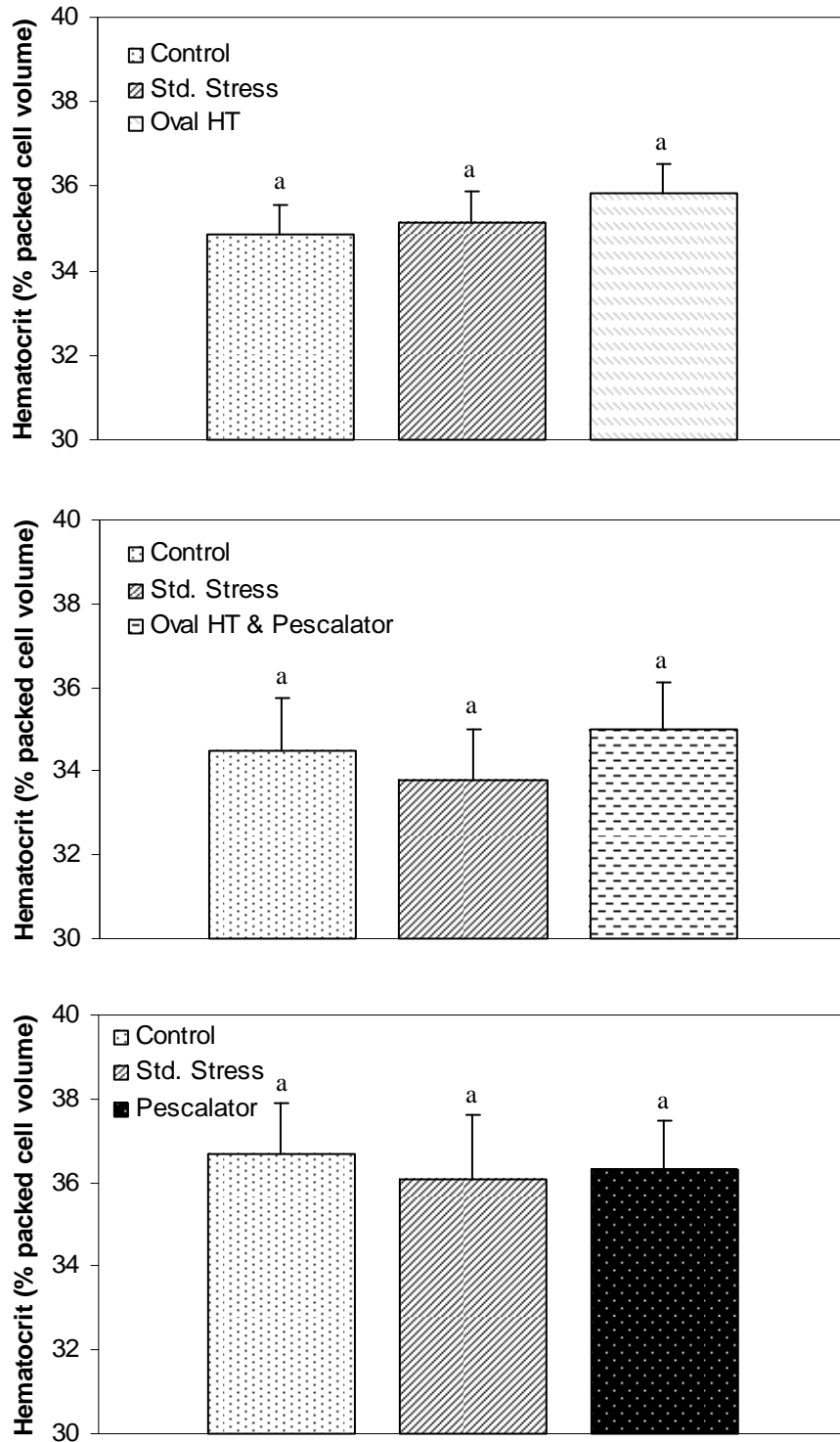

Fig. 13. Hematocrit levels for the oval holding tank and Pescalator[®] Archimedes-type lift along with corresponding control and standardized stress fish groups. Means are pooled data (± 2 S.E.), $n= 152, 100,$ and $50,$ respectively. Bars with same letter are not statistically ($P < 0.001$).

Hematocrit Levels

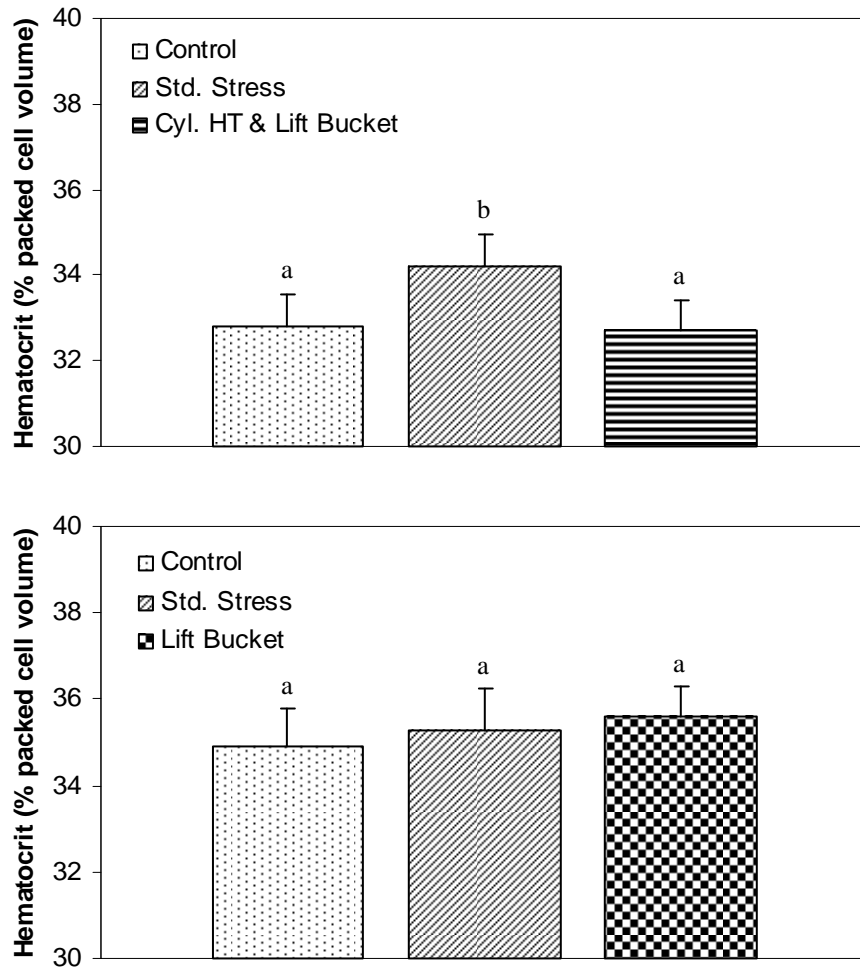

Fig. 14. Hematocrit levels for the cylindrical holding tank and lift bucket along with corresponding control and standardized stress fish groups. Means are pooled data (± 2 S.E.), $n= 164$ and 48 , respectively. Bars with same letter are not statistically ($P < 0.05$).

Osmolalities

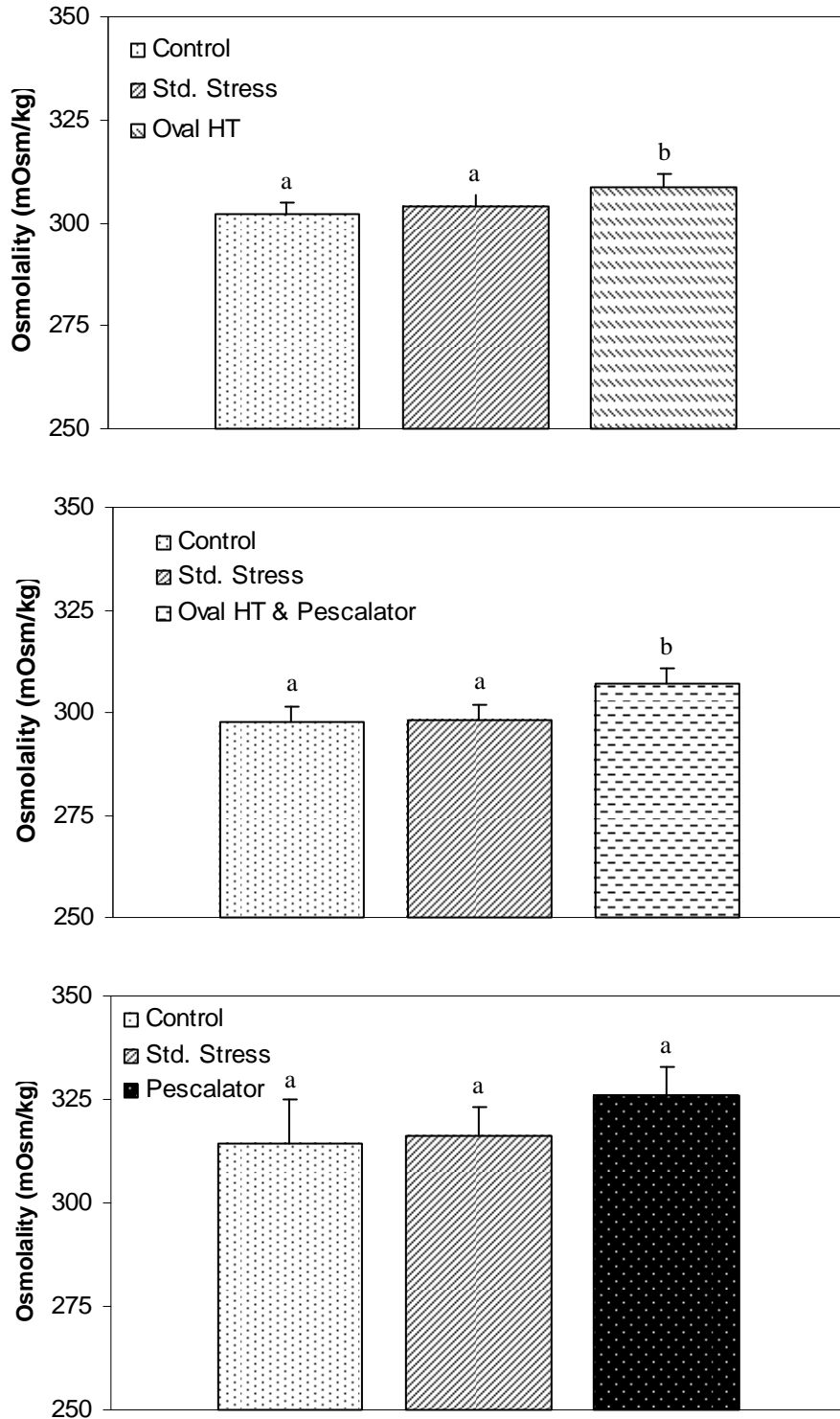

Fig. 15. Osmolalities for the oval holding tank and Pescalator[®] Archimedes-type lift along with corresponding control and standardized stress fish groups. Means are pooled data (± 2 S.E.), $n= 152, 100,$ and $50,$ respectively. Bars with same letter are not statistically ($P < 0.05$).

Osmolalities

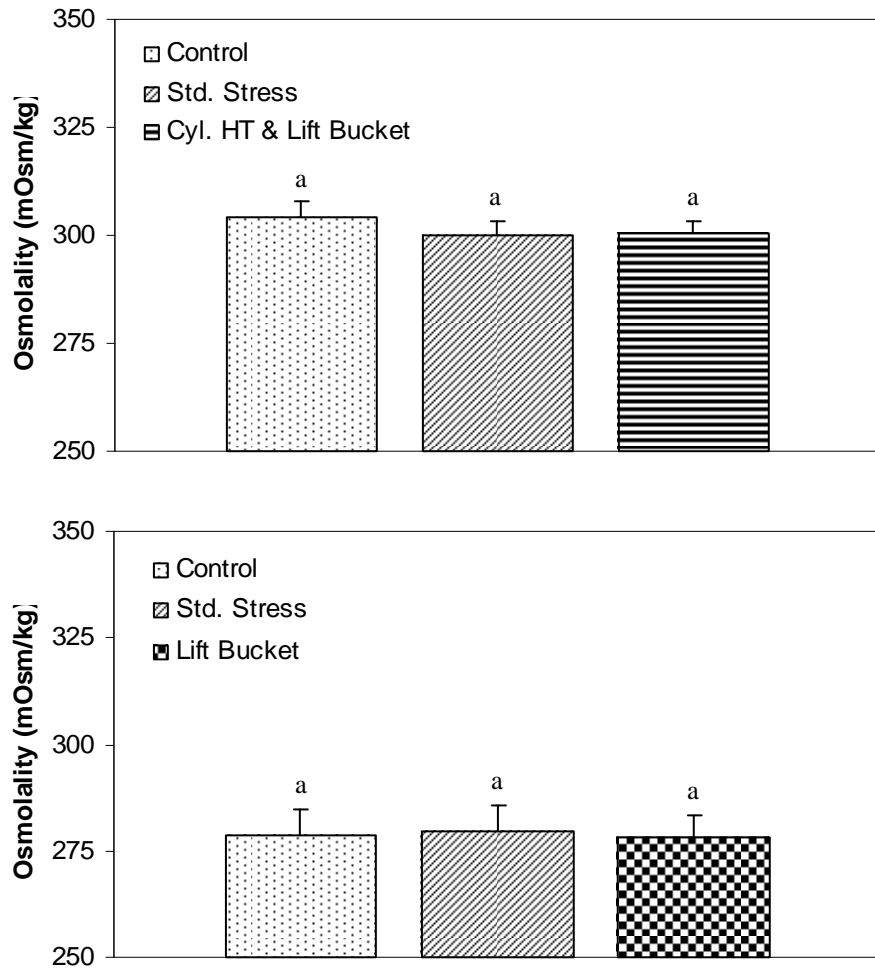

Fig. 16. Osmolalities for the cylindrical holding tank and lift bucket along with corresponding control and standardized stress fish groups. Means are pooled data (± 2 S.E.), $n= 164$ and 48 , respectively. Bars with same letter are not statistically ($P < 0.05$).

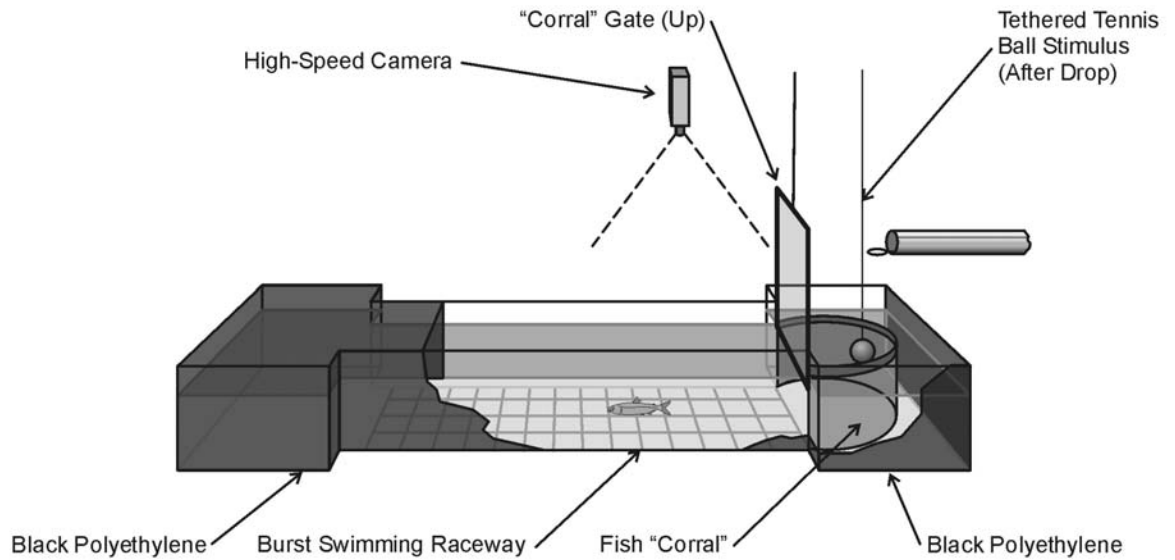

Fig. 17. Burst swimming raceway (220-cm length with a 30-cm wide swimming channel). Raceway bottom was white with a black 1-cm x 1-cm grid to provide scale. Burst swimming speeds and startle responses were filmed at 500 pictures /s. A tethered tennis ball that strikes the water directly behind the fish acted as a stimulus, which ideally elicits a burst response, where in principle the fish swims to the opposite “corral” of the raceway.

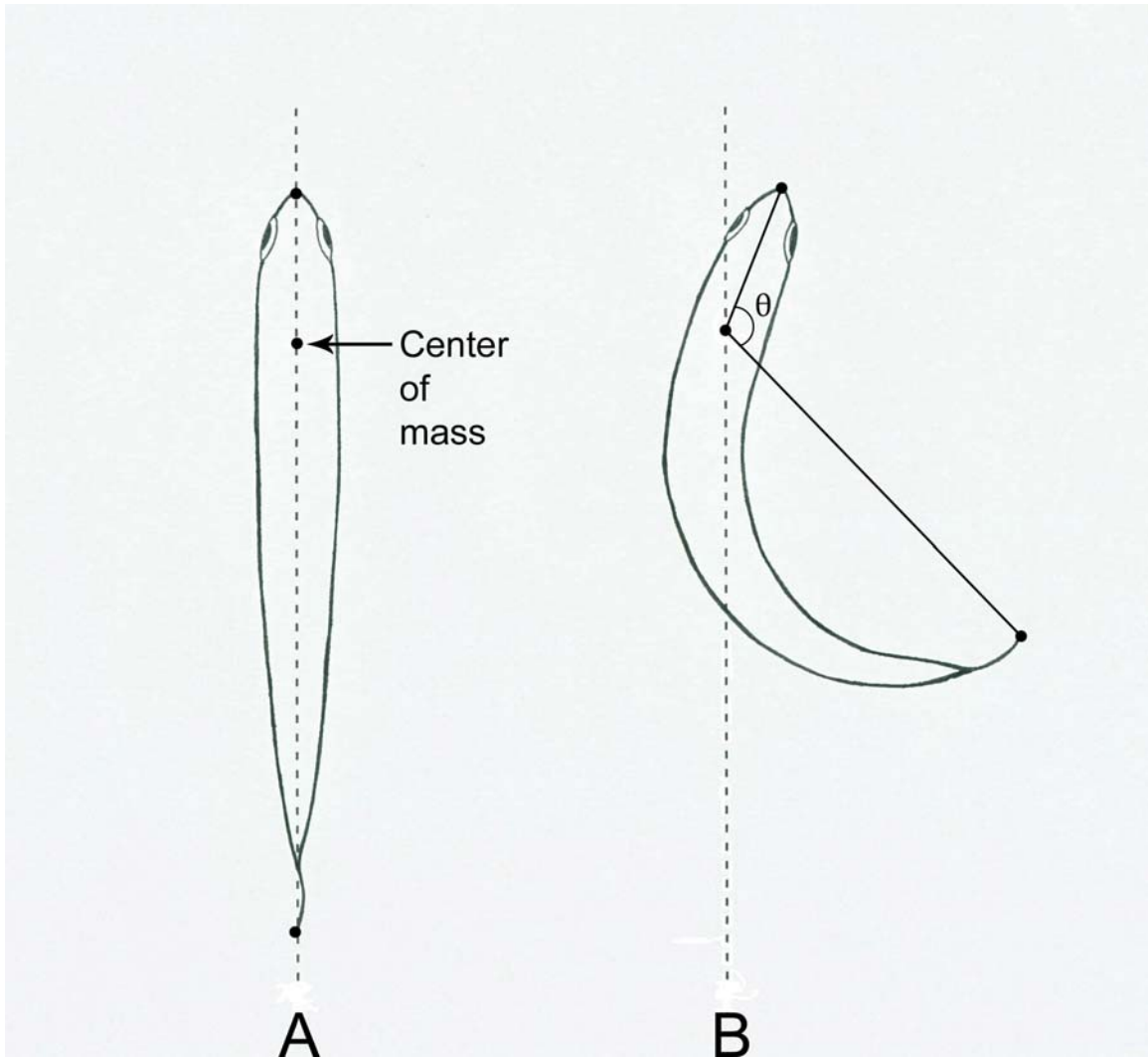

Fig. 18. The startle response in juvenile Chinook salmon (*Oncorhynchus tshawytscha*), (A) at rest and (B) at the preparation stage where the fish bends into a “C” shape. Angle θ is at the center of mass and is made up of a rostrum to center of mass and trailing edge of caudal fin to center of mass. Angle θ is smaller when salmon are bent in a tighter “C” shape.

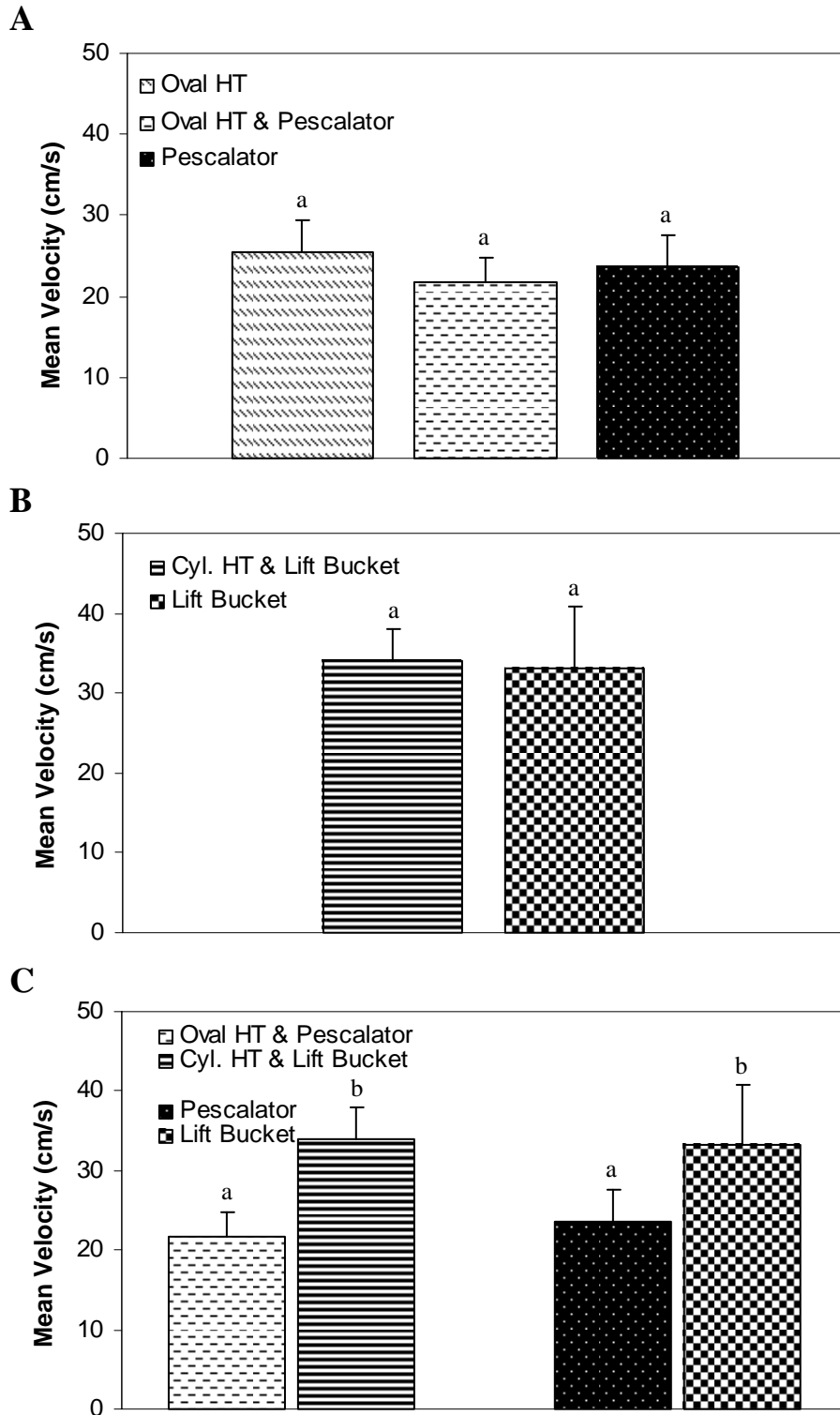

Fig. 19. Mean swimming velocity comparisons for (A & B) within treatment groups and (C) holding tank types with conveyance mechanisms and conveyance mechanisms alone. Means are pooled data (± 2 S.E.). Bars with same letter are not statistically different ($P < 0.05$).

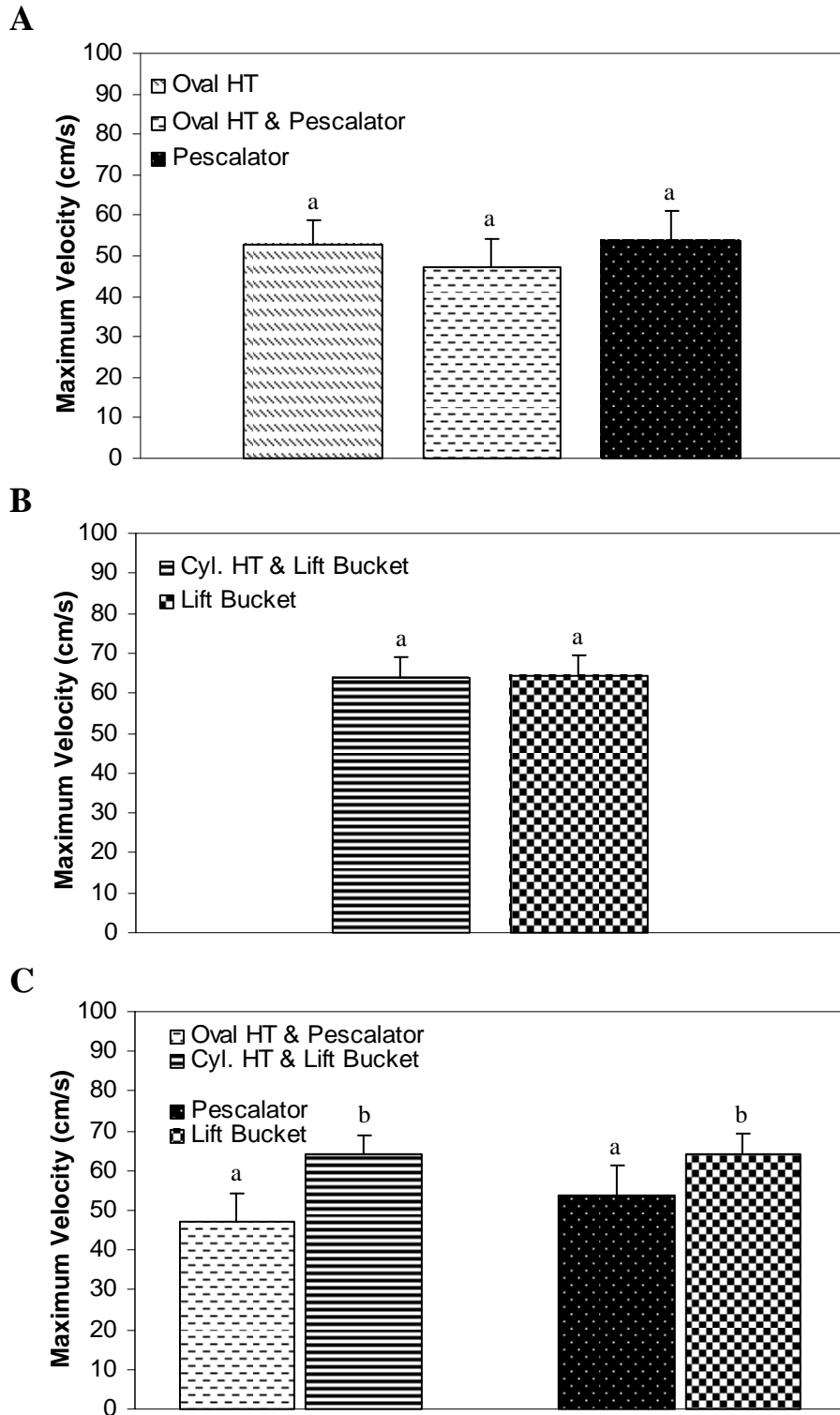

Fig. 20. Maximum swimming velocity comparisons for (A & B) within treatment groups and (C) holding tank types with conveyance mechanisms and conveyance mechanisms alone. Means are pooled data (± 2 S.E.). Bars with same letter are not statistically different ($P < 0.05$).

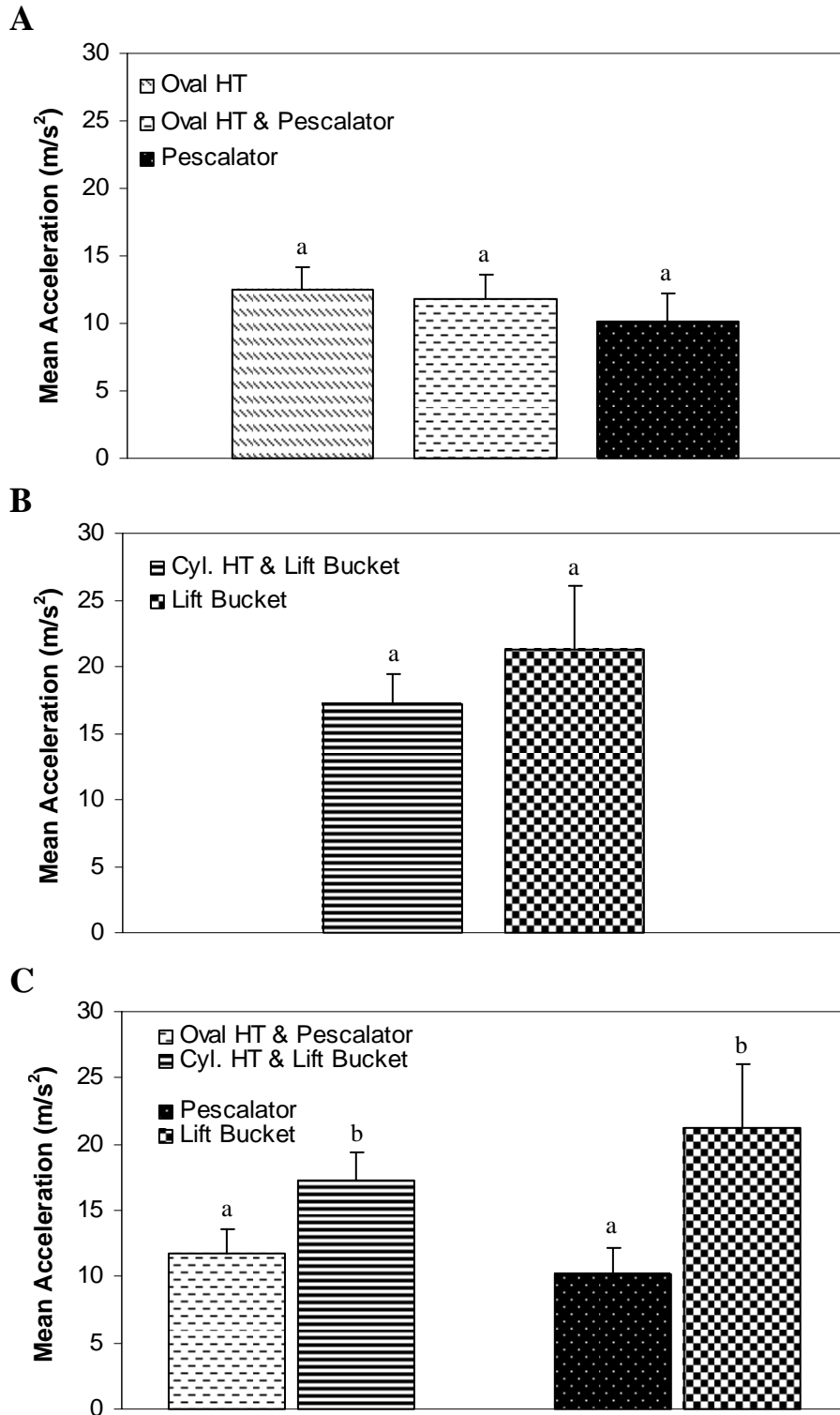

Fig. 21. Mean swimming acceleration comparisons for (A & B) within treatment groups and (C) holding tank types with conveyance mechanisms and conveyance mechanisms alone. Means are pooled data (± 2 S.E.). Bars with same letter are not statistically different ($P < 0.01$).

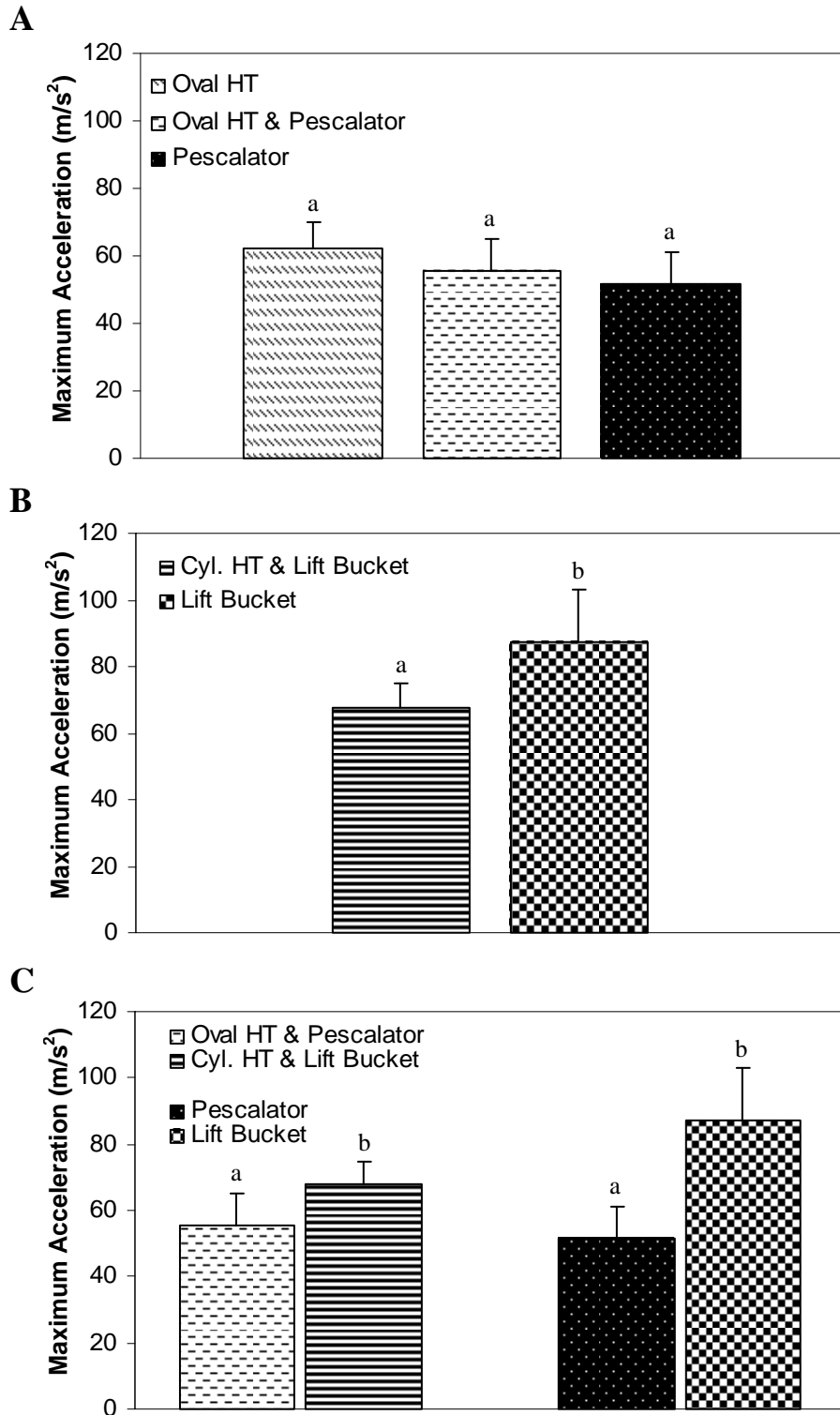

Fig. 22. Maximum swimming acceleration comparisons for (A & B) within treatment groups and (C) holding tank types with conveyance mechanisms and conveyance mechanisms alone. Means are pooled data (± 2 S.E.). Bars with same letter are not statistically different ($P < 0.05$).

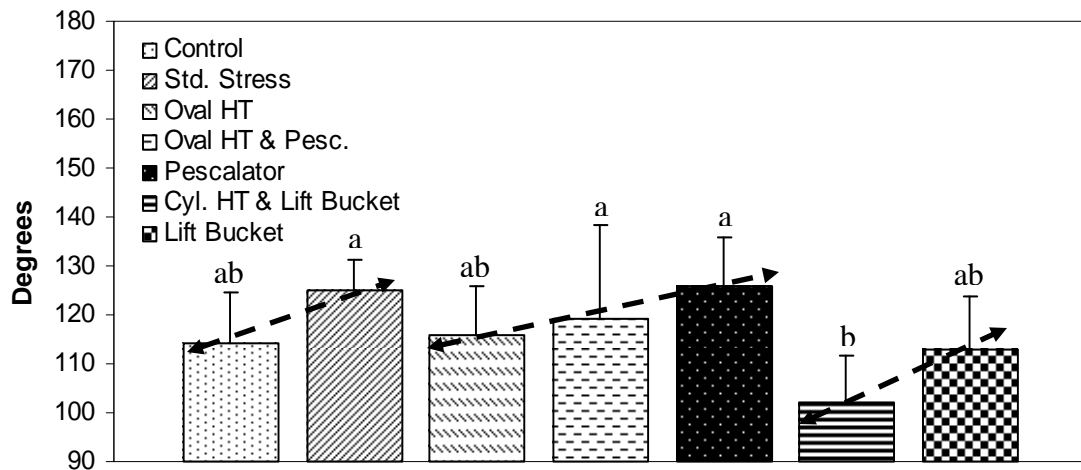

Fig. 23. Maximum C-start angle for juvenile Chinook salmon in response to holding tanks and conveyance methods, control, and standardized stress comparisons. Degrees of bending are smaller when salmon are bent in a tighter “C” shape and 180° when straight (see illustration, Fig. 18). Means \pm 2 S.E.; n= 27, 20, 18, 19, and 18, respectively for control, standardized stress, oval collecting/holding tank, oval collecting/holding tank with Pescalator[®], and Pescalator[®] experiments; and n= 20 and 19 for cylindrical collecting/holding tank with lift bucket, and lift bucket experiments. Only cylindrical collecting/holding tank fish had distinguishable lower C-start phase 1 angles, compared with other treatments ($P < 0.05$). All other treatments are not statistically different. A non-statistical biological trend (3 dashed lines) seems apparent with higher C-start angles (less bending) being associated with more stressful procedures based on plasma constituent analyses from Chapter 2.

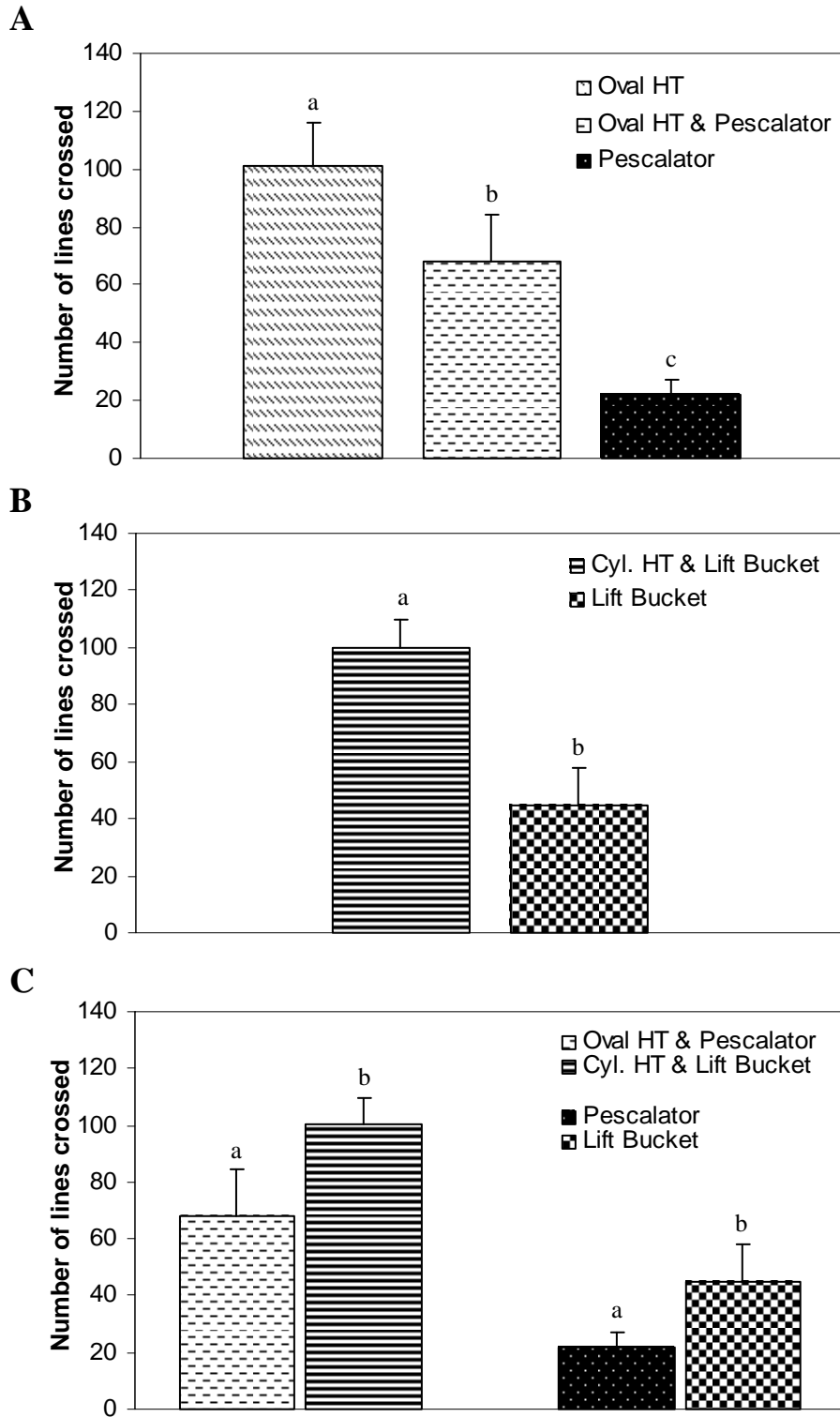

Fig. 24. Maximum swimming performance comparisons from the annular racetrack for (A & B) within treatment groups and (C) holding tank types with conveyance mechanisms and conveyance mechanisms alone. Means are pooled data (± 2 S.E.). Bars with same letter are not statistically different ($P < 0.05$).

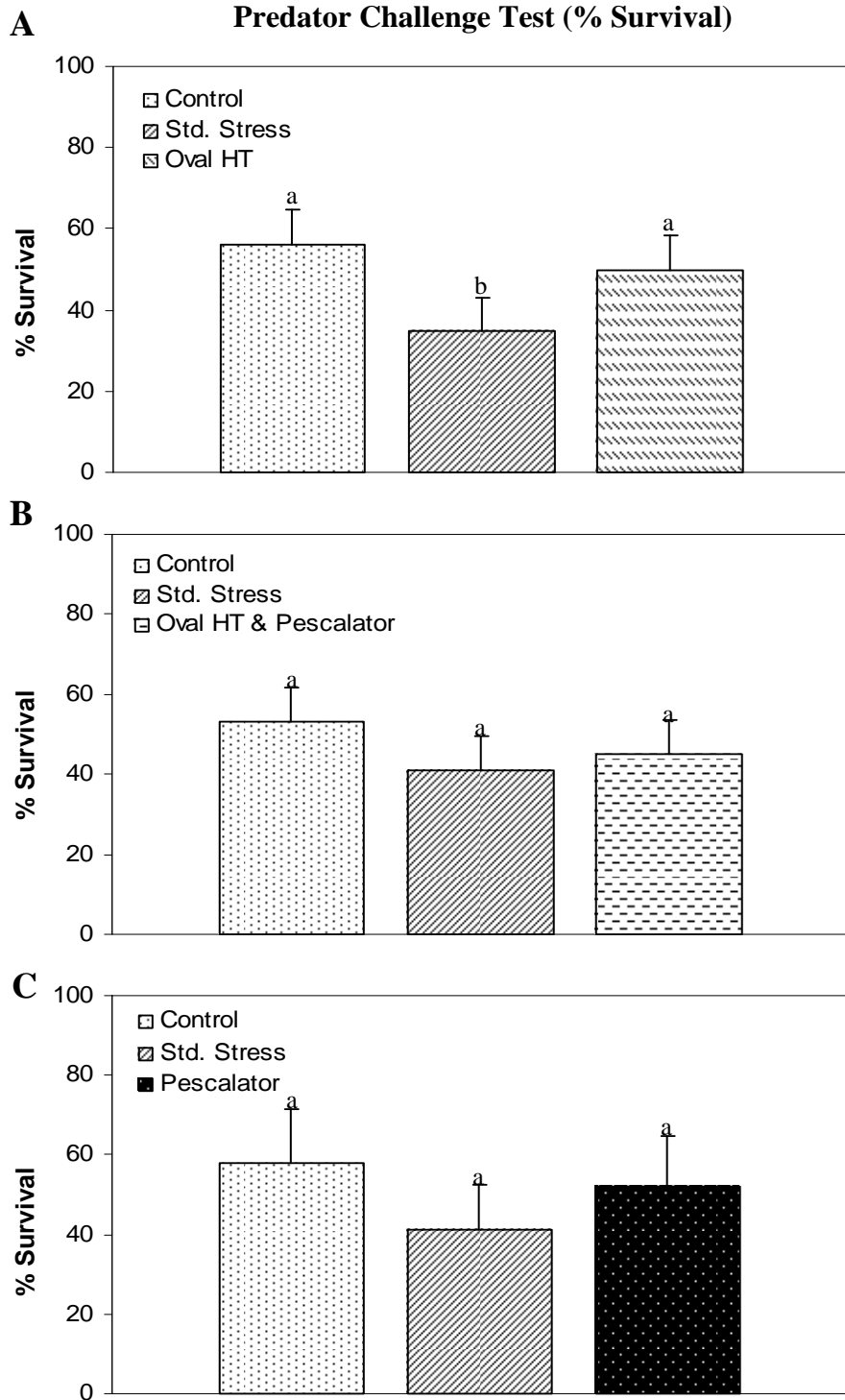

Fig. 25. Percent survival of predation challenge test for oval holding tank alone (A), holding tank with Pescalator[®] Archimedes-type lift (B), Pescalator[®] Archimedes-type lift (alone, C) experiments along with corresponding control and standardized stress fish groups. Means are pooled data (± 2 S.E.), $n= 46$ (A), 54 (B), and 25 (C), respectively. Bars with same letter are not statistically different ($P < 0.05$).

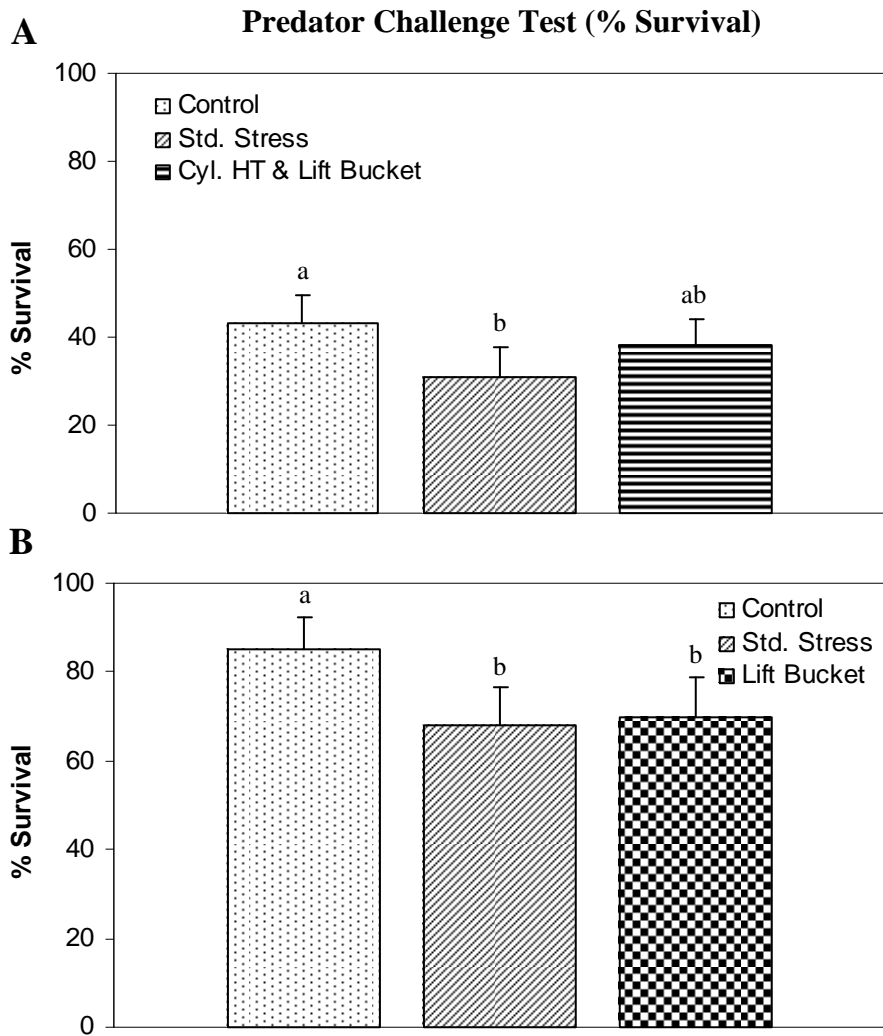

Fig. 26. Percent survival of predation challenge tests for cylindrical holding tank and lift bucket (A), and lift bucket (alone, B) experiments along with corresponding control and standardized stress fish groups. Means are pooled data (± 2 S.E.), $n=77$, and 24 , respectively. Bars with same letter are not statistically different ($P < 0.05$). The findings for lift bucket comparisons should be interpreted cautiously because predators were comparatively untrained early in the experiment.

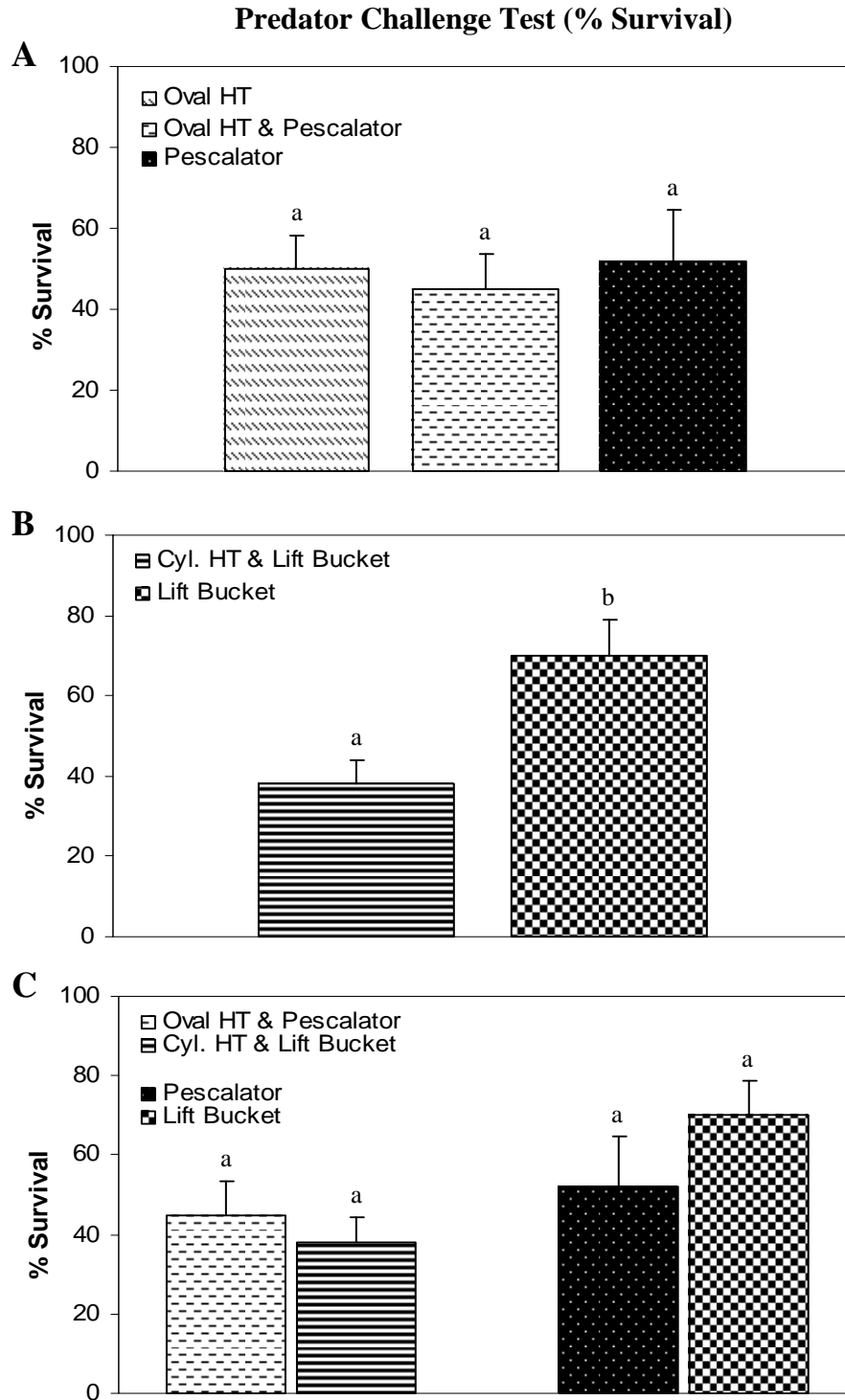

Fig. 27. Percent survival of predation challenge test comparisons for (A & B) within treatment groups and (C) holding tank types with conveyance mechanisms and conveyance mechanisms alone. Means are pooled data (± 2 S.E.). Bars with same letter are not statistically different ($P < 0.05$). Lift Bucket is significantly distinguishable from both oval holding tank with Pescalator[®] and cylindrical holding tank with lift bucket ($P < 0.006$).

Table 1. Hydromineral responses to holding tanks and conveyance methods. Control and standard stress means are pooled data from all comparisons. Means \pm 2 S.E.; n= 302, 302, 152, 100, and 50, respectively for all oval collecting/holding tank associated experiments; and n= 212, 212, 164, and 48 for all cylindrical collecting/holding tank associated experiments. An asterisk (*) denotes a statistical significant difference from the control and a cross (†) denotes a statistical significant difference from the standardized stress group ($P < 0.05$). All hydromineral concentrations are giving in meq/l.

Treatment	Chloride	Sodium	Potassium
<i>Oval collecting/holding tank and Pescalator[®] Archimedes-type lift</i>			
Control	116.7 \pm 3.1	150.0 \pm 3.3	5.5 \pm 0.3
Std. Stress	116.8 \pm 2.6	151.3 \pm 2.7	5.4 \pm 0.3
Oval HT	119.1 \pm 1.7	156.7 \pm 3.1	4.9 \pm 0.3 ^{*†}
Oval HT & Pescalator [®]	117.8 \pm 2.1	148.4 \pm 2.6	4.9 \pm 0.3
Pescalator [®]	117.0 \pm 4.1	152.8 \pm 5.7	6.0 \pm 0.4
<i>Cylindrical collecting/holding tank and lift bucket</i>			
Control	111.7 \pm 2.6	139.1 \pm 3.5	4.5 \pm 0.3
Std. Stress	110.3 \pm 2.4	142.7 \pm 3.5	4.3 \pm 0.3
Cyl. HT & lift bucket	115.5 \pm 2.2	140.8 \pm 3.0	4.3 \pm 0.2
Lift bucket	109.7 \pm 2.3	140.2 \pm 3.5	4.4 \pm 0.2

Table 2. Mean and maximum swimming velocities (cm/s) for juvenile Chinook salmon in response to holding tanks and conveyance methods with control and standardized stress comparisons. Means \pm 2 S.E.; n= 65, 38, and 25, respectively for all oval, oval collecting/holding tank, Pescalator[®] experiments; and n= 71 and 24 for cylindrical collecting/holding tank and lift bucket, and lift bucket experiments. An asterisk (*) denotes a statistical significant difference from the control and a cross (†) denotes a statistical significant difference from the standardized stress group ($P < 0.05$).

Treatment	Mean Velocity (U)	Maximum Velocity (U _{max})
<i>Oval collecting/holding tank and Pescalator[®] Archimedes-type lift</i>		
Control	23.25 \pm 3.21	52.71 \pm 4.97
Std. Stress	19.68 \pm 2.63	47.71 \pm 4.25
Oval HT	25.45 \pm 4.02	52.98 \pm 5.83
Control	27.92 \pm 4.34	56.14 \pm 6.59
Std. Stress	24.65 \pm 3.60	55.81 \pm 5.36
Oval HT & Pescalator [®]	21.79 \pm 3.08	47.37 \pm 6.80
Control	28.80 \pm 5.63	57.07 \pm 6.63
Std. Stress	26.60 \pm 3.57	57.26 \pm 6.03
Pescalator [®]	23.70 \pm 3.84	53.74 \pm 7.51
<i>Cylindrical collecting/holding tank and lift bucket</i>		
Control	32.77 \pm 3.35	58.67 \pm 4.33
Std. Stress	28.29 \pm 3.00	55.88 \pm 3.78
Cyl. HT & lift bucket	34.01 \pm 4.02	64.06 [†] \pm 4.87
Control	34.56 \pm 6.39	60.48 \pm 4.81
Std. Stress	28.73 \pm 4.09	60.15 \pm 5.41
Lift bucket	33.21 \pm 7.56	64.11 \pm 5.29

Table 3. Mean and maximum swimming accelerations (m/s^2) for juvenile Chinook salmon in response to holding tanks and conveyance methods with control and standardized stress comparisons. Means \pm 2 S.E.; n= 65, 38, and 25, respectively for oval collecting/holding tank, oval collecting/holding tank with Pescalator[®], and Pescalator[®] experiments; and n= 71 and 24 for cylindrical collecting/holding tank with lift bucket, and lift bucket experiments. An asterisk (*) denotes a statistical significant difference from the control and a cross (†) denotes a statistical significant difference from the standardized stress group ($P < 0.05$).

Treatment	Mean Acceleration (A)	Maximum Acceleration (A_{max})
<i>Oval collecting/holding tank and Pescalator[®] Archimedes-type lift</i>		
Control	12.87 \pm 1.79	64.97 \pm 9.89
Std. Stress	13.73 \pm 1.67	66.29 \pm 8.64
Oval HT	12.44 \pm 1.66	62.00 \pm 7.90
Control	16.86 \pm 2.66	72.44 \pm 11.79
Std. Stress	15.14 \pm 2.74	68.85 \pm 10.79
Oval HT & Pescalator [®]	11.79* \pm 1.80	55.63 \pm 9.48
Control	14.53 \pm 2.66	75.82 \pm 13.18
Std. Stress	17.63 \pm 2.77	89.36 \pm 17.42
Pescalator [®]	10.20*† \pm 2.03	51.62*† \pm 9.63
<i>Cylindrical collecting/holding tank and lift bucket</i>		
Control	18.01 \pm 2.16	72.78 \pm 8.68
Std. Stress	16.70 \pm 2.56	68.68 \pm 9.92
Cyl. HT & lift bucket	17.22 \pm 2.16	67.87 \pm 6.90
Control	20.06 \pm 3.68	75.39 \pm 12.45
Std. Stress	19.80 \pm 3.01	76.41 \pm 14.53
Lift bucket	21.27 \pm 4.74	86.94 \pm 15.18

Appendix 2

Literature Cited

Adams, S.M. (Ed.). (1990). Biological indicators of stress in fish. American Fisheries Society Symposium 8. Bethesda: American Fisheries Society.

Antelman, S.M., and Caggiula, A.R. (1980). Stress-induced behavior: Chemotherapy without drugs. In J.M. Davidson and R.J. Davidson (eds.), *The Psychobiology of Consciousness* (pp. 65-104). New York: Plenum Press.

Arthur, J.F., Ball, M.D., and Baughman, S.Y. (1996). Summary of the federal and state water project environmental impacts in the San Francisco Bay-Delta Estuary, California. In J.T. Hollibaugh (ed.), *San Francisco Bay: The Ecosystem* (pp. 445-495). San Francisco, CA: American Association for the Advancement of Science, Pacific Division.

Bainbridge, R. (1960). Speed and stamina in three fish. *J. Exp. Biol.* **37**, 129-153.

Barry, T.P., Lapp, A.F., Kayes, T.B., and Malison, J.A. (1993). Validation of a microtitre plate ELISA for measuring cortisol in fish and comparison of stress responses of rainbow trout (*Oncorhynchus mykiss*) and lake trout (*Salvelinus namaycush*). *Aquaculture* **117**, 351-363.

Barry, T.P., Malison, J.A., Held, J.A., and Parrish, J.J. (1995). Ontogeny of the cortisol stress response in larval rainbow trout. *Gen. Comp. Endocrinol.* **97**, 57-65.

Barton, B.A. (2000). Salmonid fishes differ in their cortisol and glucose responses to handling and transport stress. *N. Am. J. Aquacult.* **62**, 12-18.

Barton, B.A. (2002). Stress in fishes: A diversity of responses with particular reference to changes in circulating corticosteroids. *Int. Comp. Biol.* **42**, 517-525.

Barton, B.A., and Schreck, C.B. (1987). Influence of acclimation on temperature on interrenal and carbohydrate stress responses in juvenile Chinook salmon (*Oncorhynchus tshawytscha*). *Aquaculture* **62**, 299-310.

Barton, B.A. and Iwama, G.K. (1991). Physiological changes in fish from stress in aquaculture with emphasis on the response and effects of corticosteroids. *Annu. Rev. Fish. Dis.* **1**, 3-26.

Barton, B.A., Peter, P.E., and Paulencu, C.R. (1980). Plasma cortisol levels of fingerling rainbow trout (*Salmo gairdneri*) at rest, and subjected to handling, confinement, transport, and stocking. *Can. J. Fish. Aquat. Sci.* **37**, 805-811.

Barton, B.A., Schreck, C.B., Ewing, R.D., Hemmingsen, A.R., and Patiño, R. (1985a). Changes in plasma cortisol during stress and smoltification in coho salmon, *Oncorhynchus kisutch*. *Gen. Comp. Endocrinol.* **59**, 468-471.

Barton, B.A., Weiner, G.S., and Schreck, C.B. (1985b). Effect of prior acid exposure on physiological responses of juvenile rainbow trout (*Salmo gairdneri*) to acute handling stress. *Can J Fish Aquat Sci.* **42**, 710-717.

Barton, B.A., Schreck, C.B., and Sigismondi, L.A. (1986). Multiple acute disturbances evoke cumulative physiological responses in juvenile Chinook salmon. *Trans. Am. Fish. Soc.* **115**, 246-251.

Barton, B.A., Bollig, H., Hauskins, and Jansen, C.R. (2000). Juvenile pallid (*Scaphirhynchus albus*) and hybrid pallid x shovelnose (*S. albus x platyrhynchus*) sturgeons exhibit low physiological responses to acute handling and severe confinement. *Comp. Biochem. Physiol. A.* **126**, 125-134.

Barton, B.A., Morgan, J.D. and Vijayan, M.M. (2002). Physiological and condition-related indicators of environmental stress in fish. In Adams, S.M. (ed), *Biological Indicators of Aquatic Ecosystem Stress* (pp. 111-148). Bethesda, MD: American Fisheries Society.

Bates, D.W. and Vinsonhaler, R. (1955). Use of louvers for guiding fish. *Trans. Am. Fish. Soc.* **112**, 38-57.

Batty, R.S. and Baxter, J.H.S. (1992). The effect of temperature on the burst swimming performance of fish larvae. *J. Exp. Biol.* **170**, 187-201.

Beamish, F.W.H. (1978). *Swimming capacity*. In W. Hoar and D. Randall (eds.), *Fish Physiology* (pp. 101-172). New York: Academic Press.

Bennett, W.A. and Moyle, P.B. (1996). Where have all the fishes gone? Interactive factors producing fish declines in the Sacramento-San Joaquin Estuary. In J.T. Hollibaugh (ed), *San Francisco Bay: The Ecosystem* (pp. 519-542). San Francisco: American Association for the Advancement of Science, Pacific Division.

Berejikian, B.A., Tezak, E.P., and LaRae, A.L. (2003). Innate and enhanced predator recognition in hatchery-reared Chinook salmon. *Environ. Bio. Fish.* **67**, 241-251.

Berry, C.R., and Pimentel, R. (1985). Swimming performance of three rare Colorado River fishes. *Trans. Amer. Fish. Soc.* **114**, 397-402.

Boesgaard, L., Nielsen, M.E., and Rosenkilde, P. (1993). Moderate exercise decreases plasma cortisol levels in Atlantic salmon (*Salmo salar*). *Comp. Biochem. Physiol. A.* **106**, 641-643.

Booth, J.H. (1979). The effects of oxygen supply, epinephrine, and acetylcholine on the distribution of blood flow in trout gills. *J. Exp. Biol.* **83**, 31-39.

Boutwell, J.E. and Sisneros, D. (2006). Water Born Debris Removal Evaluations using a Traveling Screen at the Tracy Fish Collection Facility, Tracy, California. *Tracy Fish Collection Facility Studies*, Vol. 33 (45 pp). U.S. Bureau of Reclamation, Mid Pacific Region and Denver Technical Service Center.

Brown, J.A., Johansen, P.H., Colgan, P.W., and Mathers, R.A. (1985). Changes in the predator avoidance behavior of juvenile guppies (*Poecilia reticulata*) exposed to pentachlorophenol. *Can. J. Zool.* **63**, 2001-2005.

Brown, R., Greene, S., Coulston, P., and Barrow, S. (1996). An evaluation of the effectiveness of fish salvage operations at the intake of the California Aqueduct, 1979-1993. In J.T. Hollibaugh (ed), *San Francisco Bay: The Ecosystem* (pp. 497-518). San Francisco: American Association for the Advancement of Science, Pacific Division.

Brown, L.R. and Moyle, P.B. (1993). Distribution, ecology, and status of the fishes of the San Joaquin River Drainage, California. *Calif. Fish Game*, **79**, 96-114.

Cada, G.F., Ryon, M.G., and Wolf, D.A. (2003). Development of a technique to assess susceptibility to predation resulting from sublethal stresses (indirect mortality). U.S. Department of Energy, Oak Ridge National Laboratory, TN.

Cairns, J., Jr. and Van der Schalie, W.H. (1980). Biological monitoring part I: Early warning systems. *Water Res.* **14**, 1179-1196.

Capuzzo, J.M. (1985). Biological effects of petroleum hydrocarbons on marine organisms: Integration of experimental results and predictions of impacts. *Mar. Environ. Res.* **17**, 272-276.

Carey, J.B. and McCormick, S.D. (1998). Atlantic salmon smolts are more responsive to an acute handling and confinement stress than parr. *Aquaculture* **168**, 237-253.

Carmichael, G.J., Wedemeyer, G.A., McCraren, J.P., and Millard J.L. (1983). Physiological effects of handling and hauling stress on smallmouth bass. *Prog. Fish-Cult.* **45**, 110-113.

Carmichael, G.J., Tomasso, J.R., Simco, B.A., and Davis, K.B. (1984). Characterization and alleviation of stress associated with hauling largemouth bass. *Trans. Am. Fish. Soc.* **113**, 778-785.

Carragher, J.F. and Rees, C.M. (1994). Primary and secondary stress responses in golden perch, *Macquaria ambigua*. *Comp. Biochem. Physiol.* **107**, 49-56.

Castro-Santos, T. and Haro, A. (2006). Biomechanics and Fisheries Conservation. In R.E. Shadwick and G.E. Lauder (eds.), *Fish Biomechanics*. (pp. 469-523). New York: Academic Press.

Cech, J.J., Jr. (2000). Osmoregulation in bony fishes. In R.R. Stickney (ed.), *Encyclopedia of Aquaculture* (pp. 614-622). New York: John Wiley and Sons.

Cech, J.J., Jr., Bartholow, S.D., Young, P.S., and Hopkins, T.E. (1996). Striped bass exercise and handling stress in freshwater: physiological responses to recovery environment. *Trans. Am. Fish. Soc.* **125**, 308-320.

Chang, E.Y.-Y. and Liao, I.C. (2003). Sibling cannibalism of the red drum fry. *World Aquac.* **34**, 41-43.

Clearwater, S.J. and Pankhurst, N.W. (1997). The response to capture and confinement stress of plasma cortisol, plasma sex steroids, and vitellogenic oocytes in the marine teleost, red gurnard. *J. Fish Biol.* **50**, 429-441.

Conte, F.S. (2004). Stress and the welfare of cultured fish. *Appl. Anim. Behav. Sci.* **86**, 205-223.

Cooke, S.J., Schreer, J.F., Wahl, D.H., and Philipp, D.P. (2002). Physiological impacts of catch-and-release angling practices on largemouth bass and smallmouth bass. *Proceeding of the American Fisheries Society, Symposium 31*, pp. 489-512.

Coutant, C.C. (1973). Effect of thermal shock on vulnerability of juvenile salmonids to predation. *J. Fish. Res. Bd. Can.* **30**, 965-973.

Danley, M.L., Mayr, S.D., Young, P.S., and Cech, J.J., Jr. (2002). Swimming performance and physiological stress response of splittail exposed to a fish screen *North Am. J. Fish. Manage.* **22**, 541-549.

Davis, M.W. (2005). Behavior impairment in captured and released sablefish: ecological consequences and possible substitute measures for delayed discard mortality. *J. Fish Biol.* **66**, 254-265.

Davis, M.W., and Parker, S.J. (2004). Fish size and exposure to air: potential effects on behavioral impairment and mortality rates in discarded sablefish. *N. Am. J. Fish. Manage.* **24**, 518-524.

Deitinger, T.L. and McCauley, R.W. (1990). Whole animal physiology processes for the assessment of stress in fishes. *J. Great Lakes Res.* **16**, 542-575.

Dettman, D.H. and Kelley, D.W. (1987). The roles of the Feather And Nimbus salmon and steelhead hatcheries and natural reproduction in supporting fall run Chinook salmon populations in the Sacramento River basin. *Report to the California Department of Water Resources, July 1987*. New Castle, California: D.W. Kelley and Associates.

- Domenici, P. and Blake, R.W.** (1997). The kinematics and performance of fish fast-start swimming. *J. Exp. Biol.* **200**, 1165-1178.
- Driedzic, W.R. and Hochachka, P.W.** (1978). Metabolism in fish during exercise. In S. Hoar and D.J. Randall (eds.), *Fish Physiology*, Vol. 7 (pp. 503-543). New York: Academic Press.
- Eaton, R.C., Bombardieri, R.A., and Meyer, D.L.** (1977). The Mauthner-initiated startle response in teleost fish. *J. Exp. Biol.* **66**, 65-81.
- Eaton, R.C., Lavender, W.A., and Wieland, C.M.** (1981). Identification of Mauthner-initiated response patterns in goldfish: evidence from simultaneous cinematography and electrophysiology. *J. Comp. Physiol.* **144**, 521-531.
- Farrell, A.P., Gallaugher, P.E., and Routledge, R.** (2001a). Rapid recovery of exhausted adult coho salmon after commercial capture by troll fishing. *Can. J. Fish. Aquat. Sci.* **58**, 2319-2324.
- Farrell, A.P., Thorarensen, H., Axelsson, M., Crocker, C.E., Gamperl, A.K., and Cech, J J., Jr.** (2001b). Gut blood flow in fish during exercise and severe hypercapnia. *Comp. Biochem. Physiol. A*, **128**, 551-563.
- Fausch, K.** (2000). Reducing Predation Mortality at the Tracy Fish Test Facility: Review and Analysis of Potential Solutions, Vol. 12. *Tracy Fish Collection Facility Studies* (18 pp). U. S. Bureau of Reclamation, Mid Pacific Region, Denver Technical Service Center, and Colorado State University.
- Flagg, T.A., Prentice, E.F., and Smith, L.E.** (1983). Swimming stamina and survival following direct seawater entry during parr-smolt transformation of coho salmon (*Oncorhynchus kisutch*). *Aquaculture* **32**, 383-396.
- Frisch, A.J. and Anderson, T.A.** (2000). The response of coral trout (*Plectropomus leopardus*) to capture, handling and transport and shallow water stress. *Fish Physiol. Biochem.* **23**, 23-34.
- Frith, H.R. and Blake, R.W.** (1995). The mechanical power output and the hydromechanical efficiency of northern pike (*Esox lucius*) fast-starts. *J. Exp. Biol.* **198**, 1863-1873.
- Fuiman, L.A.** (1986). Burst swimming performance of larval zebra danios and the effects of diel temperature fluctuations. *Trans. Am. Fish. Soc.* **115**, 143-148.
- Gadomski, D.M. and Hall-Griswold, J.A.** (1992). Predation by northern squawfish on live and dead juvenile Chinook salmon. *Trans. Am. Fish. Soc.* **121**, 680-685.

Gadomski, D.M., Mesa, M.G., and Olson, T.M. (1994). Vulnerability to predation and physiological stress responses of experimentally descaled juvenile Chinooks salmon, *Oncorhynchus tshawytscha*. *Environ. Bio. Fish.* **39**, 191–199.

Garenc, C., Silversides, F.G., and Guderley, H. (1998). Burst swimming and its enzymatic correlates in the threespine stickleback (*Gasterosteus aculeatus*): full-sib heritabilities. *Can. J. Zool.* **76**, 680-688.

Ghalambor, C.K., Walker, J.A., and Reznick, D.N. (2003). Multi-trait selection, adaptation, and constraints on the evolution of burst swimming performance. *Integr. Comp. Biol.* **43**, 431-438.

Glova, G.J. and McInerney, J.E. (1977). Critical swimming speeds of coho salmon (*Oncorhynchus kisutch*) fry to smolt stages in relation to salinity and temperature. *J Fish Res Board Can* **34**, 151-154.

Greenberg, N., Carr, J.A., and Summers, C.H. (2002). Causes and consequences of stress. *Integr. Comp. Biol.* **42**, 508-516.

Greer-Walker, M. and Pull, G.A. (1975). A survey of red and white muscle in marine fish. *J. Fish Biol.* **7**, 295-300.

Gregory, T.R. and Wood, C.M. (1999). The effects of chronic plasma cortisol elevation on the feeding behaviour, growth, competitive ability, and swimming performance of juvenile rainbow trout. *Physiol and Biochem Zool* **72**, 286-295.

Grutter, A.S. and Pankhurst, N.W. (2000). The effects of capture, handling, confinement and ectoparasite load on plasma levels of cortisol, glucose and lactate in the coral reef fish, *Hemigymnus melapterus*. *J. Fish Biol.* **57**, 391–401.

Handeland, S.O., Järvi, T., Fernö, A., and Stefansson, S.O. (1996). Osmotic stress, antipredator behaviour, and mortality of Atlantic salmon (*Salmo salar*) smolts. *Can. J. Fish. Aquat. Sci.* **53**, 2673-2680.

Haney, D.C., Hursh, D.A., Mix, M.C., and Winton, J.R. (1992). Physiological and hematological changes in chum salmon artificially infected with erythrocytic necrosis virus. *J. Aquat. Anim. Health* **4**, 48-57.

Hatfield, C.T., and Anderson, J.M. (1972). Effects of two insecticides on the vulnerability of Atlantic salmon (*Salmo salar*) parr to brook trout (*Salvelinus fontinalis*) predation. *J. Fish. Res. Bd. Can.* **29**, 27-29.

Hayes, M.C., Focher, S.M., and Contor, C.R. (2000). High pressure injection of photonic paint to mark adult Chinook salmon. *N. Am. J. Aquacult.* **62**, 319-322.

- Heath, A.G., Cech, J.J., Jr., Zinkl, J.G., and Steele, M.D.** (1993a). Sublethal effects of three pesticides on Japanese medaka. *Arch. Environ. Contam. Toxicol.* **25**, 485-491.
- Heath, A.G., Cech, J.J., Jr., Zinkl, J.G., Finlayson, B., and Fujimura, B.** (1993b). Sublethal effects of methyl parathion, carbofuran, and molinate on larval striped bass. *Am. Fish. Soc. Symp.* **14**, 17-28.
- Heath, A.G., Cech, J.J., Jr., Brink, L., Moberg, L.P., and Zinkl, J.G.** (1997). Physiological response of fathead minnow larvae to rice pesticides. *Ecotoxicol. Environ. Saf.* **37**, 280-288.
- Holmgren, S., Axelsson, M., and Farrell A.P.** (1992). The effect of catecholamines, substance P and vasoactive intestinal polypeptide on blood flow to the gut in the dogfish *Squalus acanthias*. *J. exp. Biol.* **168**, 161-175.
- Horak, D.L.** (1972). Survival of hatchery-reared rainbow trout (*Salmo gairdneri*) in relation to stamina tunnel ratings. *J. Fish. Res. Bd. Can.* **29**, 1005-1009.
- Howland, H.C.** (1974). Optimal strategies for predator avoidance: The relative importance of speed and maneuverability. *J. Theor. Biol.* **47**, 333-350.
- Hunter, J.R.** (1972). Swimming and feeding behavior of larval anchovy, *Engraulis mordax*. *Fish. Bull.* **70**, 821-838.
- Iwama, G.K., Morgan, J.D. and Barton, B.A.** (1995). Simple field methods for monitoring stress and general condition of fish. *Aquac. Res.* **26**, 273-282.
- Iwama, G.K., Pickering, A.D., Sumpter, J.P. and Schreck, C.B.** (1997). *Fish stress and health in aquaculture*. Cambridge, UK: Cambridge University Press.
- Jayne, B.C. and Lauder, G.V.** (1993). Red and white muscle activity and kinematics of the escape response of the bluegill sunfish during swimming. *J. Comp. Physiol. A* **173**, 495-508.
- Jensen, F.B.** (1991). Multiple strategies in oxygen and carbon dioxide transport by hemoglobin. In A.J. Woakes, M.K. Grieshaber, and C.R. Bridges (eds.), *Physiological Strategies for Gas Exchange and Metabolism* (pp.55-78). Cambridge, UK: Cambridge University Press.
- Kania, H.J., and O'Hara, J.** (1974). Behavioral alterations on a simple predator-prey system due to sublethal exposure to mercury. *Trans. Am. Fish. Soc.* **103**, 134-136.
- Karp, C. and Lyons, J.** (2007). Fish Holding Evaluation at the Tracy Fish Collection Facility. *Tracy Fish Collection Facility Studies*, Vol. 37 (17 pp). U.S. Bureau of Reclamation, Mid-Pacific Region and Denver Technical Service Center.

Kimmerer, W. and Brown, R. (Eds.). (2006). A Summary of the June 22 -23, 2005 Predation Workshop, Including the Expert Panel Final Report . *Proceedings of the CALFED Bay-Delta Program's Science Program and California Department of Water Resource Predation Workshop*. Romberg, Tiburon Center for Environmental Studies, Tiburon CA 22-23 June 2005, pp. 38.

Kubitza, F. and Lovshin, L.L. (1999). Formulated diets, feeding strategies, and cannibalism control during intensive culture of juvenile carnivorous fishes. *Crit. Rev. Fish. Sci.* **7**, 1–22.

Lankford, S.E., Adams, T.E., and Cech, J.J., Jr. (2003). Time of day and water temperature modify the physiological stress response in green sturgeon, *Acipenser medirostris*. *Comp. Biochem. Physiol. A*, **135**, 291–302.

Lankford, S.E., Adams, T.E., Miller, R.A., and Cech, J.J., Jr. (2005). The cost of chronic stress: Impacts of a nonhabituating stress response on metabolic variables and swimming performance in sturgeon. *Physiol. Biochem. Zool.* **78**, 599-609.

Liston, C., Karp, C., Hess, L., and Hiebert, S. (1994). Predator Removal Activities and Intake Channel Studies, 1991-1992. *Tracy Fish Collection Facility Studies*, Vol.1 (pp. 54). U. S. Bureau of Reclamation, Mid-Pacific Region and Denver Technical Service Center.

Liston, C.R., Christensen, R., Mefford, B., Glickman, A., and Johnson, P. (2000). *Feasibility Report Number 2: A proposed technology development facility to support improvement and/or replacement of fish salvage facilities at Tracy and other large fish screening sites in the Sacramento-San Joaquin Delta, California*. Bureau of Reclamation, Denver Technical Service Center and Mid-Pacific Region, Denver, CO, and Sacramento, CA.

Little, E.E., Archeski, R.D., Flerov, B.A., Kozlovskaya, V.I. (1990). Behavioral indicators of sublethal toxicity in rainbow trout. *Arch. Environ. Contam. Toxicol.* **19**, 380-385.

Losey, G.S., Cronin, T.W., Goldsmith, T.H., Hyde, D., Marshall, N.J., and McFarland, W.N. (1999). The UV visual world of fishes: a review. *J. Fish Biol.* **54**, 921-943.

Love, R.M. (1970). *The Chemical Biology of Fishes*, Vol. 1. New York: Academic Press.

Lowe, T.E. and Wells, M.G. (1996). Primary and secondary stress responses to line capture in the blue mao mao. *J. Fish Biol.* **49**, 287-300.

Marine, K.R., and Cech, J.J., Jr. (2004). Effects of high water temperatures on growth, smoltification, and predator avoidance in juvenile Sacramento River Chinook Salmon. *N. Am. J. Fish. Manage.* **24**, 198-210.

Martinelli, T.L., Hansel, H.C., and Shively, R.S. (1998). Growth and physiological responses to surgical and gastric radio transmitter implantation techniques in subyearling Chinook salmon (*Oncorhynchus tshawytscha*). *Hydrobiologia* **371/372**, 79-87.

Maule, A.G., Schreck, C.B., Bradford, C.S., and Barton, B.A. (1988). Physiological effects of collecting and transporting emigrating juvenile Chinook salmon past dams on the Columbia River. *Trans. Am. Fish. Soc.* **117**, 245-261.

Maule, A.G., Schreck, C.B., and Sharpe, C. (1993). Seasonal changes in cortisol sensitivity and glucocorticoid receptor affinity and number in leukocytes of coho salmon. *Fish Physiol. Biochem.* **10**, 497-506.

Mazeaud, M.M., Mazeaud, F., and Donaldson, E.M. (1977). Primary and secondary effects of stress in fish: Some new data with a general review. *Trans. Am. Fish. Soc.* **106**, 201-212.

Mazeaud, M.M. and Mazeaud, F. (1981). Adrenergic responses to stress in fish. In A.D. Pickering (ed.), *Stress and Fish* (pp. 49-75). New York: Academic Press.

McNabb, C.D., Liston, C.R., and Borthwick, S.M. (2003). Passage of juvenile Chinook salmon and other fish species through Archimedes lifts and a Hidrostal pump at Red Bluff, California. *Trans. Am. Fish. Soc.* **132**, 326-334.

Mesa, M.G. (1994). Effects of multiple acute stressors on the predator avoidance ability and physiology of juvenile Chinook salmon. *Trans. Am. Fish. Soc.* **123**, 786-793.

Mesa, M.G., and Warren, J.J. (1997). Predator avoidance ability of juvenile Chinook salmon (*Oncorhynchus tshawytscha*) subjected to sublethal exposures of gas-supersaturation water. *Can. J. Fish. Aquat. Sci.* **54**, 757-764.

Mesa, M.G., Poe, T.P., Gadomski, D.M., and Petersen, J.H. (1994). Are all prey created equal? A review and synthesis of differential predation on prey in substandard condition. *J. Fish Biol.* **45**, 81-96.

Mesa, M.G., Poe, T.P., Maule, A.G., Schreck, C.B. (1998). Vulnerability to predation and physiological stress response in juvenile Chinook salmon (*Oncorhynchus tshawytscha*) experimentally infected with *Renibacterium salmoninarum*. *Can. J. Fish. Aquat. Sci.* **55**, 1599-1606.

- Meyer, W.F. and Cook, P.A.** (1996). An assessment of the use of low-level aerobic swimming in the promoting recovery from handling stress in rainbow trout. *Aquacult. Int.* **4**, 169-174.
- Milligan, C.L.** (1996). Metabolic recovery from exhaustive exercise in rainbow trout. *Comp. Biochem. Physiol. A*, **113**, 51-60.
- Milligan, C.L. and Farrell, A.P.** (1991). Lactate utilization by an *in situ* perfused trout heart: Effects of workload and blockers of lactate transport. *J. Exp. Biol.* **155**, 357-373.
- Milligan, C.L. and McDonald, G.** (1988). In vitro lactate kinetics at rest and during recovery from exhaustive exercise in coho salmon (*Oncorhynchus kisutch*) and starry flounder (*Platichthys stellatus*). *J. Exp. Biol.* **135**, 119-131.
- Milligan, C.L., Hooke, G.B., and Johnson, C.** (2000). Sustained swimming at low velocity following a bout of exhaustive exercise enhances metabolic recovery in rainbow trout. *J. Exp. Biol.* **203**, 921-926.
- Mitchell, M.D.** (1996). The Sacramento-San Joaquin Delta, California: initial transformation into a water supply and conveyance node, 1900- 1955. *J. West.* **35**, 44-53.
- Mommsen, T.P., Vijayan, M.M., and Moon, T.W.** (1999). Cortisol in teleosts: Dynamics, mechanisms of action, and metabolic regulation. *Rev. Fish Biol. Fish.* **9**, 211-268.
- Montero, D., Izquierdo, M.S., Tort, L., Roaina, L., and Vergara, J.M.** (1999). High stocking density produces crowding stress altering some physiological and biochemical parameters in gilthead seabream, *Sparus aurata*, juveniles. *Fish Physiol. Biochem.* **20**, 53-60.
- Moyle, P.B.** (2002). *Inland fishes of California*. Berkley, CA: University of California Press.
- Moyle, P.B. and Cech, J.J., Jr.** (2004). *Fishes: An Introduction to Ichthyology* (5th ed.). New Jersey: Prentice Hall.
- Munro, C. and Stabenfeldt, G.** (1984). Development of a microtiter plate enzyme immunoassay for the determination of progesterone. *J. Endocr.* **101**, 41-49.
- Munro, C. and Stabenfeldt, G.** (1985). Development of a cortisol enzyme immunoassay in plasma. *Clin. Chem.* **31**, 956.
- Myers, J.M., Kope, R.G., Bryant, G.J., Teel, D., Lierheimer, L.J., Wainwright, T.C., Grant, W.S., Waknitz, F.W., Neely, K., Lindley, S.T., and Waples, R.S.** (1998). Status review of Chinook salmon from Washington, Idaho, Oregon, and California.

NOAA Technical Memorandum NMFS-NWFSC-35, February 1998. Seattle: National Marine Fisheries Service.

Nikinmaa, M., Cech, J.J. Jr., and McEnroe, M. (1984). Blood oxygen transport in stressed striped bass (*Morone saxatilis*): Role of beta-adrenergic responses. *J. Comp. Physiol., B.* **154**, 365-369.

Nikinmaa, M. (1986). Red cell pH of Lamprey (*Lampetra fluviatilis*) is actively regulated. *J. Comp. Physiol., B.* **156**, 747-750.

OCAP Biological Opinion (2005). Operating Criteria and Plan for the Central Valley Project (CVP) and the State Water Project (SWP). (No. 1-1-05-F-0055). U.S. Fish and Wildlife Service.

Olla, B.L. and Davis, M.W. (1989). The role of learning and stress in predator avoidance of hatchery reared coho salmon (*Oncorhynchus kisutch*) juveniles. *Aquaculture* **76**, 209-214.

Olla, B.L., Davis, M.W., and Schreck, C.B. (1992). Comparison of predator avoidance capabilities with corticosteroid levels induced by stress in juvenile coho salmon. *Trans. Am. Fish. Soc.* **121**, 544-547.

Olla, D.L., Davis, M.W., and Schreck, C.B. (1995). Stress-induced impairment of predator evasion and non-predator mortality in Pacific salmon. *Aquac. Res.* **26**, 393-398.

Ortuño, J., Esteban, M.A., and Meseguer, J. (2001). Effects of short-term crowding stress on the gilthead seabream (*Sparus aurata L.*) innate immune response. *Fish Shellfish Immunol.* **11**, 187-197.

Pankhurst, N.W. and Sharples, D.F. (1992). Effects of capture and confinement on plasma cortisol concentrations in the snapper, *Pagrus auratus*. *Aust. J. Mar. Freshw. Res.* **43**, 345-356.

Peake, S., Barth, C., and McKinley, R.S. (1997). Effect of recovery parameters on critical swimming speed of juvenile rainbow trout (*Oncorhynchus mykiss*). *Can. J. Zool.* **75**, 1724-1727.

Peake, S. and McKinley, R.S. (1998). A re-evaluation of swimming performance in juvenile salmonids relative to downstream migration. *Can. J. Fish. Aquat. Sci.* **55**, 682-687.

Pedersen, H.P. and Amble, A. (2001). Holding tank system for reconditioning transport of live cod recently captured in deep water. *In Marketing and Shipping Live Aquatic Products, Proceeding of the Second International Conference and Exhibition,*

University of Alaska Sea Grant College Program, November, 1999, Seattle, WA, pp. 45–50.

Perry, S.F. and Kinkead, R. (1989). The role of catecholamines in regulating aerial oxygen content during acute hypercapnic acidosis in rainbow trout (*Salmo gairdneri*). *Respir. Physiol.* **77**, 365-378.

Pickering, A.D. (1981). *Stress and Fish*. New York: Academic Press.

Pickering, A.D. (1992). Rainbow trout husbandry: management of the stress response. *Aquaculture*, **100**, 125-139.

Pickering, A.D. and Pottinger, T.G. (1989). Stress response and disease resistance in salmonid fish: Effects of chronic elevation of plasma cortisol. *Fish Physiol. Biochem.* **7**, 253–258.

Pickering, A.D., Pottinger, T.G., and Christie, P. (1982). Recovery of the brown trout, *Salmo trutta* L., from acute handling stress: a time-course study. *J. Fish Biol.* **20**, 229-244.

Portz, D.E., Woodley, C.M., and Cech, Jr., J.J. (2006). Stress-associated impacts of short-term holding on fishes. *Rev. Fish Biol. Fish.* **16**, 125-170.

Pottinger, T.G. and Pickering, A.D. (1992). The influence of social interaction on the acclimation of rainbow trout, *Oncorhynchus mykiss* (Walbaum) to chronic stress. *J. Fish Biol.* **41**, 435–447.

Raines, R. (2001). *Tracy Fish Facility Improvement Program: Final Environmental Assessment and Initial Study*. U.S. Bureau of Reclamation, Denver Technical Service Center, Denver, CO.

Randall, D.J. and Perry, S.E. (1992). Catecholamines. In W.S. Hoar and D.J. Randall (eds.), *Fish Physiology*, Vol. 12 (pp. 255–300). New York: Academic Press.

Randall, D. J. and Wright, P.A. (1995). Circulation and gas transfer. In C. Groat, L. Margolis, and W.C. Clarke (eds), *Physiological Ecology of Pacific Salmon* (pp. 441–458). Vancouver, Canada: University of British Columbia Press.

Raquel, P. (1989). *Effects of handling and trucking on Chinook salmon, striped bass, American shad, steelhead trout, threadfin shad, and white catfish salvaged at the John E. Skinner Delta Fish Protection Facility*. California, Department of Fish and Game, Interagency Ecological Study Program for the Sacramento-San Joaquin Estuary, Technical Report 19.

Reid, S.G., Bernier, N.J., and Perry, S.F. (1998). The adrenergic stress response in fish: control of catecholamine storage and release. *Comp. Biochem. Physiol. C.* **120**, 1-27.

Rice, J.A., Crowder, L.B., and Binkowski, F.P. (1997). Evaluating potential sources of mortality for larval bloater (*Coregonus hoyi*): starvation and vulnerability to predation. *Can. J. Fish. Aquat. Sci.* **44**, 467-472.

Rieman, B.E., Beamesderfer, R.C., Viggs, S.E., and Poe, T.P. (1991). Estimated loss of juvenile salmonids to predation by northern squawfish, walleyes, and smallmouth bass in John Day Reservoir, Columbia River. *Trans. Am. Fish. Soc.* **120**, 448-458.

Robertson, L., Thomas, P., and Arnold, C.R. (1988). Plasma cortisol and secondary stress responses of cultured red drum (*Sciaenops ocellatus*) to several transportation procedures. *Aquaculture*, **68**, 115-130.

Rome, L.C., Funke, R.P., Alexander, R.M., Lutz, G., Aldridge, H., Scott, F., and Freadman, M. (1988). Why animals have different muscle fiber types. *Nature* **335**, 824-827.

Rome, L.C. and Sosnicki, A.A. (1991). Myofilament overlap in swimming carp II. Sarcomere length changes during swimming. *Am. J. Physiol., C* **260**, 289-296.

Ryer, C.H. (2002). Trawl stress and escapee vulnerability to predation in juvenile walleye Pollock: Is there an unobserved bycatch of behaviorally impaired escapees? *Mar. Ecol. Prog. Ser.* **232**, 269-279.

Ryer, C.H., Ottmar, M.L., and Sturm, E.A. (2004). Behavioral impairment after escape from trawl codends may not be limited to fragile fish species. *Fish. Res.* **66**, 261-269.

Schreck, C.B. (1982). Stress and rearing of salmonids. *Aquaculture* **28**, 241-249.

Schreck, C.B., Solazzi, M.F., Johnson, S.L., and Nickelson, T.E. (1989). Transportation stress affects performance of coho salmon, *Oncorhynchus kisutch*. *Aquaculture*, **82**, 15-20.

Schreck, C.B., Olla, B.L., and Davis, M.W. (1997). Behavioral responses to stress. In Iwama, G.K., Pickering, A.D., Sumpter, J.P., and Schreck, C.B. (eds.), *Fish Stress and Health in Aquaculture*, (pp. 145-170). New York: Cambridge University Press.

Schriefer, J.E. and Hale, M.E. (2004). Strikes and startles of northern pike (*Esox lucius*): a comparison of muscle activity and kinematics between S-start behaviors. *J. Exp. Biol.* **207**, 535-544.

- Seyle, H.** (1973). The evolution of the stress concept. *Am. Sci.* **61**, 692-699.
- Sharpe, R.L. and Milligan, C. L.** (2003). Lactate efflux from sarcolemmal vesicles isolated from rainbow trout *Oncorhynchus mykiss* white muscle is via simple diffusion. *J. Exp. Biol.* **206**, 543-549.
- Sharpe, C.S., Thompson, D.A., Blankenship, H.L., and Schreck, C.B.** (1998). Effects of routine handling and tagging procedures on physiological stress responses in juvenile Chinook salmon. *Prog. Fish-Cult.* **60**, 81-87.
- Sigismondi, L.A. and Weber, L.J.** (1988). Changes in avoidance response time of juvenile Chinook salmon exposed to multiple acute stresses. *Trans. Am. Fish. Soc.* **117**, 196-201.
- Smith, L.S.** (1982). Decreased swimming performance as a necessary component of the smolt migration in salmon in the Columbia River. *Aquaculture* **28**, 153-161.
- Soivio, A. and Nikinmaa, M.** (1981). The swelling of erythrocytes in relation to the oxygen affinity of the blood of the rainbow trout, *Salmo gairdneri* Richardson. In A.D. Pickering (ed), *Stress and Fish*. (pp. 103-119). London: Academic Press.
- Spierts, I.L.Y. and Van Leeuwen, J.H.** (1999). Kinematics and muscle dynamics of C- and S-starts of carp (*Cyprinus carpio* L.). *J. Exp. Biol.* **202**, 393-406.
- Steel, R.G.D., Torrie, J.H., and Dickey, D.A.** (1997). *Principles and procedures of statistics: a biometrical approach*. (3rd ed.). New York: McGraw-Hill.
- Strange, R.J. and Schreck, C.B.** (1978). Anaesthetic and handling stress on survival and cortisol concentration in yearling Chinook salmon (*Oncorhynchus tshawytscha*). *J. Fish. Res. Bd. Can.* **35**, 345-349.
- Strange, R.J. and Cech, J.J., Jr.** (1992). Reduced swimming performance of striped bass after confinement stress. *Trans. Am. Fish. Soc.* **121**, 206-210.
- Sylvester, J.R.** (1972). Effect of thermal stress on predator avoidance in sockeye salmon. *J. Fish. Res. Bd. Can.* **29**, 601-603.
- Sylvester, J.R.** (1973). Effect of light on vulnerability of heat-stressed sockeye salmon to predation by Coho salmon. *Trans. Am. Fish. Soc.* **102**, 139-142.
- Taylor, E.B. and McPhail, J.D.** (1985a). Prolonged and burst swimming in anadromous and freshwater threespine stickleback, *Gasterosteus aculeatus*. *Can. J. Zool.* **64**, 416-420.

- Taylor, E.B. and McPhail, J.D.** (1985b). Burst swimming and size-related predation of newly emerged coho salmon, *Oncorhynchus kisutch*. *Trans. Am. Fish. Soc.* **114**, 546-551.
- Taylor, E.B. and McPhail, J.D.** (1985c). Variation in burst and prolonged swimming performance among British Columbia populations of coho salmon, *Oncorhynchus kisutch*. *Can. J. Fish. Aquat. Sci.* **42**, 2029-2033.
- Temple, S.A.** (1987). Do predators always capture substandard individuals disproportionately from prey populations? *Ecology* **68**, 669-674.
- Thorpe, J.E. and Morgan, R.I.G.** (1978). Periodicity in Atlantic salmon, *Salmo salar*, smolt migration. *J. Fish Biol.* **12**, 541-548.
- Tucker, M.E., Williams, C.M., and Johnson R.R.** (1998). Abundance, food habits, and life history aspects of Sacramento squawfish and striped bass at the Red Bluff Diversion Complex, California, 1994-1996. *USFWS Red Bluff Research Pumping Plant Report 4*.
- Vijayan, M.M., Pereira, C., Grau, E.G., and Iwama, G.K.** (1997). Metabolic responses to confinement stress in tilapia: the role of cortisol. *Comp. Biochem. Physiol. C*, **116**, 89-95.
- Wainwright, P.C.** (1994). Functional morphology as a tool in ecological research. In P.C. Wainwright and S.M. Reilly (eds.), *Ecological morphology: integrative organismal biology* (pp. 42-59). Chicago: Chicago University Press.
- Wakeling, J.M.** (2006). Fast-start mechanics. In R.E. Shadwick and G.E. Lauder (eds.), *Fish Biomechanics*. (pp. 333-368). New York: Academic Press.
- Wakeling, J.M. and Johnston, I.A.** (1998). Muscle power output limits fast-start performance in fish. *J. Exp. Biol.* **201**, 1505-1526.
- Wardle, C.S.** (1975). Limits of fish swimming speed. *Nature* **255**, 725-727.
- Wardle, C.S. and He, P.** (1988). Burst swimming speeds of mackerel, *Scomber scombus* L. *J. Fish Biol.* **32**, 471-478.
- Watkins, T.B.** (2000). The effects of acute and developmental temperature on burst swimming speed and myofibrillar ATPase activity in tadpoles of the Pacific tree frog, *Hyla regilla*. *Physiol. Biochem. Zool.* **73**, 356-364.
- Webb, P.W.** (1976). The effect of size on the fast-start performance of rainbow trout *Salmo gairdneri* and a consideration of piscivorous predator-prey interaction. *J. Exp. Biol.* **65**, 157-177.

- Webb, P.W.** (1977). Effects of median-fin amputation on fast-start performance of rainbow trout (*Salmo gairdneri*). *J. Exp. Biol.* **68**, 123-135.
- Webb, P.W.** (1978a). Fast-start performance and body form in seven species of teleost fish. *J. Exp. Biol.* **74**, 211-236.
- Webb, P.W.** (1978b). Temperature effects on acceleration of rainbow trout *Salmo gairdneri*. *J. Fish. Res. Bd. Can.* **35**, 1417-1422.
- Webb, P.W.** (1982). Locomotor patterns in the evolution of actinopterygii fishes. *Am. Zool.* **22**, 329-343.
- Webb, P.W.** (1983). Speed, acceleration, and manoeuvrability of two teleost fishes. *J. Exp. Biol.* **102**, 115-122.
- Webb, P.W. and Corolla, R.T.** (1981). Burst swimming performance of northern anchovy, *Engraulis mordax*, larvae. *Fish. Bull.* **79**, 143-150.
- Webb, P.W., and Zhang, H.** (1994). The relationship between responsiveness and elusiveness of heat-shocked goldfish (*Carassius auratus*) to attacks by rainbow trout (*Oncorhynchus mykiss*). *Can. J. Zool.* **72**, 423-426.
- Weber, E.D., Borthwick, S.M., and Helfrich, L.A.** (2002). Plasma cortisol stress responses of juvenile Chinook salmon to passage through Archimedes lifts and a hidrostral pump. *N. Am. J. Fish. Manage.* **22**, 563-570.
- Wedemeyer, G.A.** (1976). Physiological response of juvenile coho salmon (*Oncorhynchus kisutch*) and rainbow trout (*Salmo gairdneri*) to handling and crowding stress in intensive fish culture. *J. Fish. Res. Bd. Can.* **33**, 2699-2702.
- Wedemeyer, G.A.** (1996). *Physiology of Fish in Intensive Culture Systems*. New York: Chapman and Hall.
- Wedemeyer, G.A and McLeay, D.J.** (1981). Methods for determining the tolerance of fishes to environmental stressors. In A.D. Pickering (ed.), *Stress and Fish* (pp. 247–275). London: Academic Press.
- Wedemeyer, G.A, Barton, B.A., and McLeay, D.J.** (1990). Stress and acclimation. In C.B. Schreck and P.B Moyle (eds.), *Methods for Fish Biology* (pp. 451–489). Bethesda, MD: American Fisheries Society.
- Weih, D.** (1973). The mechanism of rapid starting of slender fish. *Biorheology* **10**, 343-350.

- Wells, R.M.G., McIntyre, R.H., Morgan, A.K., and Davie, P.S.** (1986). Physiological stress responses in big gamefish after capture: observations on plasma chemistry and blood factors. *Comp. Biochem. Physiol A*, **84**, 565–571.
- Wendelaar Bonga, S.E.** (1997). The stress response in fish. *Physiol. Rev.* **77**, 591–625.
- Wilson, R.S. and Franklin, C.E.** (1999). Effect of ontogenetic increases in body size on burst swimming performance in tadpoles of the striped marsh frog, *Limnodynastes peronii*. *Physiol. Biochem. Zool.* **73**, 142-152.
- Wood, C.M. and Perry, S.F.** (1985). Respiratory, circulatory, and metabolic adjustments to exercise in fish. In R. Gilles (ed.), *Respiration, Metabolism, and Circulation* (pp. 2-22). Berlin: Springer-Verlag.
- Woodward, C.C. and Strange, R.J.** (1987). Physiological stress responses in wild and hatchery-reared rainbow trout. *Trans. Am. Fish. Soc.* **116**, 574–579.
- Yin, M.C. and Baxter, J.H.S.** (1987). Escape speeds of marine fish larvae during early development and starvation. *Mar. Biol.* **96**, 459-468.
- Yin, Z., Lam, T.J., and Sin, Y.M.** (1995). The effects of crowding stress on the non-specific immune response in fancy carp (*Cyprinus carpio L.*). *Fish Shellfish Immunol.* **5**, 519–529.
- Yamamoto, K.** (1987). Contraction of spleen in exercised cyprinid. *Comp. Biochem. Physiol. A*, **87**, 1083-1087.
- Yamamoto, K.** (1988). Contraction of spleen in exercised freshwater teleost. *Comp. Biochem. Physiol. A*, **89**, 65-66.
- Yocom, T.G., and Edsall, T.A.** (1974). Effect of acclimation temperature and heat shock on vulnerability of fry of lake whitefish (*Coregonus clupeaformis*) to predation. *J. Fish. Res. Bd. Can.* **31**, 1503-1506.
- Yoshiyama, R.M., Fisher, F.W., and Moyle, P.B.** (1998). Historical abundance and decline of Chinook salmon in the Central Valley region of California. *N. Am. J. Fish. Manage.* **18**, 487-521.
- Yoshiyama, R.M., Gerstung, E.R., Fisher, F.W., and Moyle, P.B.** (2000). Chinook salmon in the California Central Valley: an assessment. *Fisheries* **25**, 6-20.
- Young, P.S. and Cech, J.J., Jr.** (1993). Effects of exercise conditioning on stress responses and recovery in cultured and wild young-of-the year striped bass, *Morone saxatilis*. *Can. J. Fish. Aquat. Sci.* **50**, 2094-2099.

Young, G., Björnsson, B.T., Prunet, P., Lin, R.J., and Bern, H.A. (1989). Smoltification and seawater adaptation in coho salmon (*Oncorhynchus kisutch*): Plasma prolactin, growth hormone, thyroid hormones, and cortisol. *Gen. Comp. Endocrinol.* **74**, 335-345.

Zar, J.H. (1984). *Biostatistical Analysis*. Toronto: Prentice-Hall.