

RECLAMATION

Managing Water in the West

Evaluation of a Cylindrical Wedge-Wire Screen System at Beal Lake, Arizona 2006

Phase II Testing



U.S. Department of the Interior
U.S. Bureau of Reclamation
P.O. Box 61470
Boulder City, NV 89006-1470



Normandeau Associates Inc.
Environmental Consultants
40 Cascade Ave, Suite 40
Stevenson, WA 98648

January 2007

Evaluation of a Cylindrical Wedge-Wire Screen System at Beal Lake, Arizona 2006

Phase II Testing

Normandeau Associates Inc.
Contract No. GS10F0319M
Order No. 05PE303177 Mod#0001

by

Christopher M. Karchesky
Robert D. McDonald



U.S. Department of the Interior
U.S. Bureau of Reclamation
Lower Colorado Regional Office, LC 8455
P.O. Box 61470
Boulder City, NV 89006-1470



Normandeau Associates Inc.
Environmental Consultants
40 Cascade Ave, Suite 40
P.O. Box 1159
Stevenson, WA 98648

January 2007

EXECUTIVE SUMMARY

Beal Lake is a historical backwater on the Lower Colorado River that is being developed as a protected habitat for native lower Colorado River fishes. As a part of the United States Bureau of Reclamation's (Reclamation's) on going commitment to compliance with the terms of the Endangered Species Act, major improvements were made to this backwater to make it suitable for native fishes. These improvements include, but are not limited to, the installation of a permeable rock structure to prevent passage of nonnative fish into Beal Lake from the adjacent Topock Marsh. While the rock structure was assumed to have effectively blocked passage of nonnative fish, it was found to be passing an inadequate volume of water to balance evaporative losses from Beal Lake during summer months. As part of Reclamation's continued commitment to providing protected habitats for native lower Colorado River fishes under the Lower Colorado River Multi-Species Conservation Program, the rock structure was modified with the installation of a prototype cylindrical wedge-wire screen system. The screen system consists of four 18 inch diameter pipes, three of which are equipped with 36 inch cylindrical wedge-wire screens with a slot width of 0.6 mm (0.024 inches) and constructed of a nickel-copper (CuNi) alloy that is intended to inhibit biological growth on the screens.

This report summarizes the second year of a two year study to evaluate the screen system. Three objectives were established for the second year: 1.) to evaluate the effectiveness of the screen system at excluding all life stages of nonnative fishes from Beal Lake; 2.) to evaluate the effectiveness of the CuNi alloy used to construct the screen systems as an anti-biofouling agent; and 3.) to continue to maintain and monitor the data collected by the on-site water level monitoring station installed at Beal Lake in 2005.

A hydraulic flume was used to determine the effectiveness of the screen system at excluding all life stages of nonnative fishes. Three size classes of eggs and larvae were selected to be tested and represented three size classes of nonnative species that are found in the Lower Colorado River drainage. Gizzard shad *Dorosoma cepedianum* were used to represent the smallest size class of fish eggs (< 1 mm diameter) and larvae (< 5 mm in length). Fathead minnow *Pimephales promelas* were used to represent the medium size class of eggs (1-2 mm diameter), and smallmouth bass *Micropterus dolomieu* were used to represent the medium size class of larvae (5 – 10 mm in length). The largest size class of eggs (> 2 mm diameter) and larvae (>10 mm in length) were represented by blue catfish *Ictalurus furcatus*. Fertilized eggs and larvae were obtained from various commercial vendors prior to testing.

A screen having the same flow characteristics and slot width (0.6 mm) as the screens installed at Beal Lake was mounted in the hydraulic flume. Entrainment was tested under three slot velocities (0.10, 0.21, and 0.42 ft/s), and all tests were conducted with static flow conditions in the flume (*i.e.*, the only flow was through the screens). Eggs and larvae were introduced directly above the screen and allowed to drift down on its surface. All flow that passed through the screen was directed into a collection tank, and all entrained organisms were recovered using a 335-micron plankton net deployed in the tank. All organisms that passed through the screen and collected were enumerated, and their condition recorded.

Of the three size classes tested, only eggs and larvae from the small size class passed through the wedge-wire screen. At all three slot velocities tested, the eggs and larvae of gizzard shad were recovered in the plankton net deployed in the collection tank. Eggs and larvae from the other two size classes tested were not entrained through the test screen at any of the three slot velocities tested.

To assess the effectiveness of the CuNi alloy at preventing biofouling, screen samples constructed of CuNi alloy were compared with those constructed from 304 stainless steel. A total of 20 screen coupons (10 of each material) were deployed at two study sites. The screen coupons were deployed in April 2006 and were retrieved bimonthly. Upon retrieval, the coupons were photographed, and each coupon was individually scrubbed to remove any biofouling. All material removed from the screens was sealed in 500 ml collection jars, placed on ice, and shipped for laboratory analysis of species composition and ash-free-dry-mass (AFDM).

Based on visual observations, the CuNi coupons appeared to be very effective at resisting biofouling when compared to the stainless steel coupons. During each sampling period following deployment, the CuNi screen coupons were nearly devoid of any biofouling material. The biofouling that did occur was easily removed, and did not appear to cause blockage of the interstitial screen space. In contrast, we found extensive biofouling of the stainless steel coupons. The composition of organisms contributing to the biofouling varied seasonally, but generally consisted of green filamentous algae or cyanobacteria covered with silt and organic debris. This mixture formed a thick gelatinous composite that completely covered the entire surface of the coupons. Our analysis of AFDM was consistent with our visual observations, as a significant difference in AFDM was found between the two coupon types. The difference in biofouling resistance was less pronounced in November when water temperatures cooled.

Modifications were made to the remote water level monitoring station at Beal Lake, which was installed initially in 2005. These modifications increased the permanence and robustness of the long-term monitoring station by enhancing the in-water housing for the water level sensors and securing all data cables in underwater and underground conduits.

Water levels on either side of the rock structure were monitored through 2006. Water levels remained approximately 0.5 to 1.0 ft lower in Beal Lake than Topock Marsh throughout the summer and early fall. This was likely attributed to management actions that required the screen system to be closed and the water level of Beal Lake to be drawn down in April. Water flow into Beal Lake was restored by early May, however, water levels on either side of the rock structure did not return to equilibrium until late October, when evapotranspiration rates decreased.

TABLE OF CONTENTS

EXECUTIVE SUMMARY	ES-1
1.0 INTRODUCTION AND OBJECTIVES	1
2.0 STUDY AREA	2
3.0 MATERIALS AND METHODS	6
3.1 Objective 1. – Determine the effectiveness of the screen system at excluding all life stages of nonnative fishes.	6
3.1.1 Test Facility Design	6
3.1.2 Fish Procurement and Holding	7
3.1.3 Fish Exclusion Testing	9
3.1.4 Data Analysis	9
3.2 Objective 2. – Evaluate the Effectiveness of the antibiofouling screen material in inhibiting biological growth.	10
3.2.1 Test Sample Deployment	10
3.2.2 Water Quality	12
3.2.3 Data Analysis	12
3.3 Objective 3. – Continued Maintenance and Data Management of Existing Water Level Monitoring Station	13
4.0 RESULTS	14
4.1 Objective 1. – Determine the effectiveness of the screen system at excluding all life stages of nonnative fishes.	14
4.1.1 Fish Exclusion Testing	14
4.2 Objective 2. – Evaluate the Effectiveness of the antibiofouling screen material in inhibiting biological growth.	18
4.2.1 Visual Observations	18
4.2.2 Ash Free Dry Mass (AFDM)	20
4.2.3 Water Quality	20
4.3 Objective 3. – Continue maintenance and data management of existing water level monitoring station.	23
5.0 DISCUSSION	25
6.0 Literature Cited	29
APPENDIX A	31
APPENDIX B	33
APPENDIX C	35

LIST OF TABLES

- Table 1. Design and operational parameters for the Beal Lake screens based on data presented in Normandeau (2006), and the design and operational parameters for the laboratory test screen evaluated at ALDEN in 2006.
- Table 2. Three size classes of nonnative species of interest, the surrogate species tested at ALDEN, and measurements of eggs and larvae of surrogate species.
- Table 3. Dichotomous classification of entrainment for the three size classes of eggs and larvae tested at the ALDEN in 2006.
- Table 4. Study start dates (date screens were deployed) and subsequent sampling dates in 2006. Numbers in parentheses indicate the number of days between each sampling period.
- Table 5. Water quality data recorded during each sampling period for biofouling at Beal Lake and Martinez Lake, Arizona, 2006.

LIST OF FIGURES

- Figure 1. Study area map of Beal Lake in relation to Martinez Lake along the Lower Colorado River, Arizona.
- Figure 2. Aerial photo of rock structure located on the inlet canal between Topock Marsh and Beal Lake, Arizona.
- Figure 3. Plan view and side view schematics of the rock structure with installed prototype cylindrical wedge-wire screen system. Insert depicts wedge-wire screen technology.
- Figure 4. Plan view and side view schematics of the cylindrical wedge-wire screen test facility at Alden Research Laboratory.
- Figure 5. Irrigation pump and location of screen samples deployed at Beal Lake, Havasu National Wildlife Refuge.
- Figure 6. Irrigation pump and location of screen samples deployed at Martinez Lake inlet canal, Imperial National Wildlife Refuge.
- Figure 7. Screen coupons attached to PVC frame using nylon zip-ties prior to deployment.
- Figure 8. Size perspective of gizzard shad eggs and newly emerged larvae.
- Figure 9. Size perspective of newly emerged blue catfish larvae.
- Figure 10. Biofouling of test coupons prior to cleaning at Beal Lake (A) and Martinez Lake inlet canal (B) for sample interval April – June.
- Figure 11. Ash Free Dry Mass (AFDM) averaged by screen type at each location during each sampling period. Significant differences ($P < 0.05$) are indicated by different alphabetic superscripts.
- Figure 12. Mean daily water temperatures recorded at each biofouling test site from April through November, 2006.
- Figure 13. Mean daily water level differences between Topock Marsh and Beal Lake, 2006. Water level differences from 21 June to 4 July were removed from analysis. Mean daily water level differences by month are presented in Appendix C.

1.0 INTRODUCTION AND OBJECTIVES

Several species of native Colorado River fishes, including the razorback sucker (*Xyrauchen texanus*) and the bonytail chub (*Gila elegans*), have been listed as endangered species under the terms of the Endangered Species Act (ESA; Minckley 1983; Mueller 2005a). Human modifications to the lower Colorado River system have fundamentally changed the hydraulic characteristics of the river and the conditions under which these species evolved (Minckley and Deacon 1968; Fradkin 1981). These altered river conditions favored the population growth of introduced nonnative fishes that have existed in the system since the late nineteenth century (Dill 1944). Early declines of native fish were attributed to habitat alternations caused by dam construction. However, over the past few decades, research has shown that competition and predation from nonnative species is likely the most consequential factor preventing the continued existence and potential recovery of endangered native fishes (Meffe 1985; Minckley 1991; Marsh and Pacey 2005). As it is doubtful that the hydraulic conditions of the Colorado River will ever resemble the conditions found historically, and it would be nearly impossible to extirpate nonnative fishes completely from the system, one recovery strategy currently being investigated is the creation of isolated, predator-free habitats for native fishes (Mueller 2005a). Creation of isolated, predator-free habitats involves renovating and protecting backwaters along the Colorado River by improving habitat conditions (*i.e.*, dredging), chemically removing all nonnative fishes, and restocking these areas with native fauna. The success of these projects depends primarily on the continued exclusion of nonnative fishes.

The U.S. Bureau of Reclamation (Reclamation) is required to create 360 acres of backwater dedicated to native fish species along the lower Colorado River. These backwaters can either be connected or disconnected from the river. [The preferred type of backwater under the program is disconnected and virtually free of nonnative fishes]. Under this requirement, protected backwaters should provide habitat for endangered native fishes and inhibit the invasion and subsequent recolonization of nonnative fauna. Beal Lake, located on Havasu National Wildlife Refuge near Needles, CA was identified as a candidate backwater to develop as a protected habitat for native fishes. Improvements to Beal Lake included substantial dredging and the installation of a permeable rock filtration system (hereafter referred to as “the rock structure”). The rock structure is located on the inlet canal between Topock Marsh and Beal Lake. This inlet canal provides the only surface connection between Beal Lake and the lower Colorado River. The rock structure spans the entire width of the inlet canal and was designed to exclude all life stages of nonnative fish while allowing an adequate volume of water to enter Beal Lake to balance evaporative losses (Love and Vizcarra 2000).

Shortly after the installation of the rock structure, a difference was observed between the elevation of the surface water in Topock Marsh and Beal Lake. This difference became pronounced (nearly 2 ft) in subsequent months (personal communications Gregg Garnett, Bureau of Reclamation, Boulder City, NV). It was determined that the permeable filter within the rock structure was at least partially clogged with silt and other suspended particulates and was not passing an adequate volume of water to balance evaporative losses from Beal Lake. The inadequate performance of the rock structure provided the impetus for an investigation of alternate technologies and/or modifications that could improve water flow into Beal Lake and still prevent passage of nonnative fishes. Based on a thorough review of the literature, Reclamation chose to experiment with technologies to modify the existing rock structure and added a total of four pipes, each with a diameter of 18 inches, through the rock structure to provide additional flow into Beal Lake. In an attempt to inhibit the movement of fish through the pipes, high-volume, cylindrical wedge-wire screens were installed at either end of the installed pipes (referred to as “the screen system”).

In 2005, the hydraulic capacity of the cylindrical wedge-wire screen system was evaluated as a part of Phase I testing (Normandeau 2006). Results of this evaluation indicated that the screen system provides adequate water flow to compensate for the evaporative water losses from Beal Lake. While these results were encouraging, further testing was necessary before a determination could be made regarding the effectiveness of the system at inhibiting nonnative fish passage. Another question regarding the importance of the using a biofouling resistant screen material also needed to be addressed. The specific objectives of the Phase II evaluation were to:

- Objective 1.* Determine the efficiency of the screen system at excluding all life stages of nonnative fishes;
- Objective 2.* Continue to evaluate the effectiveness of the anti-biofouling screen material in inhibiting biological growth; and
- Objective 3.* Continue maintenance and data management of existing water level monitoring station.

2.0 STUDY AREA

Beal Lake is a 225-acre backwater located adjacent to Topock Marsh on the Havasu National Wildlife Refuge in Mohave Valley, Arizona (Figure 1). The rock structure and screen system are located on the northern end of the inlet canal, which supplies water from Topock Marsh to Beal Lake (Figure 2). Beal Lake and Topock Marsh are both eutrophic water bodies, and contain a high amount

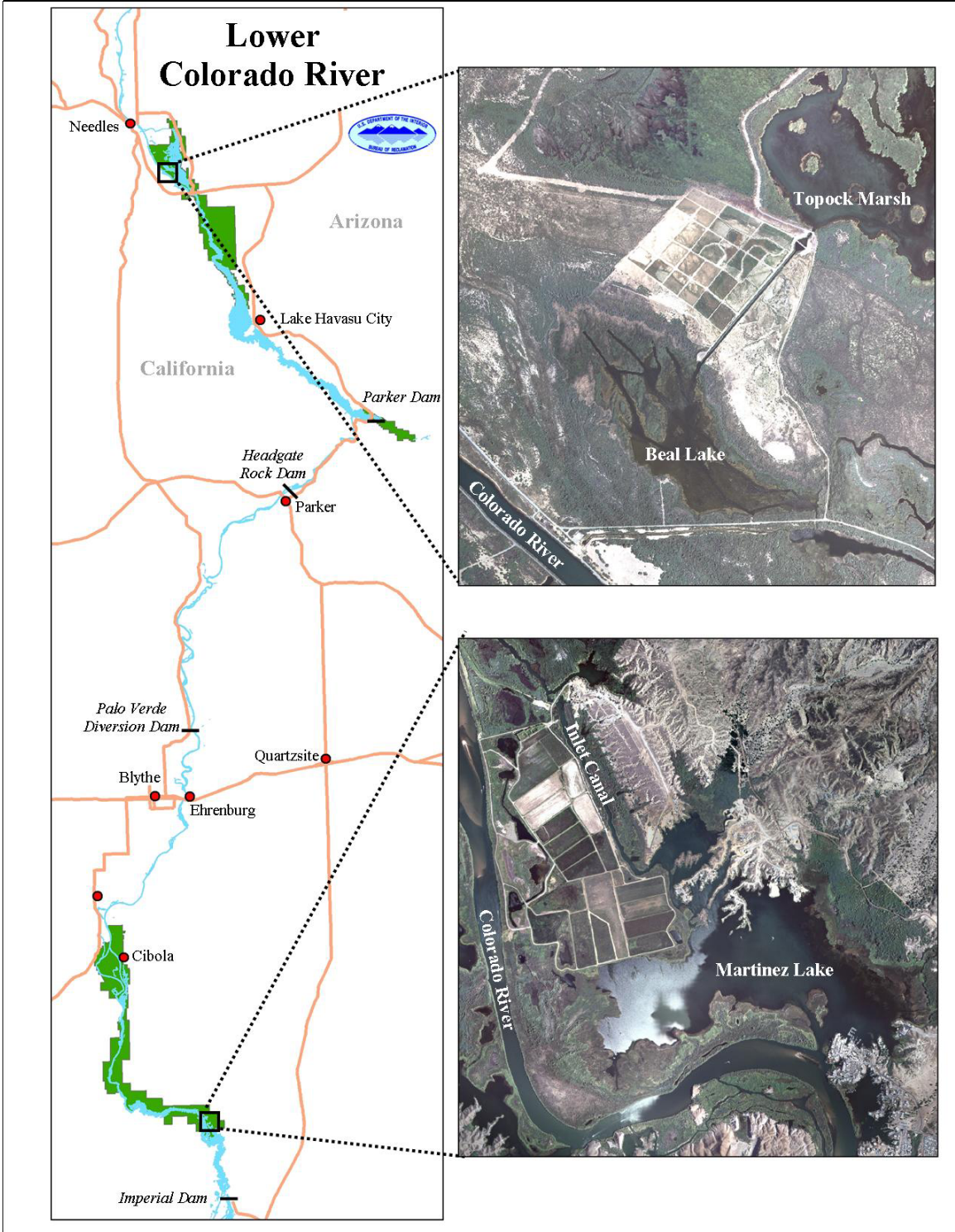

Figure 1. Study area map of Beal Lake in relation to Martinez Lake along the Lower Colorado River, Arizona.

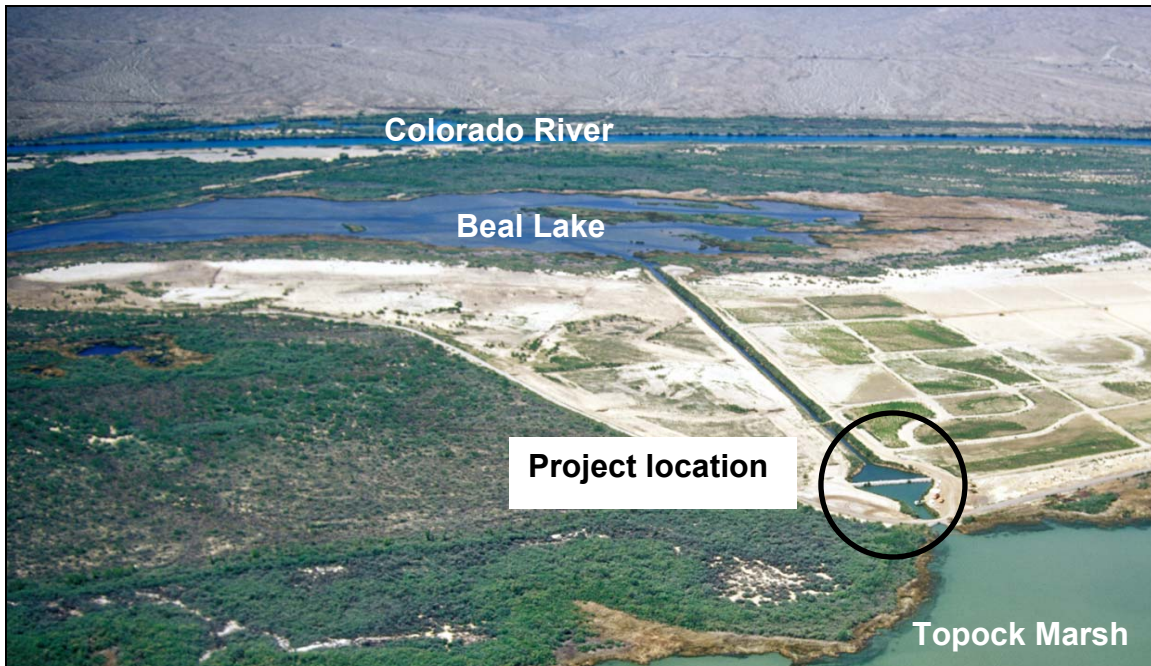

Figure 2. Aerial photo of rock structure located on the inlet canal between Topock Marsh and Beal Lake, Arizona.

of suspended solids in the water column (King *et al.* 1993). Water from the Colorado River enters Topock Marsh through control gates at the South Dike outlet structure (USGS gage no. 09423550, Topock Marsh Inlet near Needles, CA). Water elevations in Topock Marsh and Beal Lake vary through the year, but are generally highest in May-June and lowest in December-January (surface elevation 456.7 ft in summer to 454.7 ft in winter; elevations based on in NAD 27 datum). Local climate in the area is seasonally variable and extreme, with wintertime air temperatures dropping below 30° F and summertime temperatures exceeding 120° F. Evapotranspiration from marsh vegetation on the refuge is estimated to be highest in June (11.14 in/month), and lowest in November (0.60 in/month; BOR 2003).

The screen system is comprised of four 18 inch diameter PVC pipes. Three of these pipes are equipped with cylindrical wedge-wire screens at each end; the remaining pipe is currently capped and may be fitted with screens if additional flow is necessary (Figure 3). An in-line valve was installed in the middle of each pipe that can be accessed from the surface of the rock structure, to allow the pipes to be closed when necessary (*e.g.*, to reduce water flow into Beal Lake or to allow for repair or replacement of screens). The screens were constructed of a copper-nickel (CuNi) alloy that is manufactured and marketed as an anti-biofouling agent. Each screen is equipped with an internal diffuser and 3-inch air backwash system designed to clean the screens when necessary. The diameter

of each screen cylinder is 33.25 inches, and each cylinder is 36.56 inches long (Appendix A). The screen slot size is 0.6 mm (0.024 inches). This slot size was chosen in an attempt to exclude the smallest egg and larval of nonnative fishes currently found in the lower Colorado River drainage (*i.e.*, threadfin shad *Dorosoma petenense*). Each screen has a design flow capacity of 1,500 gpm.

Martinez Lake was selected as second study site to evaluate the effectiveness of the anti-biofouling screen material. Martinez Lake is a naturally occurring backwater of the Lower Colorado River, and is located in southern Arizona approximately 35 miles north of the city of Yuma and 7 miles upstream of Imperial Dam (Figure 1). The total surface area of the lake is approximately 610 acres and has a maximum water depth of about 15 feet. The western third of the lake is contained within the Imperial National Wildlife Refuge. Unlike Beal Lake, Martinez Lake is connected directly to the Colorado River, resulting in different water quality conditions which may affect biofouling.

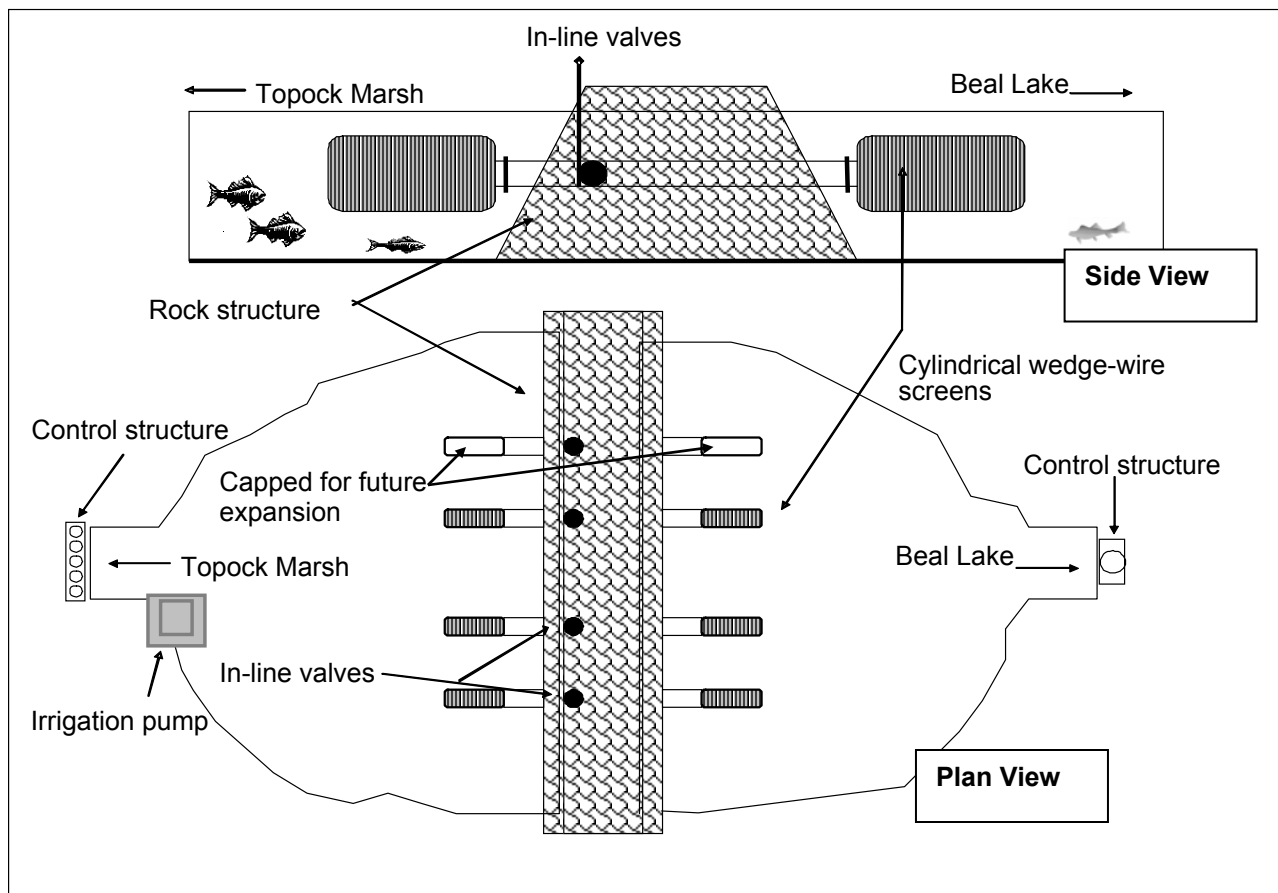

Figure 3. Plan view and side view schematics of the rock structure with installed prototype cylindrical wedge-wire screen system. Insert depicts wedge wire screen technology

3.0 MATERIALS AND METHODS

3.1 Objective 1. – Determine the effectiveness of the screen system at excluding all life stages of nonnative fishes.

A hydraulic flume was used to determine the effectiveness of the screen system at excluding all life stages of nonnative fishes. The decision to use a hydraulic flume under laboratory conditions was based on the logistical constraints associated with controlling test conditions in the field, the lack of confidence in the ability to retrieve all of the test specimens after testing, and the possibly introducing nonnative fishes into Beal Lake. Alden Research Laboratories (ALDEN), in Holden MA, were contracted to perform the fish exclusion test in a section of their fish testing flume. The flume was modified specifically for conducting biological entrainment evaluations with cylindrical wedge-wire screens.

3.1.1 Test Facility Design

The channel of the hydraulic flume measured 6 ft in width and 6 ft in height (Figure 4). Water depths within the flume are generally set between 5 to 5.5 ft depending on required flow rates. At these depths, channel velocities approaching 3 ft/s can be maintained throughout the length of the flume. A full-depth plexiglass window was installed adjacent to the screen to allow for real-time visual observations and video recording during screen testing.

A single cylindrical wedge-wire screen with a 0.6 mm (0.024 inches) slot width was used for the exclusion efficiency evaluation. The screen had a diameter of 24 inches, measured 24 inches in length and had a porosity of approximately 28%. Although smaller in length and diameter than the Beal Lake screens, the test screen provided an accurate surrogate to estimate of fish exclusion efficiency because the through-slot velocities of the test screen were set to identical conditions measured in situ (Table 1; Normandeau 2006).

Fish eggs and larvae were introduced immediately in front and above the test screen using a release system designed to have minimal flow velocity, yet still propel the test organisms onto the screen surface. The release system consisted of a small holding tank from which eggs or larvae were injected into a 2 inch diameter flex tube that exited near the surface of the screen (Figure 4). All flow that passed through the screen was directed into a collection tank. Entrained organisms (*i.e.*, those that had passed through the screens) were carried by the flow into the collection tank and were recovered from a 335-micron plankton net positioned in the tank. After each test was completed,

eggs and larvae that were not entrained were flushed downstream, and were removed from the flume in a 335-micron plankton net located about 12 ft downstream of the test screen. The flume was flushed after each test to ensure that no organisms from previous tests remained susceptible to entrainment.

Water clarity within the flume was maintained during testing by filtering the test facility water through a series of bag filters with pore sizes between 10 and 50 microns. An underwater color video camera was positioned adjacent from the release pipe. Preliminary releases were conducted to identify the appropriate camera location and lighting conditions that maximized the visibility of eggs and larvae as they were released into the test flume and came in contact with the test screen.

3.1.2 Fish Procurement and Holding

The primary nonnative species of interest for the exclusion effectiveness evaluation were threadfin shad, largemouth bass *Micropterus salmoides*, and flathead catfish *Pylodictis olivaris*; all of which are introduced species currently found in the lower Colorado River drainage. In addition, these three species were chosen as they represent three sizes classes of nonnative fish whose early life stages may potentially interface with the screen system.

Table 1. Design and operational parameters for the Beal Lake screens based on data presented in Normandeau (2006), and the design and operational parameters for the laboratory test screen evaluated at ALDEN in 2006.

Parameter	Beal Lake Screens (33 in diameter)			Laboratory Test Screen (24 in diameter)		
<i>Screen Design</i>						
Screen Diameter (in)	33.25			24		
Slot Size (mm)	0.6			0.6		
Screen Length (in)	36.56			24.00		
Screen Porosity (%)	29.63			28.25		
<i>Flow Conditions</i>						
Pipe Velocity (ft/s)	0.50	1.00	2.00	0.47	0.94	1.90
Slot Velocity (ft/s)	0.10	0.21	0.42	0.10	0.21	0.42
Flow Rate (cfs)	0.82	1.65	3.29	0.37	0.74	1.49
Flow Rate (gpm)	369	739	1478	167	334	668

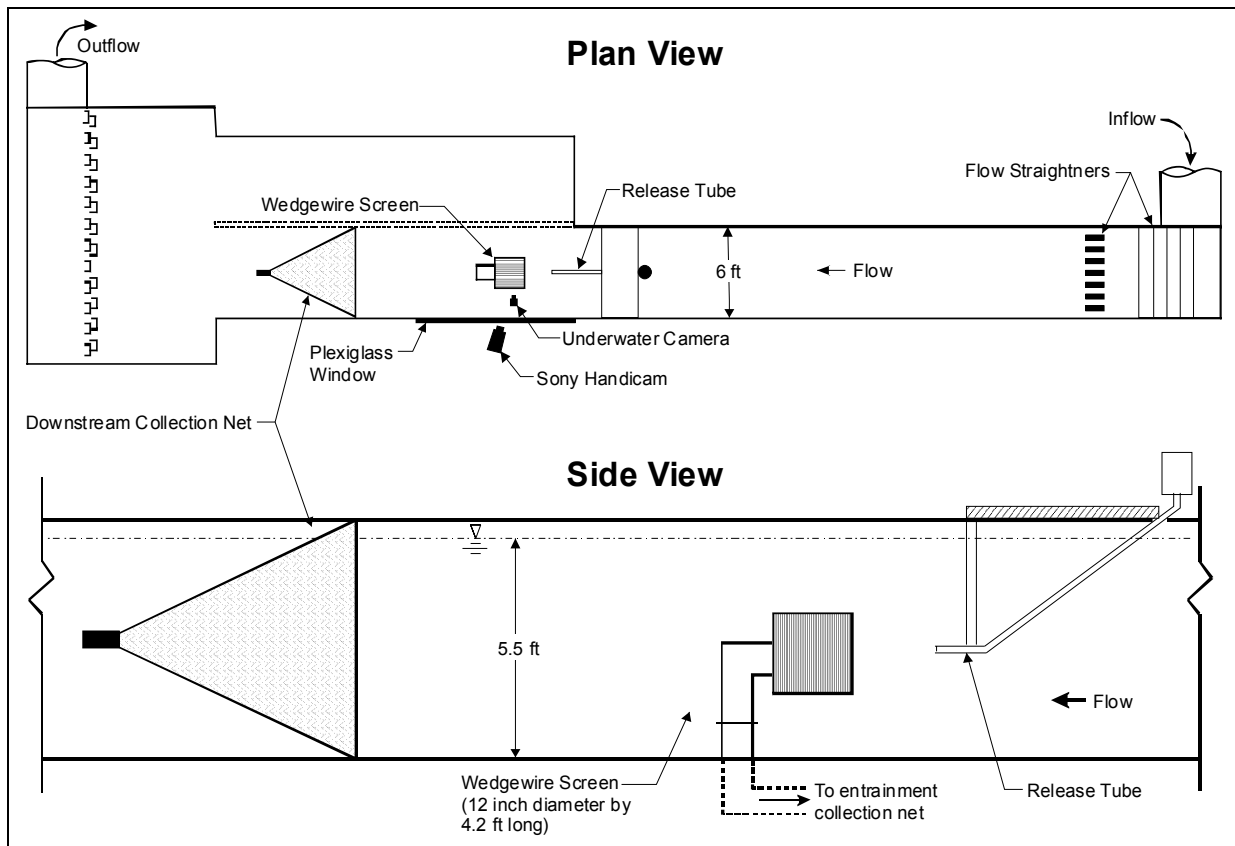

Figure 4. Plan view and side view schematics of cylindrical wedge wire screen test facility at Alden Research Laboratory.

A sufficient number of fertilized eggs were obtained from various commercial vendors. Eggs were immediately placed in re-circulating fish holding systems specifically designed for hatching eggs and rearing fish larvae. Each system was equipped with a biofilter, cartridge filter, carbon filter, and a UV sterilization filter. Depending on species-specific requirements, some eggs were held in McDonald hatching jars located inside larval rearing tanks or on mats placed on the bottom of the tanks. After yolk sac absorption, larvae were fed live artemia (*i.e.*, brine shrimp) three to four times per day. Appropriate water temperature for each species was maintained using a chiller/heater unit. Water quality conditions (*e.g.*, dissolved oxygen, temperature, and pH) in the holding facilities as well as in the test flume were measured throughout the day. Established water quality criteria for each species and life stage were followed to maintain the appropriate conditions in the flume and the holding facilities.

3.1.3 Fish Exclusion Testing

Each species and life stage was evaluated under three slot velocities: 0.10, 0.21, and 0.42 ft/s. These slot velocities corresponded to a range of pipe velocities (0.5, 1.0, and 2.0 ft/s; Table 1) that were observed at various head differentials across the rock structure (Normandeau 2006). To best replicate the lacustrine conditions at Beal Lake, all tests were conducted under static channel flow (*i.e.*, the only water flow in the test flume was the result of water being withdrawn by the screen). Up to three replicate trials were conducted for each test scenario and fish species. Each trial was 10 minutes in duration (*i.e.*, the amount of time flow was allowed through the screen following the release of eggs or larvae). Approximately 100 organisms were released per trial. Eggs and larvae of smaller species (*e.g.*, gizzard shad and fathead minnow) were soaked in a solution of neutral red stain (30 mg per 1 L of water) for approximately 30 to 60 minutes to make them more visible as they encountered the screen and during the entrainment collection process.

For each trial, the number of eggs and larvae recovered from the plankton collection net were recorded. Collection efficiency of the net was estimated by releasing a known number of eggs and larvae directly in front of the collection net. Prior to testing, a sub-set of eggs and larvae were removed and measured to determine mean egg diameter and mean larval length and head capsule width. Measurements were not taken of organisms entrained through the screen, as damage to some of the eggs and larvae following entrainment precluded accurate body measurements from being recorded. The condition of eggs and larvae collected in the entrainment net were also recorded.

3.1.4 Data Analysis

Because entrainment was tested under static flow conditions, we assumed that if a portion of the eggs and/or larvae were entrained, then all other eggs and/or larvae of similar size had the same potential of passing through the screen. This type of approach is more conservative than calculating percent entrainment, the metric which has been typically used to evaluate wedge-wire screen entrainment in environments where not all flow is directed through the screens (Hanson et al. 1978; Lifton et al. 1979; Hanson 1981; Otto et al. 1981). Since complete exclusion of nonnative fish from a protected backwater is the desired outcome, and any entrainment of nonnative fishes through the screens may require further management actions, we assessed entrainment based on a dichotomous classification scheme rather than based on percent entrainment.

3.2 Objective 2. – Evaluate the Effectiveness of the antibiofouling screen material in inhibiting biological growth.

Based on the recommendation presented in Normandeau (2006), we further tested the effectiveness of the CuNi screen material at inhibiting biological growth. The literature suggests that when submerged in water, a copper patina forms on the alloy that prevents the adhesion and subsequent growth of aquatic organisms. This evaluation was conducted using a larger number of screen samples than used in 2005 to provide a more statistically valid assessment. This evaluation was also conducted over a longer time period than in 2005 and was extended into waters closer to the Colorado River where water quality conditions can differ from those found in Beal Lake.

3.2.1 Test Sample Deployment

A total of forty screen coupons, one-half comprised of a CuNi alloy and one the other half consisting of 304 stainless steel (stainless steel) measuring approximately 4 inches in length and 4 inches in width were procured. Half of the screens (10 CuNi alloy; 10 stainless steel) were deployed at the irrigation pump located adjacent to the rock structure at Beal Lake (Figure 5). The remaining half were deployed at the pump station located on the inlet canal of Martinez Lake (Figure 6).

Frames to support the screen coupons in the water column were fabricated using Poly Vinyl Chloride (PVC) pipe (schedule 40) and heavy-duty PVC glue (Figure 7). A 1/8 inch hole was drilled in each corner of the coupons, and nylon zip-ties were used to suspend the screens within the PVC frame. The zip-ties were used as they provided adequate holding strength, and facilitated easy removal of the coupons. Coupons were attached to the frames and the frames were suspended with the wedge-wire oriented in a horizontal direction. Each frame contained five CuNi coupons and five stainless steel, and a total of two frames were suspended at each test location. On each frame the CuNi and stainless steel coupons were alternated from top to bottom to ensure even distribution in the water column. At each location, samples were oriented facing the northern horizon and suspended from an existing pump intake platform approximately 4 feet below the water surface. Nylon rope was used to secure the PVC frame to the side of each pump station. Care was taken to insure that the samples did not come into contact with each other, the PVC frame, or the steel framing of the pump platform.



Figure 5. Irrigation pump and location of screen samples deployed at Beal Lake, Havasu National Wildlife Refuge.



Figure 6. Irrigation pump and location of screen samples deployed at Martinez Lake inlet canal, Imperial National Wildlife Refuge.



Figure 7. Screen coupons attached to PVC frame using nylon zip-ties prior to deployment.

3.2.2 Water Quality

Water-quality measurements were collected at each site during the initial deployment and during subsequent retrieval and redeployment of the test coupons. These measurements included temperature, turbidity, specific conductivity, dissolved oxygen, salinity, and pH. In addition, data logging sensors were deployed at each test location and set to recorded hourly water temperatures.

3.2.3 Data Analysis

The screen samples were retrieved approximately bimonthly following initial deployment in the spring. Immediately following their retrieval, the samples were photographed. Each screen was then individually scrubbed, and all the contents sealed in 500 ml collection jars, placed on ice, and shipped immediately, via overnight courier, to the Normandeau Biological Laboratory for analysis.

At the lab, a portion of the sample was removed for ash-free dry mass (AFDM) analysis and processed immediately. AFDM analysis was performed as described in Standard Methods for the Examination of Water and Wastewater (Eaton et al. 2005). Briefly, once the samples arrived from

the field, they were transferred to a beaker and the total sample volume determined. The samples were then homogenized by mixing the sample with a Hensen-Stempel pipette. The Hensen-Stempel pipette was then used to collect 10-ml subsample aliquots which were filtered through pre-cleaned and pre-weighed 0.45 micron filters using vacuum filtration. The number of aliquots taken from a sample was determined by filter clogging. The total volume of sample filtered was recorded. Samples were placed in an oven at 221° F and dried to constant weight. All weight measurements were recorded on an analytical balance with 0.0001 gram accuracy. Samples were then placed in a muffle furnace and incinerated for 1 hour at 932° F. Incinerated samples were re-wetted, and returned to the drying oven and dried to a constant weight at 221° F. The dry weight of the sample was then determined by the initial dry weight minus the tare weight (filter and pan). AFDM is the difference between the dry weight before and after incineration. The number of milligrams dry weight and AFDM per grid (sample) was determined by multiplying the weight by the total volume of sample divided by the subsample volume. Differences in overall biomass between screen types and between test locations were tested using a nonparametric Kruskal-Wallis test ($P < 0.05$; Zar 1984).

The remaining sample was then examined to determine the physical and biological composition. The five replicates from each site and screen material were then combined. The combined sample was passed through a 0.5 mm sieve to separate the macroinvertebrates from the microbial community and detritus. The major components of the sample that remained in the 0.5 mm portion of the sample were then listed along with any non-countable organisms (*i.e.*, fragments of colonial organisms and large algal species). All other macroinvertebrate organisms remaining in the 0.5 mm portion of the sample were identified to lowest practical taxon and enumerated. The microbial/detrital portion of the sample (*i.e.*, the material that passed through the 0.5 mm sieve) was examined under a compound scope to determine the major components and develop a list of species. The CuNi and stainless steel composites from each site were examined consecutively by the same qualified individual and an immediate comparison of the two samples was made in an effort to reduce the subjectivity of the characterization.

3.3 Objective 3. – Continued Maintenance and Data Management of Existing Water Level Monitoring Station.

Reclamation desired a more permanent configuration of the remote water level monitoring station that was installed at Beal Lake in 2005 (Normandeau 2006). It was necessary to enhance the robustness of the remote monitoring station by installing a more durable (and discreet) housing for the water level sensors on each side of the rock structure. This involved rerouting the data cables

through a permanent underwater and underground conduit, and performing general maintenance on the satellite uplink housing and solar panel.

Hourly water level measurements from either side of the rock structure were obtained from the remote monitoring station, and summarized for 2006.

4.0 RESULTS

4.1 Objective 1. – Determine the effectiveness of the screen system at excluding all life stages of nonnative fishes.

Because of difficulty obtaining eggs and larvae of the desired species, suitable surrogate species having eggs and larvae of similar size and morphology were used (Table 2). Testing at ALDEN occurred over three separate time periods. Specimens from gizzard shad *Dorosoma cepedianum*, used as a surrogate species for threadfin shad, and blue catfish *Ictalurus furcatus*, a surrogate for flathead catfish, were procured and tested from 26 May through 7 June, 2006. Newly emerged smallmouth bass *Micropterus dolomieu* larvae were used as a surrogate for largemouth bass larvae, and were tested on 14 June. We also intended to use smallmouth bass eggs as a surrogate for largemouth bass eggs; however most of the eggs procured had hatched upon arrival, resulting in an insufficient number of eggs for testing. Consequently, fathead minnow *Pimephales promelas* eggs, having nearly the same size and morphology as those of largemouth bass were procured and tested on 24 August.

4.1.1 Fish Exclusion Testing

Gizzard Shad (Small Size Class)

A subset of 30 gizzard shad eggs were randomly selected prior to testing and measured. The eggs averaged 0.5 mm in diameter, and ranged from 0.4 to 0.7 mm (Table 2, Figure 8). Upon hatching, another subset of newly emerged gizzard shad larvae (n = 105) were selected and measured. Shad larvae average 4.2 mm in total length and 0.4 mm head capsule width. All shad larvae were tested between 1 and 5 days following emergence, and still had exposed yolk sacs.

Estimated collection efficiency of the plankton net for gizzard shad eggs was 91% at the lowest slot velocity (0.10 ft/sec) and 75% at the highest slot velocity (0.42 ft/sec). The collection efficiency of shad eggs was not tested at the intermediate slot velocity (0.21 ft/sec) as eggs were observed to be hatching in the sample prior to conducting the evaluation. For gizzard shad larvae, the estimated

Table 2. Three size classes of nonnative species of interest, the surrogate species tested at ALDEN, and average measurements of eggs and larvae of surrogate species.

Size Class	Species of Interest	Surrogate Species	Eggs		Larvae		
			n	width (mm)	n	length (mm)	head capsule width (mm)
Small	Threadfin shad	Gizzard shad	30	0.5	105	4.2	0.4
Medium	Largemouth bass	Fathead minnow (eggs) Smallmouth bass (larvae)	40	1.0	30	8.5	1.7
Large	Flathead catfish	Blue catfish	50	3.8	20	12.1	2.9

collection efficiency for the plankton net was consistently lower than that observed for the eggs. The highest collection efficiency for larvae was 34% at the intermediate slot velocity, followed by 27% at the lowest slot velocity and 19% at the highest slot velocity tested.

Entrainment of gizzard shad eggs was observed at each of the three slot velocities tested (Table 3). Of the 100 eggs released during each trial, 24 eggs were recovered from the plankton net at the lowest slot velocity, 2 eggs were recovered at the intermediate velocity, and 10 eggs were recovered at the highest slot velocity tested. [Due to the small sample size tested, the number of eggs collected at each slot velocity should be interpreted cautiously. A more important observation is that fact that eggs were entrained and recovered at each slot velocity tested]. Of all the eggs recovered, most were found to be still intact and not ruptured; four eggs recovered during the highest slot velocity tested were damaged.

Larvae from gizzard shad were also found to be entrained at each of the three slot velocities tested. Three groups of 100 larvae were released at each slot velocity. The average number of larvae recovered was 29 at the lowest slot velocity, 13 at the intermediate slot velocity, and 20 at the highest slot velocity. All gizzard shad larvae that were recovered from the collection net were dead, and approximately 50% of the specimens were severely damaged (*e.g.*, head capsules missing, ruptured yolk sac).

Smallmouth Bass/Fathead Minnow (Medium Size Class)

Prior to testing, 40 randomly selected fathead minnow eggs were measured. These eggs ranged in diameter from 0.7 to 1.2 mm and averaged 1.0 mm (Table 2). Estimated collection efficiency for fathead minnow eggs in the plankton net was not tested for the lowest slot velocity tested (0.10 ft/sec) but was tested for the higher velocities. The collection efficiency was 90% at the flows generated by

intermediate slot velocity (0.21 ft/sec), and 94% at flows generated during the highest slot velocity (0.42 ft/sec).

Larvae from smallmouth bass were tested 5 days after hatching. These larvae averaged 8.5 mm in total length (ranging 8.1 to 9.1 mm), and 1.7 mm head capsule width (ranging 1.6 to 2.1 mm). The collection efficiency of smallmouth bass larvae was tested at the lowest and highest slot velocities tested. Of the 100 larvae released directly upstream of the plankton net, 66% were collected at the lowest slot velocity, and 92% were collected at the highest slot velocity.

Entrainment was not detected for fathead minnow eggs or smallmouth bass larvae at any of the three slot velocities tested (Table 3). When fathead minnow eggs were released from the injection system, they slowly drifted over the top of the screen surface. Most of the eggs were loosely impinged on the surface of the screen, but as many as 30% of the eggs slowly rolled down the sides of the screen and eventually fell off. Smallmouth bass larvae were also released over the surface of the screen. At all slot velocities tested, most individuals exhibited positive rheotaxis and actively resisted impingement upon contact with the screen. Less than about 20% of the larvae were impinged or otherwise present on or near the screen within two minutes of release.

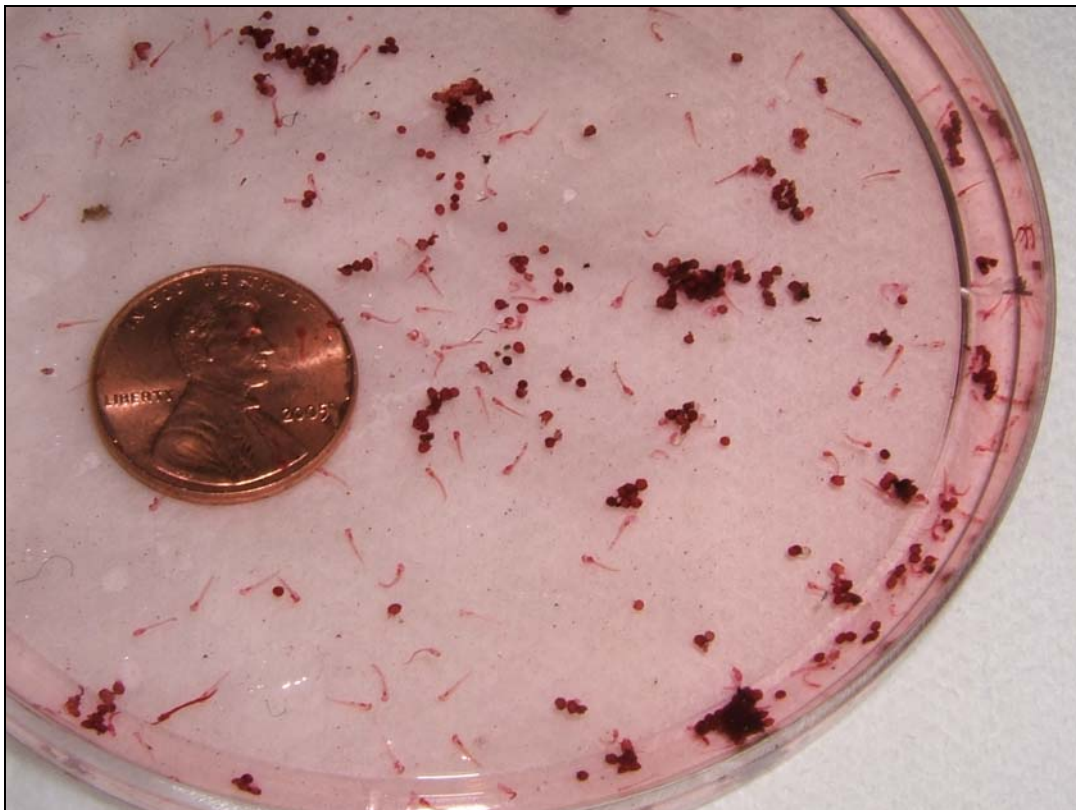

Figure 8. Size perspective of gizzard shad eggs and newly emerged larvae

Blue Catfish (Large Size Class)

A subset of 50 blue catfish eggs were measured and averaged 3.8 mm in diameter with a range from 3.1 to 4.7 mm (Table 2). Blue catfish larvae were measured and tested 1 day following emergence. The larvae averaged 12.1 mm in total length and 2.9 mm head capsule width (n = 30; Figure 9).

Collection efficiency of blue catfish eggs was 99% at the lowest slot velocity tested. For blue catfish larvae, estimated collection efficiency was 23% at the lowest slot velocity tested, 46% at the intermediate slot velocity and, 94% at the highest slot velocity.

Neither the eggs nor the larvae of blue catfish were entrained through the wedge-wire screen at any of the three slot velocities tested (Table 3). The larger surface area of the blue catfish eggs appeared to result in a higher rate of impingement when compared to the smaller fathead minnow eggs. At all slot velocities tested, approximately 80% of the released blue catfish eggs remained on the surface to the screen for the duration of the test; eggs that eventually rolled over the edge of the screen, lost contact with the screen surface only after they reached the bottom. Similarly, the larger blue catfish larvae became more easily impinged on the screen surface when compared to the smallmouth bass larvae. Unlike the eggs however, the blue catfish larvae were able to propel themselves along the surface and down the edge of the screen. Consequently, nearly all larvae released eventually became free of the screen surface less than 3 minutes following release.

Table 3. Dichotomous classification of entrainment for the three size classes of eggs and larvae tested at the ALDEN in 2006.

Size Class ^a	Slot Velocity	Eggs	Larvae
Small	0.10	YES	YES
	0.21	YES	YES
	0.42	YES	YES
Medium	0.10	NO	NO
	0.21	NO	NO
	0.42	NO	NO
Large	0.10	NO	NO
	0.21	NO	NO
	0.42	NO	NO

^a Species used to represent each size class are summarized in Table 2.



Figure 9. Size perspective of newly emerged blue catfish larvae.

4.2 Objective 2. – Evaluate the Effectiveness of the antibiofouling screen material in inhibiting biological growth.

Frames that supported the test coupons were initially deployed at each test location on 7 April, 2006. Three subsequent sampling intervals occurred in June, September and November (Table 4). The number of days between sampling intervals ranged from 69 to 78 days.

4.2.1 Visual Observations

Beal Lake

Overall, comparatively little organic material was visible on the CuNi screen coupons during all of the sampling intervals at Beal Lake. The fouling that did occur consisted mostly of attached insect larvae and pupa (primarily chironmid) and inorganic material. This material was easily removed with light scrubbing.

In general, the stainless steel did not perform as well as the CuNi coupons, although the amount and

type of fouling material differed among sampling periods. In June, the stainless steel coupons were enveloped with thick mats of green filamentous algae (mainly *Cladopora spp.*), which entrapped silt and debris, and formed a thick gelatinous mixture that completely covered the entire surface of the coupons (Figure 10). In September, visual observations indicated that the stainless steel coupons also had more biofouling than the CuNi samples. However, during this sampling period, the screen coupons were covered predominately with large mats of cyanobacterial dominated by *Tolypothrix spp.* rather than filamentous algae. These mats were also embedded with silt and debris, and formed a thick gelatinous layer over the entire surface of the coupons. This layer provided a substrate for aquatic invertebrates to inhabit. In November, the amount of biofouling material on the stainless steel coupons appeared to be less than observed during the earlier sampling intervals, and consisted mainly of attached insect larvae and pupa. The taxonomic composition of the invertebrates recovered from the screen samples are presented in Appendix B.

Martinez Lake

Similar to the samples at Beal Lake, the CuNi coupons remained generally free of any biofouling material over the duration of the study. They required only minimal scrubbing to remove thin layer of sediment buildup and attached invertebrate cases.

Similar to what was observed at Beal Lake, the stainless steel coupons deployed at Martinez Lake had extensive biofouling when compared to the CuNi screen coupons. The primary biofouling agent for all sample intervals consisted of dense detrital/microbial mats that formed thick gelatinous substrate with heavy sediment buildup over the entire surface of the test coupons (Figure 10). As observed at Beal Lake, attached insect larvae and pupa and other invertebrates were also prevalent on all of the stainless steel screens. However, unlike the samples at Beal Lake, the amount of biofouling did not appear to decrease in November on samples deployed at Martinez Lake when compared to June and September samples; the extent of biofouling remained visibly dissimilar compared to the CuNi coupons throughout the duration of the study.

Table 4. Study start dates (date screens were deployed) and subsequent sampling dates in 2006. Numbers in parentheses indicate the number of days between each sampling period.

Site	Initial deployment		First sampling/ Redeployment		Second sampling/ Redeployment		Final sampling
Beal Lake	April 7	(74)	June 20	(78)	September 6	(69)	November 14
Martinez Lake	April 7	(75)	June 21	(78)	September 5	(71)	November 15

4.2.2 Ash Free Dry Mass (AFDM)

Individual Kruskal-Wallis tests revealed that AFDM differed significantly between alloys ($P < 0.001$), test locations ($P = 0.005$), and among sampling intervals ($P < 0.001$). Further statistical analysis indicated that when AFDM values were compared within each sampling interval by location, only those samples collected in November indicated a significant location effect ($P < 0.001$); those collected in June ($P = 0.636$) and September ($P = 0.365$) did not indicate a location effect. Consequently, AFDM data collected in June and September were pooled by location for the purpose of comparing alloys, while AFDM data collected in November were appropriately separated by location. Results of these comparisons indicated that a significantly higher amount of material was found on the stainless steel coupons when compared to the CuNi coupons during June ($P < 0.001$) and September ($P < 0.001$). In November, a significantly higher amount of material was found on the stainless steel coupons when compared to the CuNi coupons at the Martinez Lake site ($P = 0.002$), but no significant difference was found between alloys at Beal Lake ($P = 0.384$, Figure 11).

4.2.3 Water Quality

Daily water temperatures recorded at each test location were similar, and generally increased throughout the spring and early summer and decreased during late summer and fall (Figure 12). However, average daily water temperatures at Beal Lake were typically 2 to 3 degrees warmer in the spring and early summer, and were 2 to 6 degrees cooler in the fall when compared to the average water temperatures recorded at Martinez Lake. Maximum daily water temperature was recorded at both locations during the third week in July; maximum water temperature at Beal Lake was 91° F and at Martinez Lake was 89° F. At both locations, water temperatures decreased precipitously in late September when water temperatures decreased by nearly 10 degrees in approximately 6 days.

Water quality data including dissolved oxygen, specific conductivity, pH, salinity, and turbidity collected as a part of each sampling episode were generally consistent between locations, but varied among sampling periods (Table 5). Measurements collected during the spring and early summer were characteristic of those typically found in eutrophic water bodies during peak biological activity and increasing water temperatures. In general, turbidity at both locations was high as indicated by low Secchi disk readings. Dissolved oxygen levels were near or below 50% saturation, pH was slightly alkaline, and specific conductance was comparatively low.

Table 5. Water quality data recorded during each sampling period for biofouling at Beal Lake and Martinez Lake, Arizona, 2006.

Site	Sample		Secchi depth (in)	pH	DO (%)	DO (mg/l)	Conductivity	Specific conductivity	Temperature (F)	Salinity (ppt)
	date	time								
Beal Lake	4/7/06	12:54	48	8.0	40.0 - 45.0	4.1	1,330	1,467	68.2	0.7
Martinez Lake	4/7/06	17:54	60	7.8	56.3 - 59.0	5.4	1,074	1,241	64.4	0.6
Beal Lake	6/20/06	12:30	47	7.8	59.6 - 64.0	4.7 - 4.9	1,523	1,436	82.8	0.7
Martinez Lake	6/21/06	12:32	78	7.9	42.2 - 46.9	3.3 - 3.5	1,272	1,208	82.4	0.6
Beal Lake	9/7/06	11:14	60+	9.0	54.3 - 61.6	4.0 - 5.0	1,488	1,305	90.3	0.6
Martinez Lake	9/5/06	10:26	76	8.0	49.2 - 51.8	3.9 - 4.1	1,321	1,205	86.2	0.6
Beal Lake	11/14/06	11:36	60+	7.9	66.2 - 67.4	6.7 - 6.9	1,666	2,076	58.5	1.1
Martinez Lake	11/15/06	12:02	114	8.2	40.2 - 41.4	3.8 - 4.1	995	1,178	62.4	0.6



Figure 10. Biofouling of test coupons prior to cleaning at Beal Lake (A) and Martinez Lake inlet canal (B) for sample interval April – June.

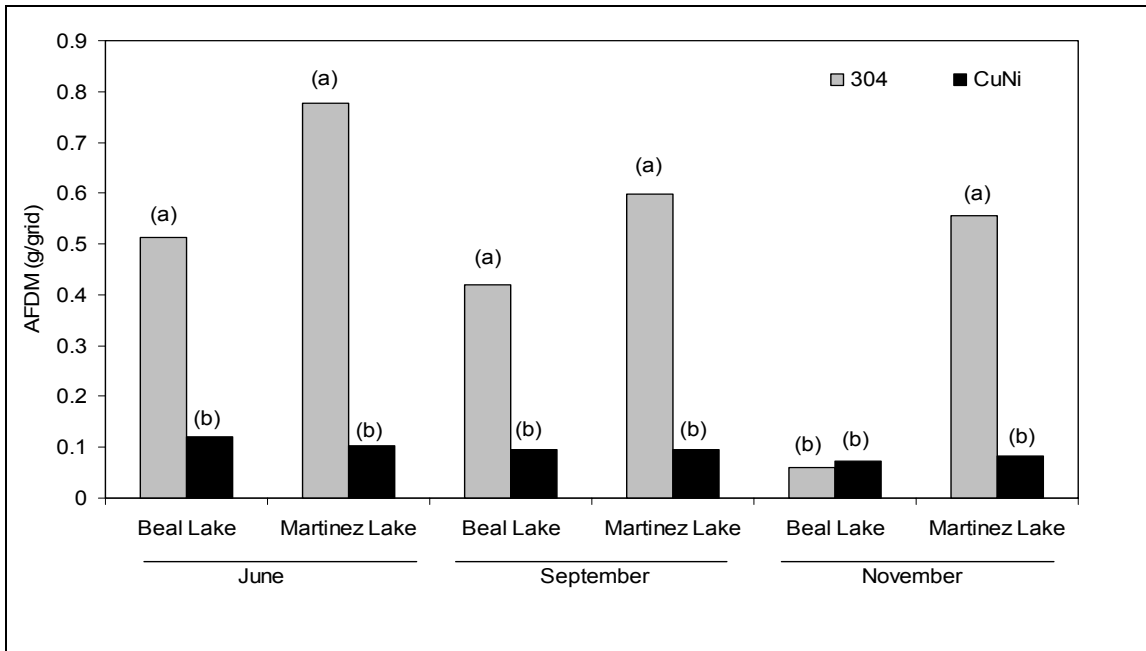

Figure 11. Ash Free Dry Mass (AFDM) averaged by screen type at each location during each sampling period. Significant differences ($p < 0.05$) are indicated by different alphabetic superscripts.

The most notable difference in water quality between locations occurred in November. At both locations water clarity was higher than observed earlier in the year, although the specific conductance at Beal Lake was nearly twice that observed at Martinez Lake. In addition, dissolved oxygen concentrations were considerably higher at Beal Lake (66.2 – 67.4%) than at Martinez Lake (40.2 – 41.4%).

4.3 Objective 3. – Continue maintenance and data management of existing water level monitoring station.

A more permanent installation of the existing remote water level monitoring system was constructed at Beal Lake on 3 April, 2006. This involved enhancing the robustness of the remote monitoring station by installing a permanent housing for the water level sensors on each side of the rock structure. Two 6-foot sections of 4-inch diameter UV resistant Acrylonitrile Butadiene Styrene (ABS) pipes (schedule 60) were secured vertically in 20 gallon utility tubs filled with concrete. Once secured, the units were submerged in the water at a distance of approximately 15 ft from either side of the rock structure. The data cables leading from each water level sensor (housed in the ABS pipe) to the satellite relay were rerouted through permanent underwater and underground conduits for

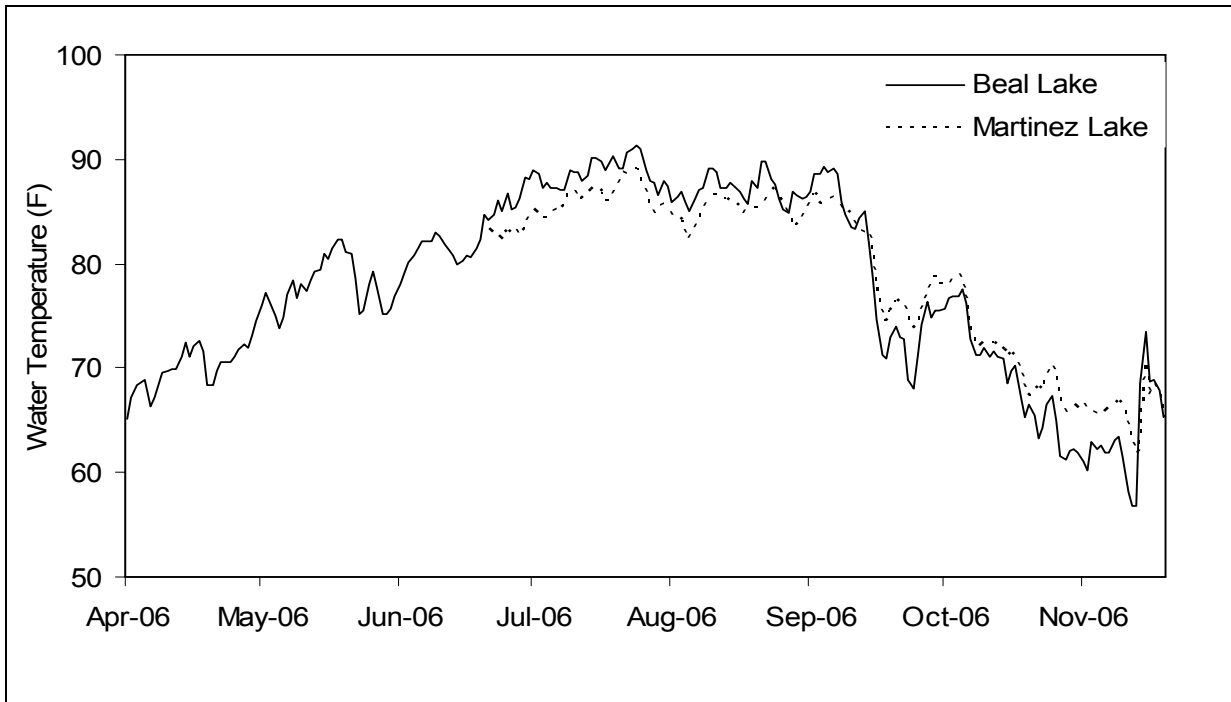

Figure 12. Mean daily water temperatures recorded at each biofouling test site from April through November, 2006.

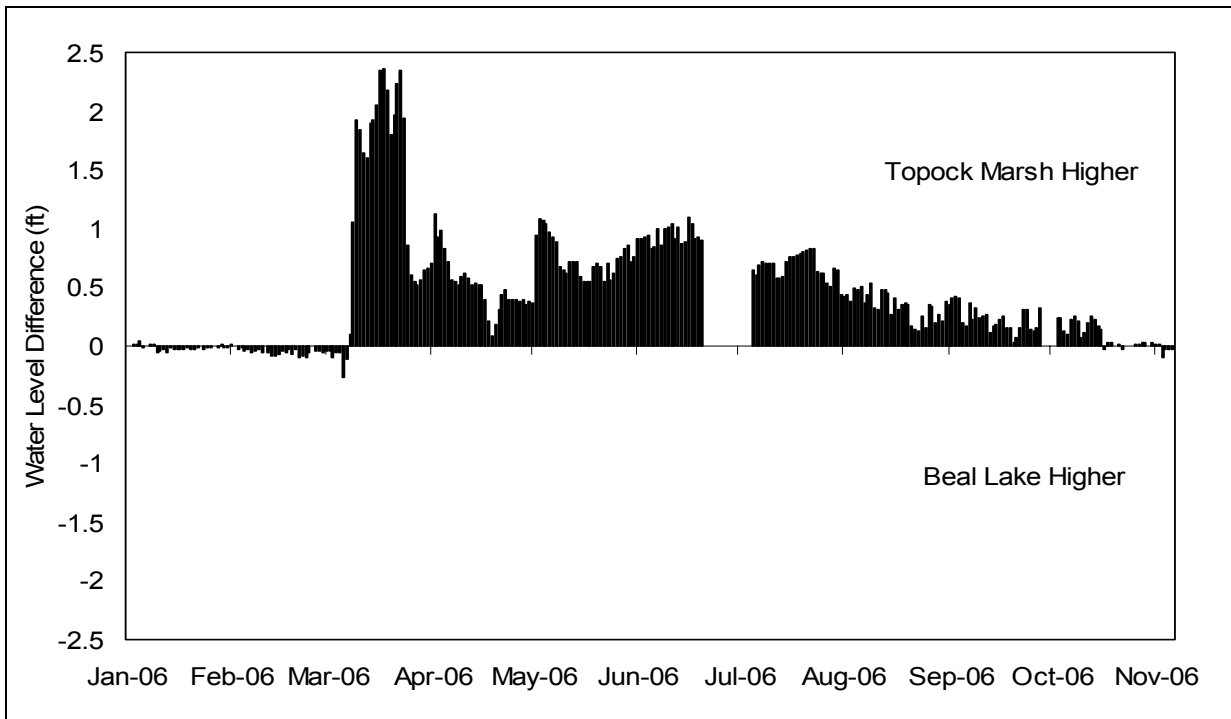

Figure 13. Mean daily water level differences between Topock Marsh and Beal Lake, 2006. Water level differences from 21 June to 4 July were removed from analysis.

improved durability and safety. For additional safety, a floating marker buoy was attached to the top of each permanent housing.

Water levels on either side of the rock structure were monitored through 2006. From January through early March, water levels remained near equilibrium on either side of the rock structure (Figure 13; Appendix C). Beginning in mid-March, the valves in the screen system were closed and Beal Lake was drawn down to facilitate management efforts to remove nonnative fishes using rotenone. Beal Lake was maintained below normal water levels throughout April. Water flow was restored by early May, although water levels in Beal Lake remained approximately 0.5 to 1.0 ft lower than Topock Marsh throughout the summer and early fall. Water levels on either side of the rock structure did not return to equilibrium until late October.

5.0 DISCUSSION

Two research objectives were established to further evaluate the prototype screen system at Beal Lake in 2006. The first objective was to determine the efficiency of the screen system at excluding all life stages of nonnative fishes. The second research objective was to continue to evaluate the effectiveness of the anti-biofouling screen material at inhibiting biological growth. A further management objective was to continue monitoring water levels on either side of the rock structure, and provide technical service to the remote monitoring station at Beal Lake.

Our findings suggest that threadfin shad eggs and larvae are capable of passing through a wedge-wire screen with a slot width of 0.6 mm, such as those installed at Beal Lake. We found that both gizzard shad eggs and larvae were entrained through the screen system at all water velocities tested. Based on the relative size of the eggs and larvae compared to the slot width of the screen, these results are consistent with findings from previous entrainment studies. For instance, Weisberg et al. (1987) found that fish larvae up to 10 mm in length were entrained through a wedge-wire screen having a slot width of 1 mm, and suggested that the slot width should be approximately 10% of a fish's length to prevent entrainment. Similar characterizations have been made regarding entrainment of fish eggs. A recent evaluation of wedge-wire screens installed in the Chesapeake Bay reported entrainment of fish eggs through a slot width less than 50% of the egg's diameter (EPRI 2006). While our results indicate that threadfin shad eggs and larvae are capable of being entrained, the biological significance of these results should be considered.

Under natural conditions, threadfin shad are broadcast spawners; their eggs are demersal and adhesive, adhering to aquatic vegetation and other objects throughout incubation (Lambou 1965).

Since the eggs are not pelagic, the potential for them to come into contact with the screen surface and be entrained is limited. In contrast, newly emerged shad larvae are pelagic and are therefore more likely to come into contact with the screen and be entrained. It is important to note however, all shad larvae recovered in the plankton net following entrainment were dead, and approximately half were missing head capsules. Since most of the larvae that were recaptured during the control releases to estimate collection efficiency were recovered alive, we suspect that the observed damage occurred as a result of entrainment. Newly emerged larvae have been shown to be highly susceptible to entrainment related mortality (Marcy et al. 1978). Their underdeveloped skeleton, musculature, and integument are soft and provide limited mechanical protection to vital organs. Consequently, while newly emerged threadfin shad may pass through the screen structure, it is likely that most, if not all, would be killed during the process.

While this information should be considered, it may be prudent that further management decisions regarding the use of 0.6 mm wedge-wire screens should be made with the knowledge that they do not exclude all life stages of threadfin shad. One possible management action that could be implemented is to close the screens during periods of threadfin shad spawning and early larval emergence.

Threadfin shad have been shown to initiate spawning at water temperatures as low as 57° F (Rawstron 1964), but are typically known to spawn between 68° F and 79° F (Kimsey and Fisk 1964; Moyle 1976). At Beal Lake, these temperatures generally occur between April and early May, and prior to the period of highest evapotranspiration rates (June- August; BOR 2003). Closing the valves and preventing water from passing through the screens during this time period would minimize the risk of shad being entrained.

Another possible management approach would be to allow threadfin shad to penetrate the screen system and co-exist with native species. The biological significance of this situation may not be completely detrimental to the native fishes. For instance, some native fishes such as bonytail chub are omnivorous, feeding on a variety of insects, plants and fish (Mueller 2006). In water bodies containing only native species, threadfin shad could provide a critical food source for larger chub. However, the benefits of threadfin shad as a potential prey source for mature native fish may be outweighed by the potential competition for food resources utilized by young-of-year native species. Also adult threadfin shad have been shown to be limited predators on newly emerged native species (Mueller et al. 2005b)

We found no other evidence that the remaining species tested were entrained. These results suggest that the screen system does successfully prevent the passage of eggs exceeding approximately 1 mm

in diameter or larvae larger than about 6 mm in length. Exclusion of eggs and larvae of this size may be critical to the long-term success of self-sustaining populations of native fishes as larger species, such as largemouth bass, have been shown to voracious predators on native species (Mueller et al. 2005b). At the lowest slot velocities tested, larger eggs and larvae were seen contacting the screen and then either rolling or propelling themselves off the screen surface. Only at the highest slot velocity tested did we observe larger eggs and larvae becoming slightly impinged on the screen surface.

Overall, the results of the biofouling evaluation clearly show an advantage to using CuNi alloy as a screen material rather than stainless steel. At both test locations, the CuNi coupons were very effective at resisting biofouling. The biofouling that did occur on the CuNi coupons was easily removed and did not cause blockage of the interstitial screen space. The CuNi material resisted the growth of filamentous algae and cyanobacteria that was most frequently found on the stainless steel coupons. While the CuNi material is initially more expensive, the resistance to biofouling could substantially reduce the costs associated with maintenance and downtime, and could increase overall system efficiency, potentially offsetting initial higher costs.

The amount and type of biofouling that occurred on the stainless steel coupons varied among sampling periods, particularly for those deployed at Beal Lake. At Beal Lake, we found a higher occurrence of filamentous algae on the samples collected in June where, as in September, we found a higher occurrence of bacteria. These results are typical of an aquatic system as biomass shifts from photosynthetic organisms in spring and early summer as water temperatures increase, to consuming or decaying organisms later in the year. Interestingly, the stainless steel coupons were virtually devoid of biofouling material in November at Beal Lake, unlike those at Martinez Lake. The reason for this is unclear, but it may be attributed to an earlier or more rapid die-off rate of aquatic vegetation at Beal Lake in the fall. This earlier die-off rate at Beal Lake is likely associated with cooler water temperatures and is apparent from differences in water quality when compared to Martinez Lake.

Even though CuNi was found to be an effective anti-biofouling agent, we still recommend that the screens are routinely cleaned; particularly to remove floating debris that becomes impinged on the screen surface. Floating organic material and aquatic macrophytes were consistently present on all test coupons and the PVC frame. Similar observations were made at the screens installed at Beal Lake. Large mats of floating algae were found impinged against the screens and appeared to cause interruption of flow. Blocked areas on the screens could contribute to poor hydraulic performance

and may create areas of increased slot velocity along the screen surface. These areas of increased velocity or “hot spots” may increase the slot velocity through the screen higher than velocities tested, and thus increasing the potential for larger ichthyoplankton of being entrained.

It is unclear why there was a consistent difference in water levels on either side of the rock structure throughout the summer. One possible explanation may be related to the renovation effort conducted in the spring at Beal Lake. During the renovation, the surface water elevation in Beal Lake was lowered to facilitate the application of rotenone, and surface water flow was not restored to Beal Lake until early May and the beginning of the peak evapotranspiration period. As a result, Beal Lake filled more slowly, and remained lower than Topock Marsh throughout the summer and did not fully recover until the fall when air temperatures and evaporation rates decreased. Another possible effect contributing to the slow refill rate may be attributed to subsurface flow from Beal Lake. In the summer, the water surface elevation of Beal Lake is generally higher than the Colorado River. This may increase the amount of subsurface flow from the lake to the river. One or a combination of these effects may have resulted in the water levels remaining lower in Beal Lake than in Topock Marsh throughout the summer.

The results of this Phase II evaluation, when combined with the data collected during Phase I in 2005 (Normandeau 2006), suggest that the use of the cylindrical wedge-wire screens is a management tool that can be used to help maintain or establish predator-free backwaters. The biological significance of passage of some eggs and larvae of the smallest fish tested should be investigated and, if it is shown to be a biological problem, further management actions should be taken. The lack of entrainment of ichthyoplankton from larger predatory species is encouraging. The evaluation of the anti-biofouling characteristics of the screen material installed at Beal Lake showed that the CuNi alloy screens significantly outperformed the standard screen material and justified any additional expense incurred in the initial screen installation. If Reclamation is considering additional screen installations where biofouling is a concern, the anti-biofouling alloy should be used.

6.0 Literature Cited

- BOR (Bureau of Reclamation). 2003. Lower Colorado River Accounting System — Calendar Year 2003. Bureau of Reclamation, Lower Colorado Region, Boulder City, NV.
- Dill, W.A. 1944. The fishery of the lower Colorado River: California Fish and Game. 30:109-211.
- Eaton A.D., L.S. Clesceri, E.W. Rice, and A.E. Greenberg. 2005. Standard Methods for the Examination of Water and Wastewater, 21st Edition. American Public Health Association, American Water Works Association & Water Environment Federation.
- EPRI. 2006. Field Evaluation of Wedgewire Screens for Protecting Early Life Stages of Fish at Cooling Water Intake Structures. Prepared by Alden Research Laboratory, Inc., EPRI Report No. 1012542.
- Fradkin, P.L. 1981. A river no more: the Colorado River and the West. University of Arizona Press, Tucson.
- Hanson, B. N., W. H. Bason, B. E. Beitz, and K. E. Charles. 1978. A practical intake screen which substantially reduces the entrainment and impingement of early life stages of fish. *In: Fourth National Workshop on Entrainment and Impingement, December 5, 1977. Chicago, IL. L.D. Johnson (ed.)*
- Hanson, B. N. 1981. Studies of Larval Striped Bass (*Morone saxatilis*) and Yellow Perch (*Perca flavescens*) Exposed to a 1 mm Slot Profile-wire Screen Model Intake. *In: Advanced Intake Technology for Power Plant Cooling Water Systems, April 22-24, 1981.*
- Kimsey, J. B. and L. O. Fisk. 1964. Freshwater nongame fishes of California. California Department of Fish and Game.
- King, K.A., D.L. Baker, W.G. Kepner, and C.T. Martinez. 1993. Trace elements in sediment and fish from national wildlife refuges on the Colorado River, Arizona. U.S. Fish and Wildlife Service, Arizona Ecological Service Office, Phoenix, Arizona.
- Lambou, V.W. 1965. Observations on the size distribution and spawning behavior of threadfin shad, Transactions of the American Fisheries Society 94(4):385-386.
- Lifton, W. 1979. Biological Aspects of Screen Testing on the St. Johns River, Palatka, Florida. *In: Passive Intake Screen Systems Workshop, Chicago, IL, December 1979.*
- Love, K.W., and C. Vizcarra. 2000. Semi-permeable fish control structure and pump station design. Prepared for the United States Bureau of Reclamation, and Department of Civil and Environmental Engineering.
- Marcy, B.C., A.D. Beck, and R.E. Ulanowicz. 1978. Effects and impacts of physical stress on entrained organisms. Pages 136-188 *in Power Plant Entrainment: A Biological Assessment.* Academic Press, New York, NY.
- Marsh, P.C., and C.A. Pacey. 2005. Immiscibility of native and nonnative species. Pages 59-63 *in Restoring native fish to the Lower Colorado River: interactions of native and nonnative*

- fishes. U.S. Fish and Wildlife Service, Albuquerque, New Mexico, and U.S. Bureau of Reclamation, Boulder City, NV.
- Meffe, G.K. 1985. Predation and species replacement in American southwest fishes: a case study. *The Southwest Naturalist* 30:173-187.
- Minckley, W. L. and J. E. Deacon. 1968. Southwestern fishes and the enigma of “endangered species.” *Science* 40:1421-1432.
- Minckley, W. L. 1983. Status of the razorback sucker, *Xyrauchen texanus* (Abbott), in the lower Colorado River basin. *The Southwestern Naturalist* 28(2):165-187.
- Minckley, W. L. 1991. Native fishes of the Grand Canyon region: an obituary? Pages 124-177 in *Colorado River ecology and dam management*. National Academy Press, Washington D.C.
- Moyle, P. B. 1976. *Inland fishes of California*. University of California Press, Berkeley, CA.
- Mueller, G.A. 2005a. Predatory fish removal and native fish recovery in the Colorado River mainstem: what have we learned? *Fisheries* 30 (9) 10-19.
- Mueller, G.A., J. Carpenter, and P.C. Marsh. 2005b. Cibola high levee pond annual report, 2004: U.S. Geological Survey, Biological Resources Discipline, open-file report 2005-1075.
- Mueller, G.A. 2006. Ecology of bonytail and razorback sucker and the role of off-channel habitats in their recovery: U.S. Geological Survey Scientific Investigations Report 2006-5065.
- Otto, R. G., T. I. Hiebert, and V. R. Kranz. 1981. The Effectiveness of a Remote Profile-Wire Screen Intake Module in Reducing the Entrainment of Fish Eggs and Larvae. In: *Proceedings of the Workshop on Advanced Intake Technology*, San Diego, CA, April 1981. P. B. Dorn and J. T. Larson (Eds.).
- Normandeau (Normandeau Associates Inc.). 2006. Evaluation of a cylindrical wedge-wire screen at Beal Lake, Arizona, 2005. Prepared by Normandeau Associates Inc. for the Bureau of Reclamation, Lower Colorado Region, Boulder City, NV.
- Rawstron, R. R. 1964. Spawning of threadfin shad, *Dorosoma petenense*, at low water temperatures. *California Fish and Game* 50(1):58.
- Weisberg, S.B., W.H. Burton, F. Jacobs, and E.A. Ross. 1987. Reductions in ichthyoplankton entrainment with fine-mesh, wedge-wire screens. *North American Journal of Fisheries Management* 7:386-393.
- Zar, J.H. 1984. *Biostatistical analysis*, 2nd edition. Prentice-Hall, Englewood Cliffs, New Jersey.

APPENDIX A

Cylindrical wedge-wire screen drawing and specifications.

D-96714-0

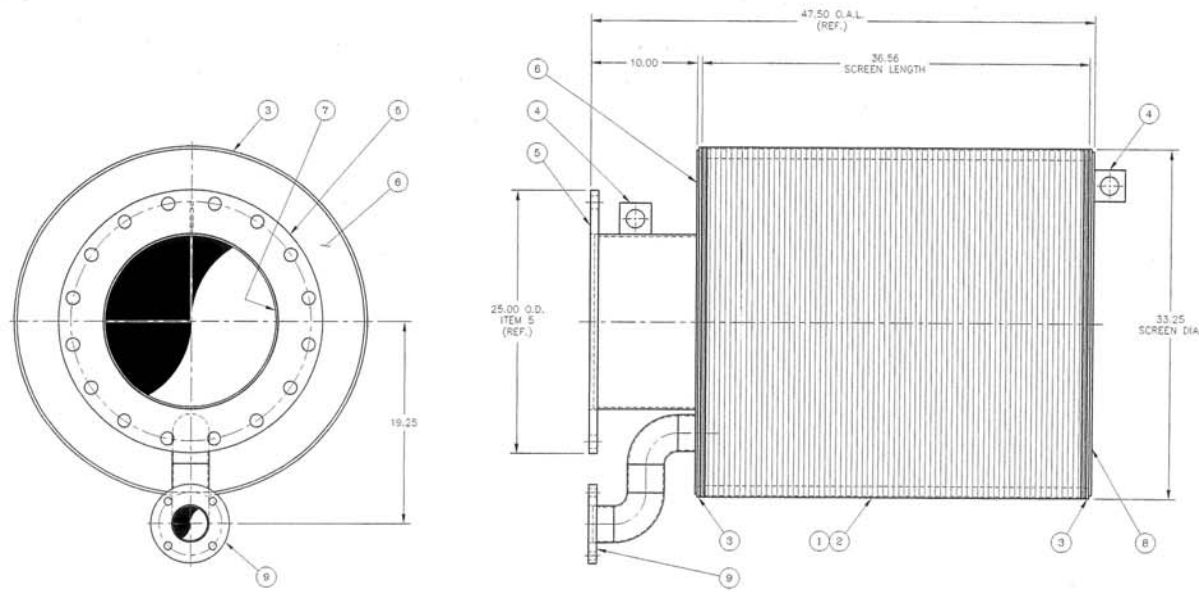

S-33X18 (H.C.) INTAKE SCREEN ASSEMBLY

MATERIAL LIST		
ITEM QTY	DESCRIPTION	MATERIAL
SCREEN:		
1	WIRE 2" W/ SLOT x 0.004	ZAL
2	ROD	ZAL
3	WELD RING	ZAL
4	LIFTING LUG	ZAL
5	FLANGE FLANGE 0.75 THK TO MAKE WITH 18" B.W.K. C-207 TABLE 2 CLASS D	ZAL
6	TRANSITION PLATE	ZAL
7	OUTER FLOW MODIFIER TUBE	ZAL
8	END PLATE	ZAL
9	ABW FLANGE 0.75 THK TO MAKE WITH 5" AND 150#	ZAL

- CUSTOMER NOTES:**
- 1) CAPACITY 1500 GPM @ 0.5 ft/sec MAXIMUM THRU SLOT VELOCITY.
 - 2) 8ft. DIFFERENTIAL COLLAPSE PRESSURE.
 - 3) ESTIMATED WEIGHT = 475 lbs.
 - 4) SCREEN OPEN AREA = 29.63%

FOR APPROVAL
Customer Acknowledgment

any changes after approval by customer or customer's agent will be at the customer's expense unless Johnson's agent otherwise agrees in writing. Acceptance of these terms is confirmed by the signature below.

Approved as is - PROCEED TO MANUFACTURE

Change per comments - RESUBMIT FOR APPROVAL (May affect delivery and price)

Accepted as noted-Proceed to Manufacture

Signed _____ Dated _____

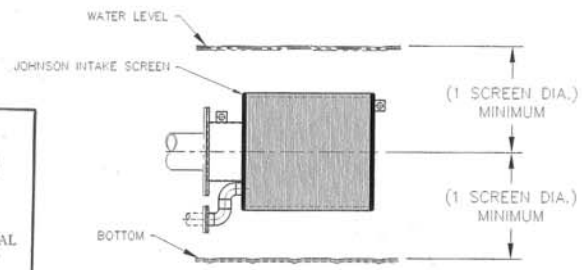

TYPICAL INSTALLATION & ORIENTATION

REV.	DESCRIPTION	BY	DATE	APP.
<p>THIS DRAWING AND DESIGN ARE THE PROPERTY OF JOHNSON SCREENS. IT SHALL BE KEPT AND USED ONLY FOR THE PURPOSE AND PROJECT SPECIFIC BY WHICH IT WAS DESIGNED. IT SHALL BE RETURNED TO JOHNSON SCREENS UPON COMPLETION OF THE PROJECT.</p> <p>DO NOT SCALE THIS DRAWING</p> <p>WORK TO DIMENSIONS</p> <p>LINEAR DIMENSIONS ARE IN INCHES</p> <p>THIRD ANGLE PROJECTION</p> <p>MINIMUM FINISHES HEIGHT IN UNLESS OTHERWISE SPECIFIED</p>				
<p>S-33X18 (H.C.) INTAKE ASSEMBLY W/3" AIR BACKWASH SYSTEM</p> <p>U.S. DEPT. OF THE INTERIOR BEAL LAKE, AZ.</p> <p>Johnson screens™ A Weatherford Company St. Paul, Minnesota 55164-0118</p>				
DATE	D. WICKVILLE	10/17/04	PATENT No. 6,051,131	
DESIGN	BY			
CHECKED	BY	10/17/04	SHEET 1 OF 1	
APPROVED	BY	10/17/04	D-96714-0	

Appendix A. Cylindrical wedge-wire screen drawing and specifications.

APPENDIX B

Taxonomic composition of invertebrates found on the screen samples at each test location and among sampling periods.

Appendix B. Taxonomic composition of invertebrates found on the screen samples at each test location and among sampling periods, 2006.

Taxonomic Composition				Fouling Type	June				September				November			
					Beal Lake		Martinez		Beal Lake		Martinez		Beal Lake		Martinez	
Phylum	Class	Order	Family		304	CuNi	304	CuNi	304	CuNi	304	CuNi	304	CuNi	304	CuNi
Porifera	Demospongiae	Haplosclerida	Spongillidea	Attached	X	X	X		X		X	X				
Bryozoa	Phylactolaemata	Plumatellida	Plumatellidae	Attached					X	X			X	X		
Annelida	Oligochaeta	Haplotaxina	Sparganophilidae	Attached							X				X	
Mollusca	Gastropoda	Basommatophora	Ancylidae	Motile											X	X
Mollusca	Gastropoda	Basommatophora	Physidae	Motile			X		X	X			X	X	X	
Mollusca	Gastropoda	Basommatophora	Planorbidae	Motile											X	
Mollusca	Bivalvia	NA	Sphaeriidae	Attached	X					X					X	
Arthropoda	Malacostraca	Amphipoda	Gammaridae	Motile			X	X								
Arthropoda	Malacostraca	Amphipoda	Hyalellidae	Motile					X	X					X	X
Arthropoda	Insecta	Diptera	Chironomidae	Attached	X	X		X	X	X	X	X	X	X	X	X
Arthropoda	Insecta	Diptera	Ceratopogonidae	Attached					X		X					X
Arthropoda	Insecta	Ephemeroptera	Caenidea	Motile	X	X			X	X	X	X	X	X	X	X
Arthropoda	Insecta	Neuroptera	Sisyridae	Attached			X			X					X	
Arthropoda	Insecta	Trichoptera	Hydroptilidae (larvae)	Motile											X	X
Arthropoda	Insecta	Trichoptera	Hydroptilidae (pupae)	Attached			X	X							X	X
Arthropoda	Insecta	Trichoptera	uid larvea	Motile	X	X	X	X	X	X	X	X	X			
Arthropoda	Insecta	Trichoptera	uid pupae	Attached					X	X	X	X				
Arthropoda	Insecta	Odonata	Zygoptera	Motile	X	X	X	X	X	X	X	X	X		X	X
Arthropoda	Insecta	Odonata	Anisoptera	Motile	X					X	X				X	
Entoprocta	Other	Entoprocta	Umatellidae	Attached	X	X	X	X	X	X	X	X	X	X		
Arthropoda	Arachnida	Hydrachnida	Hydrachnidae	Motile	X		X	X	X	X	X	X			X	
Platyhelminthes	Turbellaria	NA	NA	Motile											X	

APPENDIX C

Monthly summary of water level differentials between
Beal Lake and Topock Marsh, 2006.

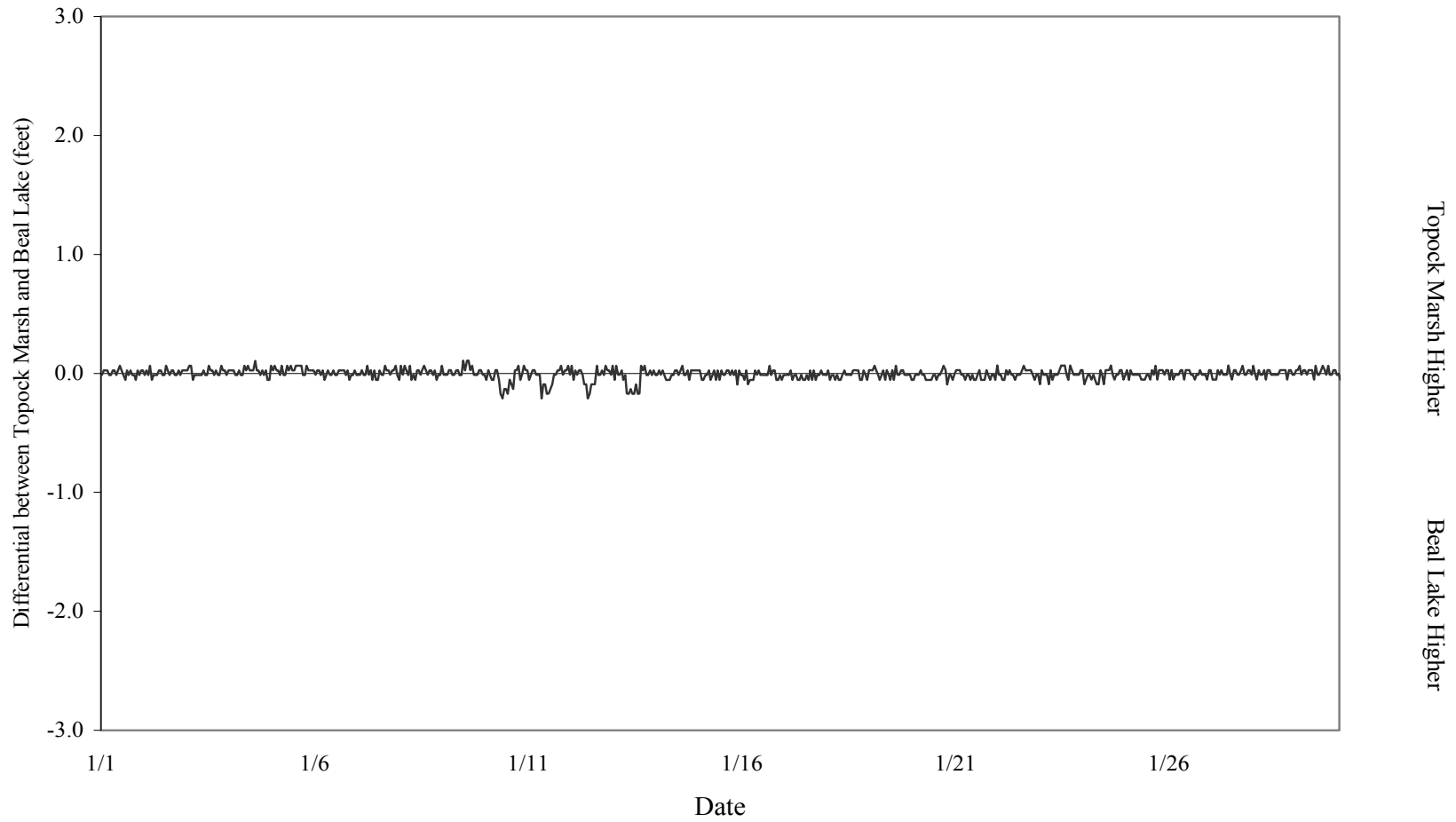

Appendix Figure C-1. Water level differential between Beal Lake and Topock Marsh, January 2006.

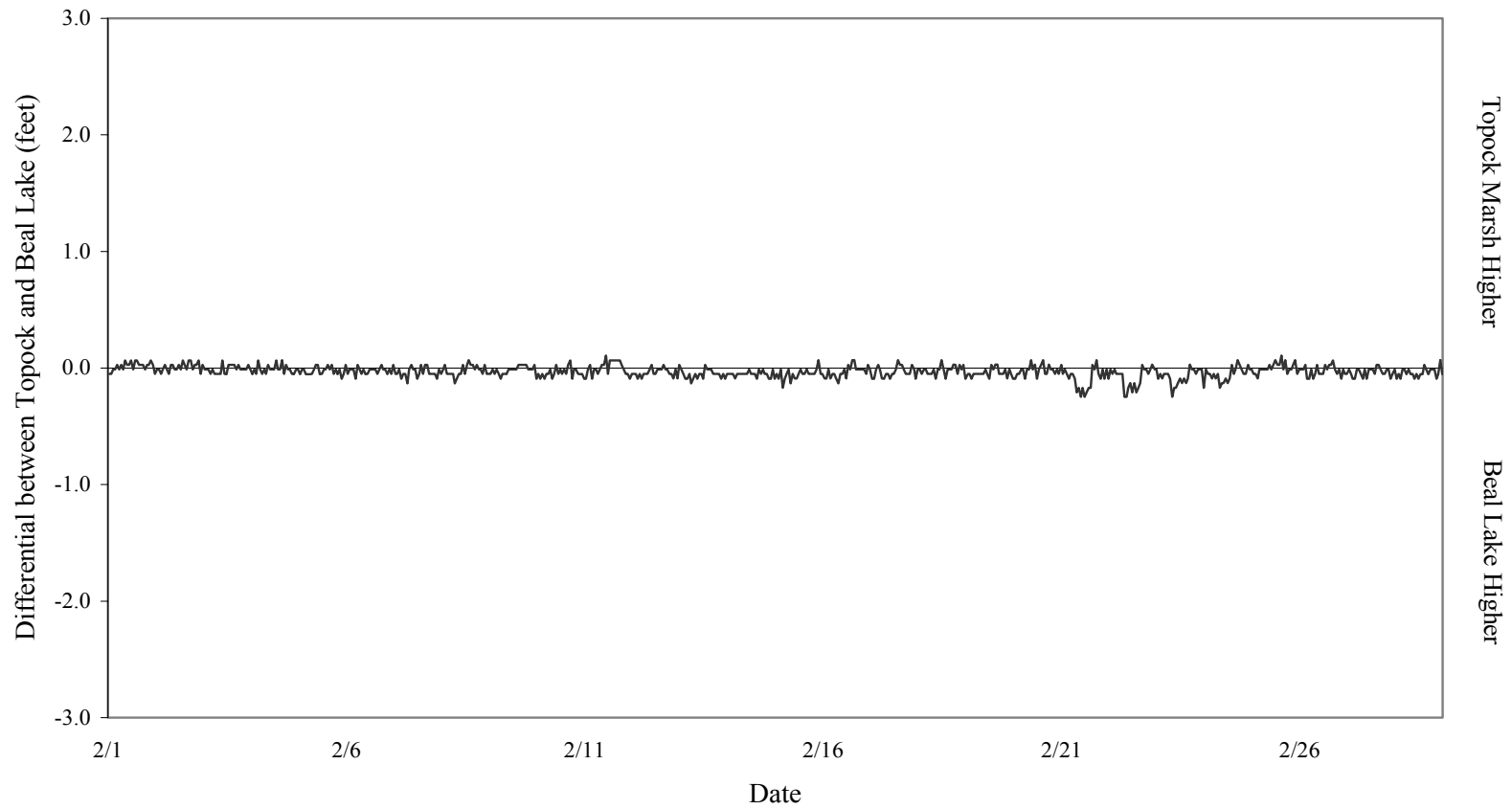

Appendix Figure C-2. Water level differential between Beal Lake and Topock Marsh, February 2006.

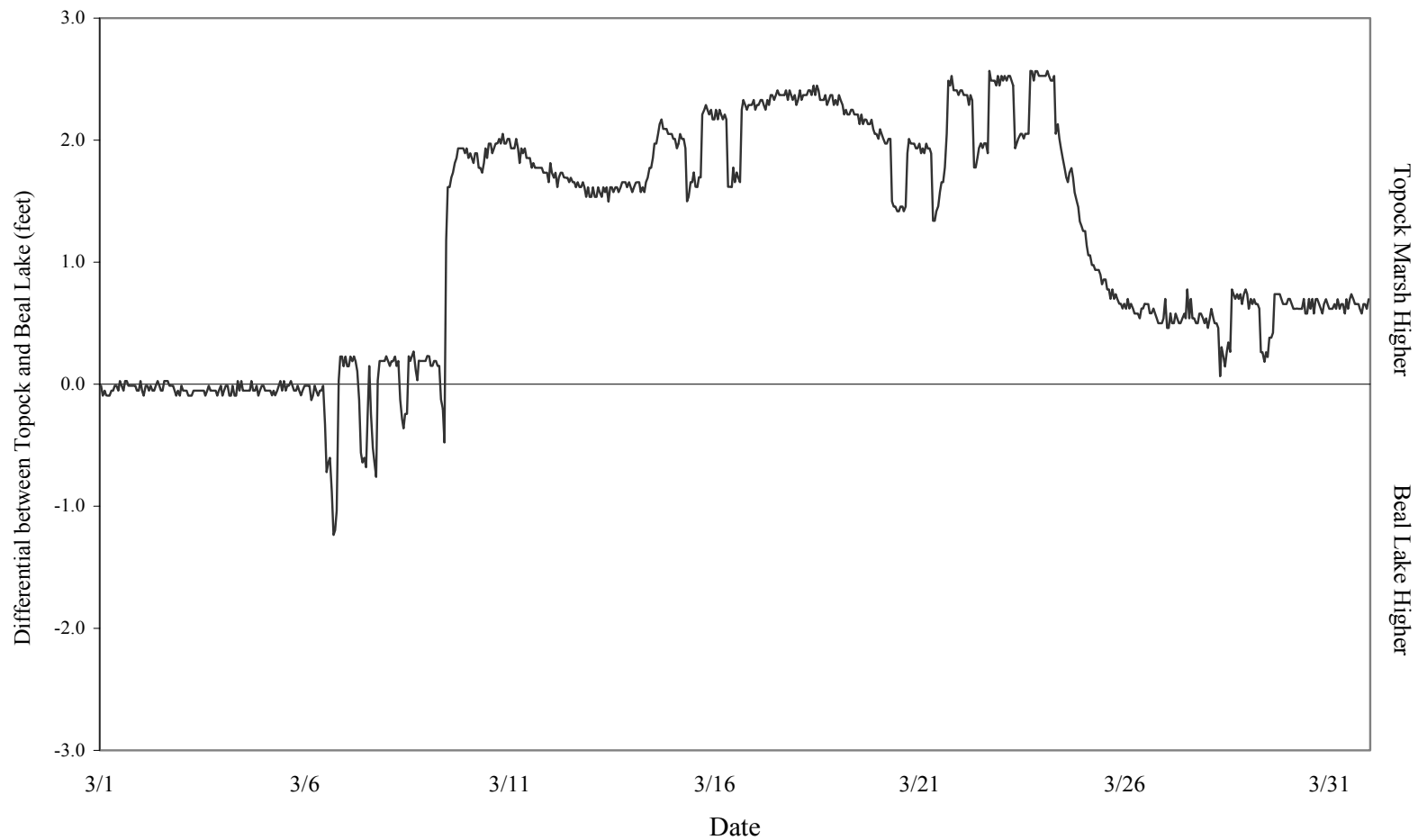

Appendix Figure C-3. Water level differential between Beal Lake and Topock Marsh, March 2006,

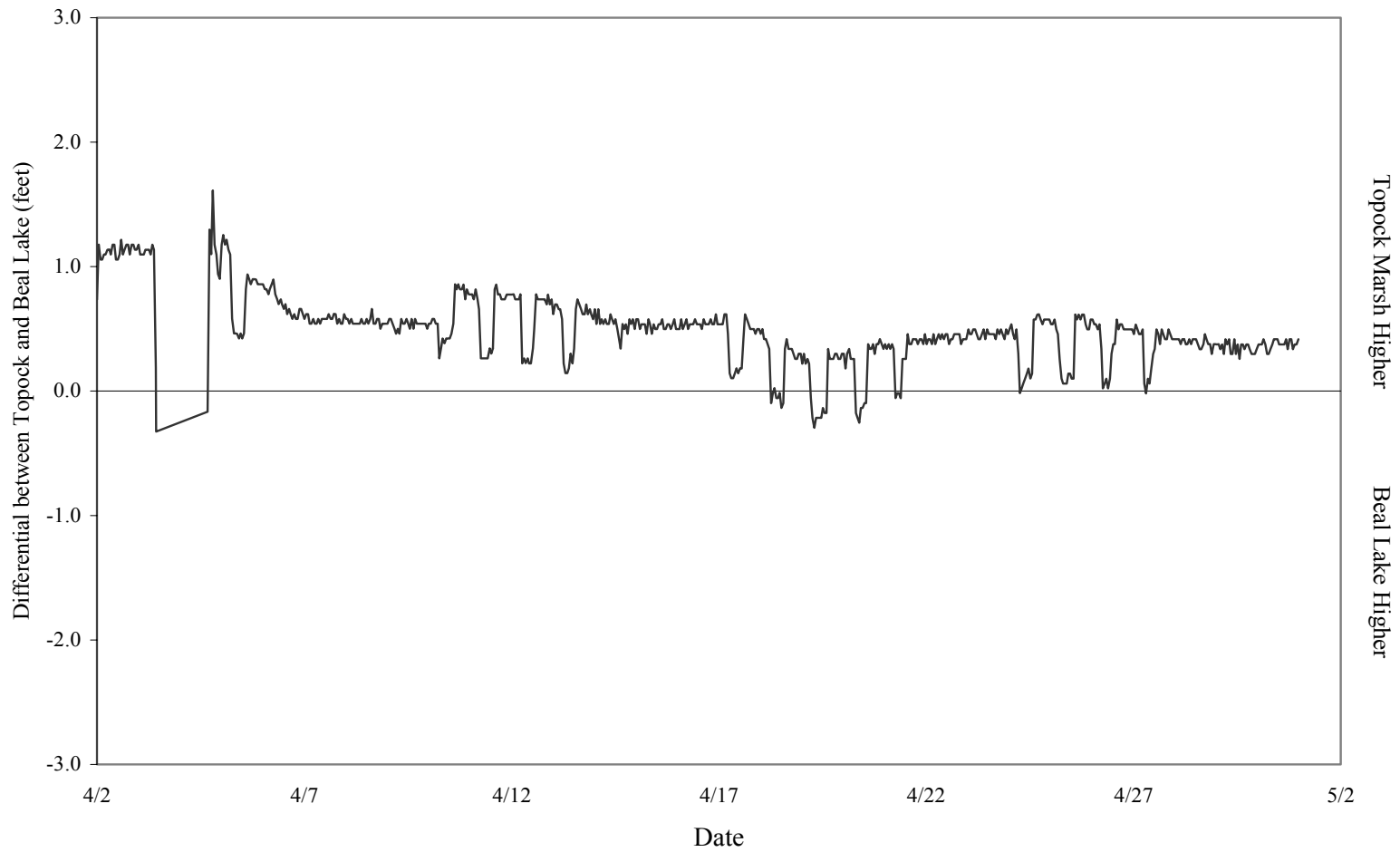

Appendix Figure C-4. Water level differential between Beal Lake and Topock Marsh, April 2006

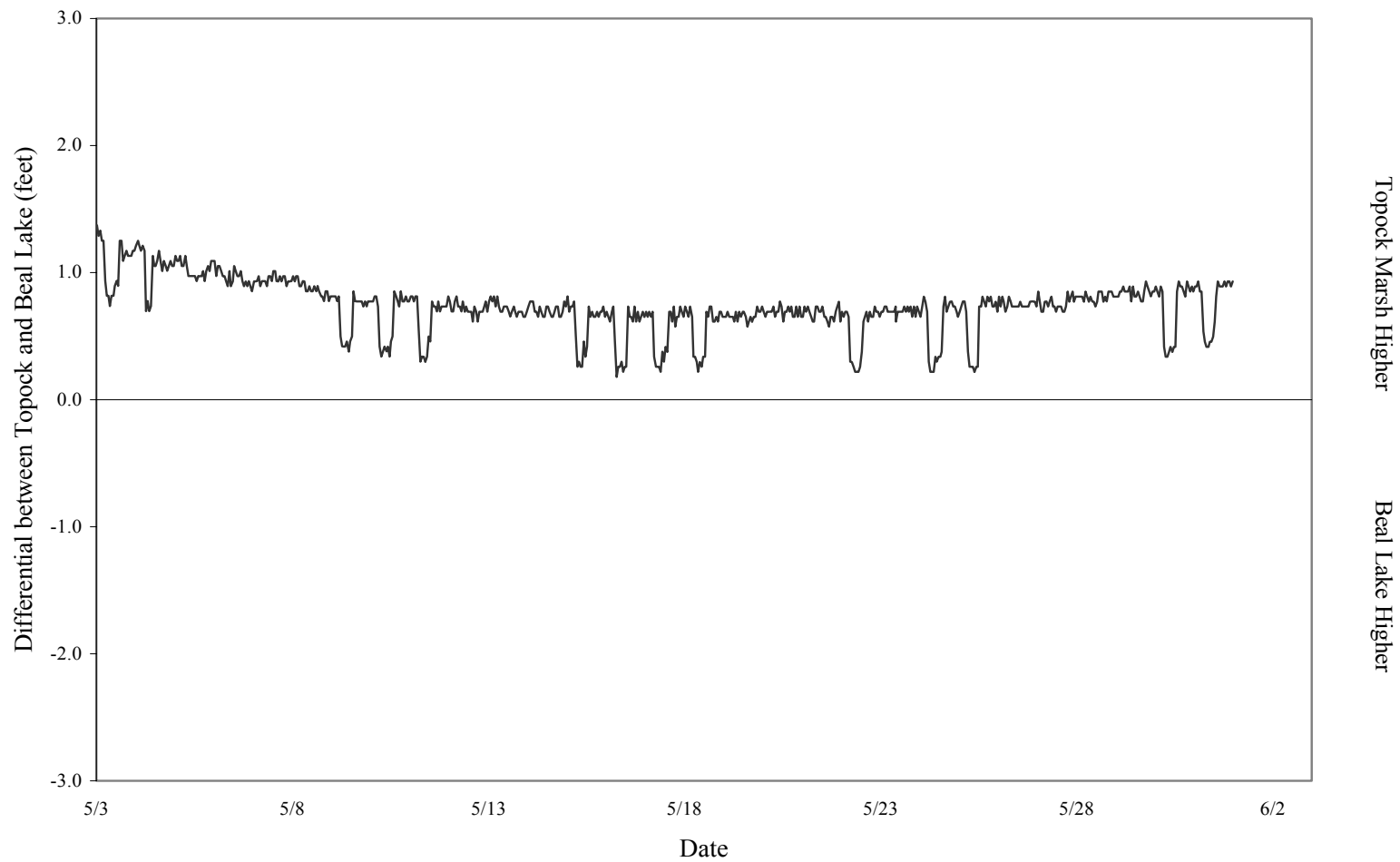

Appendix Figure C-5. Water level differential between Beal Lake and Topock Marsh, May 2006

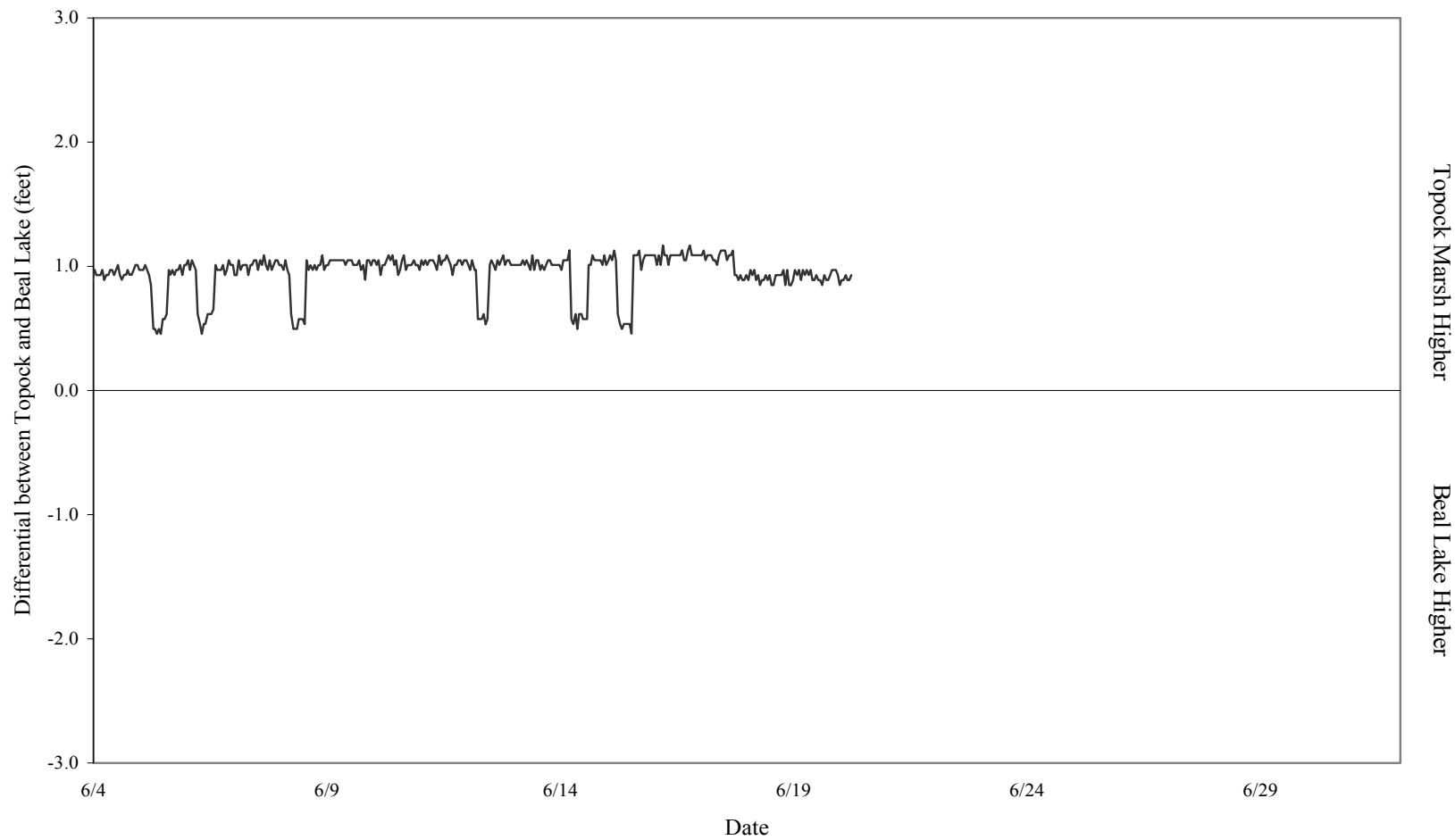

Appendix Figure C-6. Water level differential between Beal Lake and Topock Marsh, June 2006.

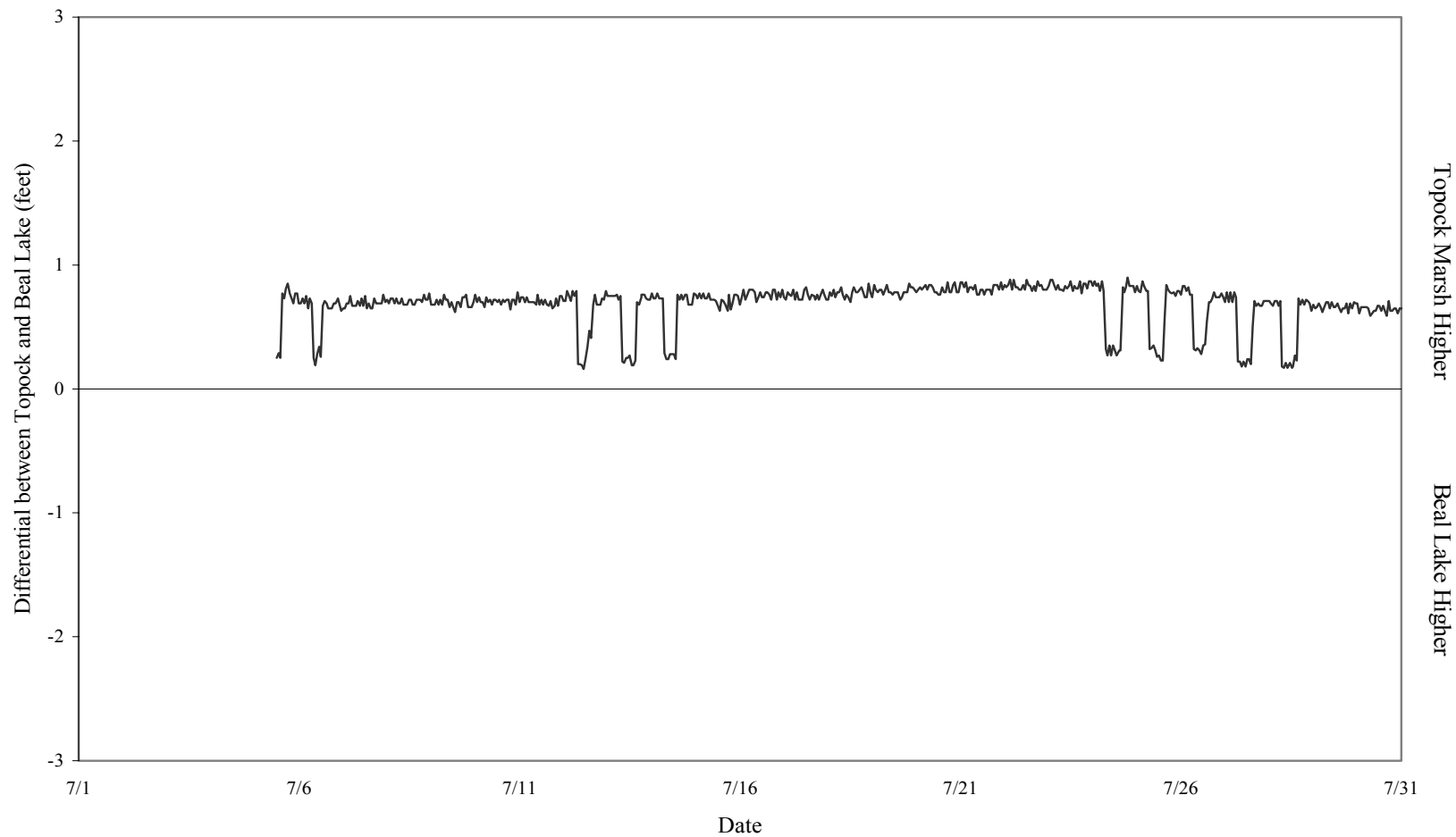

Appendix Figure C-7. Water level differential between Beal Lake and Topock Marsh, July 2006.

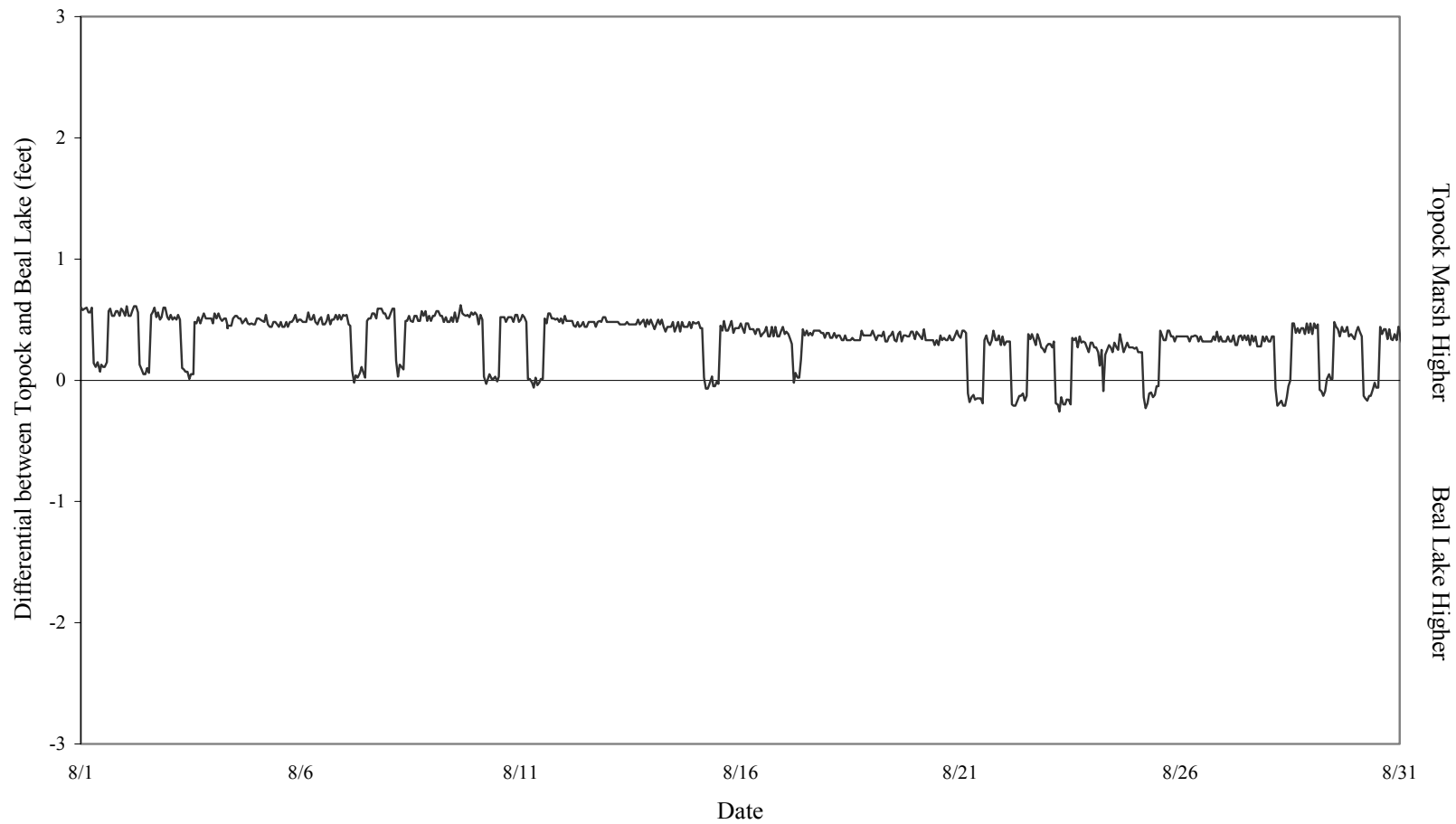

Appendix Figure C-8. Water level differential between Beal Lake and Topock Marsh, August 2006.

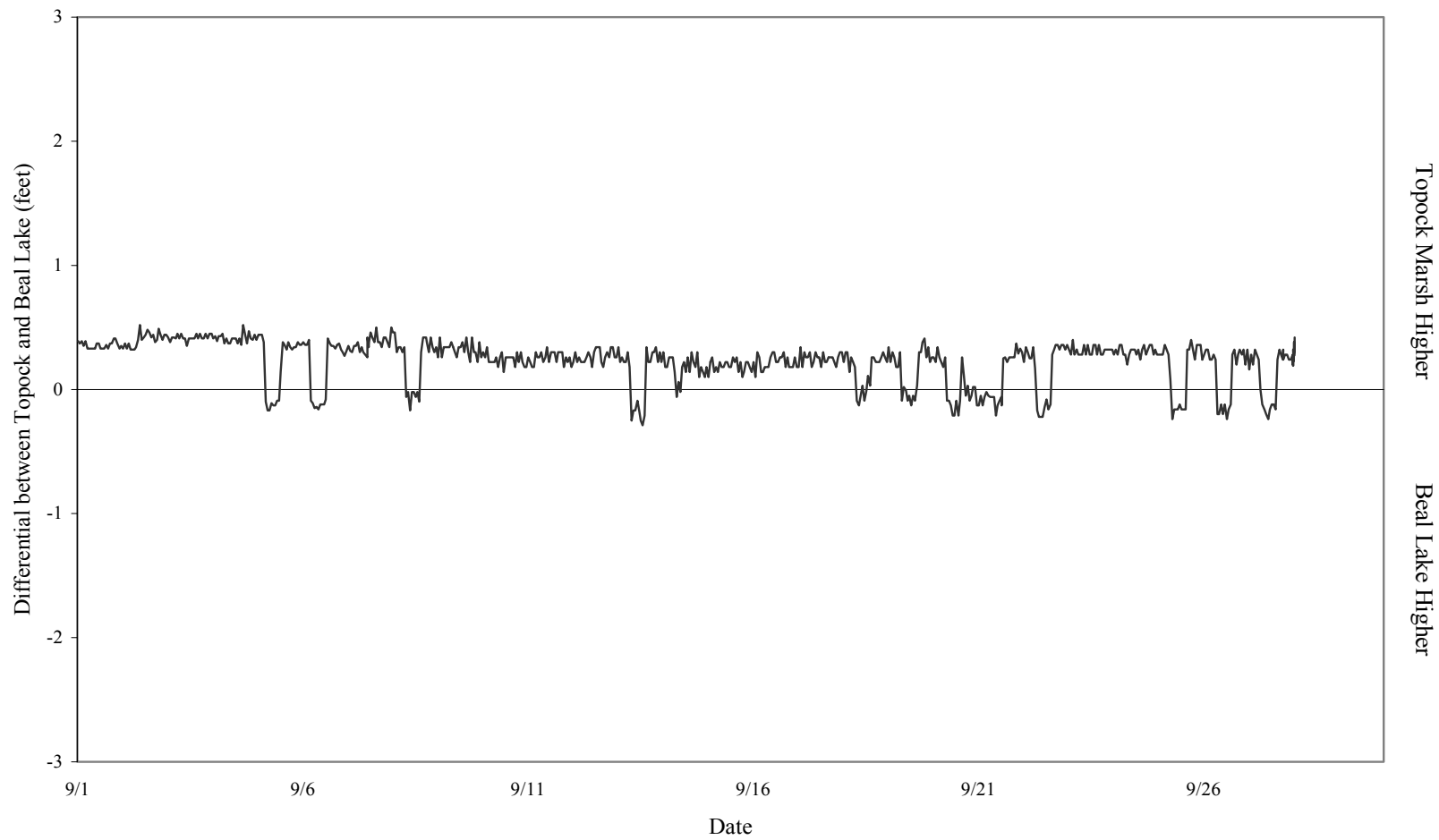

Appendix Figure C-9. Water level differential between Beal Lake and Topock Marsh, September 2006.

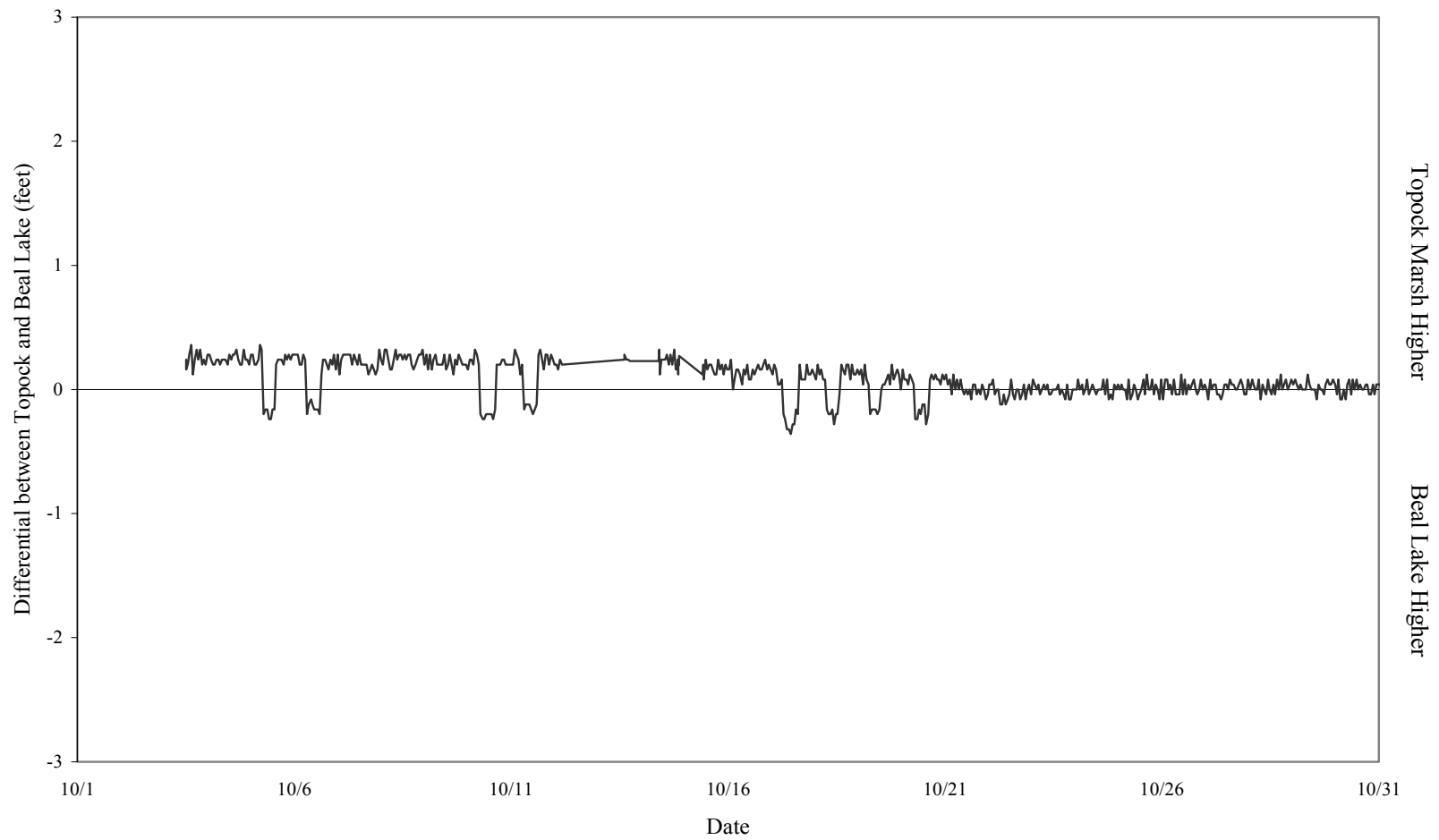

Appendix Figure C-10. Water level differential between Beal Lake and Topock Marsh, October 2006.

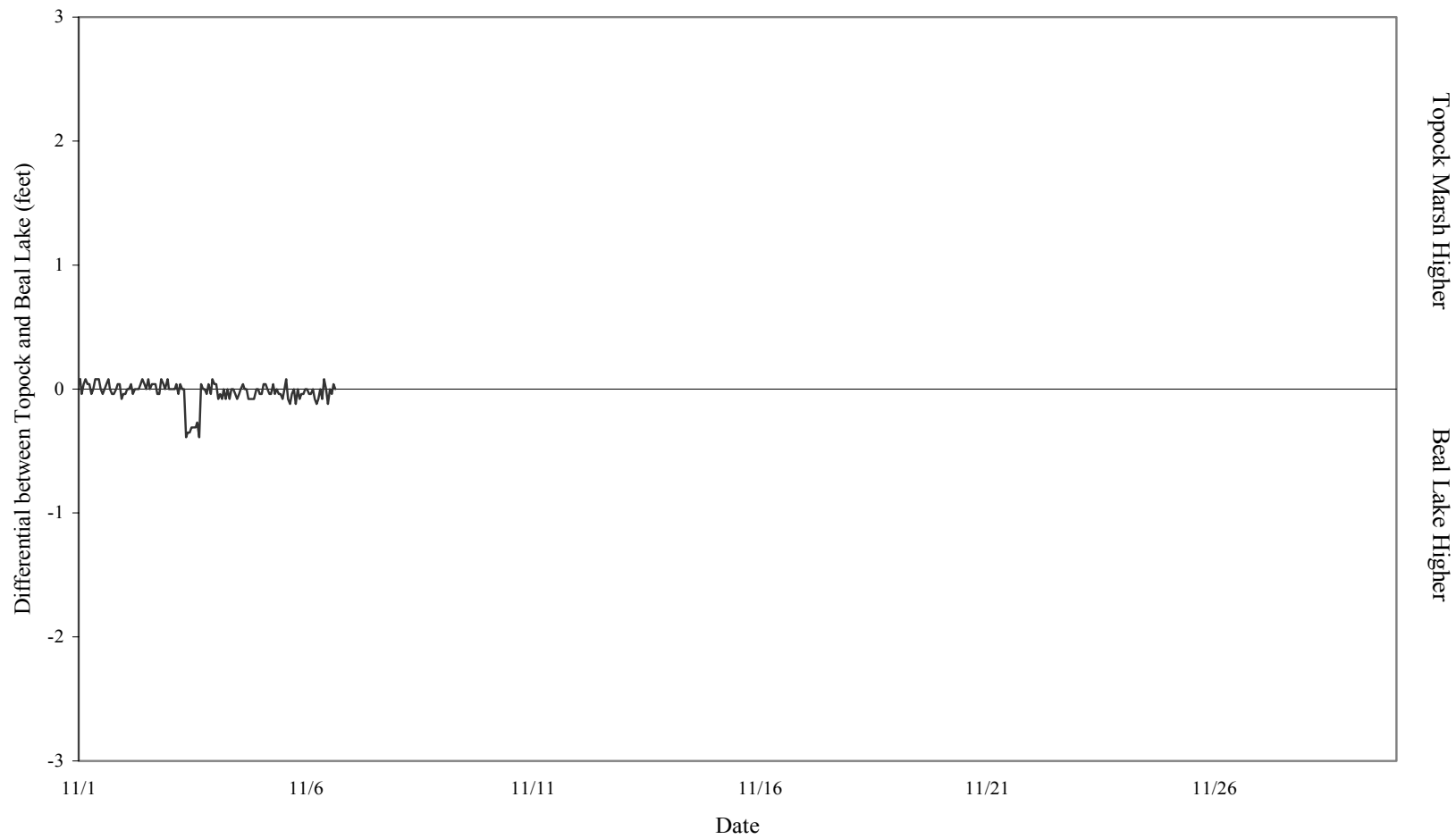

Appendix Figure C-11. Water level differential between Beal Lake and Topock Marsh, November 2006.