

# TABLE OF CONTENTS

	Page
E-5 Risk Analysis for Concrete Buttress Dams.....	E-5-1
E-5.1 Key Concepts .....	E-5-1
E-5.2 Finite Element Models .....	E-5-3
E-5.3 Struts .....	E-5-6
E-5.4 Slabs and Corbels.....	E-5-7
E-5.5 Arches or Domes.....	E-5-11
E-5.6 Buttresses .....	E-5-13
E-5.7 Displacement Criteria .....	E-5-16
E-5.8 Event Tree .....	E-5-16
E-5.9 Accounting for Uncertainty .....	E-5-18
E-5.10 Relevant Case Histories .....	E-5-18
E-5.10.1 Gleno Dam: 1923.....	E-5-18
E-5.10.2 Vega de Tera Dam: 1959.....	E-5-19
E-5.11 References.....	E-5-20

## Figures

Figure	Page
E-5-1 Examples of buttress dams.....	E-5-1
E-5-2 Zangar pressure coefficients for sloping surfaces (from Zangar [1952]).....	E-5-4
E-5-3 Example of strut socket within buttress.....	E-5-6
E-5-4 Time-history of forces in struts (compared to code capacity). .....	E-5-8
E-5-5 Example of strut removal exercise (due to seismically induced loads exceeding capacity). .....	E-5-9
E-5-6 Example of corbel-beam submodel. ....	E-5-10
E-5-7 Contour plot of maximum principal tensile stresses following strut removal – buttress 45 (time = 7.52 seconds) – Saratoga ground motions.....	E-5-13
E-5-8 Time history plot of maximum principal tensile stresses following strut removal – buttress 25.....	E-5-13
E-5-9 Moment capacities (lb-in) of a buttress by elevation.....	E-5-14
E-5-10 Buttress seismic moment time histories.....	E-5-15
E-5-11 Event tree for seismic buttress dam evaluation.....	E-5-17
E-5-12 Cross section of Vega de Tera Dam (adapted from International Commission on Large Dams 1974). .....	E-5-20



# E-5 RISK ANALYSIS FOR CONCRETE BUTTRESS DAMS

## E-5.1 Key Concepts

Buttress dams are concrete structures consisting of two basic features: an upstream water barrier and buttresses. The upstream water barrier can be a flat slab, large domes, cylindrical arches, or massive heads (figure E-5-1).

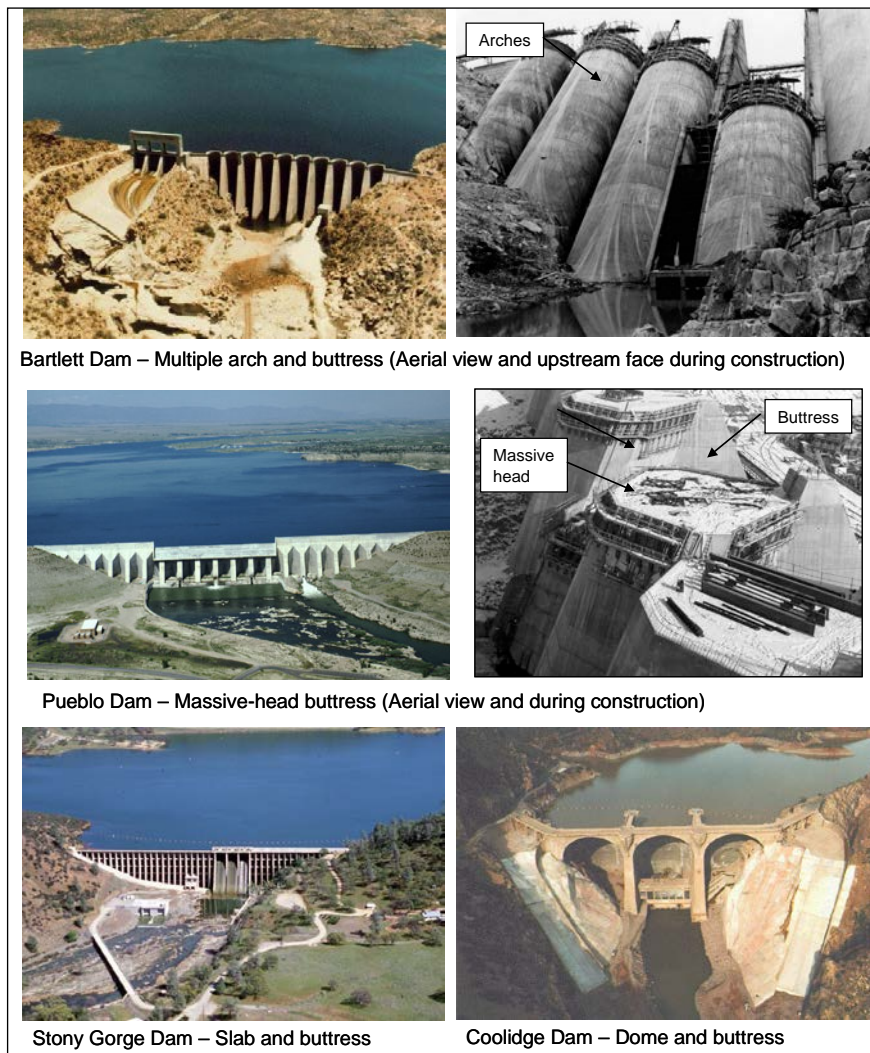

Figure E-5-1.—Examples of buttress dams.

## Chapter E-5 Risk Analysis for Concrete Buttress Dams

The upstream water barrier transfers the reservoir load into the buttresses that then transfer the load into the foundation through frictional and cohesive resistance like a gravity dam. They were typically built in the first half of the 20th Century instead of gravity dams to save on concrete material costs. Buttress dams can be thought of as hollowed-out gravity dams with a sloping upstream face. However the reduction in weight requires the sloping upstream face which allows the buttresses to efficiently carry static loads, because the weight of the water on the dam adds to the vertical force transmitted to the foundation and therefore the stability of the dam. Simply supported struts may be installed perpendicular to and between buttresses to provide lateral support. Struts may not be installed if the buttresses are more massive. Depending on the thickness of the concrete members, buttress dams may or may not have reinforcing steel. Given that most of the buttress dams were built in the early 1900s and the static loads are carried in compression, so reinforcement is minimal by current standards. Field verification may be useful to confirm location and volume of reinforcement prior to analysis efforts if as-built drawings are not available or are unclear.

Historically, the leading cause of concrete buttress dam failures (for those founded on rock) has been attributed to excessive deformations of the structural members related to improper design or deformable support (see case histories at the end of this section). However, sliding on planes of weakness within the foundation rock or planes of weakness caused by improper construction is also a significant contributor, and may have been the ultimate failure mechanism even for those dams where failure was initiated by excessive deformation. Sliding stability of the buttresses is therefore an important consideration. Referred to “chapter E-5, Risk Analysis for Concrete Gravity Dams,” “chapter E-4, Risk Analysis for Concrete Arch Dams,” and chapter E-3, Risk Analysis for Concrete Gravity Structures” for additional discussion of sliding on weak lift joints and planes in the foundation.

Buttress dams are very efficient in carrying static loads. In general, the upstream slab is constructed at a 45 degree angle. As a result, loads associated with the reservoir can be considered as two directional components. Half of the load contributes to the horizontal driving force component, while half of the load contributes to the vertical normal force component aiding in the stability of the dam. On the other hand, buttress dams are not designed to carry significant load in the cross-canyon direction. Strong earthquake ground motions in the cross-canyon direction can load the buttresses in a manner that was not intended by the design, perhaps leading to distress and failure. The rest of this section concentrates on evaluating seismic failure mechanisms due to cross canyon loading.

Buttress dams are typically designed as reinforced concrete structures (although some elements may be mass concrete depending on the thickness) and should be accordingly analyzed. It is important to obtain reinforcement as-built drawings to determine details such as bar sizes and spacing, stirrups, and embedment lengths.

## Chapter E-5 Risk Analysis for Concrete Buttress Dams

It must be recognized that older structures will not be detailed exactly in accordance with current American Concrete Institute (ACI) code. In particular, they are likely to lack the “integrity reinforcement” required by the current code. Therefore the structure should not be condemned for lack of compliance with detailing requirements unless such noncompliance really affects the strength of the structure. It is also important to remember that the code is the basis for new designs that are expected to perform well without much in the way of distress. However, in a risk analysis, the goal is to make an estimate as to what the actual failure probability is likely to be. Therefore, fragility estimates need to take into consideration the likely factors of safety built into the code.

It should be noted that the thickness and sizes of the slabs, corbels, and buttresses can be larger than typically dealt with in the ACI code. The cylindrical arches at a 300-foot-high multiple arch dam vary from 7-feet thick at the base to 2-feet thick at the crest. The buttresses at a 250-foot-high massive head buttress dam are 18-feet thick. As such, the following aspects should be considered: 1) the tensile strength of the concrete can play a significant role in the stability of the structure (The ACI code considers that only the reinforcing steel carries tensile loads. In reality the concrete in massive concrete structures can carry significant tensile loads and the reinforcing steel will not even be mobilized if the concrete does not crack), 2) for large members, deep beam techniques and strut-and-tie methods should be used, and 3) shear friction along slide surfaces should include the weight (or compressive loads) of the structure and friction between the concrete surfaces and not just the shear resistance developed by the reinforcing steel. Exposure and corrosion of reinforcing steel can reduce the capacity of the reinforced concrete elements. This typically only occurs in localized areas, and examination of the structure may help define whether this occurs in a critical area or over a large enough area to be of concern.

### E-5.2 Finite Element Models

Finite element models are important in evaluating the likelihood of failure of the various structural elements in a concrete buttress dam due to seismic loading. Because considerable “racking” or accumulation of load across the structure as a result of cross-canyon displacements can occur during seismic loading, it is typically necessary to model all the buttresses in the dam using a three-dimensional model in order to properly capture the cross-canyon loads, and systematic interaction of all components. Shell elements can be used to model the structural members in thin structures. Solid elements may be better suited for thicker buttresses. Special attention must be paid in modeling the connections between the various structural members. Simply supported struts can be modeled as compression-only springs, or beam elements. Coupling equations or special connections can be used for simply-supported slab elements, depending on the program being used. Careful attention should be given to the interaction and load transfer between members, as each will be loaded and respond differently

## Chapter E-5 Risk Analysis for Concrete Buttress Dams

depending on the direction of the earthquake motion. While methods of analysis could vary, considerations for the evaluation should reference recommendations discussed in this section.

Hydrodynamic forces acting on upstream sloping surfaces are typically accounted for using Zangar's approach. As the slope of the face becomes flatter, the tendency is for the water to ride up along it rather than push directly against it as a result of horizontal shaking (which moves the dam into the reservoir), resulting in a reduction in pressures. Figure E-5-2 or "Figures 5 and 6" from Zangar (1952) illustrate the resulting pressure distribution for various slope faces.

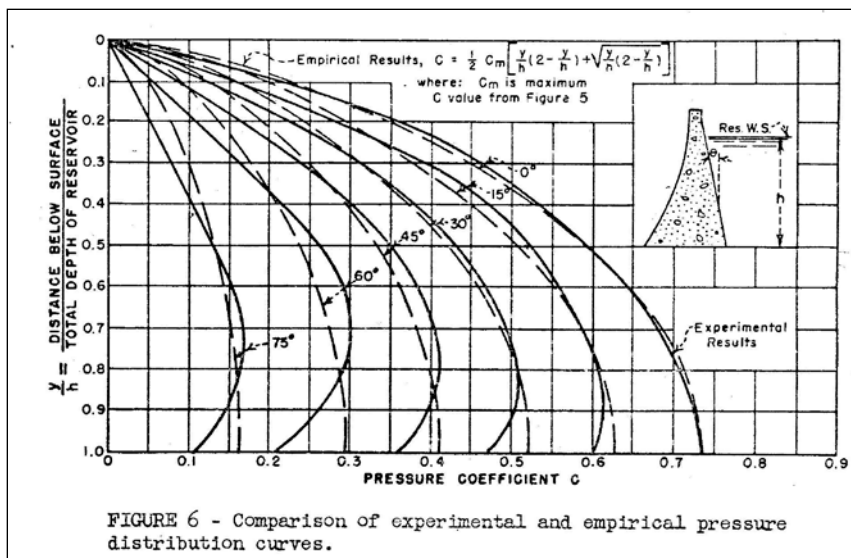

FIGURE 6 - Comparison of experimental and empirical pressure distribution curves.

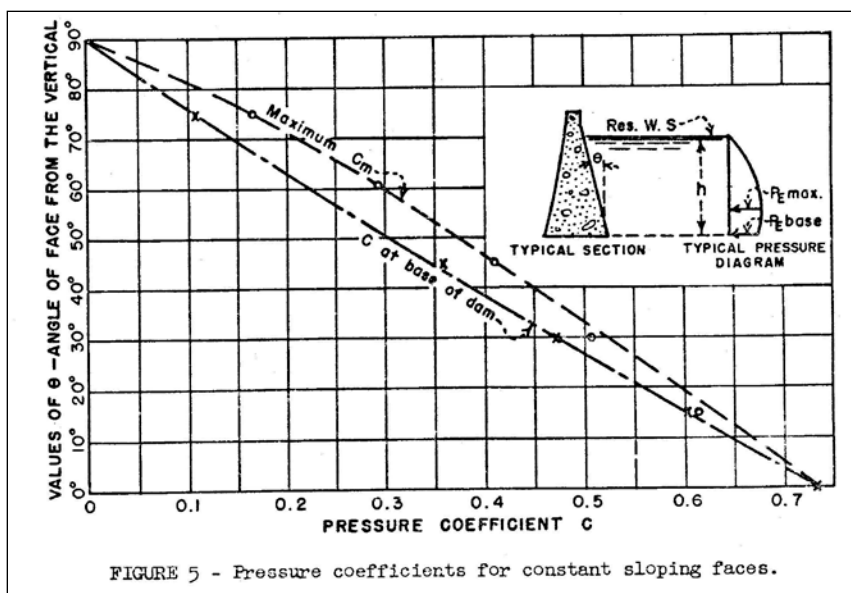

FIGURE 5 - Pressure coefficients for constant sloping faces.

Figure E-5-2.—Zangar pressure coefficients for sloping surfaces (from Zangar [1952]).

## Chapter E-5 Risk Analysis for Concrete Buttress Dams

The dimension of the hydrodynamic mass acting with the dam at any elevation is equal to  $C \cdot h$ , where  $C$  is the coefficient from “Figure 6,” and  $h$  is the total reservoir depth at the section where the pressure is calculated. The water mass acting on a slab (normal to the face) due to horizontal ground acceleration as described above can be converted to a pressure (also normal to the face) by multiplying by  $\alpha H \gamma_w$ , where  $\alpha H$  is the horizontal earthquake acceleration as a fraction of gravity, and  $\gamma_w$  is the unit weight of water.

The vertical motion acts on the total mass of water directly above the dam face; the water cannot ride up the dam face as a result of the vertical motions (which push the dam upward into the reservoir). Therefore, the entire mass of water directly over the dam face is typically assumed to move with the vertical motions. This however is not the case in for the horizontal direction. This creates a complication as to what mass to attach to the upstream face. If application reservoir loads uses a method involving added mass, an analysis program which can apply the vertical and horizontal masses correctly should be used. Note that some programs are limited in the ability to apply the added mass normal to the dam face.

Although reservoir loads have been applied using converted hydrodynamic pressure to mass along the face of the dam in the past, the preferred method of analysis is to model the reservoir with fluid elements. In such cases, significant model verification is essential to ensure proper behavior of the reservoir and proper interaction of the reservoir with the structural elements, which can be checked using Zangar’s method. Overall, however the dynamic behavior of the water is better represented through fluid elements.

The foundation stiffness can have a large effect on the rotations at the base of the buttresses and the dynamic response of the dam. For this reason, it is important to model the foundation underneath the buttresses in the finite element model. If it is impractical to model the foundation with solid elements, a series of springs and dampers can be used at the base of the dam to simulate the dam-foundation interaction.

Damping is also an important consideration, as increased damping values will reduce the forces, moments, and stresses. There may be a reasonable level of damping at which the model will perform well, and another slightly lower level at which it will perform poorly. For models where only small elastic displacements are being calculated, damping of about 5 percent of critical at the fundamental mode is usually appropriate. Slightly higher values can be considered if large deformations indicate non-linear behavior is likely, but not more than 7 to 10 percent. However, the use of high damping is justified because the structure is likely behaving non-linearly (perhaps involving some concrete cracking and sliding at simply supported contacts). Therefore, it may not be appropriate to then use the lower stresses in the structure calculated with high damping values to justify a low probability for concrete cracking.

### E-5.3 Struts

Struts, where present, provide some lateral support to the buttresses, but this support may not be sufficient to carry loads from lateral earthquake motions. Typically, an iterative process is used to evaluate the strut loads in comparison to the capacity of the struts for ground motions at various return periods, using a finite element model. After an initial run, the compressive forces in the strut elements are evaluated relative to both the compressive strength capacity of the struts and the potential for buckling. The potential for buckling of various struts can be checked using the Euler formula:

$$PCR = \pi^2 EI / (kL)^2 \quad \text{Equation E-5-1}$$

Where PCR is the critical buckling load, E is the elastic modulus of the concrete, k is the slenderness ratio (1.0 for pinned ends and 0.5 for fixed ends), I is the moment of inertia about the weak axis, and L is the length of the compression member. Typically, the struts are cast into sockets in the buttresses. The details should be examined closely to determine whether the connection is better modeled by a fixed or pinned connection relative to rotation, as some sockets can be shallow as shown on figure E-5-3.

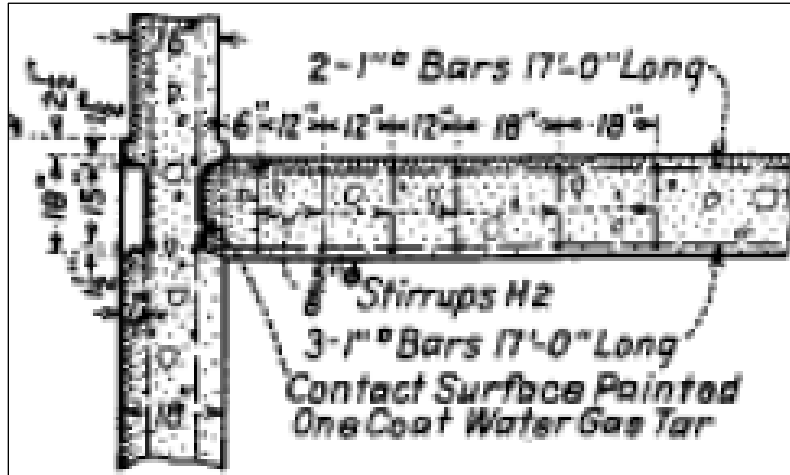

Figure E-5-3.—Example of strut socket within buttress.

Additional consideration should be given to the design reinforcement for the strut, and whether the reinforcement layout meets adequate confinement criteria. In the case the member is under reinforced, the capacity of the strut should be examined as a compression member and not an axial/bending member.



## Chapter E-5 Risk Analysis for Concrete Buttress Dams

Typically the buckling or crushing capacity of the struts is the controlling force on the struts. At a 140-foot-high slab and buttress dam the buckling capacity of the 18-inch by 18-inch by 18-foot long struts is the following:

$$P_{CR} = \pi^2 EI / (kL)^2 = \frac{[(3.142)(3,500,000 \text{ lb/in}^2)[(1/12)(18 \text{ inches})^4]}{6.5 \text{ million lb}} / [(1.0)(18\text{-feet})(12(\text{in/ft}))^2] = \text{Equation E-5-2}$$

The ultimate (crushing) capacity of concrete with adequate reinforcement confinement is the following ( $f'_c = 3770 \text{ lb/in}^2$  based on  $E = 3,500,000 \text{ lb/in}^2$ ):

$$P_u = (A)(f'_c) (18\text{-inch})(18\text{-inch}) * (3,770 \text{ lb/in}^2) = 1.2 \text{ million lb} \quad \text{Equation E-5-3}$$

(no load factors should be applied)

Additional consideration should be given to the existing reinforcement in the concrete, if known, and the appropriate contribution to the strength capacity. While the intent of the structural analysis is not to compare the structural design to the current ACI code requirements, the requirements can be used to support additional calculations to verify structural stability given current loads. For instance, if the strut does not contain adequate reinforcement confinement, consideration should be given to evaluate the section as plain concrete under axial compressive load. Guidance on plain concrete capacity can be referenced in ACI 318-14, chapter 14, section 14.5.3.1 (ACI 2014).

$$P_n = 0.60 * f'_c * \left[1 - \left(\frac{l_c}{32h}\right)^2\right] A_1 \quad \text{Equation E-5-4}$$

If the strength of a strut is thought to be exceeded, that strut is removed from the model, and the analysis run again. This is repeated until no more struts fail, or no more struts exist in the model. The stability of the slabs and corbels (or arches/domes) and buttresses are then evaluated as described below.

Figure E-5-4 shows time history forces which indicate the capacity of the struts has been exceeded, and figure E-5-5 shows the sequence of removing struts from the model.

### E-5.4 Slabs and Corbels

A slab-type water barrier consists of a simply-supported reinforced concrete slab supported by a reinforced concrete corbel that runs along the upstream edge of the buttresses and facilitates load transfer into the buttresses. The slab and corbel carry load by shear, compression bearing, and moment. Loads include self-weight, hydrostatic pressures, seismic inertia loads, and hydrodynamic pressures produced by earthquake loading. Additional loads which should be

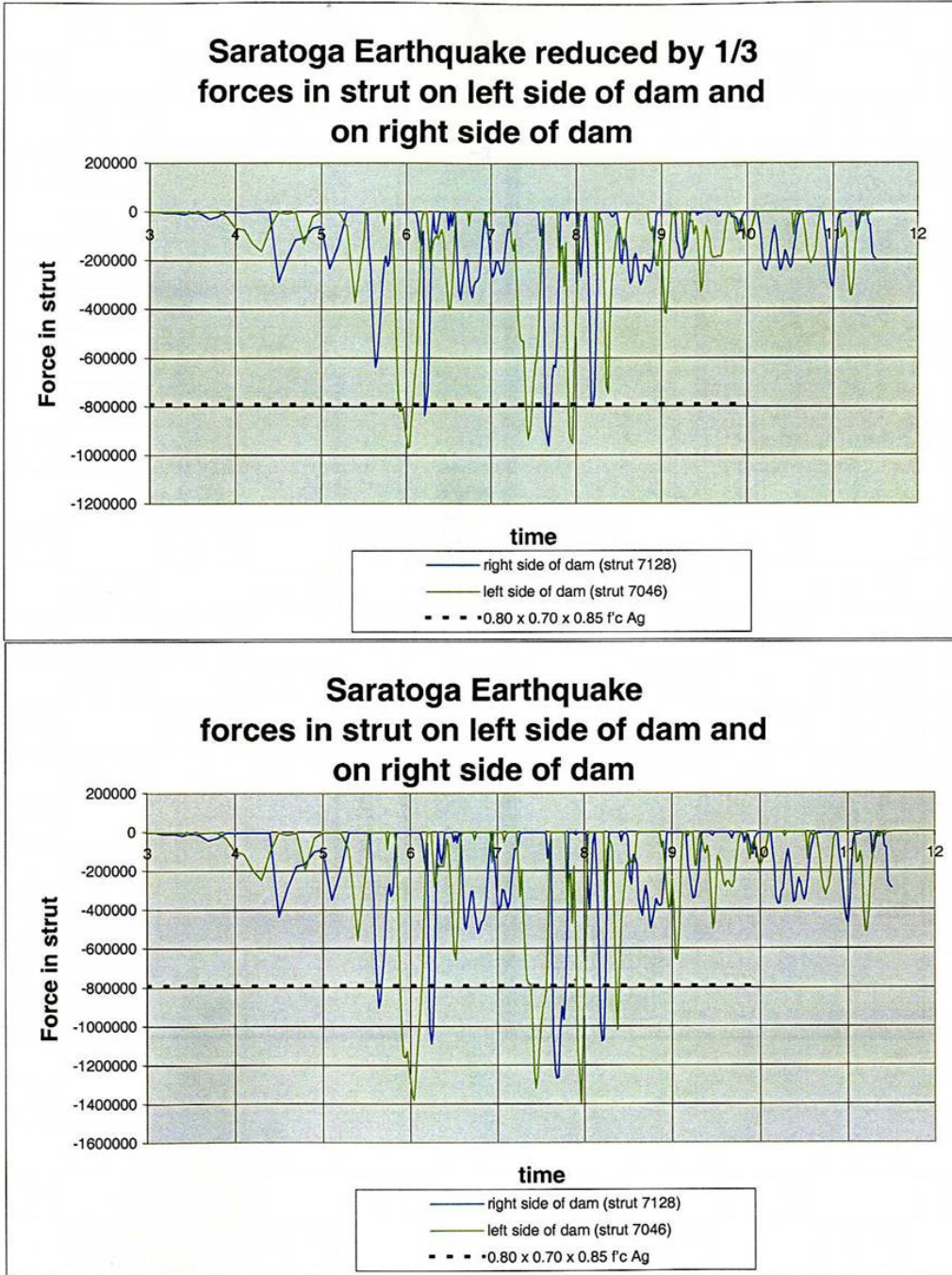
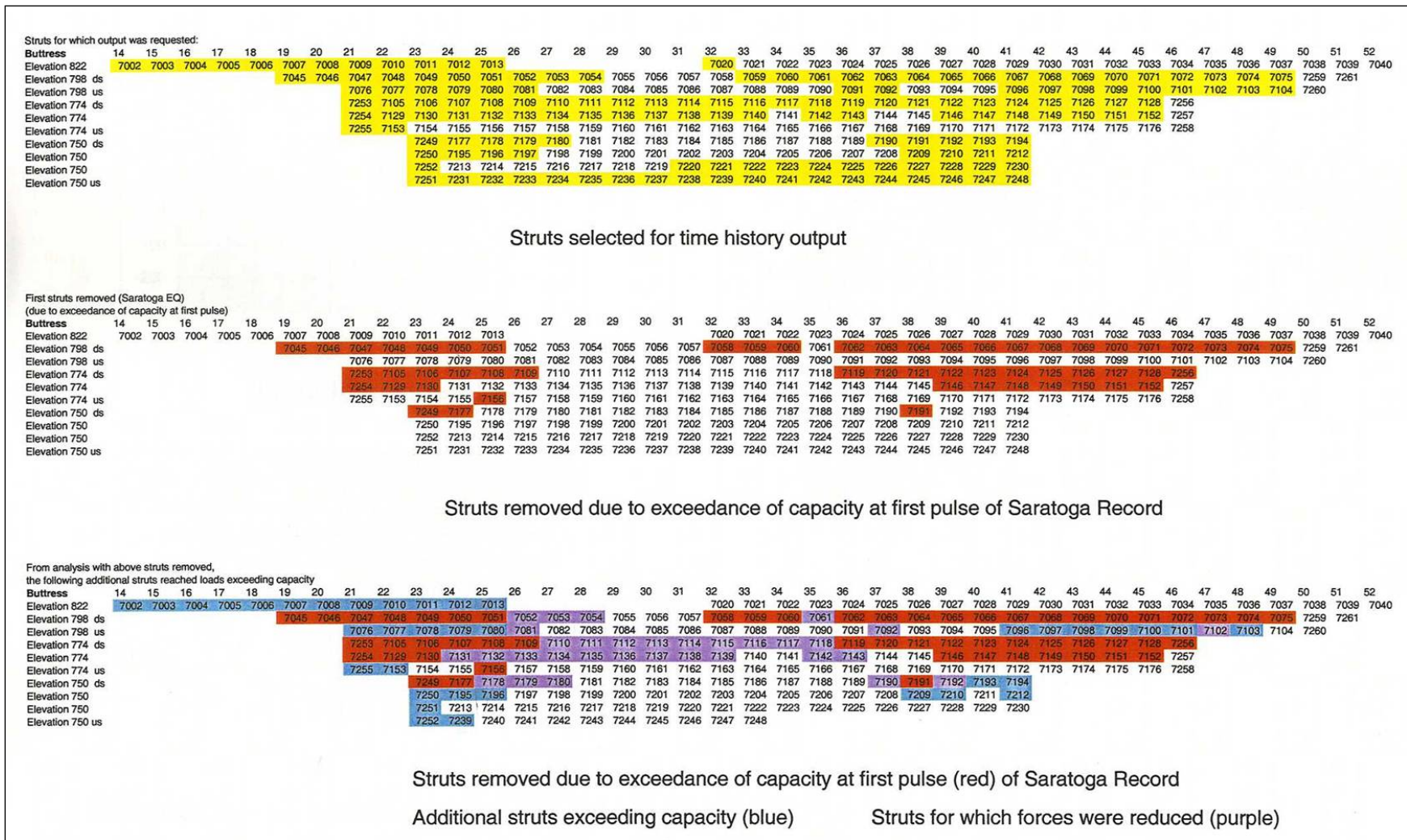

Figure E-5-4.—Time-history of forces in struts (compared to code capacity).

## Chapter E-5 Risk Analysis for Concrete Buttress Dams



**Figure E-5-5.—Example of strut removal exercise (due to seismically induced loads exceeding capacity).**

## Chapter E-5 Risk Analysis for Concrete Buttress Dams

considered based on the scenario are silt (current and perhaps considering long-term accumulation, as appropriate). Flood and earthquake loads are typically not combined.

For static loads, simple hand or spreadsheet calculations are sufficient to determine the capacity of the members. For dynamic loads, full three-dimensional finite element models are required because of the complexity of the structures. The demand/capacity ratios are calculated, which in turn can be used to estimate the likelihood of failure, as described in “chapter E-2, Reinforced Concrete Failure Mechanisms.”

If straight simply supported slabs form the upstream face of the dam, there is no hydrodynamic loading in the cross-canyon direction. Therefore, it is appropriate to evaluate the slabs for moment and shear capacity due to upstream-downstream and vertical motions only. Applying the static and hydrodynamic pressure normal to the slab face in a pseudo-static sense can be used to check the moment and shear capacity of the slab at various elevations. The shear capacity of the slabs is typically checked at a distance “d”, equal to the slab thickness, from the support. The shear capacity of the corbels upon which the slabs rest must also be evaluated at various elevations. To evaluate the shear capacity of the slab considering the interaction with the corbel, as well as the existing reinforcement, an additional, reduced, sub model may be considered utilizing a 1-foot section along the height of the dam as shown on figure E-5-6. The sub model would incorporate the corbel and upstream slab, cut along the slab centerline, and will include the slab reinforcement.

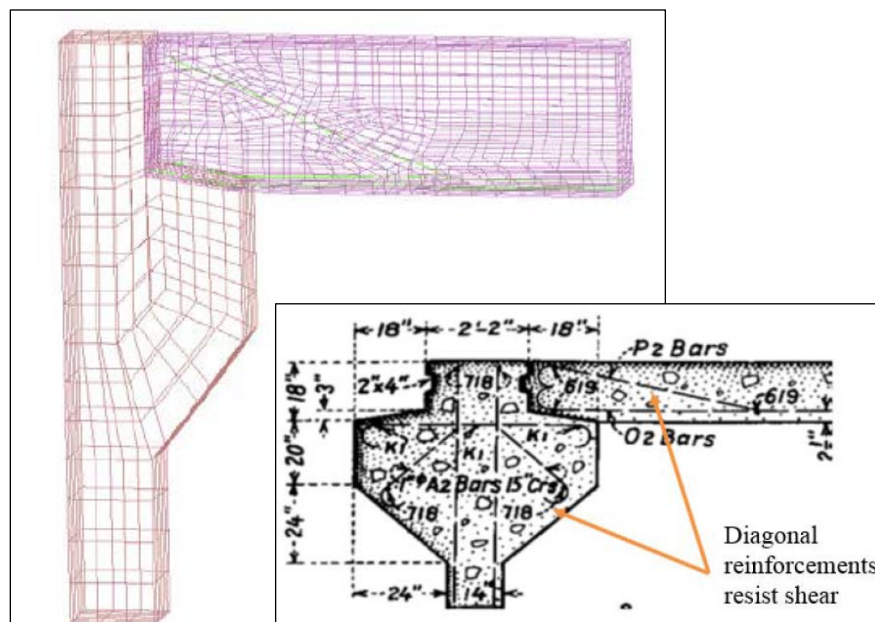

Figure E-5-6.—Example of corbel-beam submodel.

## Chapter E-5 Risk Analysis for Concrete Buttress Dams

Load applied to upstream slab would be adjusted until either the flexural or shear reinforcement reached yield strength, establishing the capacity of slab. This evaluation assumes that the corbel design, including reinforcement has been checked and had adequate capacity. Results from the sub model can be compared with demand from the full, simply supported model to establish the overall demand-to-capacity of the slab considering both moment and shear.

Again, the demand/capacity ratio is estimated to aid in estimating the likelihood of failure, as described in “chapter E-2, Reinforced Concrete Failure Mechanisms”.

The final check for the slabs is to examine how likely it is for the slabs to handle the cross-canyon compression loads due to cross-canyon displacements without failing in compression or buckling. For this check, the results of the finite element study must be evaluated. The stresses and moments in the slab elements must be checked. The compressive strength and moment capacity in the longitudinal and transverse directions are compared to the moments and forces induced in the slab at various elevations, and the demand/capacity ratios are used to estimate the likelihood of failure using the information in “chapter E-2, Reinforced Concrete Failure Mechanisms.”

Failure of a slab suggests that uncontrolled release of the reservoir is likely. The loads needed to cause buckling are typically much higher than those required for crushing such that crushing typically controls the failure likelihood. It should be noted that localized areas where demand exceeds capacity may not indicate total failure of the component. Large areas must be affected for failure to be indicated.

### E-5.5 Arches or Domes

Arch, dome, or massive-head upstream water barriers typically are an integral part of the buttress with continuous reinforcement going from the barrier into the buttress. There may be a construction joint along the interface between the buttress and barrier, and lap splices may be installed in the reinforcement at that location. There may be no reinforcement between the massive heads and the buttresses of a massive head dam, but the massive head concrete is integral with or bonded to the buttress concrete along a construction joint. Moments are produced along these types of connections that can crack the concrete and load the reinforcing steel. Loads include self-weight, hydrostatic pressures, seismic inertia loads, and hydrodynamic pressures produced by earthquake loading. Additional loads which should be considered based on the scenario are silt (current and perhaps considering long-term accumulation, as appropriate. Flood and earthquake loads are typically not combined.

## Chapter E-5 Risk Analysis for Concrete Buttress Dams

For static loads, simple hand or spreadsheet calculations are sufficient to determine the demand and capacity of the members. For dynamic loads, full three-dimensional finite element models are required because of the complexity of the structures. The demand/capacity ratios are calculated, which in turn can be used to estimate the likelihood of failure, as described in “chapter E-2, Reinforced Concrete Failure Mechanisms,”

Cross-canyon hydrodynamic forces act on cylindrical arches, domes, and massive-head buttresses (in contrast to flat slabs upon which these forces do not act). The best way to account for the hydrodynamic interaction in these cases is to explicitly model the water in the 3-dimension finite element models, if time and budget allows. It was shown in a multiple arch model (without struts between buttresses) that (1) the outer two arches took proportionally more hydrodynamic load than the interior arches (the outer two arches did not have the “shielding” effect from adjacent arches that the interior arches had) and (2) explicitly modeling the water produced much lower hydrodynamic pressures in the cross-canyon direction than Westergaard’s or Zangar predictions. Therefore, the added mass approach can be considered conservative if it is used in the calculations.

The results of the finite element studies are typically used to evaluate the stability of the water barrier and its ability to contribute to lateral support of the buttresses. Stresses on the upstream and downstream faces in the barriers at locations of maximum compressive and tensile stresses are first compared to the concrete strengths (see “chapter E-1, Concrete Property Considerations” for a discussion of concrete tensile strength). If cracking appears to be likely and the extent of cracking is over a large area, the stresses are converted to an axial load and bending moment based on the stress distribution using the equation  $\phi = P/A \pm Mc/I$  (see “chapter E-2, Reinforced Concrete Failure Mechanisms” for an example of how this is done). Axial load (P) vs. moment (M) interaction diagrams are then used to compare the induced loading to the capacity of the reinforcement. If the arches are shown to crack over a large area and the displacements are relatively large compared to the size of the arches, the capacity (as simulated by the modulus in the finite element model) of the arch elements can be reduced to simulate the decrease in lateral support, and the analyses are re-run to evaluate the buttresses. Arches and domes carry load in a very efficient manner with most of the load carried in compression. For the arches or domes to fail and release the reservoir, there must be enough cracking to cause the arch to lose integrity or enough deformation to lose arching action (disruption of the load path). However, the likelihood of failure is currently estimated in a similar manner to other reinforced concrete members using the demand/capacity ratios as described in “chapter E-2, Reinforced Concrete Failure Mechanisms.”

## E-5.6 Buttresses

The stability of the buttresses is a function of the lateral support provided by the upstream water barrier, the lateral support provide by any struts (that survive seismic loading), the thickness and height of the buttress, the support condition between the buttress and foundation, the reinforcing steel and the magnitude and frequency content of the ground motions.

After the potential for loss of lateral support has been assessed, and finite element models analyzed with the appropriate loss of support, the buttresses are analyzed. Initially, the likelihood of concrete cracking is assessed by comparing maximum principal (tensile) stresses to the concrete strength, as shown on figures E-5-7 and E-5-8.

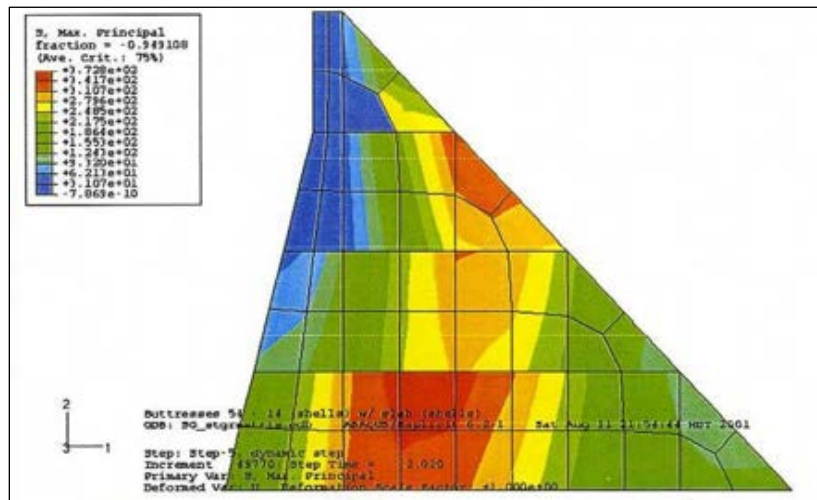

Figure E-5-7.—Contour plot of maximum principal tensile stresses following strut removal – buttress 45 (time = 7.52 seconds) – saratoga ground motions.

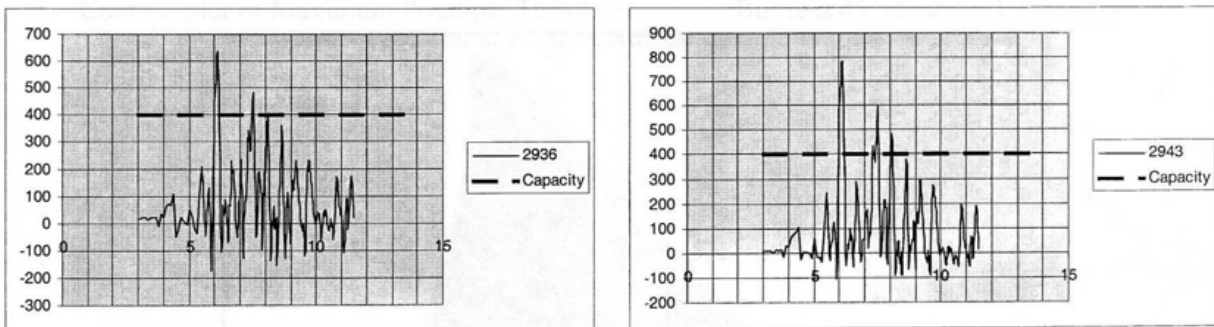

Figure E-5-8.—Time history plot of maximum principal tensile stresses following strut removal – buttress 25.

## Chapter E-5 Risk Analysis for Concrete Buttress Dams

If cracking is shown to be likely, the moments in the buttresses are compared to the moment capacity in both the horizontal and vertical directions to get a sense of how likely it is for the buttresses to fail under seismic loading, as shown on figures E-5-9 and E-5-10. The shear stress must also be checked (i.e. compare the induced shear stresses to the shear capacity), but it is unlikely to control the outcome of the evaluation (Sozen 1993). The demand/capacity ratios are used to estimate the likelihood of failure, as described in “chapter E-2, Reinforced Concrete Failure Mechanisms.” Again, localized areas where the demand exceeds the capacity does not necessarily mean the buttress will fail.

Elevations	Thickness	d	Vertical Mv Allowable	Horizonga Mh Allowable
834 - 846	18	16	$1.3 \times 10^5$	$0.7 \times 10^5$
822 - 834	20	18	$1.4 \times 10^5$	$0.8 \times 10^5$
810 - 822	22	20	$1.6 \times 10^5$	$0.9 \times 10^5$
798 - 810	24	22	$1.7 \times 10^5$	$3.7 \times 10^5$
786 - 798	26	24	$1.9 \times 10^5$	$4.1 \times 10^5$
774 - 786	28	26	$2.1 \times 10^5$	$1.2 \times 10^5$
762 - 774	32	30	$2.4 \times 10^5$	$1.4 \times 10^5$
750 - 762	36	34	$2.7 \times 10^5$	$1.6 \times 10^5$
738 - 750	41	39	$3.1 \times 10^5$	$1.8 \times 10^5$
722 - 738	45	43	$3.4 \times 10^5$	$2.0 \times 10^5$

**Figure E-5-9.—Moment capacities (lb-in) of a buttress by elevation.**



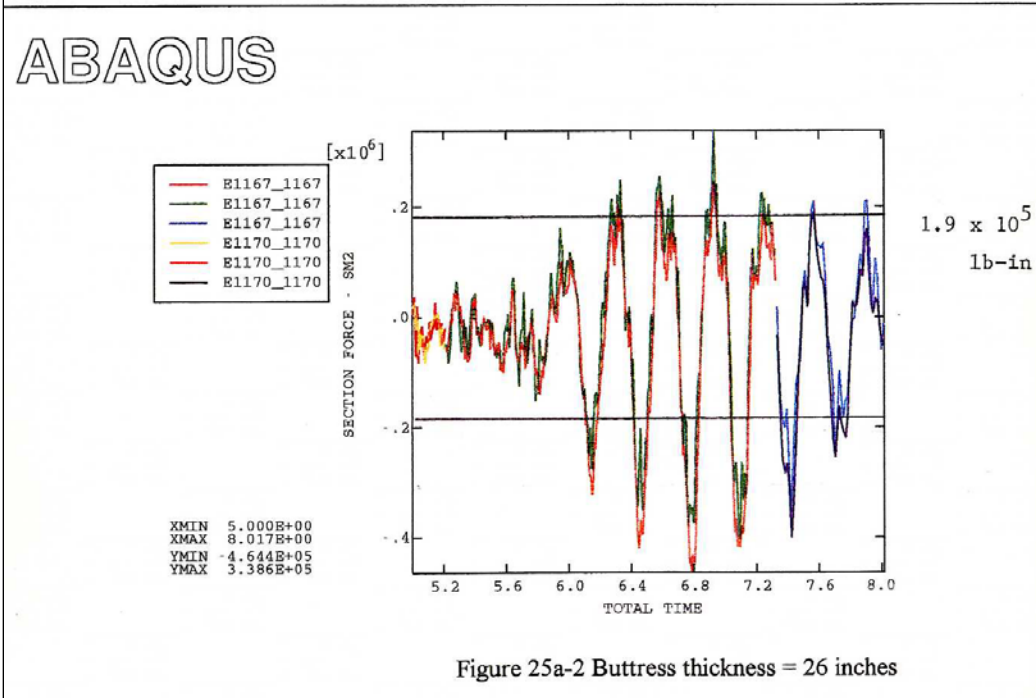
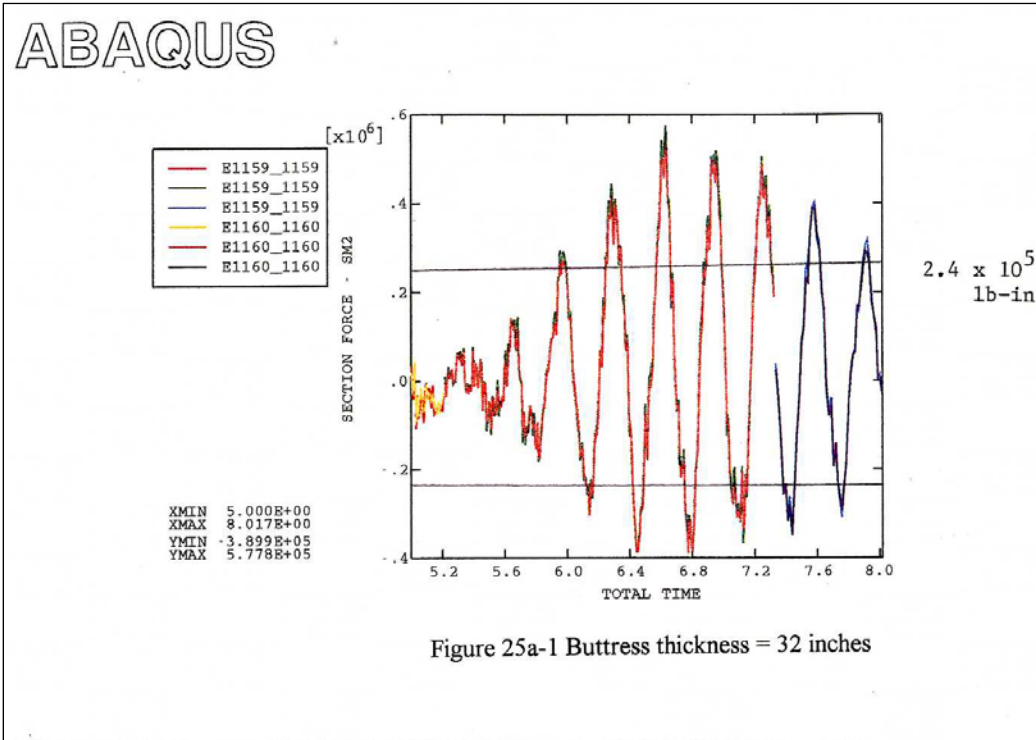

Figure E-5-10.—Buttress seismic moment time histories.

## E-5.7 Displacement Criteria

Even though the tensile capacity of the concrete is exceeded and/or the moment capacity of a member is exceeded, it does not necessarily mean the dam will fail. The reinforcing in the concrete is ductile and can undergo significant displacement before it reaches its ultimate capacity. Again, consideration for the amount of reinforcement is important for the evaluation. For more information on evaluating the reinforcement using displacement criteria, refer to “chapter E-2, Reinforced Concrete Failure Mechanisms.”

## E-5.8 Event Tree

An example event tree for potential failure of a buttress dam due to cross-canyon seismic loading is shown on figure E-5-11. This tree is very general and should be tailored to the understanding of the dam being evaluated. The earthquake load range probabilities are obtained from the seismic hazard curves, as discussed in “chapter B-2, Seismic Hazard Analysis” and “chapter A-5, Event Trees.”

The likelihood of the next node, “Loss of Lateral Support” is evaluated, for example, by examining the number of struts where the load exceeds the capacity and by how much the capacity is exceeded. Where struts are not present, the potential to lose lateral support due to distress to the upstream water retaining members is also evaluated. The likelihood is based largely on subjective estimates (see “chapter A-6, Subjective Probability and Expert Elicitation”) informed by analysis results at various load exceedance probabilities. It is unlikely that lateral support would be lost for massive head buttress dams, since the water retaining members are massive. However, consistency between the numbers estimated and the condition they represent must be maintained.

Given loss of lateral support, the likelihood of a buttress “buckling” or failing due to bending is evaluated by examining the results of the finite element analysis performed with the proper level of lateral support taken out (as represented by the previous node). The methods described in “chapter E-2, Reinforced Concrete Failure Mechanisms” are used to evaluate the likelihood of failure.

Finally, it is important to make some assessment as to how likely it is that multiple buttresses would fail and how many buttresses might fail, given that one buttress fails, as this affects the breach outflow and downstream consequences. As water flows through the opening created by one collapsed buttress, it loads the adjacent buttresses laterally on one side. The buttresses were typically not designed to handle this type of loading, and collapse of adjacent buttresses is possible. Therefore, it is important to have some idea as to where the failure is likely to initiate. Collapse of adjacent buttresses is then possible, typically to the point where the structure becomes more massive, for example, a spillway section with both upstream and downstream slabs or other more massive features, or where thicker buttresses might exist where the structure makes a bend, etc.

### Chapter E-5 Risk Analysis for Concrete Buttress Dams

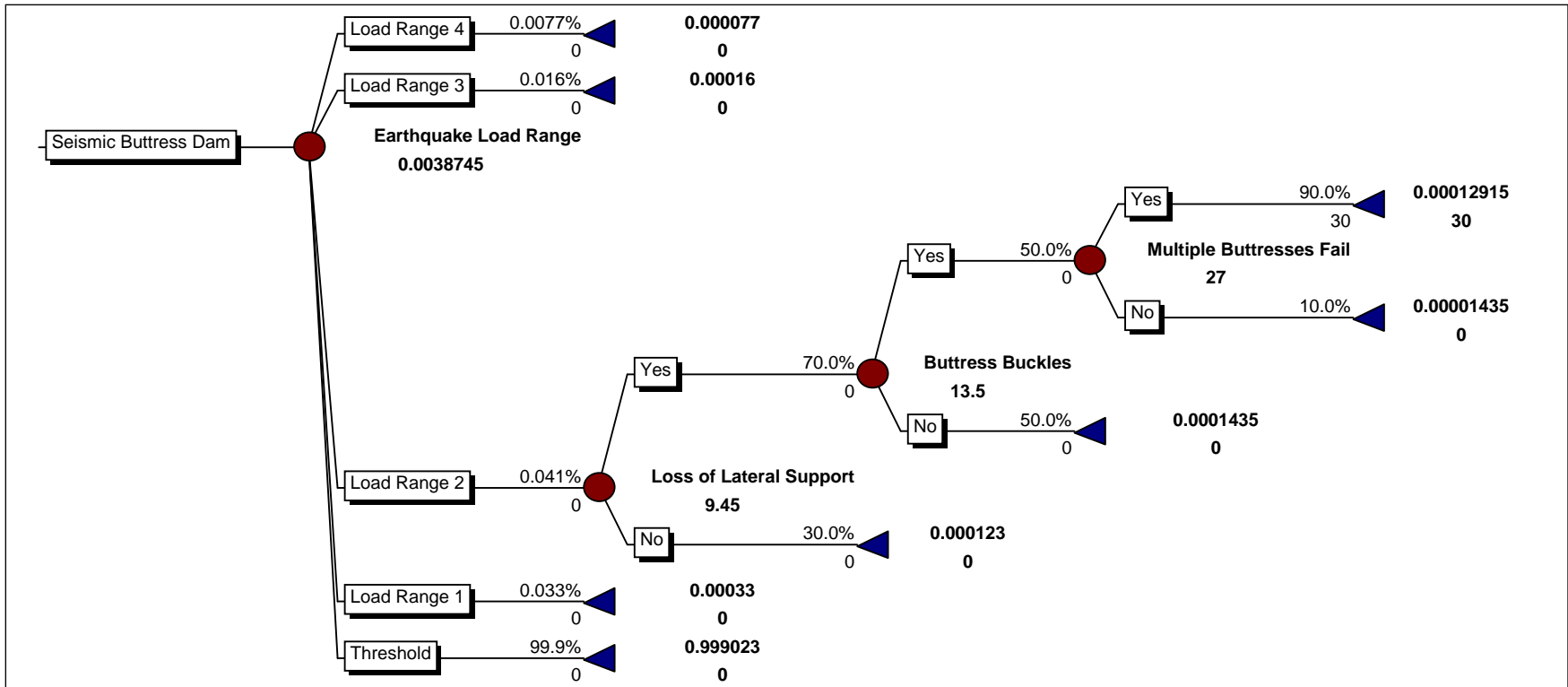

Figure E-5-11.—Event tree for seismic buttress dam evaluation.

## **E-5.9 Accounting for Uncertainty**

Uncertainty is accounted for by estimating a range or distribution of values for each node on the event tree. A Monte-Carlo analysis is then run for the event tree to display the “cloud” of uncertainty, as described in “chapter A-8, Combining and Portraying Risks.”

## **E-5.10 Relevant Case Histories**

### **E-5.10.1 Gleno Dam: 1923**

Although not related to seismic loading, the Gleno Dam case history suggests the importance of properly modeling foundation conditions in the analyses.

Gleno Dam was a 164-foot-high multiple arch dam 30 miles northeast of Bergamo in north central Italy. The dam was over 700 feet long with a curved central portion and buttresses of double thickness at the tangents. A masonry gravity plug containing a 10-foot-wide by 30-foot-high outlet opening was constructed in a deep central valley gorge. The original design called for a gravity dam, but the design was changed and the dam built before the change was approved. Portions of the buttresses on either side of the masonry plug were placed directly on rock with no excavation. The masonry plug was constructed with lime mortar, even though cement mortar had been specified. The concrete used in constructing the arches and buttresses was not of the best quality. Aggregate may have been somewhat dirty, and concrete consolidation was poor in places. Steel reinforcement consisted of scrap grenade netting from World War I.

Leakage through the masonry plug increased as the reservoir filled for the first time, reaching a maximum of 4.5 ft<sup>3</sup>/s. The pool remained full for over a month. Early the morning of December 1, 1923, the dam tender noticed a vertical crack through Buttress No. 11 near the right side of the curved section of the dam. Large pieces of concrete fell and the buttress split in two, followed by collapse of the adjoining arches. Water surged through the opening followed by progressive collapse of the arches and buttresses in the central portion of the dam (Engineering News-Record 1924). A 100-foot-high wall of water swept through the Dezzo River Valley. Power stations, factories, bridges and villages were wiped out, with a reported 356 fatalities.

There were various theories as to why the dam collapsed. The official report concluded that the fundamental cause was associated with the stone masonry base portion of the dam upon which the multiple arch superstructure was founded. It was concluded that collapse started as a result of settlement of the masonry plug (presumably due to leaching of the lime mortar from the leakage). This set up

abnormal stresses in the superstructure which failed at its weakest point, Buttress No. 11. However, it is interesting to note that post-failure photographs show the masonry plug essentially intact. And there are no pre- and post-failure surveys to indicate the extent of the masonry plug settlement. Cracks in the remaining buttresses followed the direction of maximum shear.

### **E-5.10.2 Vega de Tera Dam: 1959**

Again, this case history does not deal with seismic loading, but suggests care must be taken in the modeling and evaluating the design. Vega de Tera Dam was a 112-foot-high slab and buttress dam completed in 1957 on the Tera River in a remote region of northwest Spain. The foundation was competent quartz gneiss, the buttresses were constructed of cement mortared masonry, and the slabs were constructed of reinforced concrete. Following a winter shutdown, it was reported that little attention was paid to lift surface cleanup on the masonry surfaces. Grouting was performed in 1956 to control leakage. The reservoir filled to within 6 feet of maximum level in February 1958, but was essentially empty by October of that year.

In January of 1959, heavy rains filled the reservoir, and the dam is thought to have failed at a joint between the concrete and masonry on a sloping portion of the foundation near the left abutment as the reservoir neared the crest. A 330-foot section of the dam including 17 buttresses failed in rapid succession, stopping at the more massive spillway section near the center of the dam. The town of Rivadelago, about 3 miles downstream and 1700 feet lower in elevation, was nearly completely destroyed. The failure occurred at night and rescue efforts were hampered by the bad weather, resulting in 144 fatalities.

Large-size laboratory tests conducted on the masonry indicated a low modulus value of about  $0.14 \times 10^6$  lb/in<sup>2</sup>. The failure was officially attributed to the low modulus of the buttresses that allowed the slabs to deform and fail at the base in cantilever bending. This put additional shear load on the buttresses, which could not be resisted. However, it is interesting to note that the slabs were not sloping at a great angle (figure E-5-12) and shear loads at the base of the structure would be of concern. Typically, the upstream water retaining elements are sloped at close to 45 degrees. This results in a large vertically downward force from the reservoir loading, which is beneficial since the structure itself doesn't have much weight; a main advantage of a buttress dam is that the loads can be carried with much less concrete than a conventional gravity dam.

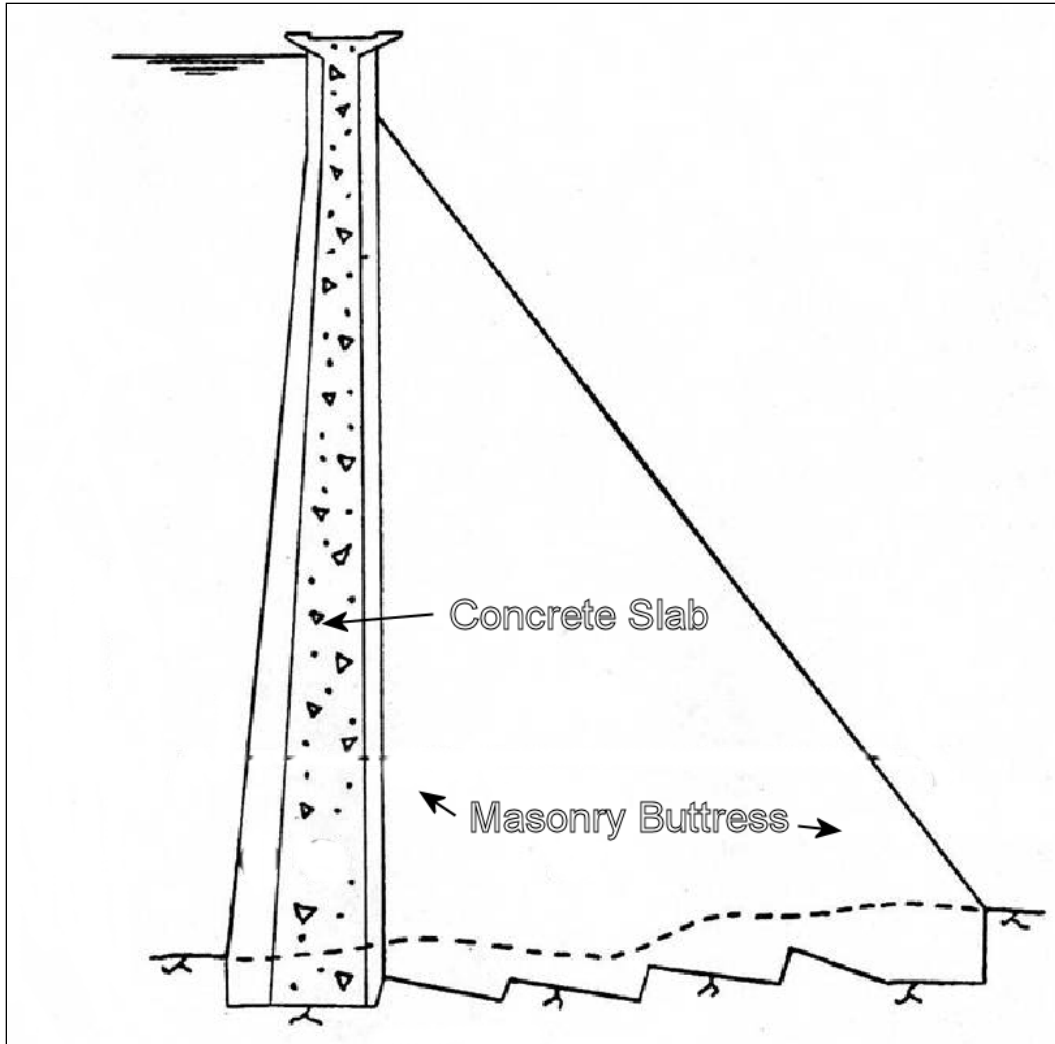

Figure E-5-12.—Cross section of Vega de Tera Dam (adapted from International Commission on Large Dams 1974).

## E-5.11 References

- American Concrete Institute (ACI). 2014. Building Code Requirements for Structural Concrete, ACI 318-14. Reported by ACI Committee 318.
- Engineering News-Record. 1924. Official Report on Collapse of Gleno Dam, pp. 213-215. August 7, 1924.
- International Commission on Large Dams. 1974. "Vega de Tera," *Lessons from Dam Incidents*, Complete Edition, pp. 64-674.
- Sozen, M. 1993. Radial Displacement Tolerance of a Reinforced Concrete Circular Arch. Report to the Bureau of Reclamation, Denver, Colorado. December 28, 1993.

## Chapter E-5 Risk Analysis for Concrete Buttress Dams

Zangar, C.N. 1952. Hydrodynamic Pressures on Dams due to Horizontal Earthquake Effects, Engineering Monograph No. 11. Bureau of Reclamation, Denver, Colorado. May 1952.