

TABLE OF CONTENTS

	Page
D-6	Internal Erosion Risks for Embankments and Foundations.....D-6-1
D-6.1	Key ConceptsD-6-1
D-6.2	Historical BackgroundD-6-1
D-6.3	Physical Location of Internal Erosion CategoriesD-6-2
D-6.4	Processes of Internal Erosion.....D-6-4
D-6.4.1	ScourD-6-5
D-6.4.2	Backward Erosion PipingD-6-7
D-6.4.3	Internal MigrationD-6-9
D-6.4.4	Internal Instability – Suffusion and SuffosionD-6-10
D-6.5	Conceptual Framework for the Internal Erosion ProcessD-6-11
D-6.5.1	Internal Erosion ProcessD-6-11
D-6.5.2	Event TreesD-6-11
D-6.5.3	Physical Locations of Failure Paths and Processes CombinedD-6-13
D-6.6	Loading ConsiderationsD-6-19
D-6.6.1	Dams Operated for Storage.....D-6-19
D-6.6.2	Dams and Levees Operated for Flood Risk ManagementD-6-20
D-6.7	Initiation – Erosion StartsD-6-21
D-6.7.1	Effect of Material Properties on InitiationD-6-22
D-6.7.2	Effect of Hydraulic Conditions on Initiation.....D-6-27
D-6.7.3	Effect of Stress Conditions and Presence of “Flaws or Defects” on Initiation.....D-6-33
D-6.7.4	Approach to Estimating the Probability that Internal Erosion Will InitiateD-6-36
D-6.8	Continuation.....D-6-38
D-6.8.1	ContinuityD-6-39
D-6.8.2	Open ExitD-6-39
D-6.8.3	Filtered/Unfiltered Exit.....D-6-39
D-6.8.4	Constricted (Non-Erodible) Exit.....D-6-41
D-6.9	Progression.....D-6-42
D-6.9.1	Progression – Continuous Stable Roof and/or Sidewalls.....D-6-43
D-6.9.2	Progression – Constriction or Upstream Zone Fails to Limit Flows.....D-6-44
D-6.9.3	Progression – No Self-Healing Provided by Upstream Zone.....D-6-45

	Page
D-6.9.4	Unsuccessful Intervention.....D-6-46
D-6.9.5	Assessing the Rate of Enlargement of a PipeD-6-48
D-6.9.6	BreachD-6-50
D-6.9.7	Accounting for UncertaintyD-6-53
D-6.9.8	Relevant Case HistoriesD-6-53
D-6.9.9	ExampleD-6-60
D-6.10	References.....D-6-60
D-6.10.1	Other ResourcesD-6-69

Tables

	Page
D-6-1	Piping Resistance of Soils (adapted from Sherard 1953)D-6-26
D-6-2	Erosion Resistance of Soils from Concentrated Leaks (Scour) (adapted from ICOLD 2015)D-6-26
D-6-3	Probability of Holding a Roof (adapted from Fell et al. 2008)D-6-44
D-6-4	Rate of Erosion of the Embankment Core or Foundation Soil (adapted from Fell et al. 2001, 2003)D-6-49
D-6-5	Rate of Erosion of the Embankment Core or Foundation Soil (used in table D-6-4) (adapted from Fell et al. 2008).....D-6-49
D-6-6	Influence of the Material in the Downstream Zone of the Embankment on the Likely Time for Development of a Breach due to Gross Enlargement of a Pipe (used in table D-6-4) (adapted from Fell et al. 2003)D-6-50
D-6-7	Qualitative Terms for Times of Development of Internal Erosion and Breach (adapted from Fell et al. 2003)D-6-50

Figures

	Page
D-6-1	Internal erosion through the embankment.D-6-2
D-6-2	Internal erosion through the foundation.....D-6-3
D-6-3a	Internal erosion of the embankment into the foundation.D-6-3
D-6-3b	Internal erosion along the embankment-foundation contact.....D-6-3
D-6-4	Internal erosion along or into embedded structures (adapted from FEMA 2005, 2008, and Fell et al. 2008).....D-6-4
D-6-5	Concentrated leak erosion (courtesy of Mark Foster).....D-6-6
D-6-6	Hydraulic fracture (courtesy of Mark Foster).....D-6-6
D-6-7	Contact erosion process (Construction Industry Research and Information Association 2013).D-6-8
D-6-8	Possible locations of initiation of contact erosion (Béguin et al. 2009).....D-6-8
D-6-9	BEP (adapted from van Beek et al. 2011).....D-6-9
D-6-10	Internal migration.....D-6-10
D-6-11	Internal instability (suffusion) (adapted from Ziembs 1969).....D-6-11
D-6-12	Internal erosion through the embankment initiated by a concentrated leak (adapted from Fell et al. 2008).....D-6-12
D-6-13	Example of event tree for concentrated leak erosion.....D-6-14
D-6-14	Example of event tree for BEP.D-6-15
D-6-15	Factors affecting the initiation of internal erosion (adapted from Garner and Fannin 2010 and ICOLD 2015).D-6-22
D-6-16	Soils susceptible to BEP (de Wit et al. 1981; Townsend and Shiau 1986; van Beek et al. 2008; 2009).D-6-23
D-6-17	Potentially internally unstable soils (adapted from Wan and Fell 2004a).D-6-24
D-6-18	Potentially internally unstable soils (Sherard 1979 and Reclamation 2011).....D-6-24
D-6-19	Heave at the toe of an embankment (Pabst et al. 2012)..... 28
D-6-20	Uplift and/or blowout at the toe of an embankment (Pabst et al. 2012).D-6-29
D-6-21	Critical sand boil locations along Mississippi River levees (adapted from Ammerlaan 2007).....D-6-31
D-6-22	Failure mode in-progress (not to scale).D-6-57
D-6-23	Example.D-6-60

Appendices

- D-6-A Large Dam Failure Statistics
- D-6-B Historical Frequencies
- D-6-C Concentrated Leak Erosion
- D-6-D Soil Contact Erosion
- D-6-E Critical Gradients for Evaluation of Backward Erosion Piping
- D-6-F Internal Instability (Suffusion)
- D-6-G Detailed List of Conditions which Increase the Likelihood of Initiation of an Internal Erosion Process
- D-6-H Continuation
- D-6-I Rate of Enlargement of a Pipe
- D-6-J Tables of More and Less Likely Factors for Different Categories of Internal Erosion

List of Appendix D-6-J Tables

- D-6-J-1 Factors Influencing the Likelihood of Initiation of Internal Erosion Through an Embankment Dam
- D-6-J-2 Factors Influencing the Likelihood of Continuation of Internal Erosion
- D-6-J-3 Factors Influencing the Likelihood of Progression of Internal Erosion
- D-6-J-4 Factors Influencing the Likelihood that Intervention Fails for Internal Erosion
- D-6-J-5 Factors Influencing the Likelihood of Dam Breach
- D-6-J-6 Factors Influencing the Likelihood of Initiation of Internal Erosion through the Foundation
- D-6-J-7 Factors Influencing the Likelihood of Initiation of Internal Erosion of Embankment into Foundation

List of Appendix D-6-J Tables (continued)

D-6-J-8 Factors Influencing the Likelihood of Initiation of Internal Erosion
Into or Along a Conduit

D-6-J-9.—Factors Influencing the Likelihood of Initiation of Internal Erosion into
Drains

D-6 INTERNAL EROSION RISKS FOR EMBANKMENTS AND FOUNDATIONS

D-6.1 Key Concepts

One of the leading causes of dam and levee failures in the United States is from internal erosion of embankments (or their foundations). Unfortunately, this is a potential failure mode that cannot be completely analyzed using numerical formulae or models. However, valuable information on embankment and foundation characteristics and behavior is available to help in assessing internal erosion risks. The term “internal erosion” is used as a generic term to describe erosion of soil particles by water passing through a body of soil. “Piping” is often used generically in the literature but refers to a specific internal erosion mechanism (described in “section D-6.4.2, Backward Erosion Piping.”

D-6.2 Historical Background

Based on the records of dam incidents and the dam register in International Commission on Large Dams (ICOLD) 1974, 1995), Foster et al. (1998, 2000) evaluated the statistics of failure of large dams constructed between 1800 and 1986, excluding dams constructed in Japan before 1930 and in China. Approximately one-half of the cases of failure in operation were the result of internal erosion. The results are summarized in table D-6-A-1 in “appendix D-6-A, Large Dam Failure Statistics” by the location of where internal erosion occurred. In this evaluation the three locations used were through the embankment, through the foundation, and from the embankment into the foundation. The largest number of internal erosion failures occurred through the embankment, and nearly one-half of these were associated with conduits or walls which penetrate the embankment. Approximately two-thirds of all failures and one-half of all accidents¹ occurred on first-filling or in the first 5 years of reservoir operation. Therefore, approximately one-half of all incidents included in this evaluation occurred after 5 years of reservoir operation. Foster et.at. (1998, 2000) also found that nearly all internal erosion failures located through the embankment occurred when the reservoir level was at or near (within one meter) the pool of record. Excluding conduits and spillways, 63 percent of the incidents were associated with cracking, and 37 percent were associated with poorly

¹ Failure is collapse or movement of the dam or foundations such that water retention capability is lost, an accident is an event that was prevented from becoming a failure by remedial measures, and an incident is either a failure or accident (ICOLD 1974).

Chapter D-6 Internal Erosion Risks for Embankments and Foundations

compacted and high permeability zones (Foster et al. 1998, 2000). Additional statistics from this study are provided in “appendix D-6-A, Large Dam Failure Statistics,” including:

- The historical frequencies of failures and accidents (table D-6-A-2).
- The timing of the incidents for internal erosion through the embankment (table D-6-A-3) and for internal erosion through the foundation (table D-6-A-4).
- A further assessment of the case study information for incidents of cracking and hydraulic fracturing in the embankment (table D-6-A-5) and for incidents of poorly compacted and high permeability zones (table D-6-A-6).

D-6.3 Physical Location of Internal Erosion Categories

As mentioned above internal erosion cases have been grouped into the following general categories related to the physical location of the internal erosion pathways in order to further evaluate internal erosion failure modes:

- Internal erosion through the embankment (figure D-6-1)
- Internal erosion through the foundation (figure D-6-2)
- Internal erosion of the embankment into the foundation (figure D-6-3a), including along the embankment-foundation contact (figure D-6-3b)

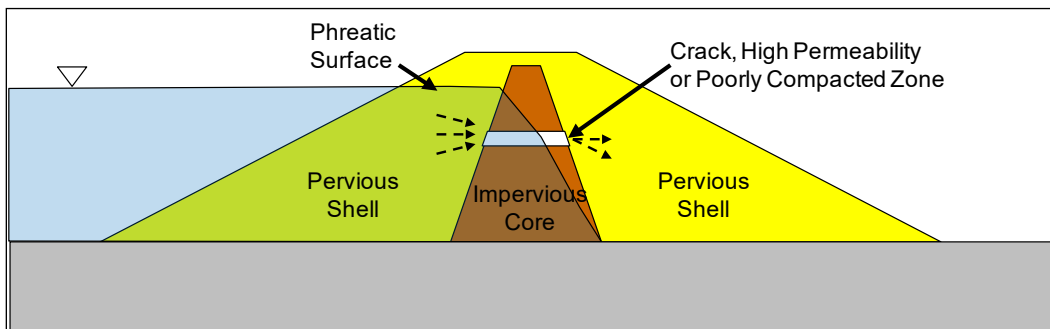

Figure D-6-1.—Internal erosion through the embankment.

Chapter D-6 Internal Erosion Risks for Embankments and Foundations

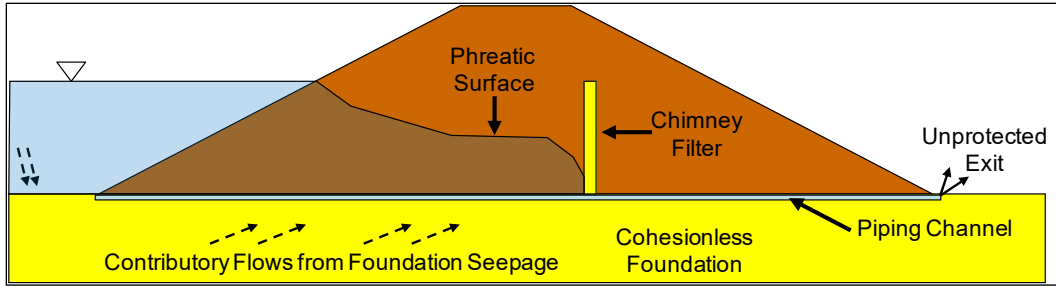

Figure D-6-2.—Internal erosion through the foundation.

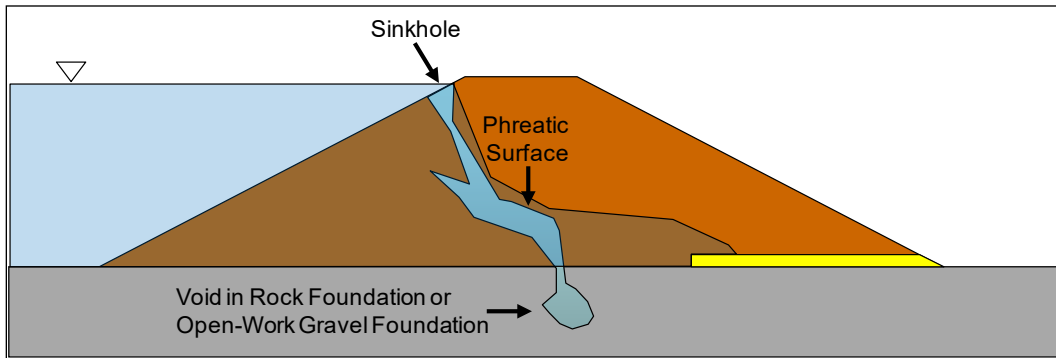

Figure D-6-3a.—Internal erosion of the embankment into the foundation.

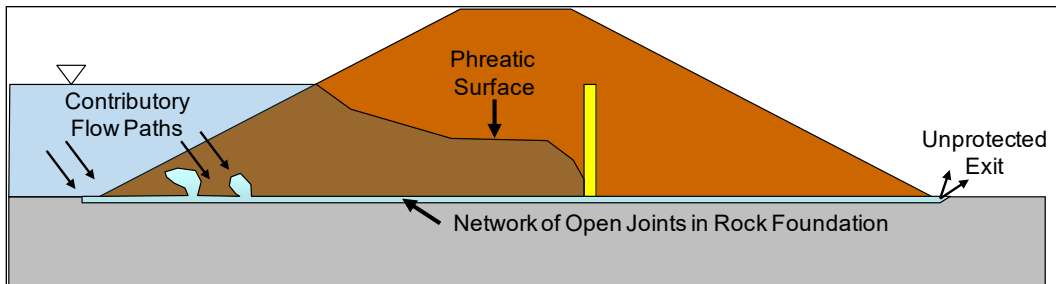

Figure D-6-3b.—Internal erosion along the embankment-foundation contact.

In addition to the general categories listed above, others added the following two locations when developing statistics from their internal erosion case history database (Engemoen 2017), as described in “appendix D-6-B, Historical Frequencies”:

- Internal erosion along or into embedded structures such as conduits or spillway walls (figure D-6-4)
- Internal erosion into drains such as toe drains, stilling basin underdrains, etc.

Chapter D-6 Internal Erosion Risks for Embankments and Foundations

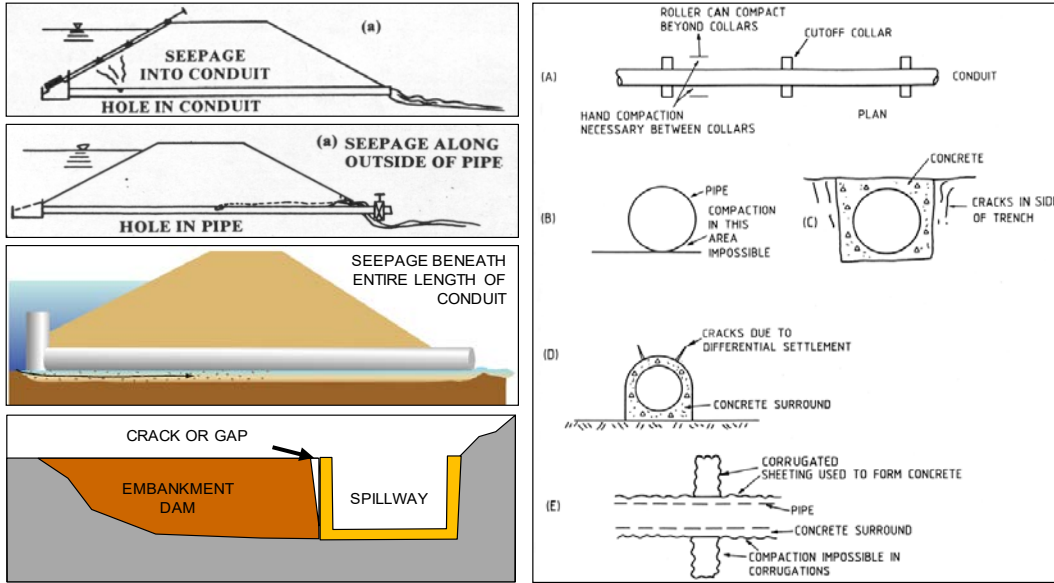

Figure D-6-4.—Internal erosion along or into embedded structures (adapted from FEMA 2005, 2008, and Fell et al. 2008).

It is important to note that no dam failures have occurred as a result of internal erosion into drains. This is most likely because this potential failure mode would take a long time to develop, and case histories indicate intervention through early detection has been successful in stopping the internal erosion process. The stilling basin case history described at the end of this chapter is an example of internal erosion into drains.

The locations of internal erosion identified here are **not** potential failure mode descriptions. The potential failure mode should be identified based on site-specific information and clearly described in detail from initiation to breach. It is important to identify where the failure path will likely form, where erosion first initiates, where the soil particles will be carried, how the erosion will progress, opportunities for detection and intervention, and how the embankment will breach.

D-6.4 Processes of Internal Erosion

Whereas the previous discussion centered on the locations of internal erosion cases, the following discussion describes the specific internal erosion “mechanisms” and processes that have been observed in case histories. The term “process” describes more phases of internal erosion than just the initiating mechanisms.

Organizations that have studied internal erosion incidents have observed several different mechanical processes and have classified those incidents by various

Chapter D-6 Internal Erosion Risks for Embankments and Foundations

mechanism or processes to establish some degree of common terminology along with an understanding of the physical factors associated with each type of internal erosion. Those evaluating internal erosion should consider the specific mechanics of the potential failure modes envisioned at a specific site and provide a full description of the entire process, regardless of the mechanism name. The general processes to consider are:

- Scour (concentrated leak erosion and soil contact erosion)
- BEP
- Internal migration (stopping)
- Internal instability (suffusion and suffosion)

Flaws and other physical factors that can lead to an internal erosion failure mode and guidance for evaluating the probability of initiation of internal erosion are discussed in this chapter. Each of these processes are described below in detail.

D-6.4.1 Scour

“Subsurface erosion initiated by scour” was used by Terzaghi et al. (1996) in the latest edition of *Soil Mechanics in Engineering Practice* to describe the internal erosion process that occurred at Teton Dam in Idaho. Scour is most likely to occur at or near the contact of an embankment with a jointed rock foundation, in cracks/defects in embankment fill, along conduits, and through transverse cracks near the top of an embankment.

This mechanism occurs when tractive seepage forces along a surface (e.g., a crack within the soil, adjacent to a wall or conduit, along the embankment-rock foundation contact) are sufficient to move soil particles into an unprotected area or at the interface of a coarse and fine layer in the embankment or foundation. This mechanism does not necessarily imply a backward (toward impounded water) development of an erosion pathway. Enlargement of an existing defect may occur anywhere along the seepage pathway and will occur first where the combination of hydraulic shear stresses and erodibility are most adverse.

Two subsets of this category include concentrated leak erosion and soil contact erosion.

D-6.4.1.1 Concentrated Leak Erosion

Sherard (1973) used the term “concentrated leak” to describe the flow out of cracks that extended through an embankment to distinguish this from seepage that flows through the pores of intact soil. Where there is an opening through which concentrated leakage occurs, the walls of the opening may be eroded by the leaking water as shown on figure D-6-5. Examples of such concentrated leaks

Chapter D-6 Internal Erosion Risks for Embankments and Foundations

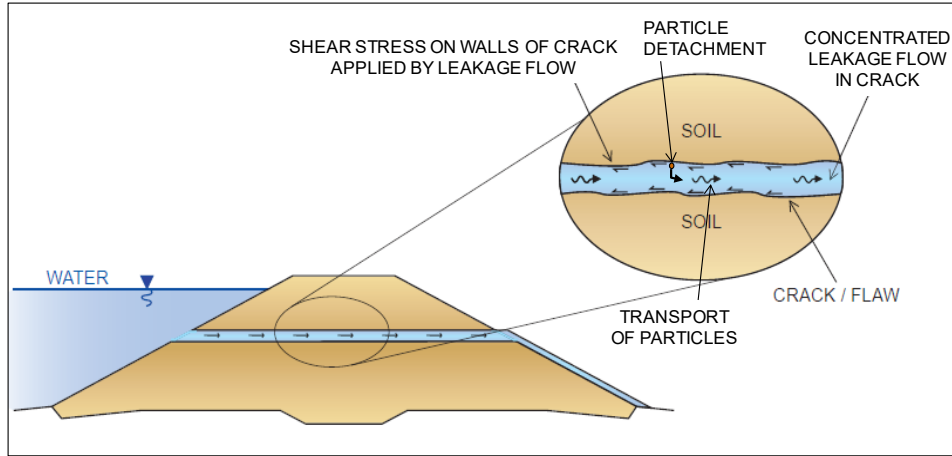

Figure D-6-5.—Concentrated leak erosion (courtesy of Mark Foster).

include through a crack caused by settlement or hydraulic fracture (figure D-6-6) in a cohesive clay core, desiccation and tension cracks at higher levels in the embankment, cracks resulting from differential settlement of the embankment, or through bedrock discontinuities that erode adjacent embankment materials. Many of the situations in which concentrated leaks may occur are depicted on figures provided in “appendix D-6-C, Concentrated Leak Erosion.” In some circumstances, these openings may be sustained by the presence of structural elements (e.g., spillways or conduits) or by the presence of cohesive materials able to “hold a roof” below which an opening is sustained and the periphery of which is eroded. It may also occur in a continuous zone containing coarse and/or poorly compacted materials which form a system of interconnected voids. The concentration of flow causes erosion (i.e., scour) of the walls of the crack or interconnected voids.

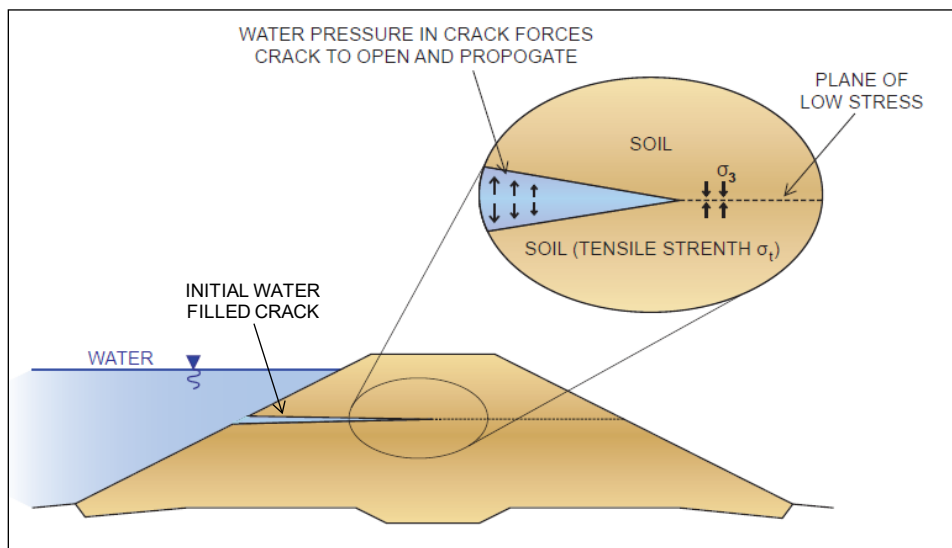

Figure D-6-6.—Hydraulic fracture (courtesy of Mark Foster).

D-6.4.1.2 Soil Contact Erosion

Soil contact erosion describes the process in which a fine-grained soil is in contact with an open-work gravel, and flow parallel to the contact erodes the fine soil into and through the gravel. It is similar to concentrated leak erosion through a crack, but the flow is occurring through a gravel which is scouring fine materials in contact with the gravel. It is considered separately because there are specific methods that can be used to assess the likelihood based on: (1) the use of filter criteria to determine if erosion of the fines into the gravel is possible (i.e., not filtered) and (2) estimate if predicted velocities are high enough in the gravel to detach and transport fine particles. These methods differ from those used to assess scour in a crack mainly because the hydraulics of the flow are more complex in a gravel layer. The field conditions necessary for this process to occur are not common. The cases that led to the laboratory testing of this process were apparently a result of silt fill placed in contact with open-work gravel resulting in sinkholes or subsidence in some levees. The situation where the fine-grained soil is located over the gravel has been found to be much worse than the inverse as shown on figure D-6-7. If soil contact erosion initiates, it could lead to one of the other processes identified in this chapter such as internal migration. It can lead to the formation of a roof at the interface, sinkhole development, creation of a weaker zone leading to slope instability, or clogging of permeable layers and increase in pore water pressure. Figure D-6-8 depicts some possible locations that contact erosion could develop.

D-6.4.2 Backward Erosion Piping

BEP occurs when soil erosion (particle detachment) begins at a seepage exit point and erodes backwards (towards the impounded water), supporting a “pipe” or “roof” along the way. As the erosion continues, the seepage path gets shorter, and flow concentrates in plan view, leading to higher gradients, more flow, and higher potential for erosion to continue. Four conditions must exist for BEP to occur: (1) flow path or source of water, (2) unprotected or unfiltered exit, (3) erodible material within the flow path, and (4) continuous stable roof forms allowing a pipe to form. BEP is particularly dangerous because it involves progression of a subsurface pipe towards the impounded water until a continuous pipe is formed, as shown on figure D-6-9.

BEP occurs in cohesionless soils or those with a low plasticity index (PI). It mainly occurs in foundations due to the potential for continuous low-density deposits and gradients sufficient to initiate particle movement but may occur within embankments. The erosion process begins at a free surface on the landside or downstream side of the embankment. For BEP in the foundation, the free surface may be the ground surface, a ditch at the embankment toe, the stream bed further downstream of the embankment, or a defect in a confining layer (e.g., due to desiccation cracking, uplift or blowout, animal burrows, excavation, or other

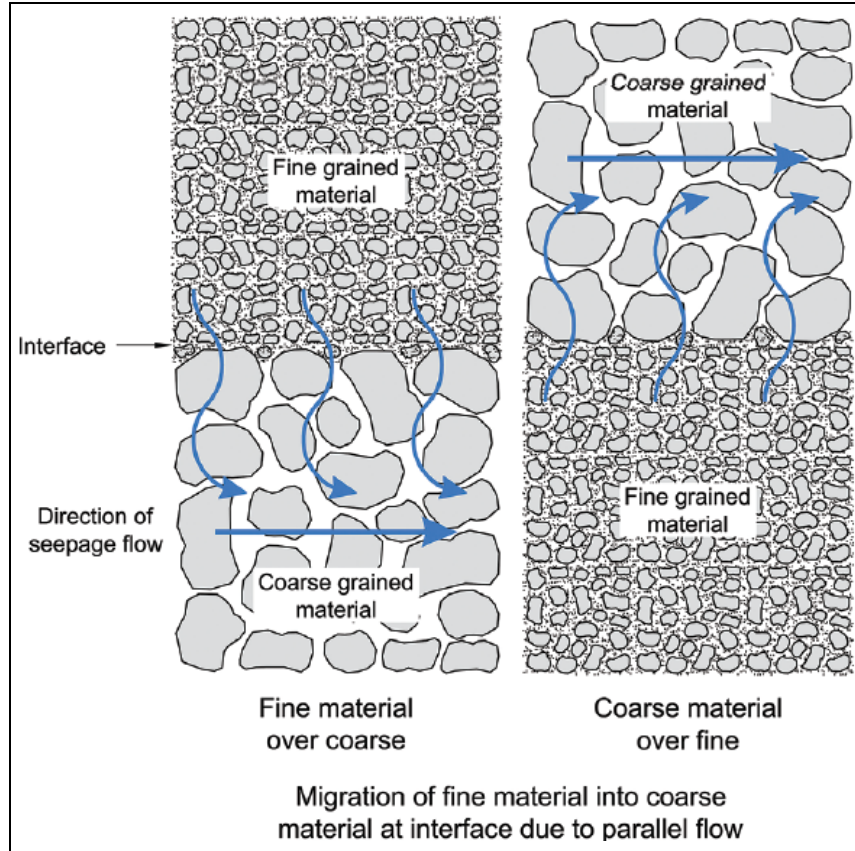

Figure D-6-7.—Contact erosion process (Construction Industry Research and Information Association 2013).

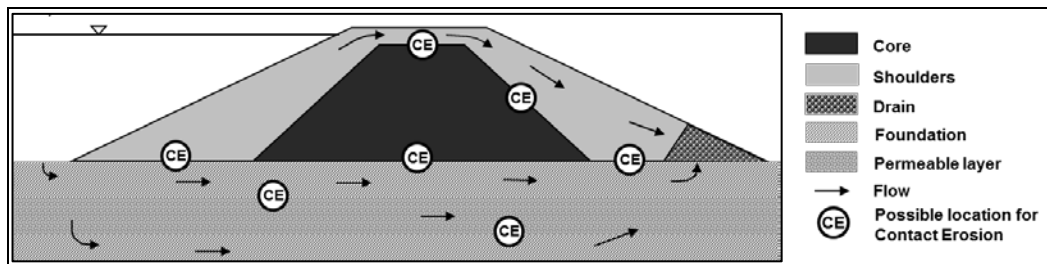

Figure D-6-8.—Possible locations of initiation of contact erosion (Béguin et al. 2009).

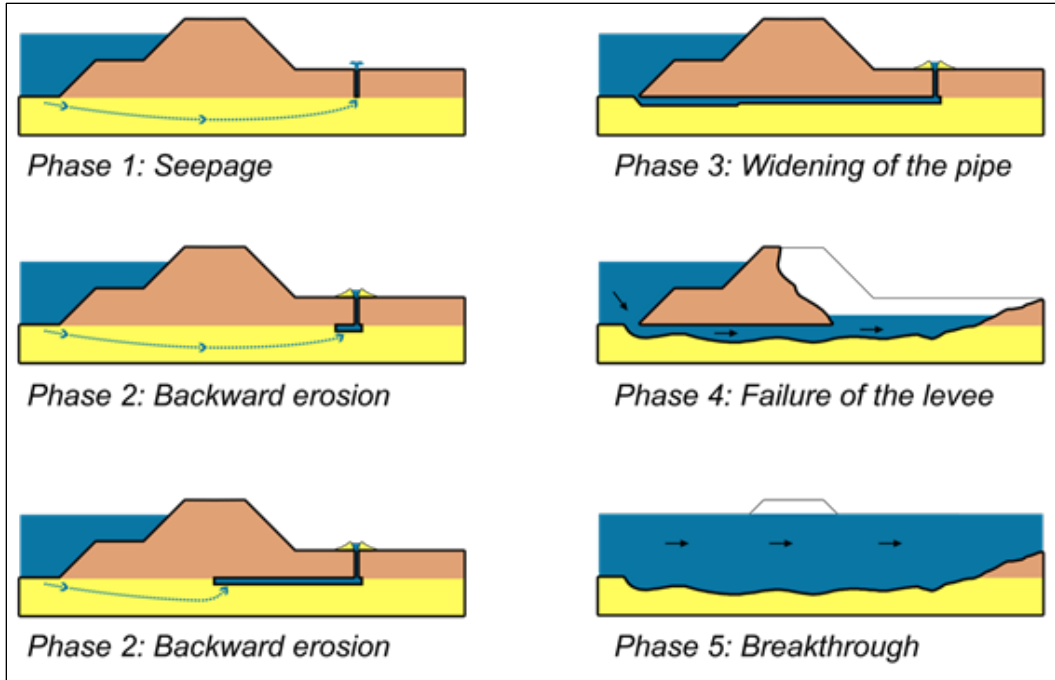

Figure D-6-9.—BEP (adapted from van Beek et al. 2011).

penetrations). BEP is often manifested by the presence of sand boils. Seepage and sand boils can represent a wide spectrum of potential conditions and risks (Von Thun 1996). Piping will develop when there is enough pressure and the supply of water from the pervious layer is sufficient. However, this implies the erosion will be slow when the pressure head which has caused the sand boil is sufficiently dissipated by the increased flow through the boil, similar to the effect of a relief well. For BEP in the embankment, the free surface may be an unfiltered or inadequately filtered zone downstream of the core.

D-6.4.3 Internal Migration

Internal migration occurs when the soil is not capable of sustaining a roof or pipe. Soil particles move or drop into an unfiltered exit and a void grows until the temporary roof can no longer be supported. Soil particles that drop to the bottom of the void are carried away by seepage through the unfiltered exit. This mechanism is repeated progressively causing the void to enlarge and migrate vertically upward. These voids can develop in both saturated and unsaturated environments and typically result in formation of a sinkhole on the surface of the embankment. Soil particles migrate downward primarily due to gravity, but may be aggravated by seepage or precipitation, and a temporary void grows in the vicinity of the initiation location until a roof can no longer be supported; at which time the void collapses. This mechanism typically leads to a void that may stope

Chapter D-6 Internal Erosion Risks for Embankments and Foundations

to the surface as a sinkhole. Stopping can occur in narrow central core dams constructed with broadly graded cohesionless soils (e.g., glacial till) due to internal instability/suffusion, or in other embankments due to open defects in rock foundations or structures embedded in the embankment. This mechanism may be repeated progressively until the core is breached or the downstream or landside slope of a levee is over-steepened to the point of instability.

This could be a slow-developing potential failure mode, and successful intervention is likely if the void manifests above the water surface or the downstream or landside slope. The most critical location for a void to form is beneath the impounded water, as this opens up the potential to introduce full hydraulic head to a more downstream location. Figure D-6-10 depicts the potential locations over an inadequately filtered exit where internal migration could initiate.

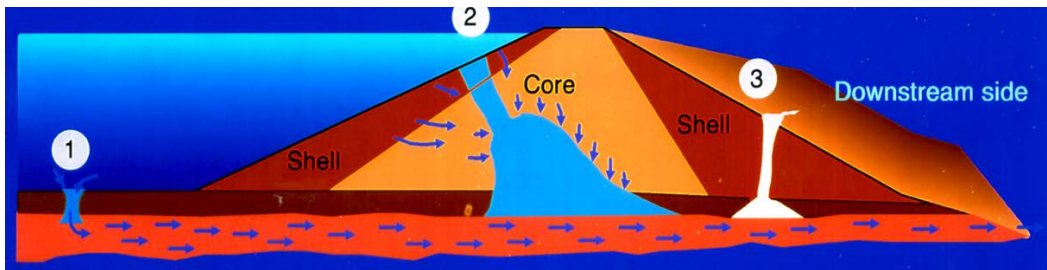

Figure D-6-10.—Internal migration.

ICOLD (2015) describes a stopping process as global backward erosion and considers this a subset of BEP.

D-6.4.4 Internal Instability – Suffusion and Suffosion

Suffusion and suffosion are both internal erosion mechanisms that can occur with internally unstable soils. It is more likely for these mechanisms to occur in complex glacial environments where tills, glacio-lacustrine, and outwash deposits co-exist, or in embankment zones constructed of these materials.

Suffusion is a form of internal erosion which involves selective erosion of finer particles from the matrix of coarser particles of an internally unstable soil, in such a manner that the finer particles are removed through the voids between the larger particles by seepage flow, leaving behind a soil skeleton formed by the coarser particles, as shown on figure D-6-11. Suffusion results in an increase in

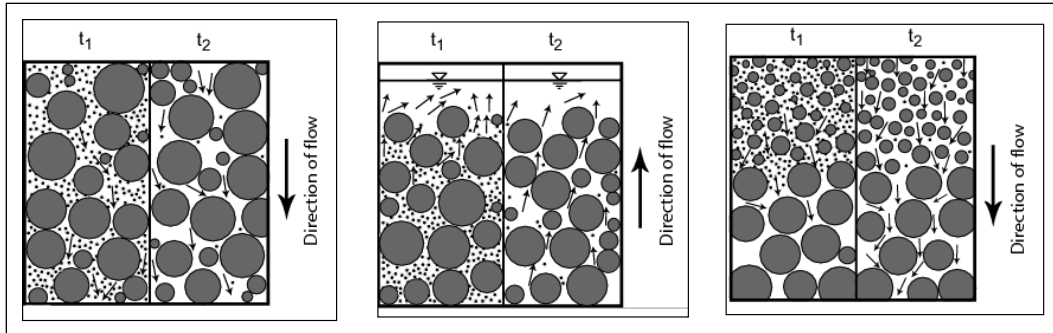

Figure D-6-11.—Internal instability (suffusion) (adapted from Ziems 1969).

permeability (greater seepage velocities and potentially higher hydraulic gradients) and possibly initiation of other internal erosion mechanisms into/along the remnant coarser soil skeleton.

Suffosion is a similar process but results in volume change (voids leading to sinkholes or deformation of overlying embankment materials) because the coarser particles are not in point-to-point contact. Suffosion is less likely under the stress conditions and gradients typically found in embankment dams. This condition might require consideration of BEP, cracking and concentrated leak erosion, or soil contact erosion.

D-6.5 Conceptual Framework for the Internal Erosion Process

D-6.5.1 Internal Erosion Process

The process of internal erosion has been generally broken into four phases: (1) initiation of erosion (particle detachment), (2) continuation of erosion (inadequate particle retention), (3) progression of erosion (continuous particle transport and enlargement of erosion pathway), and (4) initiation of a breach. As an example, the first three phases of a case of scour initiating a failure mode through a zoned embankment are illustrated on figure D-6-12.

D-6.5.2 Event Trees

A generic sequence of events has been developed for analyzing internal erosion failure modes that is based on the four phases of internal erosion. In addition, a threshold water surface elevation (or several different ranges of elevations) and the likelihood of unsuccessful detection and/or intervention are assessed. These

Chapter D-6 Internal Erosion Risks for Embankments and Foundations

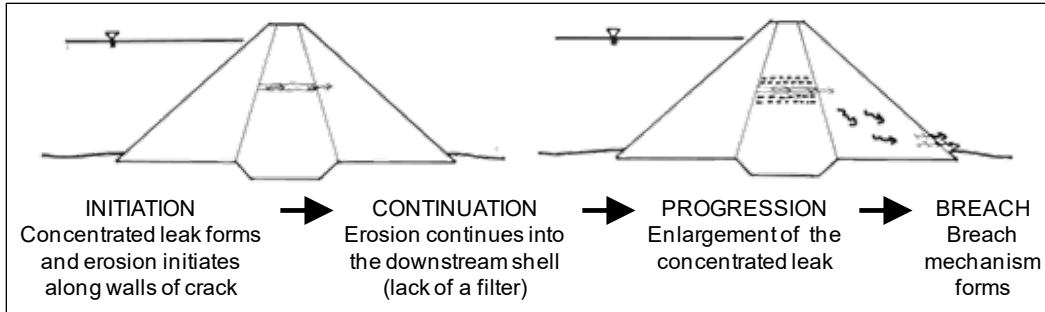

Figure D-6-12.—Internal erosion through the embankment initiated by a concentrated leak (adapted from Fell et al. 2008).

sequences of events can be illustrated as an event tree as follows (consequences are also evaluated for each event tree as discussed in “chapter C-1, Consequences of Dam or Levee Failure”):

- ↳ Water level at or above threshold level
 - ↳ Initiation – Erosion starts
 - ↳ Continuation – Unfiltered or inadequately filtered exit exists
 - ↳ Progression – Continuous stable roof and/or sidewalls
 - ↳ Progression – Constriction or upstream zone fails to limit flows
 - ↳ Progression – No self-healing by upstream zone
 - ↳ Unsuccessful detection and intervention
 - ↳ Breach (uncontrolled release of impounded water)

This event tree is applicable to scour related erosion through a zoned embankment. For other types of internal erosion processes, not all events may apply depending on the postulated failure progression and other site-specific factors. In addition, depending on how the potential failure mode is envisioned and, on the information available, it might be appropriate to decompose the initiation event into two events: 1) flaw exists; and 2) erosion initiates given the flaw exists.

- ↳ Water level loading (at or above threshold level)
 - ↳ Flaw exists – Continuous crack, high permeability zone, zones subject to hydraulic fracture, etc.
 - ↳ Initiation – Erosion starts
 - ↳ See the above event tree for other events that apply

The two-event approach is typically used for projects designed to include flood risk management and which have not been fully loaded. This allows the identification of scenarios where the likelihood of a flaw may be a primary factor in the risk estimate. The quantification of these events can provide a better understanding of how a flaw impacts both the estimate and the uncertainty in

Chapter D-6 Internal Erosion Risks for Embankments and Foundations

the risk estimate. When using historical base rates to estimate initiation (discussed in “appendix D-6-B, Historical Frequencies”), the one-event approach is typically used, as historical rates of a flaw existing where erosion has not initiated are unknown.

More details are provided later in this chapter, as well as the detailed tables listing numerous factors to consider for each event included in “appendix D-6-J, Tables of More and Less Likely Factors for Different Categories of Internal Erosion.” Sample event trees for concentrated leak erosion and BEP are provided on figures D-6-13 and 14. These examples illustrate the two-event approach. If the one-event approach is used, the first two events (flaw and initiation) would be replaced by a single event representing initiation.

The risk team should develop specific event trees for their identified potential failure modes. Sketches of the events on actual cross sections of the embankment and foundation can aid a team in conceptualizing each event in a potential failure mode and convey the information to decisionmakers.

D-6.5.3 Physical Locations of Failure Paths and Processes Combined

Based on all available information on the dam, the risk team will combine the physical locations of potential failure paths along with the potential process or mechanism likely at these locations. In many cases it will be a potential condition associated with natural soil deposits or bedrock upon which the embankment is founded or abutted, and in some cases, it will be a potential condition in the embankment such as a crack or defect. The following is a short list of historic combinations along with some case histories that may be helpful to consider (every condition is not listed):

- **Through the embankment.**—These have typically been attributed to flaws, defects or cracks that were identified or suspected to be caused by embankment conditions, foundation conditions or both. About 7 percent of the Bureau of Reclamation’s (Reclamation) dam incidents occurred at this location.
 - Caused by embankment conditions:
 - Cross section details (scour, BEP, internal migration).—Avalon Dam in New Mexico is possibly a case of a severe incompatibility between earthfill and rockfill leading BEP. Details are provided at the end of the chapter.

Chapter D-6 Internal Erosion Risks for Embankments and Foundations

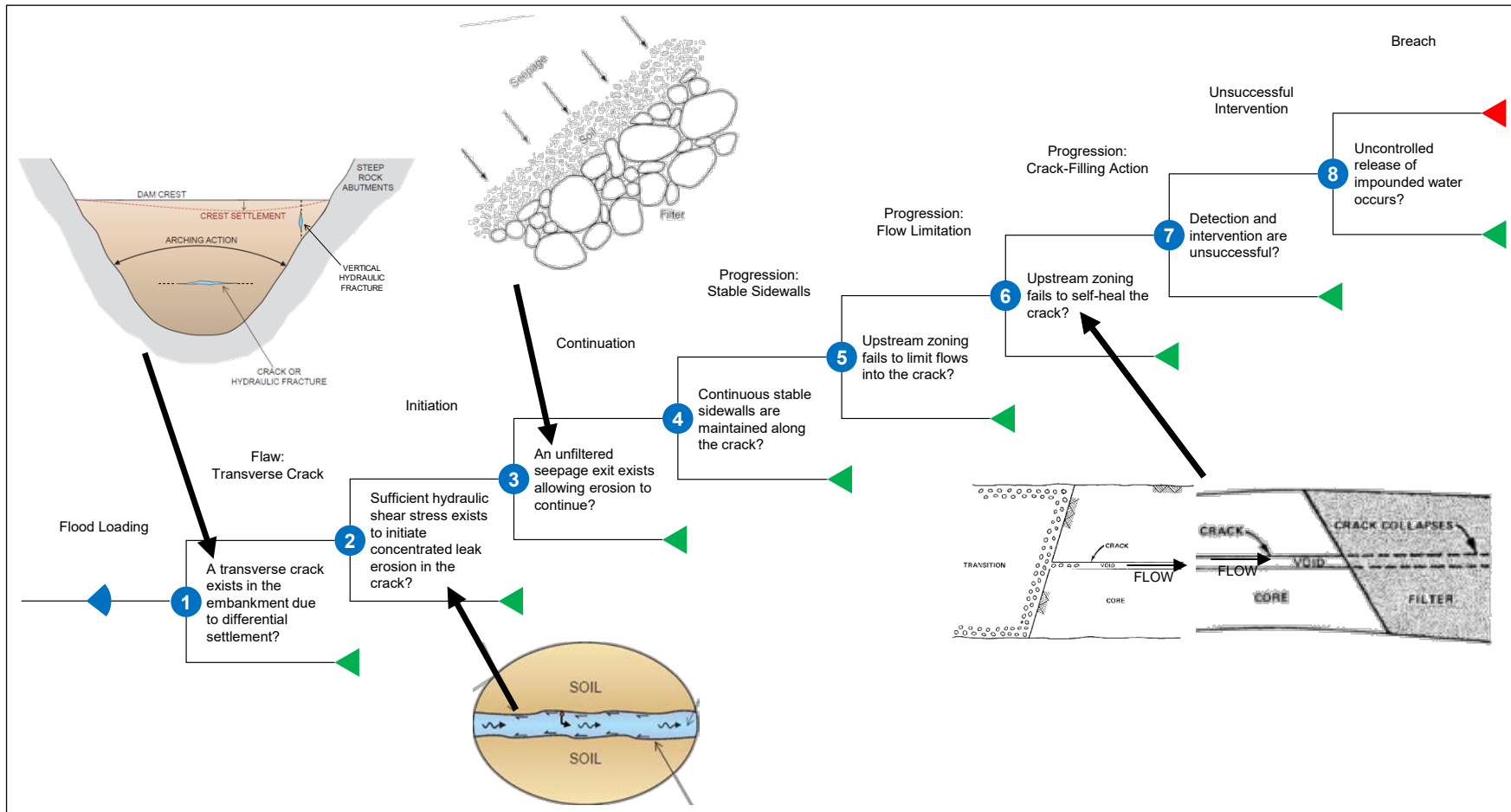

Figure D-6-13.—Example of event tree for concentrated leak erosion.

Chapter D-6 Internal Erosion Risks for Embankments and Foundations

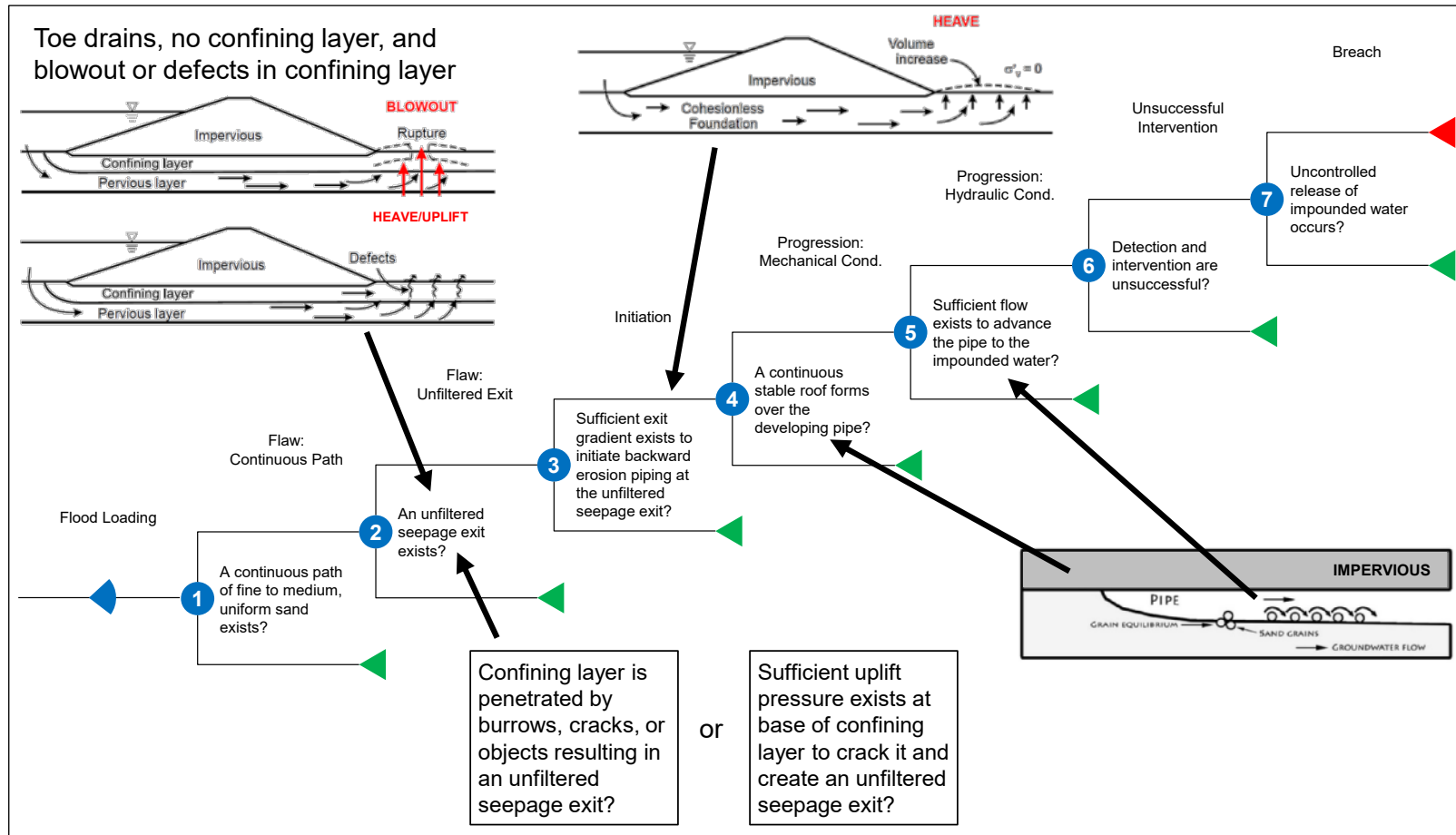

Figure D-6-14.—Example of event tree for BEP.

Chapter D-6 Internal Erosion Risks for Embankments and Foundations

- Construction related (Scour, internal instability).—Poor compaction can lead to excessive settlement and cracking. Segregation can occur as the result of construction practices. Poorly treated layer associated with shutdowns of the fill operations can also lead to defects.
 - Rodent holes, tree roots, (BEP, scour, internal migration).—A canal failure in Nevada was possibly a result of rodent holes as discovered in sections still remaining. Scour could have initiated in holes fully penetrating or partially penetrating holes could have resulted in BEP.
 - Desiccation or freeze-thaw cracks (scour).—Cracking or high permeability layers can occur near the crest if of susceptible soils are inadequate protected.
 - Internally unstable core materials (internal instability, internal migration).—Finer fraction may erode from these soils, leading to sinkholes (Sherard 1979). WAC Bennet Dam in British Columbia, Canada, is an example.
- Caused by foundation conditions:
- Differential settlement of soil foundation (scour).—Wister Dam in Oklahoma was a severe case of differential settlement likely causing embankment cracks that skewed across the dam aligned with soils left in the foundation resulting in concentrated leaks and scour. Details about incident are provided later in the chapter.
 - Near vertical abutments in rock (scour).—Scoured materials could be carried both into joints in the foundation and or into an unfiltered zone in the dam as was likely the case at East Branch Dam in Pennsylvania. In this case, the core was likely cracked due to a near vertical step in abutment, the core was definitely scoured and much of the core material was transported by leakage to the toe through an unfiltered rockfill drainage layer in the embankment. Broadhead Dam also in Pennsylvania was another case where it appeared embankment cracks led to scour into a gravel drain that did not successfully filter. At the contact between the dam and foundation: The contact between the embankment and a rock foundation is a key place to evaluate. There are a number of case histories of this location, a couple of which led to failure. About 6 percent of Reclamation’s dam incidents are likely to have occurred at this location.

Chapter D-6 Internal Erosion Risks for Embankments and Foundations

- Rock foundations:
 - Continuous, open joints or bedding planes (Scour) .—Scour of core materials can occur along pathways through an embankment but can also transport soils from the core into openings in bedrock such as likely occurred at the Fontenelle Dam in Wyoming, Teton Dam in Idaho, and Quail Creek Dike in Utah (see later in this chapter for details about the first two of these cases).
 - Open untreated joints beneath the shells of dams has led to internal migration and sinkholes vertically above the location of the open joints such as Churchill Falls Dykes, Canada (Sherard 1979).
 - Karst (internal migration, scour).—The apparent collapse of karst features has led to collapse of overlying foundation soils due to internal migration at Wolf Creek Dam in Kentucky. At Clearwater Dam in Missouri the collapse led to internal migration within the upstream shell and a sinkhole.
 - Soil foundation.
 - Silt placed against gravel in foundation (soil contact erosion, internal migration).—ICOLD (2015) cited a case history on the River Rhone in France.
- **Through the foundation.**—This location was responsible for approximately 70 percent of Reclamation’s dam incidents. This is the most common internal erosion failure mode for levees.
- Soil foundations:
 - Natural impervious blanket over continuous, uniform, fine to medium sands (BEP).—A.V. Watkins Dam in Utah was a case where the overlying blanket contained thin hard pan layers that formed the roof for BEP of underlying fine sands into a downstream ditch. Details of the case are provided later in this chapter. Bois Brule and Kaskaskia Island are cases of levees that breached due to BEP during the 1993 Mississippi River flood.

Chapter D-6 Internal Erosion Risks for Embankments and Foundations

- Internally unstable soil deposit (II, IM).—These cases have frequently led to internal migration as overlying non-plastic soils tend to collapse down into voids caused by the removal of fines in cases of internal instability. For a zoned embankment with an internally unstable filter, after washout of the fines occurs due to suffusion, the filter gradation may become too coarse to provide adequate particle retention.
- Desiccation cracks (scour).—Poorly treated foundation subgrades.
- Earth fissures due to subsidence (scour).—This can be caused by ground water extraction, oil extraction, or underground mining. This can also lead to defects in the embankment.
- Differential settlement of foundation soils (scour, IM).—At Mississinewa Dam in Indiana it appears that foundation soils were damaged due to scour or internal migration into underlying karst which led to localized crest settlements roughly over the features. Later investigations revealed the embankment was likely damaged as well.
- Rock foundations.
 - Soil-filled joints (scour).—Highly dependent upon geology and continuity
- Into or along a through-penetrating structure:
 - Flaw in embedded pipe (BEP).—Caldwell Outlet Works at Deer Flat Dams in Idaho was a case of backwards erosion piping of the foundation soils into cracks in the conduit (see later in this chapter for details about this case). About 5 percent of Reclamation’s dam incidents associated with conduits.
 - Along an embedded wall (scour).
 - Along an embedded pipe (scour, BEP).—There are numerous cases of levee incidents or breaches associated with poor compaction and construction details around corrugated metal gravity interior drainage pipes.
 - Out of open defect in an embedded structure (scour, BEP) .—Flow out of a pressurized conduit.

Chapter D-6 Internal Erosion Risks for Embankments and Foundations

- Into a drain.—About 11 percent of Reclamation’s dam incidents likely occurred into drains.
- Broken structural drain on soil foundation (BEP, IM).—Broken stilling basin drains at Davis Creek Dam in Nebraska likely initiated BEP beneath the conduit that resulted in internal migration as a sinkhole formed adjacent the control house (see “section D-6.9.8, Relevant Case Histories,” in this chapter for details).
- Damaged embankment toe drain (IM, BEP).—typically resulted in sinkholes (IM).

D-6.6 Loading Considerations

Internal erosion failure modes can develop in response to a loading applied to the embankment or its foundation. The loading is generally characterized as either:

- Static/normal operation (i.e., reservoir level at or above a threshold elevation that would cause initiation of internal erosion).
- Hydrologic (i.e., related to a flood or reservoir level higher than the normal operating reservoir level).
- Seismic (i.e., earthquake causes deformation and/or cracking that would cause initiation of internal erosion).

The likelihood of achieving a certain peak water level can be estimated by developing reservoir or river stage exceedance relationships based on historical operations and floods. Water levels where seepage flows/boils are observed, or a potential structural/geologic defect are loaded are potential thresholds for internal erosion and should be included in the peak flood load ranges used in the event. The loading conditions for seismic potential failure modes are discussed in “chapter D-8, Seismic Risk for Embankments.”

D-6.6.1 Dams Operated for Storage

For dams that have been nearly fully loaded, (i.e., the design normal water surface) it is typical to separate potential failure modes under normal operating (static) conditions from hydrologic and seismic-related potential failure modes. For reservoirs that serve primarily as water storage, it is not unusual that they fill nearly every year, and in such cases a value of 1.0 for this loading event is frequently assigned. Where the reservoir does not typically fill, the likelihood of achieving a high or threshold reservoir is typically based on reservoir exceedance curves. If the static evaluation of the risk at a dam includes the use of historic

Chapter D-6 Internal Erosion Risks for Embankments and Foundations

rates of initiation based on internal erosion incidents, care must be taken in the selection of the loading interval to start the evaluation of the flood loading to avoid double-counting the load. For flood loadings (which are considered to be hydrologic failure modes), an estimate of the likelihood of reaching the historical high and higher elevations must be determined from flood frequency analysis and possibly flood routings (see “chapter B-1, Hydrologic Hazard Analysis”).

D-6.6.2 Dams and Levees Operated for Flood Risk Management

For dams and levees operated primarily for flood risk management, or have significant flood storage and in any case have not been significantly loaded or are not significantly loaded very often, the loading can vary significantly from year to year. Therefore, the full range of flood loading must be considered without evaluating static loading separately. The “static” loading in this case is essentially included in the hydrologic loading evaluation. Cumulative plots of annual probability of failure, average annual life loss, and average annual economic loss associated with “normal” operating ranges or floods of interest can be used to evaluate and portray risks for various levels of loading (e.g., for reservoir levels up to conservation pool) and help identify critical load ranges that may be contributing the most risk.

For each potential failure mode, the risk team can establish load increments for evaluation. These can be used in developing a system response curve that relates the conditional probability of failure to the water level for the full range of loading. Non-linear portions of the loading or system response can unknowingly lead to results that are controlled by less well-defined portions of curves. Therefore, the water levels must be carefully selected to define the shape of the system response curve, especially at elevations where significant changes in the probabilities may occur. In general, partitioning of the flood loading should consider the following elevations:

- Elevation of the peak annual pool or stage.
- Elevation where the probability of initiation of erosion becomes non-zero (e.g., bottom of a crack, elevation of rock defect, etc.).
- Geological features which occur above a particular level in the foundation (e.g., highly permeable gravel layer).
- Elevations where there is a documented change in performance (e.g., boils, high piezometric levels, etc.)

Chapter D-6 Internal Erosion Risks for Embankments and Foundations

- Topographic features (e.g., major changes in foundation profile)
- Elevations corresponding to changes in design (e.g., top of filter, top of impervious core, or top of downstream berms)
- Record pool or stage elevation. This is an important elevation because the embankment and its foundation have been tested up to this level.
- Uncontrolled spillway crest or key elevations associated with controlled spillway operations or design overflow weir sections.
- Probable Maximum Flood (PMF) elevation
- Elevation of the embankment crest

The water levels do not have to be consistent between failure modes or with the stage-frequency curve as long as the full range of loading is covered. Typically, 3 or 4 water levels are selected, but the actual number should be adequate to define the shape of the system response curve.

D-6.7 Initiation – Erosion Starts

“Initiation” is the first event of the conceptual model of an internal erosion failure. Arguably, this is the most difficult event to evaluate and estimate and also the most important (i.e., tends to have the most potential impact on the estimated annual probability of failure).

Garner and Fannin (2010) developed a Venn diagram as shown on figure D-6-15 to illustrate that internal erosion generally initiates with the unfavorable coincidence of: (1) material susceptibility (e.g., low plasticity clay susceptible to cracking); (2) stress conditions (e.g., foundation geometry and construction practices are conducive to development of low stress zones in the embankment); and (3) hydraulic load occur (e.g., water level rises to crack and flow velocity in the crack is sufficient to initiate concentrated leak erosion).

The concept that the initiation of internal erosion is in part dependent on material properties, hydraulic conditions, and in situ stress provides a good starting point to discuss each of these factors.

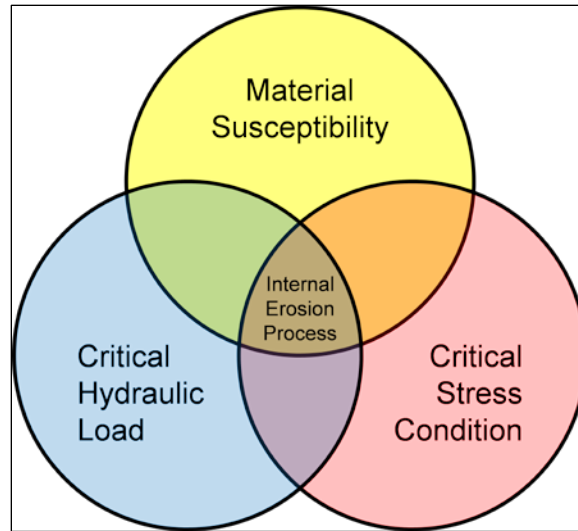

Figure D-6-15.—Factors affecting the initiation of internal erosion (adapted from Garner and Fannin 2010 and ICOLD 2015).

D-6.7.1 Effect of Material Properties on Initiation

D-6.7.1.1 Gradation, Particle Size, and Density

The actual in situ soil gradation and particle size as well as the continuity of a deposit or zone are important to all internal erosion failure modes. As particle size increases (as in coarser sands and gravels, cobbles, and boulders), it takes a higher seepage velocity (more energy) to move soil particles. It is important to recognize that laboratory gradations may not be representative of in-situ soils with larger particle sizes or soils susceptible to segregation or washout. Density of the soils plays an important role as well. The denser the soil, the harder it becomes to dislodge the soil particles and initiate erosion. Denser soil has lower permeability resulting in lower velocities of seepage, but this consideration will not apply to most, if not all, scour processes. Density and plasticity also play a role in whether materials will be cracked or contain a flaw as discussed below.

D-6.7.1.1.1 Backward Erosion Piping

Laboratory testing by Schmertmann (2000) and various researchers in The Netherlands have shown that uniform soils provide significantly less resistance to BEP than broadly graded soils, while the latter may be susceptible to internal instability or suffusion as discussed below. This laboratory testing as well as forensic investigations of levee breaches in the United States generally indicate that BEP mostly occurs in the foundation, where the eroding soil is fine to medium sand with a coefficient of uniformity (C_u) less than about 3. Example uniform gradations susceptible to BEP are illustrated on figure D-6-16.

Chapter D-6 Internal Erosion Risks for Embankments and Foundations

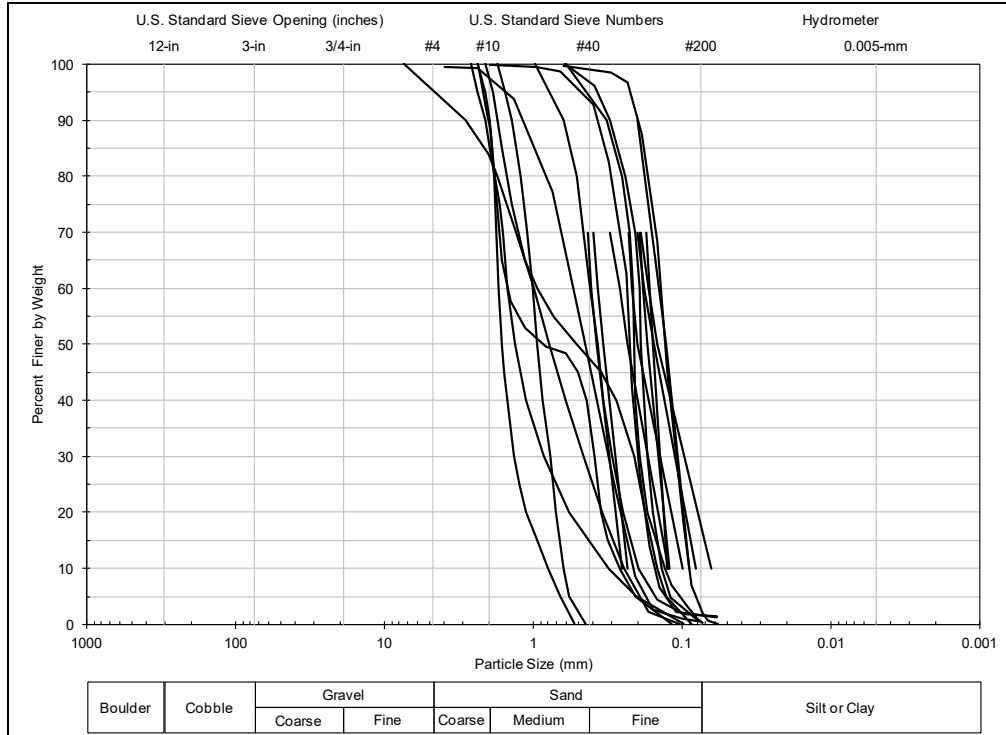

Figure D-6-16.—Soils susceptible to BEP (de Wit et al. 1981; Townsend and Shiau 1986; van Beek et al. 2008; 2009).

D-6.7.1.1.2 Suffusion

Internal instability and suffusion are a concern for broadly-graded soils (i.e., soils with wide range of particle sizes – cobbles and gravels with sands, clays, and silts) with a flat tail of fines and gap-graded soils (i.e., missing mid-sized particles). Examples of these types of soils are shown on figure D-6-17. Glacial soils can frequently fall into either of these categories.

According to Sherard (1979), soils are generally considered “internally unstable” if the coarser fraction of the material does not filter the finer fraction. Sherard obtained data from a number of embankment dams, where sinkholes appeared on the crest and slopes of widely graded embankment embankments of glacial origin, and plotted a band around these gradations, as shown on figure D-6-18. The internally unstable soil gradations usually plotted as nearly straight lines or as curves with only slight curvature within the range shown. Reclamation’s filter design standard (Reclamation 2011) also considers the slope of the gradation curve. This slope is illustrated on figure D-6-18 and is noted as “4x.” The slope of this line is approximately equal to the boundary slopes of Sherard’s band. The location of the “4x” line on the plot is unimportant. Any portion of a gradation curve that has a flatter slope than this line indicates a potentially unstable soil, whereas portions of the gradation curve steeper than the line indicate a stable soil. This technique can also be used to evaluate gap-graded soils.

Chapter D-6 Internal Erosion Risks for Embankments and Foundations

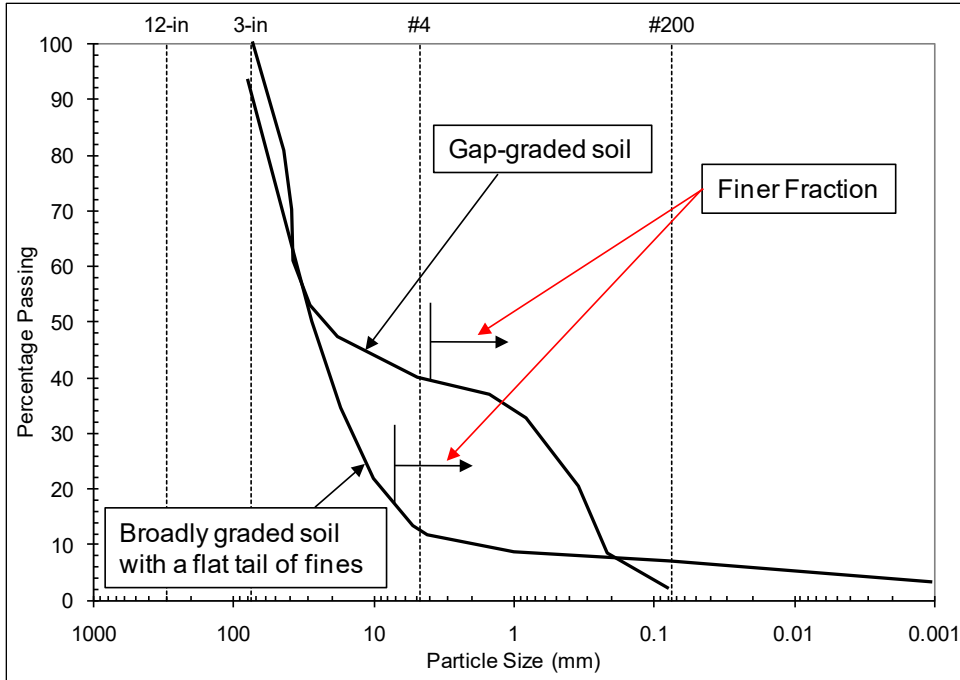

Figure D-6-17.—Potentially internally unstable soils (adapted from Wan and Fell 2004a).

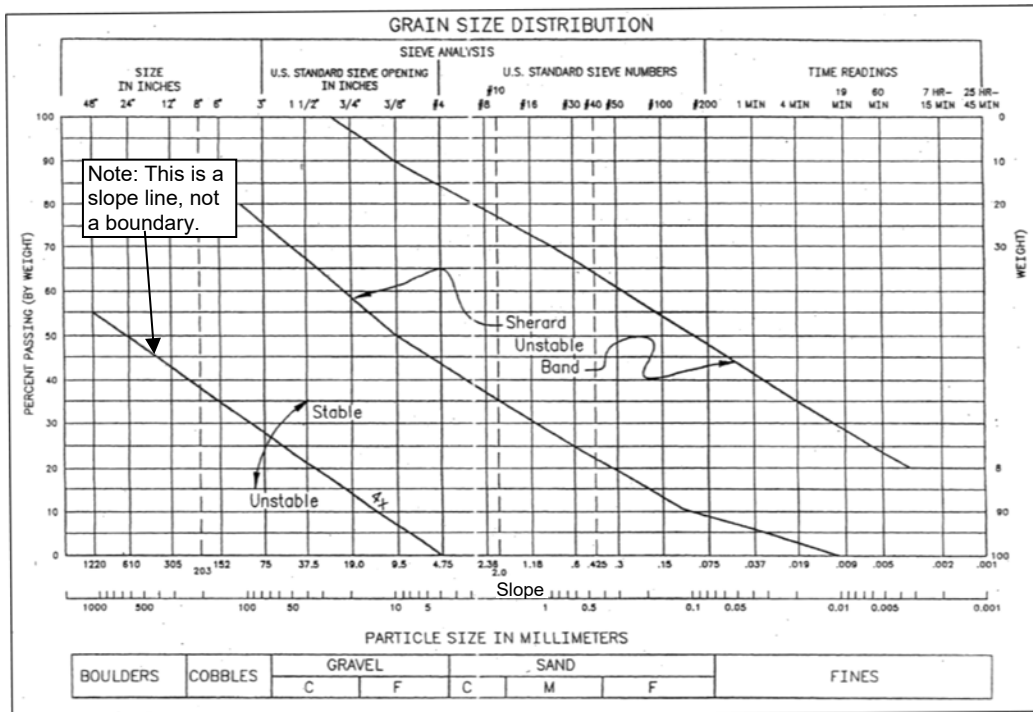

Figure D-6-18.—Potentially internally unstable soils (Sherard 1979 and Reclamation 2011).

D-6.7.1.2 Plasticity and Erodibility

Plasticity appears to be one of the most important factor affecting the potential for internal erosion to initiate. Based on an examination of Reclamation internal erosion incidents (Engemoen 2017), it is estimated that 80 percent of cases of all internal erosion at Reclamation embankments have been associated with soils of no to low plasticity ($PI < 7$). BEP is simply far more likely to occur in cohesionless (or low plasticity) soils than in cohesive or plastic soils. Fell et al. (2008) indicate that the likelihood of BEP and suffusion in cohesive soils ($PI > 7$) is essentially zero under the seepage gradients which typically occur in embankments and their foundations. Plastic soils will also be less likely to experience other internal erosion mechanisms as well. This is apparent from case histories. The likely reason is that inter-particle bonding present in non-dispersive clayey soils provides additional resistance to leakage or seepage than in silts and coarse-grained soils.

Medium to high plasticity clay fines are less susceptible to cracking, hydraulic fracturing, or wetting-induced collapse settlement. However, the effect of plasticity varies with water content and compaction, with greater cracking potential in drier and stiffer/denser soils that would behave in a more brittle manner. Plasticity also affects the susceptibility of exposed embankment surfaces, including seasonal shutdown layers and staged construction surfaces, to environmental conditions. Medium to high plasticity soils are more susceptible to desiccation cracking than low plasticity to non-plastic soils, and low plasticity silts, silty sands, and silty gravelly and silty sandy soils are more susceptible to freezing than clean gravelly and sandy soils and high plasticity clays (Fell et al. 2008).

A key consideration in the likelihood of initiation of erosion is the erodibility of the embankment core and/or foundation materials. The likelihood of erosion initiating is much higher in highly erodible soils. Sherard (1953) published an early erosion resistance classification which is still useful in evaluating the likelihood of erosion, shown in table D-6-1; the lower the number, the greater the erosion resistance. Note that plasticity and compaction moisture content plays a key role in erodibility. Table 8 of Sherard (1953) provides a more detailed examination of the soil characteristics from the case histories examined than table D-6-1 for both BEP and cracking. Due to its size, that table is not reproduced in this document. ICOLD (2015) has prepared a similar classification for resistance to concentrated leak erosion based on Fell et al. (2008), as shown in table D-6-2. “Chapter D-1, Erosion of Rock and Soil” describes the erodibility parameters including critical shear stress and erosion coefficient that are used in the prediction of erosion of soils subject to concentrated leak erosion.

Dispersive soils are not addressed in table D-6-1 but can be even more erodible. Dispersive soils are typically clays in which the clay particles can disperse or deflocculate (go into suspension) under still conditions, quite the opposite of most

Chapter D-6 Internal Erosion Risks for Embankments and Foundations

Table D-6-1.—Piping Resistance of Soils (adapted from Sherard 1953)

Greatest Piping Resistance Category (1)	1. Plastic clay, plasticity index (PI) > 15, well compacted.
	2. Plastic clay, PI > 15, poorly compacted.
Intermediate Piping Resistance Category (2)	3. Well-graded material with clay binder, $6 < PI < 15$, well compacted.
	4. Well-graded material with clay binder, $6 < PI < 15$, poorly compacted.
	5. Well-graded, cohesionless material, $PI < 6$, Well compacted.
Least Piping Resistance Category (3)	6. Well-graded, cohesionless material, $PI < 6$, poorly compacted.
	7. Very uniform, fine cohesionless sand, $PI < 6$, well compacted.
	8. Very uniform, fine, cohesionless sand, $PI < 6$, poorly compacted.

Table D-6-2.—Erosion Resistance of Soils from Concentrated Leaks (Scour) (adapted from ICOLD 2015)

1. Extremely Erodible	All dispersive soils; Sherard pinhole classes D1 and D2; or Emerson Crumb Class 1 and 2. And SM with FC < 30%
2. Highly Erodible	SM with FC > 30%, ML, SC, and CL-ML
3. Moderately Erodible	CL, CL-CH, MH, and CH with LL < 65
4. Erosion Resistant	CH with LL > 65

Note: Soil symbols are in accordance with the Unified Soil Classification System (ASTM Designation D-2487).

clays that require considerable seepage velocities to begin the erosion process. Dispersivity is related to clay mineralogy and particularly the electrochemical forces between soil particles as well as the pore water; soils having a high exchangeable sodium percentage (ESP) are more susceptible. Dispersive clays are not limited to specific types, colors, geomorphology, or climatic conditions. Marine clays located in southern States where inland seas were present are often susceptible (e.g., Mississippi, Alabama, Arkansas, Louisiana, Texas, Oklahoma, New Mexico, and Arizona). It is difficult to tell whether a clay is dispersive without specific tests. However, it is common that some erosion features are observed in natural deposits of dispersive soils. Applicable laboratory tests that provide a measure of soil dispersivity include the (Emerson) Crumb test, the Soil Conservation Service Double Hydrometer test, the (Sherard) pinhole tests, and chemical tests that evaluate ESP or sodium absorption ratio. It is frequently suggested that at least two different tests be run to check for dispersivity. Experience suggests initiation of internal erosion in dispersive clay has generally occurred on first reservoir filling or upon raising the reservoir to new levels for the first time (Sherard 1979).

D-6.7.2 Effect of Hydraulic Conditions on Initiation

D-6.7.2.1 Role of Concentrated Leakage or Seepage

Embankments and foundations are not completely impervious, and thus, virtually all dams and levees have some degree of seepage. It is not necessarily the amount of seepage that leads to internal erosion incidents; rather it tends to be whether concentrated leakage or seepage is occurring in soils that are susceptible to erosion and at sufficient velocities to detach and transport particles. In other words, the initiation of erosion typically requires a particular pathway that allows a concentrated flow within a generally limited or localized area or feature within an embankment or its foundation (e.g., cracks in the embankment, bedrock joints, open rock defects, erodible sand beneath a roof-forming material, etc.). General seepage models that portray seepage through porous media represented by large zones or layers feature an idealized situation that is generally unlikely to accurately portray the potential for internal erosion in most cases. Instead, it is the “weak link” or anomaly in an embankment or foundation where a concentrated flow is likely to occur and result in an incident. Such weak links or reasons for concentrated flows typically include the types of defects previously discussed, as well as naturally occurring pervious layers that are susceptible to erosion. Practitioners typically use available laboratory testing, research, and empirical evidence to probabilistically estimate internal erosion potential in risk analyses. References to consider in aiding these determinations are provided in the appendices.

D-6.7.2.2 Gradients

It is important to recognize that there are two types of gradients associated with seepage through porous soils and internal erosion: vertical and horizontal gradients. Vertical (upward) gradients are considerations in the potential for heave, uplift or blowout, and sand boils and can lead to unfiltered exits or potential initiating conditions for an internal erosion mechanism. Horizontal (internal) gradients through an embankment or its foundation play a key role in whether internal erosion will initiate and progress.

D-6.7.2.2.1 Vertical Gradients

Traditional soil mechanics or seepage discussions on critical vertical exit gradients (e.g., by Terzaghi et al. 1996) have typically only presented examples using sand foundations. The term “heave” was used to describe the condition when the saturated sand specimen, subjected to upward seepage flow in the laboratory, suddenly decreases in density and increases in permeability. This limit-state condition occurs when the seepage pressure on a plane in the specimen equals the weight of the specimen, and the effective pressure becomes zero. The traditional equation can be rearranged to solve for the upward hydraulic gradient

Chapter D-6 Internal Erosion Risks for Embankments and Foundations

(or critical vertical gradient) which is then further reduced to the more recognizable form in practice as the ratio of the buoyant unit weight of the soil (γ_b) to the unit weight of water (γ_w):

$$i_{cr} = \gamma_b / \gamma_w \quad \text{Equation D-6-1}$$

This simplified relationship for the critical vertical exit gradient can also be expressed as the condition when the pore water pressure equals the submerged unit weight of the soil, and thus the effective stress is zero. At the critical vertical gradient in cohesionless foundations, a “quick” condition exists in the sand, and the foundation materials may “heave” or “boil” as shown on figure D-6-19. Sand boils are an indicator of locations where the critical vertical exit gradient is close to or may have been reached.

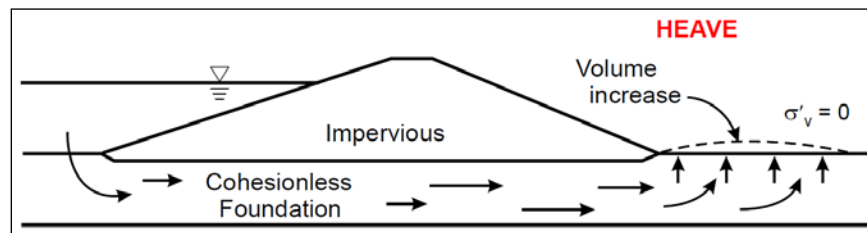

Figure D-6-19.—Heave at the toe of an embankment (Pabst et al. 2013).

In the case of cohesionless foundations with no confining layer and vertical (upward) flow at the toe, vertical exit gradients (i_e) can be estimated using seepage analyses or piezometric data and then compared to the critical vertical gradient. Estimated vertical exit gradients less than the critical vertical gradient provide an indication that they may not be sufficient to create heave/boiling conditions at a seepage exit. Depending on the state of knowledge about given site conditions, there can be significant uncertainty with the estimated values of gradients. It should be noted that Darcy’s flow equation is only valid until the critical gradient is reached. At the critical gradient, the sudden rearrangement of particles results in a sudden increase in discharge at the same gradient indicating the flow is no longer proportional to the gradient and permeability is no longer a constant. It is possible that sand boils may form, but significant particle transport may not occur due to other conditions, such as inability to hold a roof, heterogeneity of actual soil deposits, or insufficient horizontal gradients over a long enough time to fully develop an internal erosion mechanism.

A “blanket-aquifer” foundation consists of a low permeability, confining layer (such as clay) overlying a pervious layer (such as sand). If the pervious layer is not cut off upstream, seepage pressures in the pervious layer at the base of the confining layer may exceed the overburden pressure of the confining layer

Chapter D-6 Internal Erosion Risks for Embankments and Foundations

(i.e., soil blanket) at the downstream or landside toe of an embankment, and uplift (or “blowout”) of the confining layer may occur as shown on figure D-6-20. This is a primary concern for levees, and the term “heave” has also been used to describe uplift/blowout of the soil blanket by United States Army Corps of Engineers (USACE) and others in the literature. When soil blankets are ruptured, sand from an underlying aquifer will often be forced up through the confining layer, producing sand boils. A quick/boiling condition that often forms in cohesionless material may not exist around the sand boil, but “spongy” ground conditions are often noted and can be seen and felt when walking on a ruptured or an uplifted soil blanket.

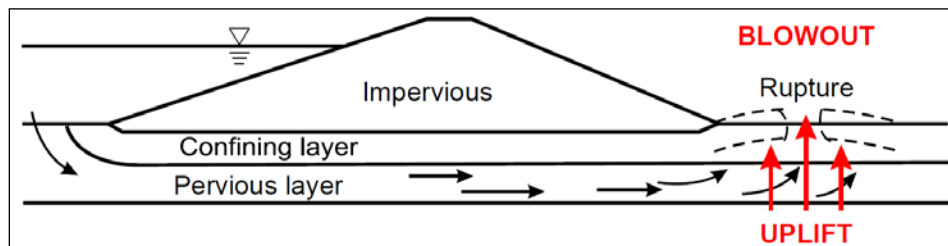

Figure D-6-20.—Uplift and/or blowout at the toe of an embankment (Pabst et al. 2013).

The limit-state condition for uplift of the confining layer is reached when the uplift pressure at the base of the confining layer equals the weight of the confining layer (at the time the corresponding uplift pressure is applied). If the uplift pressure in the field exceeds the weight of the confining layer at any time, uplift is likely to initiate and result in significant changes in the seepage regime. If uplift or blowout does occur, a potential unfiltered exit location is provided where internal erosion may initiate. As uplift occurs, a new seepage exit can form beneath the confining layer where hidden deterioration can occur from concentrated seepage if the horizontal gradients are high enough. With blowout, the confining layer is ruptured providing an unfiltered exit to the ground surface. The specific location of a rupture may be the result of a defect and/or the location of the maximum uplift pressure. If hidden deterioration was occurring before the blanket ruptured, these locations may be coincident. As previously mentioned, significant particle transport may not occur due to other conditions related to material erodibility, roof formation, and insufficient horizontal gradients to develop an internal erosion mechanism.

The assumptions for seepage conditions, tailwater conditions, degree of saturation, and density of the confining layer must be carefully considered in the evaluation of the limit state for uplift of the confining layer. Uplift can also initiate in partially saturated confining layers, especially for light weight soils (peat or organic soils) or cohesive soils in cases of drought.

Chapter D-6 Internal Erosion Risks for Embankments and Foundations

For blanket-aquifer foundations, two methods have been used to evaluate uplift and/or blowout of the confining layer. One method involves simply comparing the uplift pressure acting at the base with the weight of the fine-grained soil blanket at the time the corresponding uplift pressure is applied. The other method is the critical gradient approach which is commonly used for cohesionless foundations with no confining layer and vertical (upward) flow at the toe. Both approaches are applicable to some embankments, for example embankments which have blankets that vary significantly in key properties such as erosion resistance (ML versus CH) or blankets that are discontinuous due to an old ox bow. When in doubt, both can be used to inform the risk team. The critical gradient method is used primarily for levees and involves comparing the actual gradient across the landside soil blanket (confining layer) to the maximum allowable gradient. An “underseepage factor of safety” is calculated assuming steady state-seepage conditions, which reduces to the same form as the critical vertical gradient approach mentioned above. Text books and literature are not always clear in defining what approach is preferred, or even in distinguishing between the two approaches. When conducting a risk analysis, the team should consider the most appropriate methodology for their site-specific conditions to help them better understand the potential failure mode and its likelihood to develop. The potential for heave, uplift, and/or blowout in the field can be greatly influenced by geologic details, the details of man-made features, climatic conditions, as well as biological and chemical processes such as excavation by rodents, plugging of seepage exits by bio-fouling, or mineral deposition. Risk teams should be aware and consider these key factors and whether or not they are included in analyses.

D-6.7.2.2.2 Horizontal Gradients

Horizontal (or nearly so) gradients are internal gradients along a seepage or leakage pathway through an embankment and/or foundation. They affect the likelihood that internal erosion can occur by such means as concentrated leak erosion, backwards erosion piping, or suffusion. There is a fundamental difference between upward gradients and horizontal gradients. Upward gradients are resisted by gravity and relate to the potential for heave or uplift and the possible initiation of internal erosion. However, gravity is not a resisting force for a horizontal seepage exit such as in a ditch at the toe of the embankment, and little to no horizontal gradient is required for initiation of internal erosion.

A typical “critical” vertical (upward) exit gradient in cohesionless soils is often thought to be around 1.0 for a specific gravity of 2.7 (where heave is concerned) and higher for cohesive soils not subject to uplift. However, the magnitude of horizontal gradient that has led to internal erosion is much lower. For example, the horizontal gradient at Reclamation’s A.V. Watkins Dam incident was calculated to be 0.06, and the horizontal gradient at USACE’s Wister Dam, which suffered concentrated leak erosion, was reported to be 0.02 (but contained some dispersive clays). Horizontal gradients as low as 0.02 were estimated for levees

Chapter D-6 Internal Erosion Risks for Embankments and Foundations

along the Mississippi River in 1937, 1947, and 1950, as shown on figure D-6-21. Evaluation methods for horizontal gradients are discussed in “appendix D-6-E, Critical Gradients for Evaluation of Backward Erosion Piping.”

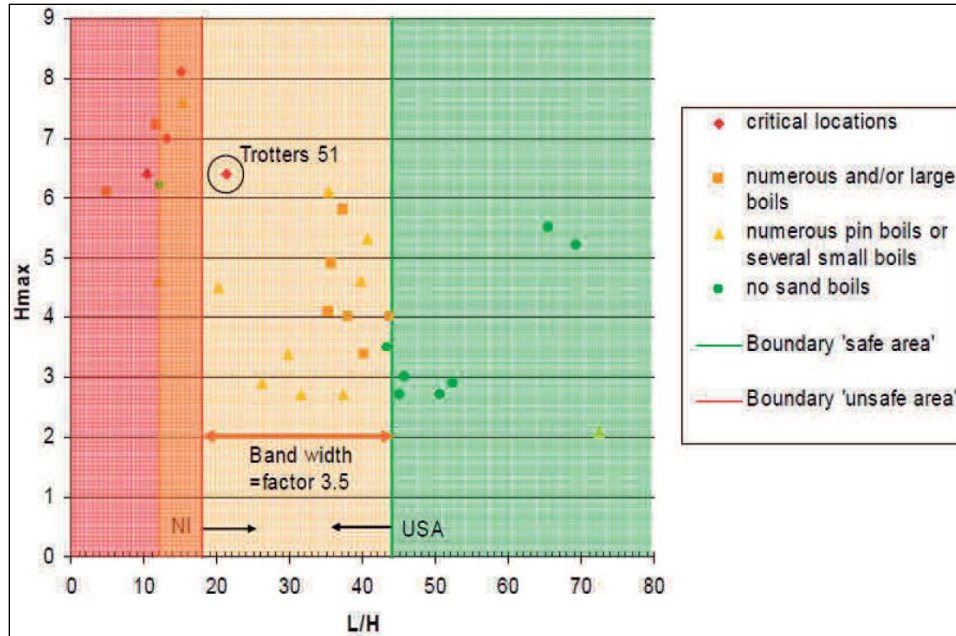

Figure D-6-21.—Critical sand boil locations along Mississippi River levees (adapted from Ammerlaan 2007).

Unlike vertical exit gradients in sands, there is no widely accepted formula with which to evaluate when horizontal gradients might lead to internal erosion. In large part, this is due to no simple test to capture the physics that control whether or not it will occur. Unlike critical gradient piping by heave in cohesionless soils, no single laboratory test can be performed to determine the “gradient” at which erosion initiates and/or progresses. There is a great deal of uncertainty and variability inherent in lengthy seepage flow paths through embankment or foundation soils. These uncertainties include:

- Internal gradients are likely quite different at various places along the seepage pathway since natural, or even engineered, soils can be highly variable. The seepage path is undoubtedly not a straight line and likely meanders considerably, with seepage flows experiencing different amounts of head loss along the way.
- It is extremely unlikely that sufficient piezometers would be located in a number of critical locations along a seepage pathway in or beneath an embankment to accurately measure the piezometric pressures at key points in the critical (weak link) flow path.

Chapter D-6 Internal Erosion Risks for Embankments and Foundations

- Furthermore, it is exceedingly difficult to accurately assess how the soils along an entire seepage pathway will respond to seepage gradients. Laboratory tests can provide insights into how a relatively small segment of representative soil will behave under various hydraulic gradients, and these studies suggest that key factors like soil plasticity and grain-size are important parameters in determining the potential for internal erosion. In actual field conditions, both soils and gradients are expected to vary in most instances.

Some studies indicate seepage forces on sand grains due to upward flow into the head of a developing pipe is a key reason that the critical horizontal gradient can be significantly lower than the critical vertical gradient. This is consideration is more significant when higher permeability layer exists beneath the eroding layer that helps concentrate flow into the developing pipe.

D-6.7.2.2.3 Concentrated Leak Erosion

Horizontal gradients can be used to estimate hydraulic shears stress for concentrated leak erosion, as described in “appendix D-6-C, “Concentrated Leak Erosion.” For simplified crack or pipe geometries, the hydraulic gradient in this case is the hydraulic head difference divided by the length of the pipe or crack over which the hydraulic head difference occurs. As demonstrated by tests such as the Hole Erosion Test (HET) and the Jet Erosion Test (JET), cohesive soils are able to withstand much higher gradients than cohesionless soils before erosion initiates. However, this is not the case if the cohesive soils are dispersive. Case histories demonstrate embankments comprised of dispersive soils can erode quickly by internal erosion. As reported in Fell et al. (2008), highly erodible soils such as silts, silty sands, or dispersive clays may be likely to erode at a crack width of 0.25 to 0.5-inch under a hydraulic gradient as low as 0.1, and at widths as small as 1 or 2 mm under hydraulic gradients of 0.5 or more. Clays may not be likely to erode until cracks reach 1 or 2 inches in width and hydraulic gradients approach 0.5 or more. However, cracks in clays may swell shut upon wetting.

D-6.7.2.3 Velocity

D-6.7.2.3.1 Soil Contact Erosion and Suffusion.—Seepage velocity can be used to as a measure of the hydraulic conditions for initiation of internal erosion. For soil contact erosion, the Darcy velocity is estimated and compared to a critical value to help assess the likelihood of initiation (see “appendix D-6-D, Soil Contact Erosion,” for more details). In addition to hydraulic gradient and hydraulic shear stress methods, pore velocity can be used to assess the hydraulic conditions for suffusion. These methods are referenced in “appendix D-6-F, Critical Gradients for Evaluation of Backward Erosion Piping.”

D-6.7.3 Effect of Stress Conditions and Presence of “Flaws or Defects” on Initiation

D-6.7.3.1 Low Stress Zones and “Arching”

The formation of low stress zones, or even tension zones, in an embankment is known to have led to many failures and incidents involving internal erosion. The zones can occur in areas of severe differential settlement. Foundation anomalies and conduits in narrow trenches have led to numerous instances of cracking and potentially hydraulic fracturing. In many cases, these low stress zones essentially lead to flaws or defects.

D-6.7.3.2 Conditions Associated with Initiation of Internal Erosion

This abbreviated list provides insights into what in-situ conditions increase the likelihood of an internal erosion process initiating. “Appendix D-6-G, Detailed List of Conditions which Increase the Likelihood of Initiation of an Internal Erosion Process,” contains a more detailed list.

Leads to increased likelihood of scour:

- Through the embankment
 - Cracking from differential settlement of embankment materials due to shape of abutment or foundation or details of embankment cross section
 - Cracking of embankment due to differential settlement in foundation soils
 - Defects due to construction
 - Cracking due to exposure (desiccation or freeze-thaw action)
 - Animal burrows and vegetation
 - Cracking due to an earthquake
- Through the foundation
 - Untreated soil-filled joints
 - Silt and fine sand deposits against open-work gravels

Chapter D-6 Internal Erosion Risks for Embankments and Foundations

- Earth fissures due to subsidence caused by ground water extraction, oil extraction, or underground mining (can also lead to scour through the embankment)
- From the embankment into the foundation or along the embankment-foundation contact
 - Open joints, seams, faults, shears, bedding planes, solution features, or other discontinuities at contact with rock foundation.
 - Silt embankment constructed directly upon openwork gravel.
- Along structures:
 - Cracking of embankment associated with conduits
 - Poor compaction due to shape of structure

Leads to increased likelihood of internal migration:

- Through or in the embankment
 - Broadly graded core placed in contact with coarse grained fill (typically happens along a steep core/shell contact)
- Through the foundation
 - Fine-grained soils over coarse grained open work soils (such as reservoir sediment over glacial outwash gravels)
- From the embankment into the foundation or along the embankment-foundation contact
 - Embankment soils in contact with untreated open joints, seams, etc. in foundation rock
 - Non-cohesive or low PI embankment fill founded upon against openwork gravels.
- Into structures
 - Damaged conduit

Chapter D-6 Internal Erosion Risks for Embankments and Foundations

- Into drains
 - Broken drain pipes or inadequately designed drain system

Leads to increased likelihood of backwards erosion piping:

- Through Embankment
 - Severe filter incompatibility at core contact with shell
 - Animal burrows
 - Scour of impervious layer on riverside slope of sand levee
- Through the foundation
 - Continuous uniform fine to medium sand underlying a roof-holding material
 - Thin natural impervious blanket overlying fine sands connected to river or reservoir
 - Penetrations or defects in the blanket
 - Riverside scour of the blanket
- From the embankment into the foundation
 - Core material placed directly against open-work gravels in bottom of downstream side of cutoff trench
- Along or into structures
 - Poor compaction around a structure
 - Damaged conduit surrounded with non-cohesive embankment or founded upon fine sands
- Into drains
 - Broken drain pipes or inadequately designed drain system

Leads to increased likelihood of internal instability:

- Through the embankment
 - Non-plastic broadly graded thin core against coarse shell and defects due to construction (segregation)
- Through the foundation
 - Broadly graded and gap-graded soil deposits such as some glacial deposits

D-6.7.3.3 Influence of Stress Conditions on Internal Instability

As described earlier, suffusion and suffosion deal with finer particles being washed out by seepage flows through a broadly graded or gap-graded, internally unstable soil. Stress conditions play a role in this process, specifically relating to whether the space between coarse particles in the soil is “over-filled” or “under-filled.” When the coarser-grained portion of an internally unstable soil are essentially in point-to-point contact, the space between coarse particles can be thought of being under-filled, and the stresses are being carried by those point-to-point contacts of the coarse particles. Thus, the finer matrix material feels little to no stress and can consequently be washed out by seepage flows. However, when the larger particle sizes are essentially floating in the finer matrix material, there is no load carried by a coarser skeleton. Thus, all particles generally experience the same stress. In this scenario, the stress conditions upon all soil grains would require a much higher seepage velocity to move the materials. This is why suffusion (or the erosion of finer soils within an internally unstable soil with point-to-point contacts of the coarser grains) is much more likely to occur than suffosion (which features the coarser grains floating in finer matrix material) under the gradients typically present in embankment dams and levees and their foundations.

D-6.7.4 Approach to Estimating the Probability that Internal Erosion Will Initiate

Given an open or unfiltered exit exists, in most cases the key event in the event tree generally used to estimate the probability of an internal erosion failure is the probability that internal erosion will initiate. Initiation is typically judged to have a relatively low probability of occurring; is based on a number of variables including presence of a concentrated seepage path (flaw), length of the seepage path, hydraulic “gradients,” and soil erodibility; and is thus difficult to estimate.

Developing the probability of initiation is typically completed using either an empirical approach or using analytical methods and application of researchers’

Chapter D-6 Internal Erosion Risks for Embankments and Foundations

findings on the potential for various soils to erode under various conditions. Neither approach should be considered more “right” as both approaches have merits. Furthermore, there may be situations when either (or both) approach might be more appropriate, and risk teams should not feel constrained to a particular approach. Regardless of the approach, the best practice is to utilize a process of evaluating all information and existing conditions at a site to flesh out potential failure modes and utilize expert elicitation to estimate the likelihood that the internal erosion process will initiate based upon the totality and strength of the evidence.

D-6.7.4.1 Empirical Approaches

Empirical approaches are based on the evaluation of internal erosion incidents or failures. The fundamental reason for an empirical approach is the difficulties and numerous uncertainties associated with applying laboratory findings and gradient assumptions to the spatially vast and variable embankment/foundation system typically being evaluated.

The statistics of historical failures and incidents can provide some insight when estimating the likelihood of initiation of internal erosion. However, such rates should be used with caution based on the general method in which they were developed, and the inventory of dams and levees used to develop the rates. Whenever historical rates are provided, they may be more representative of the product of several probabilities on the internal erosion event tree. The rates must be carefully considered based on site-specific information. Seepage from the downstream or landside slope (from visual observation, measurement, or other non-invasive methods), measured high pore pressures, settlement, deformation, and cracking are possible indicators of a flaw or defect in the embankment. Similarly, seepage at the downstream or landside toe is a possible indicator of a flaw or defect in the foundation. The influence of observations on the probability of a flaw should take into account the mechanism causing the flaw, the available data, and the relative importance of the observations.

One empirical approach was developed by Fell et al. (2004) based on records of dam incidents (Foster et al. 1998, 2000). The study provided an estimated probability of initiation of erosion for the categories of internal erosion through the embankment, associated with conduit through embankment, through foundations in soil or erodible rock and from the embankment into soil or rock foundation. Initiation estimates for first filling, reservoir above historic high and normal operation conditions were reported.

A second empirical approach was developed by Reclamation (Engemoen and Redlinger 2009, Engemoen 2011 and 2017) based solely on the incidents in the Reclamation inventory. In general, Reclamation embankments were constructed

Chapter D-6 Internal Erosion Risks for Embankments and Foundations

with wide cores (long seepage path) often flanked by shells of sands/gravels/cobbles (providing some filtering capability) and good compaction techniques. “appendix D-6-B, Historical Frequencies,” provided additional details on the use of Reclamation’s historical frequencies.

D-6.7.4.2 Analytical Approaches

A number of methods, tests, and tools are available to assist in evaluating the probability of initiation of internal erosion. These in combination with observations and the experience of the risk team provide the evidence against which the probability estimates are made. The risk team discusses these and other factors that were identified and decides which should receive the most weight.

Details of some of the analytical methods and tests which the team would consider as a “more likely” or “less likely” factor during an elicitation for the probability of a flaw existing or probability of initiation are provided in the following appendices:

- “Appendix D-6-C, Concentrated Leak Erosion”
- “Appendix D-6-D, Soil Contact Erosion”
- “Appendix D-6-E, Critical Gradients for Evaluation of Backward Erosion Piping”
- “Appendix D-6-F, Internal Instability (Suffusion)”
- “Appendix D-6-G, Detailed List of Conditions which Increase the Likelihood of Initiation of an Internal Erosion Process”

D-6.8 Continuation

Erosion once initiated will continue unless the eroding forces are reduced or the passage of the eroded particles is impeded. Evaluation of this phase of internal erosion relies primarily on examining the filter compatibility of adjacent zones and layers in an embankment and foundation. In modern embankments, filters are used to prevent the migration of fines between various zones of the embankment or its foundation and to safely protect against leakage through cracks should they occur. Existing embankments without modern filters depend on the filter compatibility of core and transition/shell materials (if present), as well as the compatibility at the core/foundation contact.

Chapter D-6 Internal Erosion Risks for Embankments and Foundations

In essence, continuation is the phase of internal erosion where the relationship of the particle-size distribution between the base (core) material and the filters or adjacent materials controls if erosion will continue. The methodology to evaluate the probability of continuation of internal erosion will vary depending on the seepage exit. Generally, three exit conditions are considered: (1) open exit; (2) filtered/unfiltered exit; or (3) constricted (non-erodible) exit. “Chapter 5, Protective Filters,” of Reclamation’s Design Standards No. 13 (Reclamation 2011) provides guidance for design and construction of soil filters, drains, and zoning of embankment dams that is useful for consideration in risk assessments of existing dams. Modern filters and drains defend against cracks and assure significant head loss occurs at the boundary if it already has not occurred because of cracks. For a filter designed used current criteria and constructed using quality materials and good construction oversight and documentation, the probability that an unfiltered exit exists would typically be very low.

D-6.8.1 Continuity

An important point about continuation is whether the unfiltered exit is truly continuous. Zones in shell materials and layers of alluvial materials that act as unfiltered exits (i.e., don’t satisfy filter compatibility) need to be continuous to an open face or extensive void space need to exist in coarse soils or bedrock for eroded fines to be deposited into.

D-6.8.2 Open Exit

If there is a free or open face, then there is no potential for filtering action due to an unfiltered exit, and the probability of continuing erosion (CE) is virtually certain (i.e., $P_{CE} \approx 0.999$). Open exits can also be the result from common-cause cracking in the filter or transition materials.

D-6.8.3 Filtered/Unfiltered Exit

Some zones may be designated as “filters” but may not satisfy the current definition of a filter. Conversely, there may be material that does not meet filter criteria but can be considered an “opportunistic filter.” The evaluation of filter compatibility between the base soil (core) and the filter or adjacent materials requires representative particle-size distribution data. When there are a greater number of gradations, the reliability of the filter compatibility assessment is improved. If the gradations are plotted on the same sheet, the normal range or gradation band can be observed for both the base soil and the filter, along with any outlier gradations. In soils containing coarse particles (gravel, cobbles, or boulders), it is important to realize they frequently do not show up in gradations. In zoned embankments, multiple filters or zones often provide transition from the finer to coarser materials. Each filter zone must be filter-compatible with the preceding zone if seepage across the boundary occurs. Therefore, the filter

Chapter D-6 Internal Erosion Risks for Embankments and Foundations

compatibility evaluation may be a multi-step process, depending on the embankment zoning. If a perforated pipe is installed in drain rock to transmit accumulated water, the compatibility with the perforations in the drain pipe must be evaluated. The following steps should be followed when assessing the likelihood of continuation of internal erosion for filtered exits:

- Gather the available information on particle-size distributions of the core or foundation and the filter or transition materials. This may include data from design-phase borrow area investigations, construction control testing, and post-construction testing on samples from the dam or its foundation. If only a few samples are available for each zone and only from borrow sources, care must be taken in drawing conclusions from the data to evaluate filter compatibility. Consider reviewing the borrow source and placement information. It may be that different portions of the embankment were placed using different borrow areas or zones within a borrow area. Therefore, some areas may have predominantly finer core material (or coarser adjacent material) and these areas should be evaluated using information specific to those areas and not the average conditions. A check if scalping was done in the field using a grizzly (i.e., screen) can be important.
- Plot the particle-size distributions for the base soil and filter materials. If the base soil contains gravel (i.e., materials larger than a No. 4 sieve), then re-grade the base soil if any of the following conditions apply: the base soil contains greater than 15 percent fines; the base soil is gap-graded; or the base soil is broadly graded ($C_u \geq 6$ and C_z between 1 and 3). If none of these conditions apply, re-grading is not required. Regrading is performed to correct for potential internal instability and a large $D_{85}B$ that could result in too large of a $D_{15}F$ size to provide adequate filtering. Reclamation (2011) provides an example of re-grading calculations.
- Consider whether the filter materials are susceptible to cracking based on fines content, cementation, or the presence of plastic fines. If the filter materials are susceptible to cracking or subject to deformations that could cause cracking, then assume there is questionable potential for filtering action due to an unfiltered exit, and there is some probability (perhaps high) of CE (estimated by team judgment).
- Consider whether the filter materials are susceptible to segregation during storing, hauling, dumping, spreading, and compacting, and if the segregated layer is continuous. If a continuous segregated layer is likely, then estimate the gradation after segregation.

Chapter D-6 Internal Erosion Risks for Embankments and Foundations

- Consider whether the filter materials are susceptible to internal instability as described in “appendix D-6-F, Internal Instability (Suffusion).” If internal instability is likely, then estimate the gradation after washout of the erodible soil fraction.
- Assess if the filter materials will prevent continuation of internal erosion using modern filter design criteria. For filter materials which are coarser than required by modern filter design criteria, the Foster and Fell (1999, 2001) method may be used because it allows assessment of filters which are too coarse to satisfy modern no erosion (NE) design criteria. The NE criteria must always be used for the design of a new filter. The other criteria are only used to evaluate existing dams.
- Check for blowout in cases where there is limited depth of cover over the filter material, comparing the seepage head at the downstream face of the core to the weight of soil cover (see “section D-6.7.2.2.1, Vertical Gradients”). In addition, check for possible slope instability assuming appropriate pore pressures.

Further details on these factors are provided in “appendix D-6-H, Continuation.”

D-6.8.4 Constricted (Non-Erodible) Exit

For erosion to continue, the open joint, defect, or crack in conduits, walls, or rock foundations needs to be sufficiently open to allow the surrounding soil particles to pass through it. The effective opening size of such defects can be used to assess whether such features will allow internal erosion to continue. Poorly designed or inadequately filtered underdrains, toe drains, relief wells, or weep holes into which embankment or foundation materials can be eroded should be evaluated using similar “opening size” considerations, where applicable.

There are no commonly adopted criteria for assessing the likelihood of continuation for this scenario, although some have used filter design criteria for perforation size for drain pipes. For example, in order to prevent erosion into a drain opening, the maximum pipe perforation dimension when designing drain pipes should be no larger than the finer side of the D_{50E} of the surrounding envelope material. Since this criteria is used for design and could be assumed to represent NE limits, it is likely conservative unless the particles are flat.

Based on the results of filter tests on uniform base soils, Sherard et al. (1984) concluded that uniform filters act similar to laboratory sieves, with an opening sieve size approximately equal to $D_{15F}/9$. In a later series of tests (Sherard 1985a), materials passing through the filters were caught and gradations of the

Chapter D-6 Internal Erosion Risks for Embankments and Foundations

material showed that approximately 97 to 99 percent of the particles were finer than $D_{15F/9}$. Foster and Fell (1999) obtained similar results. Based on these findings, Fell et al. (2008) suggested the following criterion for CE:

$$JOS_{CE} \geq D_{95E} \quad \text{Equation D-6-2}$$

where JOS_{CE} = the opening size of the defect that would allow CE of the surrounding soil; and D_{95E} = particle size adjacent to the open defect (i.e., envelope material) for which 95 percent by weight is finer after re-grading. This criterion assumes that the Foster and Fell (1999, 2001) CE criteria apply to erosion into an open joint, defect, or crack in conduits, walls, toe drains, or rock foundations, and that the crack width is equivalent to the filter opening size of the voids between the particles in a filter.

Again, it's important to remember that constrictions that are retaining soils and preventing erosion need to be continuous to some exit point. For example, bedrock joints/fractures need to be continuous to an open face and not covered by alluvium. In some rare cases where extensive void spaces may exist in coarse soils or bedrock, an open exit may not be needed, but sufficient "storage space" for eroded fines must be available. It is also important to consider the flow direction and likelihood of flow reversal.

D-6.9 Progression

Progression is the process of developing and enlarging an erosion pathway through the embankment core or foundation. The progression phase can be subdivided into three separate processes for concentrated leak erosion (scour) and backward erosion piping. These processes include: 1) formation of a continuous stable roof and/or sidewalls through the core; 2) the possibility that flows are limited by a constriction or an upstream zone or structure; and 3) the potential for an upstream zone to provide self-healing. These three considerations are commonly used, but other factors may also need to be considered for the progression phase in some cases. The progression phase includes all steps after continuation and prior to breach with the exception of intervention.

Enlargement of the erosion pathway may occur in either an upstream or downstream direction. For internal erosion mechanisms that do not necessarily require formation of a pipe that connects to the reservoir (i.e., stoping or internal migration), then the progression phase as defined here would likely be different. Currently there is no uniform practice for evaluation of progression for these other internal erosion processes, although they need to be included in specific event trees. For example, a standard progression event description could be modified to include "the probability that a large sinkhole forms in a critical area allowing progression to continue."

D-6.9.1 Progression – Continuous Stable Roof and/or Sidewalls

Formation of a continuous roof through the core or foundation is dependent on the soil conditions or presence of structures above the potentially erodible soils. Therefore, conduits, spillways, walls, and other concrete structures can form a roof along an identified potential internal erosion pathway. Interbeds of “hardpan,” caliche, or other slightly cemented materials also constitute potential roofs for underlying soils that are not capable of supporting a roof by themselves. Absent these conditions, the capability of the soil to support a roof is dependent mainly on the properties of the soil above those being eroded.

Fell et al. (2008) summarized work by Foster (1999) and Foster and Fell (1999) that evaluated case histories and found that the two most important factors for roof formation are the fines content and whether or not the soil is saturated. Soils with fines contents greater than about 15 percent were found to be likely to hold a roof regardless of the plasticity (whether non-plastic or plastic). Other influential factors include the degree of compaction (loose soil less likely to support a roof) and reservoir operation (cyclic reservoir levels were more likely to cause collapse than constant levels). Research by Park (2003)² showed that sandy gravel with 5 to 15 percent non-plastic fines collapsed quickly when saturated. Park also found that sandy gravel with 5 percent cohesive fines collapsed after some time, but very slowly with 15 percent cohesive fines. Based on these studies, table D-6-3 adapted from Fell et al. (2008), provides guidance on the likelihood a soil will be able to support a roof, absent overlying harder materials.

For concentrated leak erosion that occurs high in the embankment (e.g., cracks in the crest or a gap adjacent to a spillway wall), a roof is not necessarily a requirement for the process to progress. It is possible that the sidewalls could collapse and prevent further progression rather than collapse of a roof material. If the primary internal erosion mechanism is internal migration (stoping) without formation of a roof, then this event can be eliminated.

The presence of a structure or hard layer and soil properties are primary factors to consider in roof formation. Some other factors include soil variability along the seepage path, the length of the seepage path, and stress arching.

The probabilities should not be used directly in a risk analysis, but rather used to help develop a list of more likely and less likely factors during an elicitation of probability estimates.

²Park’s research was related to cracking in filters. Some of the test results were considered applicable to the potential for roof formation of soils.

Chapter D-6 Internal Erosion Risks for Embankments and Foundations

Table D-6-3.—Probability of Holding a Roof (adapted from Fell et al. 2008)

USCS Soil Classification	Fines Content, FC (percent)	Plasticity of Fines	Moisture Condition	Probability of Holding a Roof (P_{PR})
Clays, sandy clays (CL, CH, CL-CH)	$FC \geq 50$	Plastic	Moist or Saturated	0.9+
Silts (ML, MH)	$FC \geq 50$	Plastic or Non-Plastic	Moist or Saturated	0.9+
Clayey sands, gravelly clays (SC, GC)	$15 \leq FC < 50$	Plastic	Moist or Saturated	0.9+
Silty sands, silty gravels, silty sandy gravel (SM, GM)	$15 \leq FC < 50$	Non-Plastic	Moist Saturated	0.7 to 0.9+ 0.5 to 0.9+
Granular soils with some cohesive fines (SP-SC, SW-SC, GP-GC, GW-GC)	$5 \leq FC < 15$	Plastic	Moist Saturated	0.5 to 0.9+ 0.2 to 0.5
Granular soils with some non-plastic fines (SP-SM, SW-SM, GP-GM, GW-GM)	$5 \leq FC < 15$	Non-Plastic	Moist Saturated	0.05 to 0.1 0.02 to 0.05
Granular soils (SP, SW, GP, GW)	$FC < 5$	Plastic	Moist or Saturated	0.001 to 0.01
		Non-Plastic	Moist or Saturated	0.0001

Notes:

¹ Lower range of probabilities is for poorly compacted materials (i.e., not rolled), and upper bound is for well compacted materials.

² Cemented materials give higher probabilities than indicated in the table. If the soils are cemented, use the category that best describes the particular situation.

D-6.9.2 Progression – Constriction or Upstream Zone Fails to Limit Flows

There are some cases where internal erosion can progress to the point where the dam core or foundation is eroded through, but a flow constriction at some point along the path, an upstream zone, or facing element limits the flow from the reservoir to the point where erosion is arrested, and a breach will not form. This is contingent upon the upstream zone being stable under the flows and having small enough openings to limit flows through the zone to levels that would prevent further erosion of the core. In essence, the flow is limited so that shear stresses are insufficient to detach soil particles.

Fell et al. (2008) suggest that the success of the upstream zone in limiting flows is highly dependent on whether the mechanism leading to a flaw in the core is also present in the upstream zone, with its ability to support a roof or crack of

Chapter D-6 Internal Erosion Risks for Embankments and Foundations

secondary importance. If the potential for the flaw to extend through the upstream zone is high and the potential for the upstream zone to support a roof or crack is high, then flow limitation is unlikely.

Examples of constrictions may include concrete or sheet pile walls within the embankment or that fully penetrate foundation soils greatly increase the likelihood of flows being limited. Modern concrete walls (crossing the internal erosion pathway, typically extending into rock) that are in good condition have the best chance for success. Steel sheet pile walls may be less effective under poor driving conditions or poor construction techniques. Concrete or steel membranes, soil-cement slope protection, geomembranes, or other linings on the upstream face of the dam can be effective in limiting flows, depending on their condition, but potential erosion of the underlying support for the facing may be an issue.

For failure modes that involve seepage paths through bedrock discontinuities, the flow could be limited by the aperture of those discontinuities. Similarly, failure modes in which the seepage flows into a crack or joint in concrete, such as an outlet works conduit, the flow may be limited. However, flow velocities could be quite high, which could lead to stoping (internal migration).

For potential failure modes through the foundation, upstream fine-grained blankets beneath and around the dam may not prevent initiation of erosion but may be effective in limiting progression. Flow limitation may occur due to an increase in head loss across the upstream blanket after uplift of the downstream blanket and initiation of erosion.

In unusual cases, progression could create a large enough void that results in failure of the structure or zone providing the constriction.

D-6.9.3 Progression – No Self-Healing Provided by Upstream Zone

Crack-filling action requires a granular zone upstream of the core with particles of a size, which can be transported by water flowing into the crack or pipe, and a downstream filter/transition zone or rockfill, which is sufficiently fine to act as a filter to these particles and the core.

Upstream granular zones have been observed to help supply crack-filling materials and contribute to self-healing. Typically, sinkholes appeared above the upstream filter/transition zone which is considered to be evidence of material being washed into the crack or pipe. Crack-filling action is only possible for central and sloping core earth and rockfill (or gravel shoulders) dams. The effectiveness of the crack-filling action depends on the compatibility of particle sizes of the granular material upstream of the core and in the downstream

Chapter D-6 Internal Erosion Risks for Embankments and Foundations

filter/transition zone, and then the compatibility of the downstream filter/transition material (with the washed-in particles) and the core. The internal erosion process may be arrested and not lead to breach if the crack or pipe progresses through the core, but there is an upstream zone which can collapse into it (i.e., the upstream zone is not capable of supporting a crack or a roof) and a downstream filter/transition zone which then acts as a filter. The washed-in materials aid in the filtering action against the downstream filter/transition zone, especially in cases of poor filter compatibility between the core and downstream filter/transition zone due to a lack of sand-sized particles in the core. In these cases, the probability of continuation may be high, but the washed-in particles may be capable of filtering against the downstream filter/transition zone reducing the potential for the pipe enlarging. There is less benefit when the washed-in particles are of similar sizes to the core material. There is limited benefit when there is no downstream filter/transition zone. The likelihood of success is difficult to estimate, but probably increases with thicker upstream zones, the presence of truly cohesionless materials, a variety of particle sizes, and the presence of a downstream shell or zone that will provide a filter for these materials that wash into and through the core. Finally, the size and nature of the defect in the core is a consideration (i.e., self-healing may occur early when the defect is a crack or later when the defect is a pipe).

Consideration should be given to whether the self-healing will occur early when the defect is small. In general, it is more likely to self-heal earlier in the process when sand size particles could be carried to downstream zone by relatively low flows. Gravel and larger sizes need high flows to be transported, so by the time flows are large enough to transport these sizes, significant enlargement of the erosion pathway may have already occurred. A well-documented example of this type of self-healing is in a case history for Matahina Dam in New Zealand (Gillon and Newton 1991). Self-healing has also been observed at Suorva Dam in Sweden (Nilsson 2005) and at Uljua Dam in Finland (Kuusiniemi 1992).

D-6.9.4 Unsuccessful Intervention

This event considers the likelihood that human efforts to detect and stop (or slow) the internal erosion process from breaching the embankment fail to work.

This single event evaluates the potential that two components might occur:

1) detection (i.e., whether, or when, a developing failure mechanism would be observed and recognized as a problem); and 2) the ability to successfully intervene (i.e., can mitigating efforts be implemented in time to stop or slow the failure process to the point where dam breach does not occur?). The probability of unsuccessful intervention is typically captured in one event (but could be decomposed into two events of detection and unsuccessful intervention), just before breach, although it is recognized that intervention efforts could occur during all phases of an internal erosion process. When estimating the probability

Chapter D-6 Internal Erosion Risks for Embankments and Foundations

of unsuccessful intervention, it is acceptable to consider factors that would support earlier intervention, chronologically before the failure mode has completed the “progression” events.

Risk estimates must give due consideration for intervention actions. In order for intervention to be successful, the failure path must be detected, and repairs or lowering the water level must be performed prior to breach development. In some cases, it is useful to calculate the risk estimates for both with and without intervention to understand the potential for detection and the benefits of intervention, while at the same time not masking the seriousness of the issue by using intervention to reduce the estimated risk. This may be useful in making the case for additional monitoring or other actions to better understand or reduce the risks. Some levees are designed with planned intervention to achieve acceptable performance.

Experience in the dam safety community indicates that many internal erosion incidents progressed for decades (although they were not recognized as such early on), and that if detected, there is a high rate of successful intervention. For example, only about 1 percent of Reclamation’s incidents involving the initiation of internal erosion have led to dam breach (Teton Dam), and within USACE no incidents have resulted in dam breach. However, USACE has experienced several levee breaches. This success is due to a number of factors involving detection and successfully intervening at various points within the internal erosion process; however, two factors appear to particularly stand out in the tabulated cases.

- First, in most cases, signs of the potential initiation of internal erosion (e.g., sinkholes, sand boils, and excessive seepage) were observed and necessary remedial actions were quickly taken. Internal erosion incidents have typically been discovered by visual observation, sometimes by the public. For this reason, “eyes on the dam” is a key consideration. Is the dam or levee in a remote location? Are likely downstream exit paths observable (consider rockfill, tailwater, marsh areas, beneath blankets, etc.)? How often is the dam or levee visited/observed? How close does the public get? Are local officials (police, park rangers, and recreation staff) trained in dam and levee safety? Few cases have been detected by routine instrumentation monitoring, although it has happened. Over the long-term, piezometer and seepage measurement trends can be indicative of slowly developing internal erosion failure modes.
- Second, there are a number of instances where it appears that self-healing or collapse of developing internal erosion took place and either stopped the process or provided warning such that intervention could take place. This episodic nature of internal erosion incidents, which can lead to these failure mechanisms taking decades to progress (or initiate in some cases), has been demonstrated in all categories of internal erosion, particularly in

Chapter D-6 Internal Erosion Risks for Embankments and Foundations

those involving foundation materials, conduits, or drains. The episodic nature has the benefit of increasing the likelihood of observation, but it can be dangerous because a connection to the reservoir can be sudden, after progressing undetected for a long time.

Evaluating factors related to detection and physical intervention actions is very site-specific and requires judgment and subjective probability estimates (“Chapter A-6, Subjective Probability and Expert Elicitation”). For example, if there is coarse rockfill on the downstream slope or ponding at the toe of the dam, it may be very difficult to detect new muddy seepage. If the reservoir is large and the release capacity is small, attempting to draw the pool down may be of little help. If equipment and materials are not readily available from nearby sources, there may be little that can be done in the way of emergency repairs. These are important items to consider when evaluating detection and intervention. If this event is estimated to have a high likelihood for success, it should be highlighted in the documentation, as this is critical information for the operations of the facility. Even if the estimated likelihood of success is low, it should still be pre-planned and attempted should it occur.

Fell et al. (2001, 2003) studied case histories of failures and accidents for internal erosion in the embankment, foundation, and embankment into the foundation. Based on the case histories and an understanding of the physical processes, they developed guidance on the time for progression beyond when a concentrated leak is first observed and development of a breach. Tables D-6-4 through D-6-6 are based on that study. In these tables, the qualitative terms for rates are defined in table D-6-7. Table D-6-4 could be used to estimate the approximate time to dam failure after a concentrated leak is first observed. Most of the case studies were for breach by gross enlargement. Therefore, the method is only applicable to cases where the breach mechanism is gross enlargement. It is considered reasonable where the final breach is by slope instability, following development of a pipe. It will probably underestimate the time for breach by sloughing since breach by sloughing is a slowly developing mechanism which could take days to weeks to lead to breach. Breach by sinkhole development is potentially a rapid process in the final stages when the sinkhole emerges into the reservoir, but limited case history data exists.

D-6.9.5 Assessing the Rate of Enlargement of a Pipe

The time for erosion to progress is an important factor for assessing the likelihood of successful intervention and is dependent on the soil erosion properties. In addition, breach mechanisms vary in their time to fully develop and catastrophically release the impounded water. Therefore, the likelihood of successful intervention should also consider the potential time available based on the breach mechanism being considered.

Chapter D-6 Internal Erosion Risks for Embankments and Foundations

Table D-6-4.—Rate of Erosion of the Embankment Core or Foundation Soil (adapted from Fell et al. 2001, 2003)

Factors Influencing the Time for Progression and Breach				Approximate Likely Time (Qualitative)	Approximate Likely Time
Ability to Support a Roof	Rate of Erosion (Table D-6-5)	Upstream Flow Limiter	Breach Time (Table D-6-6)		
Yes	R or VR	No	VR or R–VR	Very rapid	< 3 hours
Yes	R	No	R	Very rapid to rapid	3 to 12 hours
Yes	R–M	No	VR	Rapid	12 to 24 hours
Yes	R	No	R–M		
Yes	R	No	M or S	Rapid to medium	1 to 2 days
Yes	R or R–M	No	M or M–S		
Yes	M or R–M	Yes	R or R–M		
Yes	M or R–M	No	S	Medium	2 to 7 days
Yes	R–M or M	Yes	S		
Yes	M	Yes or no	S	Slow	Weeks, even months to years

Table D-6-5.—Rate of Erosion of the Embankment Core or Foundation Soil (used in table D-6-4) (adapted from Fell et al. 2008)

Soil Classification	I_{HET}	Time for Erosion in the Core of the Embankment or in the Foundation	
		0.2-Gradient Along Pipe	0.5-Gradient Along Pipe
SM with < 30% fines	< 2	Very rapid	Very rapid
SM with > 30% fines	2 to 3	Very rapid	Very rapid
SC with < 30% fines	2 to 3	Very rapid	Very rapid
SC with > 40% fines	3	Rapid	Very rapid
ML	2 to 3	Very rapid to rapid	Very rapid
CL-ML	3	Rapid	Very rapid
CL	3 to 4	Rapid	Very rapid to rapid
CL-CH	4	Rapid	Rapid
MH	3 to 4	Rapid	Very rapid to rapid
CH with LL < 65	4	Rapid to medium	Rapid
CH with LL > 65	5	Medium to slow	Medium

Note: I_{HET} is the index value from the HET.

Table D-6-6.—Influence of the Material in the Downstream Zone of the Embankment on the Likely Time for Development of a Breach due to Gross Enlargement of a Pipe (used in table D-6-4) (adapted from Fell et al. 2003)

Material Description	Likely Breach Time
Coarse-grained rockfill	Slow – medium
Soil of high plasticity (PI > 50) and high clay-size content including clayey gravels	Medium – rapid
Soil of low plasticity (PI < 35) and low clay-size content, all poorly compacted soils, silty sandy gravels	Rapid – very rapid
Sand, silty sand, silt	Very rapid

Table D-6-7.—Qualitative Terms for Times of Development of Internal Erosion and Breach (adapted from Fell et al. 2003)

Qualitative Term	Equivalent Time
Slow (S)	Weeks or months, even years
Medium (M)	Days or weeks
Rapid (R)	Hours (> 12 hours) or days
Very Rapid (VR)	< 3 hours

However, the duration of the critical loading is also an important condition, and episodic cycling of the reservoir may result in the progression of erosion occurring only sporadically (at high pool) over the course of weeks, months, years or even decades. This can complicate the assessment of the rate of enlargement significantly.

Procedures detailed in “appendix D-6-I, Rate of Enlargement of a Pipe” may provide useful insights into the development time for erosion progression. However, they not include the effects of pool duration and reservoir cycling.

D-6.9.6 Breach

Breach is the fourth and final phase of internal erosion in which materials in the embankment are eroded, and the opening widens and deepens until an uncontrolled release of impounded water occurs. Additional downcutting or deepening may continue, and the breach enlarges or widens by side erosion and mass wasting of material from the banks of the developing breach. Breach occurs when either the failure mode is not detected, or intervention is not attempted or is unsuccessful. If breach initiates due to internal erosion, it usually leads to complete failure. The full contents of a reservoir may not be lost depending upon many factors (e.g., breach located on an abutment shelf formed by non-erodible rock). Factors that reduce the likelihood of breach include large freeboard, large

Chapter D-6 Internal Erosion Risks for Embankments and Foundations

downstream rockfill zone, presence of a core wall (or similar feature) that remains in place, and a water level that drops below the inlet of a developing pipe before a breach mechanism has time to develop (e.g., reservoir has small storage capacity). The type of breach depends on the internal erosion mechanism being considered, embankment type, and the specific failure mode being considered. According to Fell et al. (2008), there are four breach mechanisms typically considered:

- **Gross enlargement of a pipe or concentrated leak.**—If the erosion pathway or “pipe” connects to the impounded water, rapid erosion and enlargement of the pipe could develop until the crest collapses into the pipe. If the amount of crest drop is greater than the available freeboard, overtopping of the embankment could quickly lead to a breach. If overtopping does not occur, the embankment could be severely damaged, and breach could still occur by concentrated flow through cracks. If the likely breach mechanism for a potential failure mode is breach by gross enlargement, as opposed to sinkhole development or sloughing, a breach is generally more likely to occur. If the downstream or landside shell is unable to support a roof, sloughing or unraveling would be the more likely breach mechanism.
- **Sloughing or unraveling of the downstream face.**—In situations where the downstream or landside zone is not capable of sustaining a roof, over-steepening of the downstream or landside slope due to progressive slumping can eventually lead to complete loss of freeboard. Soil particles are eroded, and a temporary void grows near the downstream or landside face until a roof can no longer be supported, at which time the void collapses. This mechanism is repeated progressively until the core is breached or the slope is over-steepened to the point of instability. Unraveling refers to progressive removal of individual rocks by large seepage flows through a downstream rockfill zone. According to Leps (1973), the stability of rockfill against through-seepage depends on the following characteristics and conditions (listed in increasing importance): specific gravity of the rock particles, dominant particle size of the rock fill, gradation and shape of the rockfill particles, relative density of the rockfill, rate of discharge, maximum gradient, and inclination of the downstream slope of the rock fill. Methods to evaluate the stable rock size as a function of unit discharge and downstream slope include Olivier (1967), Solvik (1991), and EBL (2005).

Reclamation’s Fontenelle Dam nearly breached in 1965 by sloughing, but the breach process occurred slowly enough so that the reservoir water surface was able to be lowered over the span of several days and arrest the breach. In contrast, Hell Hole Dam, a rockfill structure in California, failed from overtopping during construction in 1964, but it handled a leakage of about 13 cfs/ft before small slides and erosion began to progressively occur at the toe. Once this began, failure occurred within about 3.5 hours (Leps 1973).

Chapter D-6 Internal Erosion Risks for Embankments and Foundations

The core of Reclamation's Minidoka Dam overtopped during construction (1904 to 1906), and the downstream rockfill zone withstood flows estimated up to 1,000 cfs. The water surface elevation was 8 feet below the normal water surface when the core overtopped.

- **Sinkhole development.**—This mechanism refers to stoping of material upward, creating a sinkhole or depression in the embankment that compromises the embankment or lowers the crest below the impounded water level. For breach to occur, the sinkhole would need to be large enough to lead to overtopping. USACE's Wolf Creek Dam in Kentucky was constructed over karst features and has experienced numerous sinkholes. Due in part to concern that sinkholes may lead to potential breach; major mitigation measures have been completed.
- **Slope instability.**—Internal erosion could cause high pore pressures in the foundation or embankment, resulting in reduced shear strength and slope failure. Breach could occur if the failure surface either intersects the impounded water level, or the slope deformations are significant enough that the remnant can't resist the water load. Although it is possible, this is generally not considered to be a very likely breach mechanism for most dams. No historical failures from slope instability due to increased pore pressures in the downstream slope are known to exist, and a unique set of circumstances would need to exist for it to be a major concern.

All four mechanisms lead to crest settlement and overtopping erosion. One or more of the mechanisms may occur during the breach process, and it is generally not necessary to know precisely which mechanism(s) would occur. However, risk estimates should typically be developed considering the most likely breach mechanism(s).

There are a few cases where once failure has initiated and progressed, and intervention has been unsuccessful, complete breach of the dam did not necessarily follow. Many Reclamation and USACE dams have large flood storage resulting in large normal freeboard. If the operative breach mechanism was stoping (forming a sinkhole near the crest) or progressive slumping and erosion at the toe of the dam during periods when the reservoir is low, the large freeboard may prevent failure by keeping the sinkhole above the reservoir surface, or by formation of a "berm" at the downstream slope from the slumped material that ultimately arrests breach development. In addition to large freeboard, other factors that have led to a reduced probability of complete breach include a concrete corewall to nearly full dam height (which is capable of retaining the reservoir even if a "pipe" or sinkhole develops). In the case of internal instability of core material, not only must the finer particles be washed through the coarser materials, but the remaining fraction must sustain enough flow such that it is also completely eroded. It is also possible that a small reservoir volume may empty through an opened seepage path before complete dam breach can occur. Breach

mechanisms vary in their time to fully develop and catastrophically release the reservoir, and the intervention node should consider the potential time available based on the breach mechanism being considered.

D-6.9.7 Accounting for Uncertainty

Given the difficulties in quantifying seepage and internal erosion behavior, there is a high degree of uncertainty in the estimates. Sensitivity analysis or other appropriate uncertainty analysis methods can be used to explicitly show how uncertainty influences the risk estimate.

D-6.9.8 Relevant Case Histories

A summary overview of several key incidents is provided below, starting from early history to the present, illustrating that internal erosion can occur at virtually any time during the operational life of an embankment dam (Engemoen and Redlinger 2009).

D-6.9.8.1 Avalon Dam

Avalon Dam in New Mexico failed twice; once in 1893 from flood overtopping and later in 1904 from internal erosion. After the second failure, Avalon was taken over by Reclamation and reconstructed in 1907. Although this dam was not part of Reclamation's inventory when it failed, it was one of Reclamation's earliest dealings with an internal erosion incident. Avalon Dam was one of several dams built in the late 1800's or early 1900's that featured a rockfill downstream section which buttressed an upstream earthfill zone. It is notable that a number of failures or serious incidents occurred at other non-Reclamation dams having this similar configuration, including McMillan Dam (Idaho), Black Rock Dam (Pennsylvania), and Fish Lake Dam (Oregon). In all these cases, a seepage path existed through their earthfill zone that flowed down into underlying rockfill. The exact cause of failure of Avalon Dam is unclear, but explanations included piping of the embankment due to the severe incompatibility of the earthfill and rockfill from a filtering/retention perspective, or erosion at the base of the earthfill due to flows in the upper portion of the limestone foundation.

D-6.9.8.2 Fontenelle Dam

A very serious internal erosion incident occurred in 1965, when Fontenelle Dam nearly failed during first filling. Significant seepage traveled through the open jointed sandstone foundation rock, emanating 2,000 feet downstream in a low area as well as in the right abutment near the spillway. Seepage led to the erosion of more than 10,000 cubic yards of embankment materials before the intervention efforts of large outlet works releases and dumping of rockfill into the embankment erosion area eventually lessened the flows and the erosion. Fortunately, the large

Chapter D-6 Internal Erosion Risks for Embankments and Foundations

capacity outlet works was able to lower the reservoir by approximately 4 feet per day, quickly reducing the head at the abutment area where internal erosion was occurring. In less than two days of drawdown, the reservoir was lowered off of the spillway approach channel which undoubtedly was feeding seepage into the problem area. The primary cause of the near failure was thought to be inadequate grouting of the jointed sandstone and the lack of foundation treatment measures such as slush grouting and dental concrete, which led to seepage near the base of the dam that removed embankment material and led to the growth of voids and stoping. Contributing factors included the presence of infilling or soluble material in the jointed rock that may have inhibited grout travel; residual or redeposited soluble salts in the rock that may have reacted with the grout causing premature set or ultimate softening; the erodible nature of the embankment core material; and a steep right abutment that created difficulties in achieving good bond or contact between the embankment and abutment, encouraged differential settlement and cracking of the embankment, and made shallow grouting difficult because low pressures were required to prevent movement of the rock.

Another factor not mentioned in early reports was the unfavorable orientation of the abutment with respect to the potential for hydraulic fracturing. In hindsight, an obvious key factor in the near failure, in addition to the lack of sufficient foundation treatment, was the lack of an internal filter and drainage zone that would render seepage through both the foundation and embankment harmless with respect to the removal of soil particles and the buildup of pore pressures. A couple of key details are that the average zone 1 core material in the dam is reported as being a SC and CL with 13 percent plus No. 4 material and having a LL of 31 and a PI of 13. However, the core material remaining after the near breach in the abutment area was generally described as a well graded mixture of sandy gravel and silt. No crack in the core was noticed during close inspection of the piping channel through the zone 1. Zone 2 materials described as select sand, gravel and cobbles as well as the materials in the miscellaneous zone sloughed during this incident and an incident that occurred four months prior and were easily removed by the concentrated seepage.

D-6.9.8.3 Teton Dam

Teton Dam failed from internal erosion during first filling in 1976, marking the first and only failure of a Reclamation embankment dam. The failure was similar to the incident at Fontenelle Dam 11 years earlier, with excessive seepage through a highly jointed foundation rock leading to erosion of a highly erodible core material during initial reservoir filling. Contributing factors included a low permeability transition zone that contained too many fines to act as a drain for the core or serve as a filter, the lack of foundation filters on the downstream face of the cutoff/key trenches, insufficient treatment of the open joints in the rock foundation, the presence of a highly erodible core material, the rapid rate of initial reservoir filling, and an inoperable outlet works. Reports were prepared by an independent panel and a Government panel assembled to review the cause of failure.

Chapter D-6 Internal Erosion Risks for Embankments and Foundations

There have been a number of reasons given as to how a defect in the core materials deep within the right abutment cutoff trench came about; some are as simple as resulting from the fill becoming frozen during winter shut down to more complex theories related to low stress zones and hydraulic fracturing caused by arching of the dam over the steep narrow cutoff trench. However, it is critical to recognize that the joints, fractures and openings in the downstream wall of the cutoff trench and the remaining foundation downstream of the trench were severely incompatible with respect to filtering and retention of the very fine grained, erodible core materials, as well as the silt infillings in some of the joints themselves. It would have been virtually impossible to construct a perfect core without defects to overcome these conditions, and the focus should have been on proper foundation treatment and filter protection for the core and the silt infillings.

D-6.9.8.4 Caldwell Outlet Works at Deer Flat Dams

The Caldwell Canal outlet works, with a capacity of 70 cfs, is a cut-and-cover conduit located through the left abutment section of the Upper Embankment at Deer Flat Dams in Idaho, and was completed in 1908. The foundation materials in the vicinity of the Caldwell conduit consist of mostly poorly graded sand and silty sand with some gravel. Caliche layers exist in some areas of the dam's foundation as well. A dam safety inspection in 2001 (93 years after construction) noted some sediments in the seepage from a crack in the conduit located 65 feet upstream of the outlet portal. A large sand deposit approximately 6 feet wide by 15 feet long and 10 to 12 inches deep was observed downstream of the outlet structure. Although speculated to be windblown materials, it was also judged possible that the observed sediments could have been materials transported into the conduit by seepage flows. Then, in 2004 sediment was observed at the base of a crack in the conduit approximately 125 feet downstream of the regulating gate. Subsequently, ground penetrating radar was utilized in the conduit, and potential anomalies were detected between 100 and 150 feet downstream of the gate. Follow-up drilling through the conduit revealed voids beneath the conduit varying from ½-inch to 5 inches in depth, presumably caused by internal erosion of foundation soils into or along the conduit. Piezometers installed below the conduit revealed consistently low pressures similar to tailwater levels beneath the conduit from the downstream portal upstream to within 20 feet of the intake. It was concluded that backwards erosion piping had occurred along most of the conduit, with potentially high gradients existing at the upper end of the conduit. A large upstream berm was constructed to minimize the potential for upstream breakout of the piping pathway to the reservoir, until permanent corrective actions could be taken.

In the case of Upper Deer Flat Dam, even though in general there are gravels present in the embankment fill as well as the foundation, gravel sized particles were found to be absent over a large extent of the conduit foundation during the re-construction. Even if coarser particles were present in the soil mass, the

Chapter D-6 Internal Erosion Risks for Embankments and Foundations

mechanism of a soil filtering against a crack in the bottom of a conduit can be complicated by the fact that a flow path beneath the structure will not necessarily transport coarser particles up into or against the crack in the bottom of the conduit. Any particles transported to such a crack may drop away during times of lower gradients such as under lower reservoir operating conditions. Therefore, caution against the use of liberal filter/retention criteria in such a case is advised.

D-6.9.8.5 A.V. Watkins Dam

A.V. Watkins Dam (formerly known as Willard Dam) is a U-shaped (in plan view) zoned earthfill structure constructed within Willard Bay of the Great Salt Lake. Constructed from 1957 to 1964, the dam is 36 feet high at its maximum section and slightly more than 14.5 miles long. Upon first filling of the reservoir in 1965, as the reservoir reached within approximately 2 feet from full, numerous wet areas (with some areas displaying quick conditions) appeared at the downstream toe of the dam. After this discovery, filling of the reservoir was halted, the reservoir was lowered and a toe drain was constructed approximately 15 feet from the downstream toe from 4 to 5 feet deep in the foundation, consisting of 8-inch diameter bell and spigot concrete pipe with open joints and surrounded by gravel. Toe drain outfalls were constructed at approximate 1,000-foot intervals to discharge into the South Drain; a long open ditch excavated about 130 feet downstream of the dam toe to help drain farm land as well as seepage. The toe drain was apparently successful in drying up the downstream toe area and the reservoir was eventually filled to the top of active conservation water surface.

In November of 2006, A.V. Watkins Dam nearly failed at a location in the same general area that created problems during initial filling, as the result of piping and internal erosion of the foundation soils. Two days previously, a local cattle rancher working just downstream of the incident area noticed seepage and some silty material exiting from the cut slope of the South Drain. The rancher continued to observe the seepage and erosion into the South Drain until Monday, November 13, when he became concerned over the increase in seepage and the appearance of what he described as “dark clay” exiting into the South Drain. He called authorities and Reclamation began 24-hour monitoring and initiation of an emergency drawdown of the reservoir. Piping of the foundation soils was occurring from beneath the dam below a somewhat continuous downstream, but absent upstream, series of thin hardpan layers, and the fine-grained, silty sand soils were exiting from the dam’s downstream toe and from the base of the north slope of the South Drain. Approximately 140 to 190 gallons per minute of seepage was exiting from sand boils at the downstream toe of the embankment (but upstream of the toe drain), flowing across the ground surface and into sinkholes between the toe of the embankment and the South Drain. The seepage appeared to be re-emerging at the base of the bank of the South Drain and was depositing large amounts of sand into the South Drain. Figure D-6-22 depicts the conditions.

Chapter D-6 Internal Erosion Risks for Embankments and Foundations

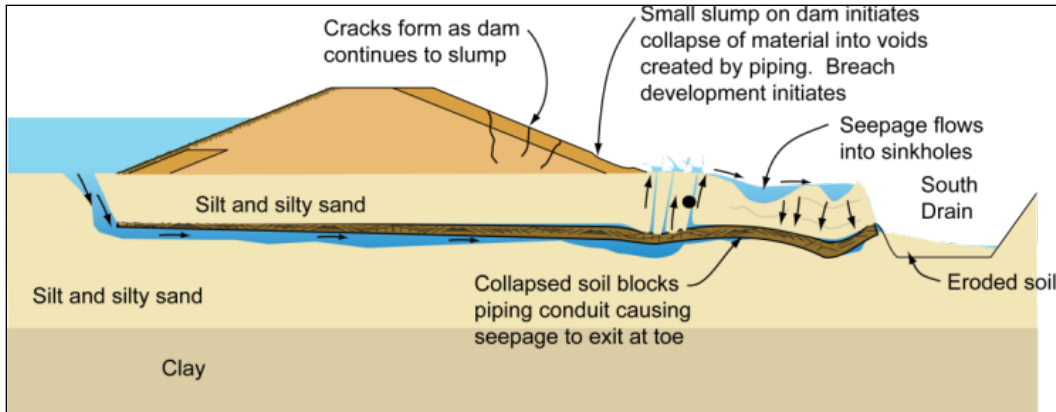

Figure D-6-22.—Failure mode in-progress (not to scale).

Efforts to save the dam focused immediately on transportation of filter sand and gravel materials to the site to begin placement of these soils directly over the sand boils in an attempt to stop the erosion of foundation soils. Initially filter sand was placed over the sand boils but that was quickly washed away due to the high exit velocities. Gravels were then placed over the sand boils until the exit velocities were reduced enough to allow placement of the filter sand. This reduced the flow and erosion of soil enough to allow the placement of a sufficiently large berm consisting of additional filter material, drainage material, and minus 5-inch pit-run material, to counter the uplift pressures in the emerging seepage at the toe.

On November 16, Reclamation technical staff determined the failure mode was still in progress and additional remedial action was required. It was noticed that seepage and erosion was still occurring into the South Drain. On November 17 and 18, a berm was added to the upstream slope of the embankment extending into the reservoir to stem the flow of the water into the foundation and any inlets to potential piping channels (located just beyond the upstream dam toe and within the riprap) that were postulated to be the sources for the concentrated seepage entering the foundation. These efforts were successful in stopping the foundation erosion and immediately reducing the overall seepage flows. Some key lessons learned at this dam to consider in future dam designs and risk analysis are:

- Internal erosion can initiate, progress and nearly fail a dam with an erodible foundation at very low head to seepage length ratios, in this case generally about 0.09 (locally may have been about 0.06 due to rodent holes), if the exit point for the unfiltered seepage is nearly horizontal, the soil is highly erodible, and a roof is present.
- Rodent activity can suddenly aggravate a meta-stable seepage situation, as rodents can fairly quickly excavate a burrow and shorten a potential seepage path, compared to the more gradual particle transport caused by seepage at these low gradients.

Chapter D-6 Internal Erosion Risks for Embankments and Foundations

- Construction of open trenches downstream of the toe of a dam provides a location into which materials can be eroded.
- Toe drains installed as the primary defense against foundation internal erosion, especially when the drain is installed after an occurrence of piping was observed, can be critical to the performance of the structure. Plugging of the toe drains appeared to have been occurring at this site. It is not clear that the toe drain plugging was a significant contributor to the occurrence of the incident.
- Changes to seepage conditions that occur over a long period of time can be difficult to recognize and the knowledge about the presence of buried drains can be lost. Consideration should be given to estimating risks for (or at least considering as a potential failure mode) every location that seepage or wet spots are known to exist at a dam, as well as those areas typically analyzed (see Bliss and Dinneen 2007).

D-6.9.8.6 Stilling Basin at Davis Creek Dam

Davis Creek Dam is a modern embankment dam in Nebraska, completed by Reclamation in 1990. A sinkhole was reported adjacent to the outlet works on May 11, 2007. The sinkhole was located against the left side of the outlet works control house immediately upstream of the stilling basin, and measured approximately 5 feet along the wall, 2 feet wide away from the wall and about 6 feet deep. The sinkhole was located in the structural backfill composed of fine to medium sands. The perimeter of the sinkhole was probed with a steel rod, which could be inserted with ease vertically along the wall in the sand to a depth of about 10 feet below the bottom of the sinkhole or about 16 feet below the original ground surface. Subsequent video inspections of the spillway underdrain system found sand in the drain pipes. Due to a defect in the underdrain system, whether from broken pipe or inadequately constructed filters, structural backfill, filter sand, and possibly foundation sands were being internally eroded into the underdrain system and then removed downstream by the action of the drains during outlet works operation. A grouting operation was subsequently undertaken, and it took more than 20 cubic yards of grout to fill voids beneath the stilling basin and surrounding areas. The precise location and lateral extent of the void system could not be defined, and it is uncertain if the erosion had progressed upstream along the outlet works beyond the limit of the upstream edge of the sinkhole. A filtered drainage system was also constructed around the sides of the basin to encourage drainage and thus reduce uplift pressures.

The underdrains were installed to assist in preventing floatation of the stilling basin structure both during dewatering of the stilling basin and during operations should the hydraulic jump move downstream. They were constructed such that during certain operating conditions outlet works discharges running by the drain outlets created low pressures thus resulting in drain flow and lowered uplift

pressures. Vents were installed to ensure negative pressures did not develop. This fairly sophisticated drain system, if damaged, can apparently be very efficient in causing particle transport from the foundation. Since the operations of the outlet are intermittent, removal of soil would be intermittent and could occur over a long period of time. The typical winter seepage regime could have primed the system with water and soil particles and then the underdrains could have nearly instantaneously removed the water and some soil from beneath the structure each year under certain operating conditions. Hydraulic connection of the stilling basin to the groundwater was potentially causing very severe transient seepage conditions and particle transport.

D-6.9.8.7 Wister Dam

Wister Dam, Oklahoma was a severe case of differential foundation settlement likely causing cracks in the embankment (flaws) that skewed across the dam aligned with soils left in the foundation resulting in concentrated leaks and scour. Concentrated leakage was not observed until the reservoir rose above the entrance to the cracks which supports the need to consider whether or not flaws exist above historic maximum pools. The amount of leakage was increasing while the reservoir was being lowered indicating that erosion was continuing and progressing. The design did not provide a defense for either of these phases at the location the cracks existed as the scoured material was transported completely through the embankment above the ineffective drainage blanket. Intervention included lowering the reservoir below the entrance to the cracks which caused leakage to cease thus preventing further damage and possible failure of the dam. Embankment soils were later found to be dispersive which indicates they were likely very erodible. The differential head to estimated seepage path length along the skew was estimated to be about 1/50 or 0.02. Sherard used the term “concentrated leakage” to describe the flow out the downstream face of the embankment.

D-6.9.8.8 Pishkun Dikes

Pishkin Dikes is a case of internal migration. In June 1997 the Greenfields Irrigation District staff discovered a sinkhole adjacent to the concrete air shaft associated with the outlet works at Dike 4. Subsequent investigations revealed that embankment materials were moving into the outlet works conduit and the sinkhole had grown to about 12 feet in depth and extended beneath the outlet works gate house structure. The problem was traced to structural failure and collapse caused by deterioration of the 6-inch-thick concrete walls at the bottom of the air shaft. Freeze-thaw and a possible poor first lift of concrete were conjectured as the reason the concrete failed. The opening in the concrete allowed embankment material to migrate into the shaft which connects into the outlet works conduit area located immediately downstream of the slide gates. The sinkhole was excavated, the air shaft was filled with lean

Chapter D-6 Internal Erosion Risks for Embankments and Foundations

concrete and a new pipe was installed to supply air to the downstream side of the gates. The embankment was repaired with processed sand and gravel filter material.

D-6.9.9 Example

Given the gradation curves shown on the figure D-6-23, estimate the probability of NE, some erosion, excessive erosion (EE), and CE for the fine, average, and coarse Zone 1 base soil gradations. Assume the representative gradations of the re-graded base soil corresponds to 90 percent all gradation tests.

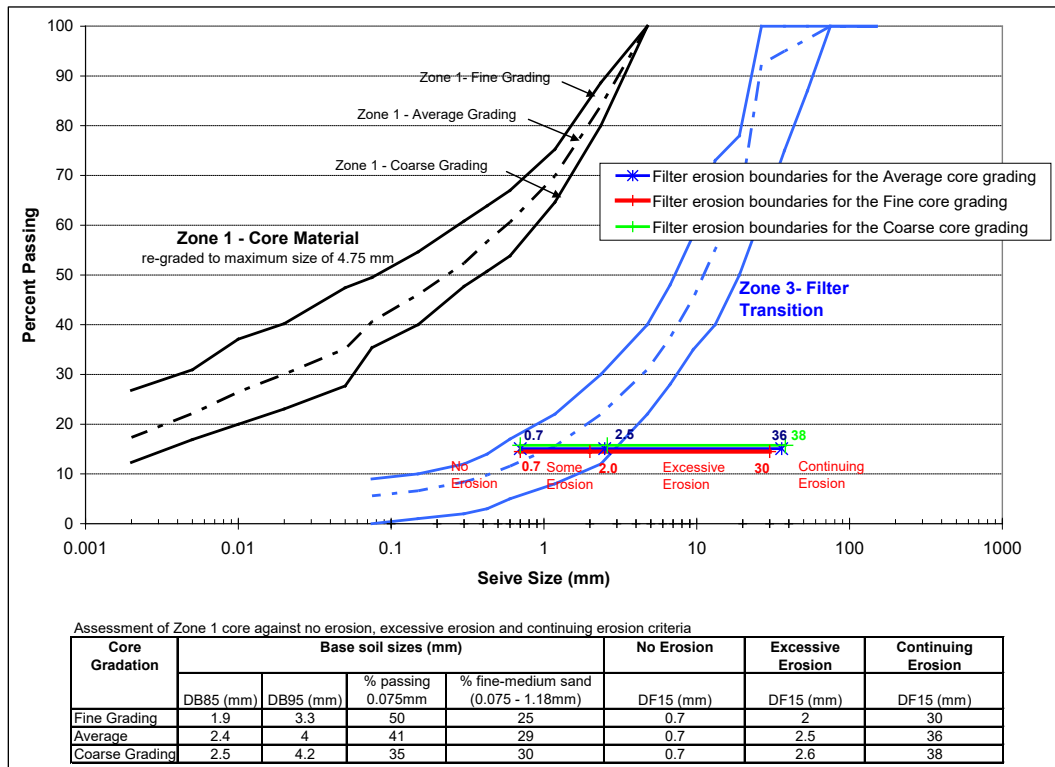

Figure D-6-23.—Example.

D-6.10 References

Ammerlaan, P.R.M. 2007. “Levees and Levee Evaluation, the Dutch and U.S. Practice Compared, MSc-thesis, Delft University of Technology, Delft, Netherlands.

Annandale, G.W. 2007. “How Does Water-Soil Interaction Lead to Erosion?” *Proceeding of the Geotechnics of Soil Erosion*, American Society of Civil Engineers (ASCE) Geo-Congress.

Chapter D-6 Internal Erosion Risks for Embankments and Foundations

- Béguin, R., C. Guidoux, Y.H. Faure, and C.C. Ho. 2009. Stability Conditions and Erosion Rates at the Contact Between Two Soils, Subjected to a Water Flow Parallel to the Interface,” presentation at International Commission on Large Dams (ICOLD) European Working Group on Internal Erosion, St. Petersburg, Russia.
- Bligh, W.G. 1910. “Dams, Barrages, and Weirs on Porous Foundations,” *Engineering News Record*, Vol. 64, No. 20, pp. 708-710.
- Bliss, M., and E.A. Dinneen. 2007. “Emergency Remedial Actions at A.V. Watkins Dam,” Proceeding of the Technical Groups 33/1, Institution of Professional Engineers, Queenstown, New Zealand.
- Bonelli, S. 2013. *Erosion in Geomechanics Applied to Dams and Levees*, Wiley, Hoboken, New Jersey.
- Brauns, J. 1985. “Erosionsverhalten Geschichteten Bodens bei Horizontaler Durchstromung,” *Wasserwirtschaft*, Vol. 75, pp. 448–453.
- Bureau of Reclamation. 2011. “Chapter 5: Protective Filters – Design Standards No. 13 Embankment Dams,” Bureau of Reclamation, Denver, Colorado.
- Burenkova, V.V. 1993. “Assessment of Suffusion in Non-Cohesive and Graded Soils,” Proceeding of the First International Conference of Geo-Filters, Filters in Geotechnical and Hydraulic Engineering, Karlsruhe, Germany.
- CIRIA. 2013. *International Levee Handbook*, Construction Industry Research and Information Association, London, United Kingdom.
- de Wit, J.M., J.B. Sellmeijer, and A. Penning. 1981. *Laboratory Testing on Piping, Soil Mechanics and Foundation Engineering*, Rotterdam, Netherlands.
- EBL. 2005. *Stability and Breaching of Embankment Dams*, Report on Sub-Project 2: Stability of Downstream Shell and Dam Toe during Large Flow-Through, Publication No. 186-2005, EBL Kompetanse AS, Norway.
- Engemoen, W.O. 2011. “Bureau of Reclamation Experiences with Internal Erosion Incidents,” Proceeding of the Internal Erosion in Embankment Dams and Their Foundations, European Working Group of International Commission on Large Dams (ICOLD), Brno, Czech Republic.
- _____. 2017. “Latest Compilation of Internal Erosion Incidents at Bureau of Reclamation Dams,” Proceeding of the 37th Annual USSD Conference, United States Society on Dams, Anaheim, California, 433-450.

Chapter D-6 Internal Erosion Risks for Embankments and Foundations

- Engemoen, W.O., and C.G. Redlinger. 2009. "Internal Erosion Incidents at Bureau of Reclamation Dams," International Commission on Large Dams, 29th USSD Annual Meeting and Conference, United States Society on Dams, Nashville, Tennessee.
- Fell, R. 2016. Personal communication, USSD International Symposium on the Mechanics of Internal Erosion for Dams and Levees, United States Society on Dams, Salt Lake City, Utah.
- Fell, R., C.F. Wan, J. Cyganiewicz, M.A. Foster. 2001. Time for Development and Detectability of Internal Erosion and Piping in Embankment Dams and Their Foundations. UniCiv Report R-399, University of New South Wales, Sydney, Australia.
- _____. 2003. "Time for Development of Internal Erosion and Piping in Embankment Dams," *Journal of Geotechnical and Geoenvironmental Engineering*, American Society of Civil Engineers, Vol. 129, No. 4, pp. 307-314.
- Fell, R., C.F. Wan, and M.A. Foster. 2004. Methods for Estimating the Probability of Failure of Embankment Dams by Internal Erosion and Piping: Piping through the Embankment, UniCiv Report No. R-428, University of New South Wales, Sydney, Australia.
- Fell, R., M.A. Foster, J. Cyganiewicz, G.L. Sills, N.D. Vroman, and R.R. Davidson. 2008. Risk Analysis for Dam Safety: A Unified Method for Estimating Probabilities of Failure of Embankment Dams by Internal Erosion and Piping, URS Australia, Sydney, Australia.
- Fell, R., P. MacGregor, D. Stapledon, G. Bell, and M. Foster. 2014. Geotechnical Engineering of Dams, Second Edition, CRC Press/Balkema, London, United Kingdom.
- Federal Emergency Management Agency (FEMA). 2008. Training Aids for Dam Safety, Federal Emergency Management Agency, Washington, DC.
- _____. 2005. Conduits through Embankment Dams: Best Practices for Design, Construction, Problem Identification and Evaluation, Inspection, Maintenance, Renovation and Repair, Federal Emergency Management Agency, Washington, DC.
- _____. 2011. Filters for Embankment Dams: Best Practices for Design and Construction, Federal Emergency Management Agency, Washington, DC.
- FEMA (see Federal Emergency Management Agency).

Chapter D-6 Internal Erosion Risks for Embankments and Foundations

- Foster, M.A. 1999. The Probability of Failure of Embankment Dams by Internal Erosion and Piping, Ph.D. thesis, University of New South Wales, Sydney, Australia.
- Foster, M.A., and R. Fell. 1999. Assessing Embankment Dam Filters That Do Not Satisfy Design Criteria, UNICIV Report No. R-376, University of New South Wales, Sydney, Australia.
- _____. 2001. "Assessing Embankment Dam Filters That Do Not Satisfy Design Criteria," *Journal of Geotechnical and Geoenvironmental Engineering*, American Society of Civil Engineers, Vol. 127, No. 5, pp. 398-407.
- Foster, M.A. R. Fell, and M. Spannagle. 2000. "The Statistics of Embankment Dam Failures and Accidents," **Canadian Geotechnical Journal**, National Research Council, Canada, Vol. 37, No. 5, pp. 1000-1024.
- Foster, M.A., M. Spannagle, and R. Fell. 1998. Report on the Analysis of Embankment Dam Incidents, UniCiv Report No. R-374, University of New South Wales, Sydney, Australia.
- Galloway, D., D.R. Jones, and S.E. Ingebritsen. 1999. "Land Subsidence in the United States," *Circular 1182*, U.S. Geological Survey, Denver, Colorado.
- Garner, S.J. and R.J. Fannin. 2010. "Understanding Internal Erosion: A Decade of Research Following a Sinkhole Event," *International Journal on Hydropower and Dams*, Aqua~Media International, Vol. 17, No. 3, pp. 93-98.
- Gillon, M.D. and C.J. Newton. 1991. "Abutment Repairs at the Matahina Dam," 1991, Proceedings, 17th ICOLD Congress (Q56, R50) Vienna, Austria.
- Guidoux, C., Y.H. Faure, R. Beguin, and C.C. Cho. 2010. "Contact Erosion at the Interface between Granular Coarse Soil and Various Base Soils under Tangential Flow Condition," *Journal of Geotechnical and Geoenvironmental Engineering*, American Society of Civil Engineers, Vol. 136, No. 1, pp. 741-750.
- International Commission on Large Dams (ICOLD). 1974. Lessons from Dam Incidents, International Commission on Large Dams, Paris, France.
- _____. 1994. Embankment Dams: "Granular Filters and Drains," *Bulletin No. 95*, International Commission on Large Dams, Paris, France.
- _____. 1995. "Dam Failures – Statistical Analysis," *Bulletin No. 99*, International Commission on Large Dams, Paris, France.

Chapter D-6 Internal Erosion Risks for Embankments and Foundations

- _____. 2015. "Internal Erosion of Existing Dams, Levees, and Dikes, and Their Foundations," *Bulletin 164 Preprint*, International Commission on Large Dams, Paris, France.
- Kenney, T.C. and J. Westland. 1993. "Laboratory Study of Segregation of Granular Materials," Proceedings of the 1st International Conference, Geo-Filters, Geotechnical and Hydraulic Engineering, Balkema, Rotterdam.
- Kenney, T.C. and D. Lau. 1986. "Internal Instability of Granular Filters: Reply," *Canadian Geotechnical Journal*, National Research Council, Canada, Vol. 23, No. 3, pp. 420-423.
- Kenney, T.C. and D. Lau. 1985. "Internal Instability of Granular Filters," *Canadian Geotechnical Journal*, National Research Council, Canada, Vol. 22, No. 2, pp. 215-225.
- Kézdi, A. 1979. "Soil Physics- Selected Topics," *Elsevier Scientific*, Amsterdam, Netherland.
- Koenders, M.A. and J.B. Sellmeijer. 1992. "Mathematical Model for Piping," *Journal of Geotechnical Engineering*, American Society of Civil Engineers, Vol. 118, No. 6, pp. 943-946.
- Kovács, G. 1981. "Seepage Hydraulics," *Elsevier Scientific*, Amsterdam, Netherland.
- Koženy, J. 1953. *Hydraulik: Ihre Grundlagen und Praktische Anwendung*. Springer-Verlag, Vienna, Austria.
- Kuusiniemi, R. 1992. Internal erosion at the Uljua Earth Dam, *Water Power and Dam Construction*. March 1992.
- Lane, E.W. 1935. "Security from Underseepage," *Transactions of the American Society of Civil Engineers*, Vol. 100, pp. 1235-1351.
- Leps, T.M. 1973. "Flow through Rockfill," *Embankment-Dam Engineering, Casagrande Volume*, John Wiley and Sons, Malabar, Florida, pp. 87-107.
- Li, M. and J. Fannin. 2008. "Comparison of Two Criteria for Internal Stability of Granular Soil," *Canadian Geotechnical Journal*, National Research Council Canada, Vol. 45, No. 9, pp. 1303-1309.
- Marot, D., A. Rochim, H.H. Nguyen, F. Bendahman, and L. Sibille. 2014. "Systematic Methodology for Characterization of Suffusion Sensibility: Scour and Erosion," Proceedings of the 7th International Conference on Scour and Erosion, Perth, Australia, 213-223.

Chapter D-6 Internal Erosion Risks for Embankments and Foundations

- Marot, D., V.D. Le, J. Garnier, L. Thorel, and P. Audrain. 2012. "Study of Scale Effect in an Internal Erosion Mechanism," *European Journal of Environmental and Civil Engineering*, Vol. 6, No. 1, pp. 1–19.
- Marot, D., P-L. Regazzoni, and T. Wahl. 2011. "Energy-Based Method for Providing Soil Surface Erodibility Rankings," *Journal of Geotechnical and Geoenvironmental Engineering*, American Society of Civil Engineers, Vol. 137, No. 12, pp. 1290-1293.
- Nilsson, A. 2005. "The Susceptibility of Internal Erosion in the Suorva Dam," Workshop on Internal Erosion of Dams and Their Foundations, Aussois, France, 25-27. April 2005.
- Olivier, H. 1967. "Through and Overflow Rockfill Dams – New Design Techniques," *Proceedings of the Institution of Civil Engineers*, Vol. 36, No. 3, pp. 433-471.
- Pabst, M.W., W.O. Engemoen, D.L. Hanneman, C.G. Redlinger, and G.A. Scott. 2013. "Heave, Uplift, and Piping at the Toe of Embankment Dams," *Journal of Dam Safety*, Association of State Dam Safety Officials, (11)2, 21-31.
- Park, Y. 2003. "Investigation of the Ability of Filters to Stop Erosion through Cracks in Dams," Ph.D. thesis, Virginia Polytechnic Institute and State University, Blacksburg, Virginia.
- Reddi, L.N., I. Lee, and M.V.S. Bonala. 2000. Comparison of Internal and Surface Erosion Using Flow Pump Test on a Sand-kaolinite Mixture. *Geotechnical Testing Journal*, 23(1), 116-122.
- Redlinger, C.G., T.M. O’Leary, K.H. Henn, and G.A. Scott. 2011. "Current Methodology and Research at the [Army] Corps of Engineers for Assessing Internal Erosion Risks of Dams," *Proceedings of the Internal Erosion in Embankment Dams and Their Foundations*, European Working Group of International Commission on Large Dams, Brno, Czech Republic.
- Robbins, M.A. and M.K. Sharp. 2016. "Incorporating Uncertainty into Backward Erosion Piping Risk Assessments," *Proceedings of the 3rd European Conference on Flood Risk Management, FLOODrisk 2016*, Article 03007, pp. 1-6.
- Robbins, B.A. and V.M. van Beek. 2015. "Backwards Erosion Piping: A Historical Review and Discussion of Influential Factors," *Proceedings of Dam Safety 2015*, Association of State Dam Safety Officials, New Orleans, Louisiana.

Chapter D-6 Internal Erosion Risks for Embankments and Foundations

- Schmertmann, J.H. 2000. "The No-Filter Factor of Safety Against Piping through Sands," *ASCE Geotechnical Special Publication – Judgment and Innovation: The Heritage and Future of the Geotechnical Engineering Profession*, No. 111, American Society of Civil Engineers, pp. 65-132.
- Schmitz, S. 2007. "Zur Hydraulischen Kontakterosion bei Bindigen Basiserdstoffen," Ph.D. thesis, Universität der Bundeswehr, Munich, Germany.
- Sellmeijer, J.B. 1988. "On the Mechanism of Piping under Impervious Structures," Ph.D. thesis, Delft University of Technology, Delft, Netherlands.
- Sellmeijer, J.B., and M.A. Koenders. 1991. "A Mathematical Model for Piping," *Applied Mathematical Modeling*, Vol. 115, No. 6, pp. 646-651.
- Sellmeijer, J.B., H. López de la Cruz, V.M. van Beek, and J.G. Knoeff. 2011. "Fine-Tuning of the Backward Erosion Piping Model through Small-Scale, Medium-Scale and Ijkdijk Experiments," *European Journal of Environmental and Civil Engineering*, Vol. 15, No. 8, pp. 1139-1154.
- Sherard, J.L. 1985a. Memorandum 1A to 1H. Unpublished Reports of Filter Research. U.S. Soil Conservation Service, Soil Mechanics Laboratory, Lincoln, Nebraska.
- Sherard, J.L. 1985b. "Hydraulic Fracturing in Embankment Dams, Seepage and Leakage from Dams and Impoundments," American Society of Civil Engineers Geotechnical Engineering Division Conference.
- Sherard, J.L. 1979. "Sinkholes in Dams of Coarse, Broadly Graded Soils," Proceedings of 13th ICOLD Congress, International Commission on Large Dams, New Delhi, India.
- Sherard, J.L. 1973. "Embankment Dam Cracking, *Embankment-Dam Engineering, Casagrande Volume*, Wiley, Malabar, Florida, pp. 271-353.
- Sherard, J.L. 1953. "Influence of Soil Properties and Construction Methods on the Performance of Homogeneous Earth Dams," Technical Memorandum No. 645. Bureau of Reclamation, Denver, Colorado.
- Sherard, J.L., L.P. Dunnigan, J.R. Talbot. 1984. "Basic Properties of Sand and Gravel Filters," *ASCE Journal of Geotechnical Engineering*, American Society of Civil Engineers, Vol. 110, No. 6, pp. 684-700.
- Skempton, A.W. and J.M. Brogan. 1994. "Experiments on Piping in Sandy Gravels, *Géotechnique*, Vol. 44, No. 3, pp. 449-460.

Chapter D-6 Internal Erosion Risks for Embankments and Foundations

- Solvik, Ø. 1991. “Through Flow and Stability Problems in Rockfill Dams Exposed to Exceptional Loads,” Proceedings of the 17th ICOLD Congress on Large Dams. Vienna. International Commission on Large Dams, Paris.
- Terzaghi, K. 1943. *Theoretical Soil Mechanics*, Wiley, New York, New York.
- Terzaghi, K. 1939. “Soil Mechanics: A New Chapter in Engineering Science,” *Journal of the Institution of Civil Engineers*, United Kingdom, Vol. 12, No. 7, pp. 106–141.
- Terzaghi, K., R.B. Peck, and G Mesri. 1996. *Soil Mechanics in Engineering Practice*, Third Edition, Wiley, New York, New York.
- Townsend, F. and J.M. Shiau. 1986. *Analytical and Experimental Evaluation of Piping and Filter Design for Sands*, Gainesville, Florida.
- United States Army Corps of Engineers (USACE). 2000. *Design and Construction of Levees*, USACE Engineering Manual 1110-2-1913. USACE, Washington, DC.
- _____. 2005. *Seepage Analysis and Control*, USACE Engineering Manual 1110-2-1901, Change 2. USACE Washington, D.C.
- _____. 2014. “Design of Hydraulic Steel Structures,” USACE Engineering Technical Letter 1110-2-561. June 2014.
- van Beek, V.M., A. Koelewijn, G. Kruse, H. Sellmeijer, and F. Barends. 2008. “Piping Phenomena in Heterogeneous Sands – Experiments and Simulations,” Proceedings of the International Conference on Scour and Erosion, Tokyo, Japan, pp. 453-459.
- van Beek, V.M., M. Van, Knoeff, J.G., H.T.J. de Bruijn, and J.B. Sellmeijer. 2009. *Influence of Sand Characteristics on the Piping Process – Small-Scale Experiments*.
- van Beek, V.M., H. Knoeff, H. Sellmeijer. 2011. “Observations on the Process of Backward Erosion Piping in Small-, Medium-, and Full-Scale Experiments,” *European Journal of Environmental and Civil Engineering*, Vol. 15, No. 8, pp. 1115-1137.
- van Beek, V.M., H.M. Van Essen, K. Vandenboer, and A. Bezuijen. 2015. “Developments in Modelling of Backward Erosion Piping,” *Géotechnique*, Vol. 65, No. 9. pp. 740-754.

Chapter D-6 Internal Erosion Risks for Embankments and Foundations

- van Rhee, C. and A. Bezuijen. 1992. "Influence of Seepage on Stability of Sandy Slope," *ASCE Journal of Geotechnical Engineering*, American Society of Civil Engineers, Vol. 118, No. 8, pp. 1236-1240.
- Von Thun, J.L. 1996. "Understanding Seepage and Piping Failure: The No. 1 Dam Safety Problem in the West," Association of State Dam Safety Officials Western Regional Conference, Lake Tahoe, Nevada.
- Vuola P., J.M. Konrad, and M. Bartsch. 2007. Effects of Frost and Thaw on Dams. Assessment of the Risk of Internal Erosion of Water Retaining Structures: Dams, Dykes and Levees, Intermediate Report of the European Working Group of International Commission on Large Dams.
- Wan, C.F., and R. Fell. 2002. Investigation of Internal Erosion and Piping of Soils in Embankment Dams by the Slot Erosion Test and the Hole Erosion Test, UNICIV Report No. R-412, University of New South Wales, Sydney, Australia.
- _____. 2004a. Experimental Investigation of Internal Instability of Soils in Embankment Dams and Their Foundations, UniCiv Report No. R-429, University of New South Wales, Sydney, Australia.
- _____. 2004b. "Investigation of Rate of Erosion of Soils in Embankment Dams," *ASCE Journal of Geotechnical and Geoenvironmental Engineering*, American Society of Civil Engineers, Vol. 130, No. 4, pp. 373-380.
- _____. 2008. "Assessing the Potential of Internal Instability and Suffusion in Embankment Dams and their Foundations," *ASCE Journal of Geotechnical and Environmental Engineering*, American Society of Civil Engineers, Vol. 134, No. 3, pp. 401-407.
- Weijers, J.B.A. and J.B. Sellmeijer. 1993. A New Model to Deal with the Piping Mechanism, Filters in Geotechnical and Hydraulic Engineering (Proceedings, 1st International Conference "Geo-Filters"), Balkema, Rotterdam, pp. 349-376.
- White, C.M. 1940. "The Equilibrium of Grains on the Bed of a Stream," *Proceedings of the Royal Society*, London, Vol. 174A, No. 1940, pp. 322-338.
- Ziems, J. 1969. "Beitrag zur Kontakterosion Nichtbindiger Erdstoffe," Ph.D Thesis, TU Dresden, Saxony, Germany.

D-6.10.1 Other Resources

- Hanson, G.J. 1990. "Surface Erodibility of Earthen Channels at High Stresses, Part II –Developing an In-Situ Testing Device," *American Society of Agricultural Engineers*, Vol. 33, No. 1, pp. 132-137.
- Li, M. 2008. "Seepage Induced Instability in Widely Graded Soils," Ph.D. Thesis, University of British Columbia, Vancouver, Canada.
- Li, Z. 1985. "Pivoting Angles of Gravel with Applications in Sediment Threshold Studies," Master of Science Thesis, Oregon State University, Corvallis, Oregon.
- O'Leary, T., N. Vroman, C. Williams, and M. Pabst. 2013. "Critical Horizontal Seepage Gradients: Correction," *Journal of Dam Safety*, Association of State Dam Safety Officials, Lexington, Kentucky, Vol. 11, No. 4.
- _____. 2013. "Critical Horizontal Seepage Gradients," *Journal of Dam Safety*, Association of State Dam Safety Officials, Lexington, Kentucky, Vol. 11, No. 3, pp. 33-42.
- Olivier, H., A.L. Little, J.D. Williams, V.G. Palnitkar, J.D. Lawson, T. Broughton, D.J. Knight, R.A. Sutherland, L.E. Prosser, D.H. Saunders, P.A.A. Back, A.K. Parkin, P. Curtis, J.K. Wilkins, and G Avramov. 1967. "Discussion: Through and Overflow Rockfill Dams – New Design Techniques," *Proceedings, Institution of Civil Engineers*, 37(4):855-888.
- Pells, S. and R. Fell. 2003. "Damage and Cracking of Embankment Dams by Earthquake and the Implications for Internal Erosion and Piping," Proceedings of the 21st Internal Congress on Large Dams, Montreal. ICOLD, Paris Q83-R17, International Commission on Large Dams, Paris.
- van Beek, V.M., A. Bezuijen, and F.M. Schenkeveld. 2012. "Piping in Loose Sands – the Importance of Geometrical Fixity of Grains," *Eurofuge 2012*, Delft, Netherlands.
- van Beek, V.M., H.T.J. Bruijin, J.G. Knoeff, A. Bezuijen, U. Förster. 2010. "Levee Failure Due to Piping: A Full-Scale Experiment." *American Society of Civil Engineers Geotechnical Special Publication No. 210*, Proceedings of the International Conference on Scour and Erosion, San Francisco, California, ASCE, pp. 283-292.
- van Beek, V.M., J.G. Knoeff, J. Rietdijk, J.B. Sellmeijer, and J. Lopez de La Cruz. 2010. "Influence of Sand and Scale on the Piping Process – Experiments and Multivariate Analysis," Proceedings of the 7th International Conference on Physical Modeling in Modeling in Geotechnics, Zurich, pp. 1221-1226.

Chapter D-6 Internal Erosion Risks for Embankments and Foundations

- van Beek, V.M., Q. Yao, M. Van, and F. Barends. 2012. "Validation of Sellmeijer's Model for Backward Erosion Piping under Dikes on Multiple sand layers." Proceedings of the 6th International Conference on Scour and Erosion, Paris, pp. 543-550.
- Von Thun, J.L. 1999. "Background on Philosophy and Technical Rationale for Reclamation's Dam Safety Public Protection Guidelines," Memorandum to Chuck Hennig and Risk Cadre Members, Bureau of Reclamation, Technical Service Center, Denver, Colorado.
- Wan, C.F. 2006. "Experimental Investigation of piping Erosion and Suffusion of Soils in Embankment Dams and Their Foundations," Ph.D. Thesis, University of New South Wales, Sydney, Australia.
- Yalin, S. and E. Karahan. 1979. "Inception of Sediment Transport," *ASCE Journal of the Hydraulics Division*, American Society of Civil Engineers, Vol. 105, No. HY11, pp. 1433-1443.

APPENDIX D-6-A

Large Dam Failure Statistics

Appendix D-6-A Large Dam Failure Statistics

**Table D-6-A-1.—Overall Statistics of Embankment Dam Failures
(adapted from Fell et al. 1998, 2000)**

No. of Cases		% of Failures (if Known)		Average Probability of Failure	
All Failures	Failures in Operation	All Failures	Failures in Operation	All Failures	Failures in Operation
Internal Erosion through the Embankment					
39	38	30	33	3.5E-03	3.5E-03
Internal Erosion through the Foundation					
19	18	15	15	1.5E-03	1.5E-03
Internal Erosion from the Embankment into the Foundation					
2	2	1.5	1.5	2.0E-04	2.0E-04

**Table D-6-A-2.—Historical Frequencies of Failures and Accidents
(adapted from Fell et al. 1998, 2000)**

Case	Total	In Embankment	Around Conduits and Adjacent to Walls
Internal erosion failures	36	19	17
Internal erosion accidents	75	52	23
Seepage accidents with no detected erosion	36	30	6
Total number of failures and accidents	146	101	46
Population of dams	11,192	11,192	5,596
Historical frequency for failures and accidents	0.013	0.009	0.0082
Proportion of failures and accidents on first-filling	36%		
Proportion of failures and accidents after first-filling	64%		
Historical frequency for first-filling		0.0032	0.0030
Historical frequency after first-filling		0.0058	0.0052
Historical annual frequency after first-filling		2.2E-04	2.0E-04

Appendix D-6-A Large Dam Failure Statistics

Table D-6-A-3.—Time of Incident for Internal Erosion through the Embankment (adapted from Fell et al. 1998, 2000)

Time of Incident	No. of Cases		% of Cases (if Known)	
	Failures	Accidents	Failures	Accidents
During construction	1	0	2	0
During first-filling	24	26	48	26
After first-filling and during first 5 years	7	13	14	13
After first 5 years	18	60	36	61
Unknown	1	3	–	–
Total	51	102	100	100

Table D-6-A-4.—Time of Incident for Internal Erosion through the Foundation (adapted from Fell et al. 1998, 2000)

Time of Incident	No. of Cases		% of Cases (if Known)	
	Failures	Accidents	Failures	Accidents
During construction	1	0	5	0
During first-filling	4	23	20	30
After first-filling and during first 5 years	10	19	50	24
After first 5 years	5	36	25	46
Unknown	1	7	–	–
Total	21	85	100	100

Table D-6-A-5.—Incidents of Cracking and Hydraulic Fracturing (adapted from Fell et al. 2008)

Cracking Mechanism	No. of Cases	Percentage
Differential settlement, cross-valley	20	35
Differential settlement, cross-section	6	11
Differential settlement, foundation	4	7
Differential settlement, embankment staging	0	0
Desiccation cracking	3	5
Closure section	3	5
Total	36	63

Appendix D-6-A Large Dam Failure Statistics

**Table D-6-A-6.—Incidents of Poorly Compacted and High Permeability Zones
(adapted from Fell et al. 2008)**

Location	No. of Cases	Percentage
At the foundation-embankment interface	5	9
In the embankment	16	28
Total	21	37

APPENDIX D-6-B

Historical Frequencies

Reclamation researched the frequency of internal erosion incidents for their portfolio of over 230 high and significant hazard embankment dams. A summary of Reclamation's research and experience relative to this topic is provided in this appendix.

Use of Historical Frequencies

Estimating the probability of an internal erosion failure is very difficult and lacks deterministic approaches. Thus, the use of similar case histories provides some degree of "ground truth" or empiricism/precedence to the evaluation. Laboratory testing of small specimens to develop erosion properties and similar data may not be representative of the weak link or true condition in the spatially large embankment-foundation system. Similarly, seepage models may not be representative of the key hydraulic conditions that would drive the development of an internal erosion potential failure modes along a long seepage path through variable materials. It may not be a wise use of limited funds to spend significant monies in an effort to estimate a probability that is arguably no more than an index value.

Estimated historic rates of internal erosion initiation can provide risk teams with a relative range or average value for various types of internal erosion (i.e., a "starting" or "anchoring" point). Reclamation in the past has typically based the likelihood of this event on the documented historical rate of internal erosion failures and incidents (specifically work by the University of New South Wales (UNSW), and adjusted upward or downward based on site specific factors. Most recently, reviews of Reclamation internal erosion incidents have been made (Engemoen and Redlinger 2009; Engemoen 2011, 2017). The following is a discussion from those studies:

- Reviews of Reclamation internal erosion incidents indicate there have been a total of 97 known incidents and one failure. Internal erosion incidents have occurred throughout the history of Reclamation embankments, and sometimes multiple instances at the same dam. The total number of dams that have experienced incidents is 60, or about 1 in every 4 Reclamation embankments.
- *These incidents are not limited to first filling but can occur at any time in a dam's life.* About 30 percent of Reclamation incidents have occurred during the first five years of reservoir operation, and 70 percent of all incidents have occurred after more than five years of successful operation.

Appendix D-6-B Historical Frequencies

- The incidents have also not been limited to older or deteriorated dams; newer dams have also had incidents. Approximately half of the incidents occurred in dams that were more than 25 years old, and the other half in dams that were less than 25 years old.
- Each incident was classified into one of five categories: 1) internal erosion through the embankment; 2) internal erosion through the foundation; 3) internal erosion of embankment into foundation; 4) internal erosion into or along a conduit; and 5) internal erosion into a drain.
- In addition, each incident was also classified into one of four internal erosion mechanisms: 1) backward erosion piping; 2) internal migration (formerly called progressive erosion); 3) scour; and 4) suffusion/suffosion (related to internal instability). Admittedly, the assignment of an internal erosion mechanism to a past incident requires a lot of judgment – in many cases a definitive understanding of just what type of process or mechanism is not clear. Furthermore, some incidents may well involve a combination of mechanisms.
- For both classification exercises, the evidence for developing internal erosion is also shown, as either “excessive seepage” or “particle transport.” The use of particle transport was limited to those cases where clear evidence of internal erosion was noted, such as the presence of sinkholes, voids, sand boils that were moving soils, or turbid seepage water. Of the total 97 incidents/failures at Reclamation embankments, there have been a total of 66 cases where particle transport was observed.
- Tables D-6-B-1 and B-2 portray the incidents in two different ways; first by category (location), and secondly by type of mechanism.

The following observations from table D-6-B-1 are of note:

- Approximately 45 percent of the tabulated internal erosion incidents have involved internal erosion through the foundation, likely due to the significant number of Reclamation dams without a fully penetrating cutoff over their entire length, the pervious nature of the foundation materials leading to significant seepage, and the presence of erodible soils in the foundation.
- Of the 44 foundation incidents, 10 involved glacial soils, and 5 were attributed to bedrock seepage. The remainder, or majority, of the incidents were in soil foundations comprised of alluvium, colluvium, eolian, or landslide deposits.

Appendix D-6-B Historical Frequencies

Table D-6-B-1.—Category of Internal Erosion Incidents at Reclamation Embankments

Category of Internal Erosion	Incidents/Failures with Definitive Particle Transport	Incidents with Excessive Seepage and Perhaps Sand Boils	All Incidents and Failures
Embankment only	5	4	9
Foundation only	28	16	44
Embankment into foundation	7	11	18
Into/along conduit	8	0	8
Into drain	18	0	18
Total	66	31	97

Table D-6-B-2.—Postulated Internal Erosion Failure Mechanisms Involved in Incident

Category of Internal Erosion	Incidents/Failures with Definitive Particle Transport	Incidents with Excessive Seepage and Perhaps Sand Boils	All Incidents and Failures
Backward erosion piping	16	6	22
Internal migration	24	0	24
Scour	17	20	37
Suffusion/suffosion	9	5	14
Total	66	31	97

- When considering both internal erosion through the foundation and internal erosion from embankment into foundation, the foundation has played a role in at least two-thirds of all Reclamation incidents.
- The relatively low frequency of internal erosion through the embankment incidents might be explained by Reclamation’s use of wide cores (long seepage path) often flanked by shells of sands/gravels/cobbles (providing some filtering capability). In addition, nearly 60 percent of Reclamation embankment cores are comprised of plastic soils ($PI \geq 7$) and another 7 percent feature an impermeable reservoir liner or cutoff wall.

The relatively high number of internal erosion into drain incidents may be due to decades of relatively poor design details for drains (open jointed pipe, brittle pipe materials, coarse gravel envelopes, and thin filters).

Appendix D-6-B Historical Frequencies

The following observations from table D-6-B-2 are of note:

- One-half of all incidents are suspected to have involved internal migration or backward erosion piping, with each mechanism accounting for about a quarter of the total.
- Scour is believed to account for approximately 40 percent of the total incidents.
- Suffusion/suffosion is believed to account for about 1/7 of the total incidents.
- Of these, half involved glacial soils.
- *The vast majority (~80%) of incidents involved cohesionless or low plasticity soils ($PI < 7$).*

Table D-6-B-3 portrays the age of the dam (or modifications to a dam) at the time of each incidents.

Table D-6-B-3.—Age of Dam at Incident and Mechanism Type

Dam Age at Incident	No. of Piping Incidents	No. of Internal Migration Incidents	No. of Scour Incidents	No. of Suffusion-Suffosion Incidents	Total No. of Incidents
≤ 5 years	6	5	14	4	29
6-15 years	1	2	5	0	8
16–25 years	5	5	2	0	12
26-35 years	2	1	3	1	7
36-45 years	3	2	3	1	9
46-55 years	0	3	2	3	8
56-65 years	2	1	3	0	6
66-75 years	0	3	4	2	9
76-85 years	2	2	0	2	6
> 85 years	1	0	1	1	3
Totals	22	24	37	14	97

Appendix D-6-B Historical Frequencies

The following observations from table D-6-B-3 are of note:

- Incidents are much more likely to occur in the first five years of reservoir operation (which includes first filling of the reservoir).
- However, incidents continue to occur beyond 5 years, with little significant decline in rate of incidents after 5 years.
- Most (60 to 75 percent) of the incidents involving internal migration, scour, and suffusion/suffosion occur in the first 25 years of operational history.
- However, piping incidents tend to occur throughout the operational history; i.e., they are as likely to occur late as early.

Influence of Reservoir Level at Time of Incident

There is a widely held belief that most internal erosion incidents in embankments or foundations initiate at threshold reservoir levels that create sufficient hydraulic gradients or velocities to begin eroding susceptible soil particles. Thus, practitioners are likely to be more concerned about internal erosion at high reservoir levels. In fact, based on Reclamation incidents, internal erosion can manifest at varying reservoir levels.

A special condition involving reservoir levels involves the initial filling of the reservoir. Initial filling refers to the first time, shortly after completion of construction, that the reservoir is filled to its normal operational level (frequently the top of active conservation capacity at Reclamation reservoirs). Other studies have pointed out the frequency at which embankments experience internal erosion incidents during first filling. At Reclamation, 23 of the 97 incidents, or about 24 percent, occurred during initial filling of the pool. This points out the need for careful surveillance during initial reservoir filling (or re-filling after a modification).

However, at Reclamation, 74 incidents occurred during operations after first filling. Table D-6-B-4 portrays the level of the reservoir at the time of these 74 observed incidents at Reclamation embankments.

Appendix D-6-B Historical Frequencies

Table D-6-B-4.—Reservoir Level at Time of Incident (for embankments after first filling)

Reservoir Level	Number of Incidents	Percentage of Incidents
Above normal operational level	11	15 %
At normal operational level *	52	70 %
Below normal operational level	11	15 %
TOTAL	74	

*Note: At normal operational level typically means within 2 feet of the normal annual high pool.

The following observations from table D-6-B-4 are of note:

- At Reclamation embankments that successfully completed initial reservoir filling and were in normal operational status, **approximately 85 percent of internal incidents were observed at reservoir levels at or below normal levels.**
- Only 15 percent of internal erosion incidents after first filling were observed during higher than *normal* reservoir levels. At most Reclamation facilities, “*normal*” levels refer to the top of active conservation or joint use that the pool routinely reaches in most years. At a few facilities where the top of active is rarely reached, normal was assumed to be the typical upper levels reached in the past.
- Some of the incidents in this study clearly suggest that internal erosion had been slowly progressing for years or even decades. Reclamation believes that many internal erosion processes may take years to progress to the point of showing indications of distress or obvious particle transport. Thus, the reservoir level at the time of the incident may not reflect the key hydraulic head responsible for the initiation of internal erosion. **It is possible that internal erosion may occur during the several-week period of typical high reservoir levels at Reclamation facilities, and then stop for the season. In other words, internal erosion can be an episodic event that progresses to a limited extent only at normal high pools, year after year.**

Development of Base Rate Frequencies of Initiation of Internal Erosion

An estimate of the rate of initiation of internal erosion at a typical Reclamation embankment dam can be obtained by dividing the number of incidents and failures by the number of dam-years of operation. Since our current inventory of

Appendix D-6-B Historical Frequencies

embankment dams contains all dams that have experienced a first filling (the youngest dam is 6 years old as of 2016), of specific interest are incidents at dams that have survived first filling. (For a dam safety evaluation of a new dam, these base rate frequencies reflecting the likelihood of initiation would not be appropriate and could be much higher. Furthermore, when considering the likelihood of initiation of internal erosion at flood levels, these base rate frequencies should be adjusted upward based on considerations such as potential for flaws in upper portion of the dam, amount of increased gradient expected, etc.)

When considering the potential for incidents after first filling, there seems to be a significant break at an age of 5 years as shown in table D-6-B-5. Thus, the number of incidents after 5 years of operation will be considered in developing base rate frequencies for dams that have survived first filling. Furthermore, since Reclamation is particularly concerned with the risk of internal erosion at normal operation levels, another filter will be to consider only those incidents that occurred at or below normal reservoir levels. From this Reclamation incident database, there are 58 incidents that occurred at or below normal pool levels at dams that had at least 5 years of reservoir operation. These applicable incidents are summarized in table D-6-B-5.

Table D-6-B-5.—Number of Incidents of Internal Erosion at Reclamation Embankment Dams (after 5 years of operation and at or below normal pool level)

	Backward Piping	Internal Migration	Scour	Suffusion/Suffosion	TOTALS
Embankment	0	1	5	1	7
Foundation	5	5	7	6	23
Emb into Fnd	0	0	5	0	5
Into/along Conduit	2	4	1	0	7
Into Drain	5	9	0	2	16
TOTALS	12	19	18	9	58

The total number of operational dam-years was obtained by identifying each of the 233 Reclamation embankments considered in this study, determining their present age (to year 2016), and summing all ages. In this manner, the number of dam-years of operation at Reclamation facilities was calculated to be 14,611. For all categories not involving the foundation only or into/along a conduit, this number of dam-years is considered to represent the operational history of the Reclamation embankments in the study.

However, adjustments are needed when considering internal erosion in the foundation and into/along conduits. As the incident database reflects, internal

Appendix D-6-B Historical Frequencies

erosion through the foundation only is likely limited to embankments with partially penetrating cutoffs (with only 3 exceptions involving unusual bedrock/foundation conditions). Therefore, the appropriate operational history to use would be the number of dam-years associated with those Reclamation embankments featuring partial cutoffs – this value was computed to be 7,191 dam-years. Similarly, internal erosion into/along the conduits is only a viable scenario (with very rare exceptions) for those embankments that feature a penetrating conduit within the embankment. The number of dam-years associated with these specific embankments total 7,858.

Using these values of dam-years of operation and the number of incidents (under normal operations and after 5 years of operation) identified by the study, the following tables D-6-B-6 and -7 present the estimated historical rate at which erosion has initiated (and continued to progress to at least some degree).

Table D-6-B-6.—Historical Rate of Initiation of Internal Erosion at Reclamation Embankments Based on Category

Internal Erosion Category	Estimated Historical Rate of Erosion Initiation*	
	Incidents/Failures with Definitive Particle Transport	All Incidents/Failures
Embankment only	3.4×10^{-4}	4.8×10^{-4}
Foundation only	2.2×10^{-3}	3.2×10^{-3}
Embankment into foundation	1.4×10^{-4}	3.4×10^{-4}
Into/Along conduit	8.9×10^{-4}	8.9×10^{-4}
Into drain	1.1×10^{-3}	1.1×10^{-3}
TOTAL	4.7×10^{-3}	6.0×10^{-3}

*Note: See later discussion of whether these data include more than just "initiation."

Table D-6-B-7.—Historical Rate of Initiation of Internal Erosion at Reclamation Embankments Based on Mechanism

Internal Erosion Mechanism	Estimated Historical Rate of Erosion Initiation*	
	Incidents/Failures with Definitive Particle Transport	All Incidents/Failures
Backward erosion piping	1.0×10^{-3}	1.3×10^{-3}
Internal migration	1.9×10^{-3}	1.9×10^{-3}
Scour	1.2×10^{-3}	1.8×10^{-3}
Suffusion/suffosion	6.2×10^{-4}	1.0×10^{-3}
TOTAL	4.7×10^{-3}	6.0×10^{-3}

*Note: See later discussion of whether these data include more than just "initiation."

Appendix D-6-B Historical Frequencies

It is easy to question whether this review of past internal erosion incidents is a reasonable portrayal of performance at Reclamation embankments. Another way to consider this frequency question might be to note that it is not unusual, on average, to see 1 or maybe even 2 new “incidents” of unusual seepage or piezometric behavior, new sand boils, or new sinkholes each year within the Reclamation inventory of embankment dams. Assuming 1.5 incidents per year with 233 embankments equates to an annual frequency of 6.4×10^{-3} . This alternate approach to estimating a base rate frequency of the initiation of internal erosion happens to be similar to the summary value obtained from the incident study – although far from definitive, this does support a measure of confidence in the reasonableness of these frequency data.

Rather than directly use the values reflected in these tables, it is recognized that additional adjustments may better reflect the ranges of potential “best estimate” values given the variables and uncertainties involved with categorizing internal erosion events. One key uncertainty deals with whether the historical base rate of incidents portrayed above reflects more than just the “initiation” phase of the internal erosion process. In other words, initiation may have occurred in more Reclamation embankments than these catalogued because the process never “progressed” far enough to manifest symptoms like those detected or observed in the 97 cases.

It is difficult to estimate an additional number of dams where internal erosion may have initiated but did not continue or progress, and thus remained undetected. The original UNSW study of world-wide dams (Foster et al. 1998) assumed the number of “unreported” incidents of initiation was probably in the range of 2 to 10 times the number of reported incidents. Given Reclamation’s reporting and documentation capabilities, it would seem likely that the lower portion of this range would be more applicable. In addition, there are some cases where the true source of the seepage and any signs of particle transport could not be conclusively tied to the reservoir. This is especially true in the cases of internal erosion through foundation and into drains, as other seepage sources (hillside, tailwater, etc.) may have provided the driving hydraulic head.

Furthermore, rather than specifying a single value, it appears to make more sense to suggest a range of **best estimate** values. The term “best estimate” is used since the true range of initiation of internal erosion probably spans several orders of magnitude. The lower end of the **best estimate** range is based on applying a multiplier of 1.25 to the observed 46 cases of definite particle transport, which assumes 25 percent more cases of definitive particle transport may have occurred and not noticed or reported. It seems rather unlikely that definitive evidence would not have been observed; thus a relatively small multiplier. (However, this multiplier was not applied to “foundation only” and “into drain” categories due to the belief that some incidents may have been attributed to seepage sources other than the reservoir.) The upper end of the best estimate range is based on a doubling of all 58 reported incidents, including the 12 that did not manifest any

Appendix D-6-B Historical Frequencies

particle transport. Thus, the upper range values assume that only about 40 percent of all cases of definitive initiation of internal erosion have actually been observed and documented within Reclamation.

These adjusted values shown in tables D-6-B-8 and -9 are proposed as “starting points” or an empirical reference point for considering the probability of the initiation of internal erosion for Reclamation dams (or in an inventory of dams similar to Reclamation’s). It should be noted that this inventory includes approximately 200 dams constructed prior to the failure of Teton Dam without well designed filters. These tables are considered “summary” tables in that they provide a broad view of overall base rate frequencies.

Table D-6-B-8.—Proposed *Best Estimate* Values of Annual Probabilities of Initiation of Internal Erosion by Category

Type of Internal Erosion	Range of Initiation Probability
Embankment only	4×10^{-4} to 1×10^{-3}
Foundation only*	2×10^{-3} to 6×10^{-3}
Embankment into foundation	2×10^{-4} to 7×10^{-4}
Into/Along conduit**	1×10^{-3} to 2×10^{-3}
Into drain*	1×10^{-3} to 2×10^{-3}

*Note: “Foundation only” and “Into drain” lower values were not adjusted by the 1.25 multiplier given the belief that some incidents may have been attributed to seepage sources other than the reservoir.

Table D-6-B-9.—Proposed *Best Estimate* Values of Annual Probabilities of Initiation of Internal Erosion by Mechanism

Type of Internal Erosion	Range of Initiation Probability
Backward erosion piping	1×10^{-3} to 3×10^{-3}
Internal migration	2×10^{-3} to 4×10^{-3}
Scour	2×10^{-3} to 4×10^{-3}
Suffusion/suffosion	8×10^{-4} to 2×10^{-3}

Appendix D-6-B Historical Frequencies

Considerations for Usage of the Base Rate Frequency tables:

1. These ranges are considered to be “**best estimates**” – *not the reasonable low and reasonable high*. Higher or lower estimates of initiation probability may be appropriate if conditions at the dam being evaluated are better or worse than the “average” condition at a Reclamation dam. For example, dams with very low hydraulic gradients and minimal seepage may lead to lower estimates of initiation, while dams with appreciable seepage or a history of concerns may warrant higher estimates.
2. The incidents used to develop these values were limited to only Reclamation embankment dams, so use on embankments designed/constructed by others should consider how well those dams compare to Reclamation practices.
3. A total of 80 percent of the incidents featured soils with no or low plasticity (i.e., $PI < 7$). If postulated failure modes involve low plasticity soils, there is no need to consider higher estimates. However, lower initiation rates may be considered with more plastic soils.
4. The portrayed base rate frequencies have been developed for dams with more than 5 years of operational history and operating at normal reservoir levels. Thus, when evaluating new dams, consideration should be given to using somewhat higher values of initiation probability. Similarly, when estimating hydrologic risks, higher values of initiation probability would be expected when a dam is exposed to future higher reservoir levels.
5. ***Simply referring to the tabulated best estimates from Reclamation’s history of incidents is not sufficient in evaluating the probability for erosion to initiate.*** Instead, site conditions must be considered in order to determine whether there are features, conditions, or behaviors present at a given site that will influence the potential for erosion to initiate. Comprehensive tables have been developed that offer a number of considerations that would affect the likelihood of initiation at a given site. There are separate tables for each category of internal erosion. Any estimate of initiation should consider the factors in the 11x17 tables in “Appendix D-6-J, Tables of More and Less Likely Factors for Different Categories of Internal Erosion.”

APPENDIX D-6-C

Concentrated Leak Erosion

Given a crack or gap (i.e., flaw) exists, the initiation of concentrated leak erosion depends on the depth or location of cracking relative to the headwater level and the forces imposed on the sides of the crack by water flowing through it. The resistance to initiation of concentrated leak erosion is characterized by the critical shear stress (“Chapter D-1, Erosion of Rock and Soil”). To help assess the likelihood of initiation of concentrated leak erosion in a crack or gap, the hydraulic shear stress in the crack for the headwater level under consideration can be compared to the critical shear stress which will initiate erosion for the soil in the core of the embankment at the degree of saturation of the soil on the sides of the crack. Further details are provided in this appendix.

Estimation of crack widths and depths involves a lot of uncertainty. ICOLD (2013) provides some examples of likely crack depths and widths due to cross-valley differential settlement or differential settlement in the foundation. These estimates are based primarily on the methods described in Fell et al. (2008), which includes methods for transverse cracking due to differential settlement, frost action, and desiccation, as well as hydraulic fracture. If a crack forms during construction, it may be masked by lifts placed near the crest after most of the deformation is complete, which may not propagate a crack upward, at least not to the same openness.

Common Situations Where Concentrated Leaks May Occur

Figure D-6-C-1 through D-6-C-19 show typical locations where concentrated leaks occur.

Appendix D-6-C Concentrated Leak Erosion

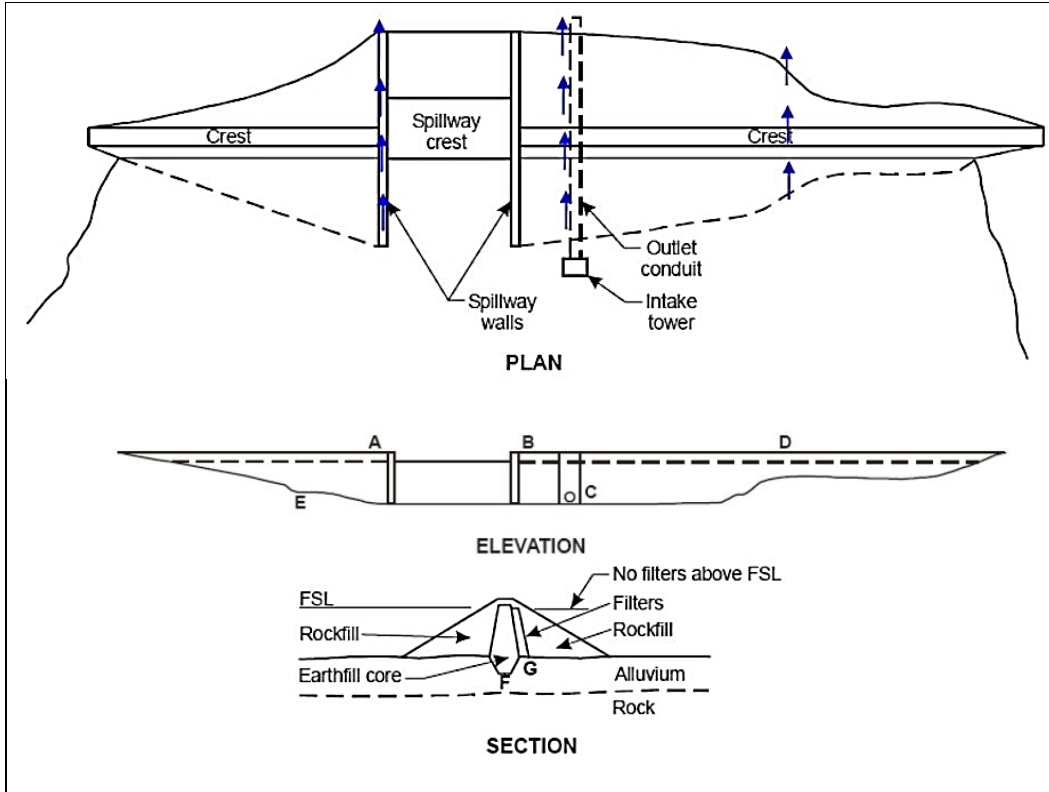

Figure D-6-C-1.—Potential failure paths (Fell et al. 2008).

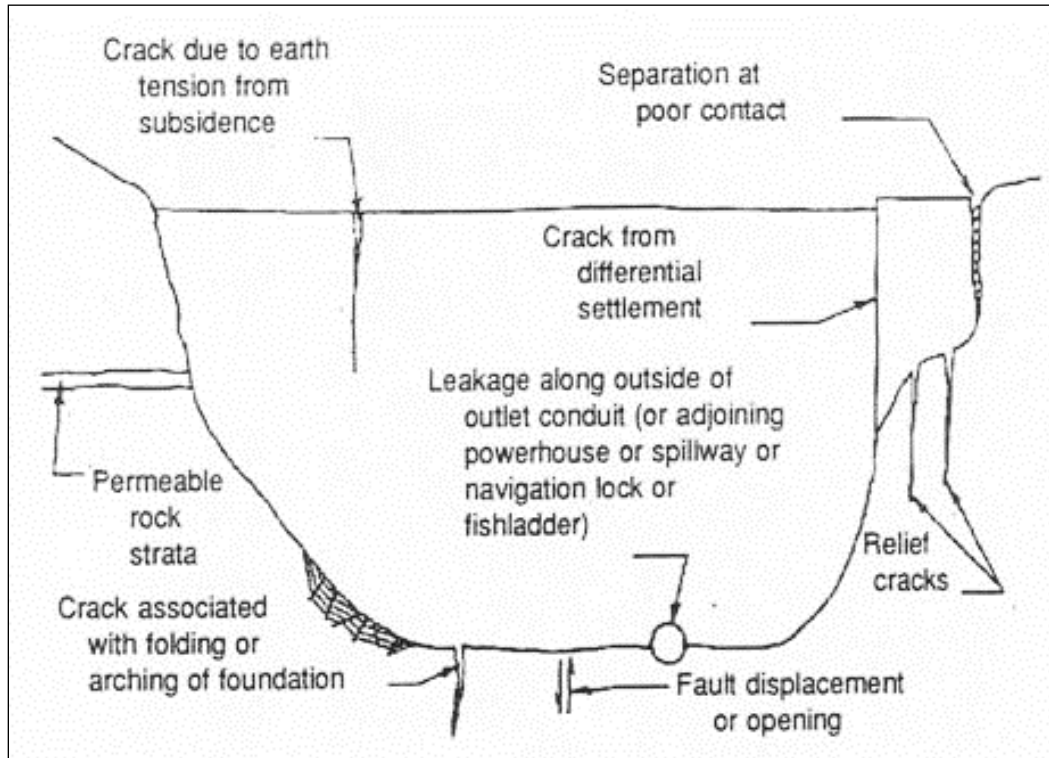

Figure D-6-C-2.—Potential failure paths (unknown source).

Appendix D-6-C Concentrated Leak Erosion

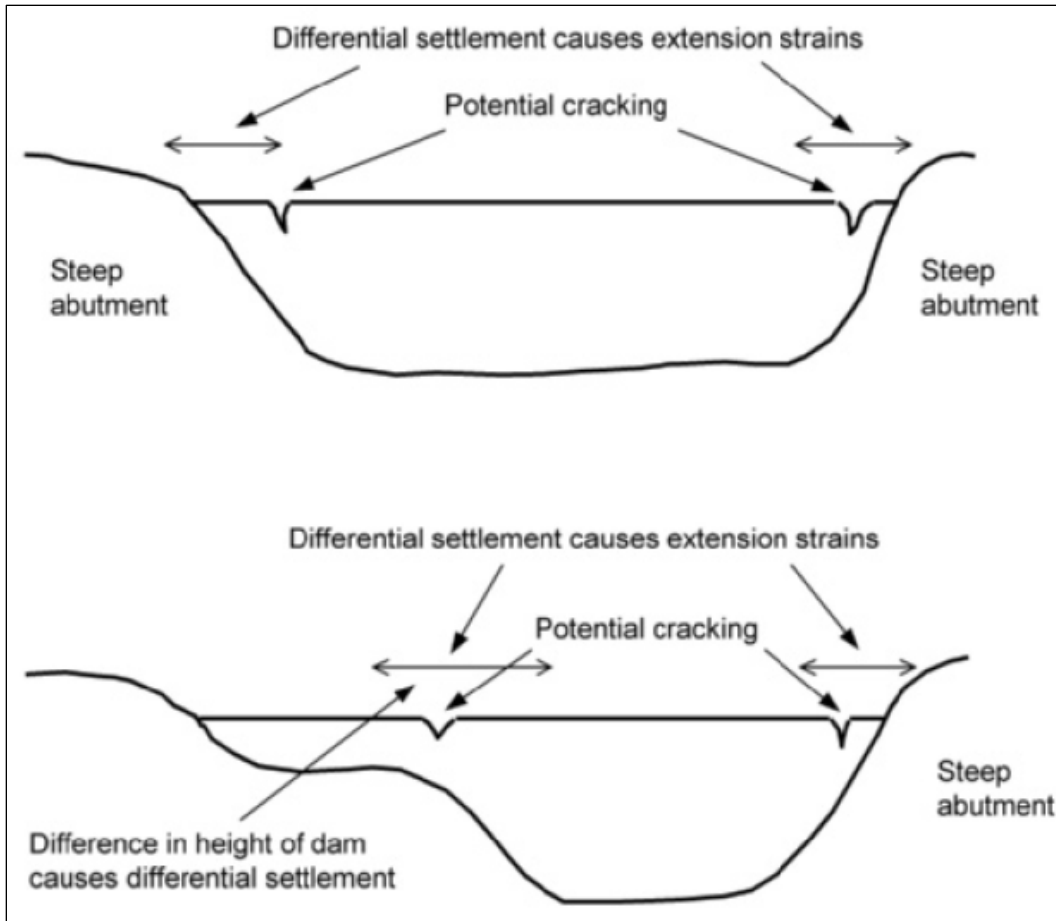

Figure D-6-C-3.—Cracking and hydraulic fracture due to cross-valley differential settlement of the core (Fell et al. 2014).

Appendix D-6-C Concentrated Leak Erosion

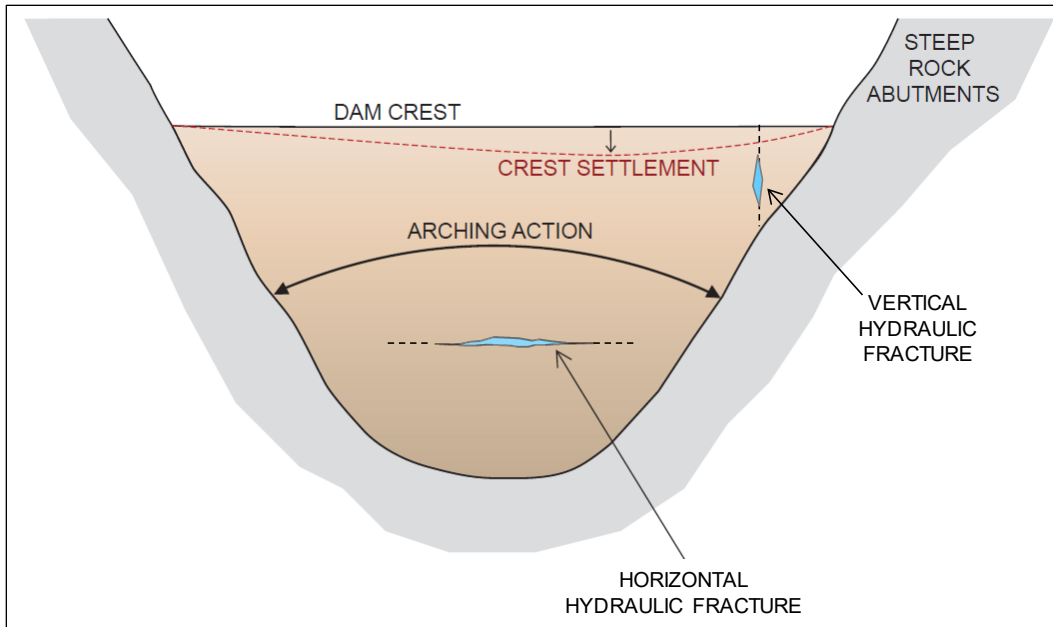

Figure D-6-C-4.—Cracking and hydraulic fracture due to cross-valley arching and steep abutment slopes (courtesy of Mark Foster).

Appendix D-6-C Concentrated Leak Erosion

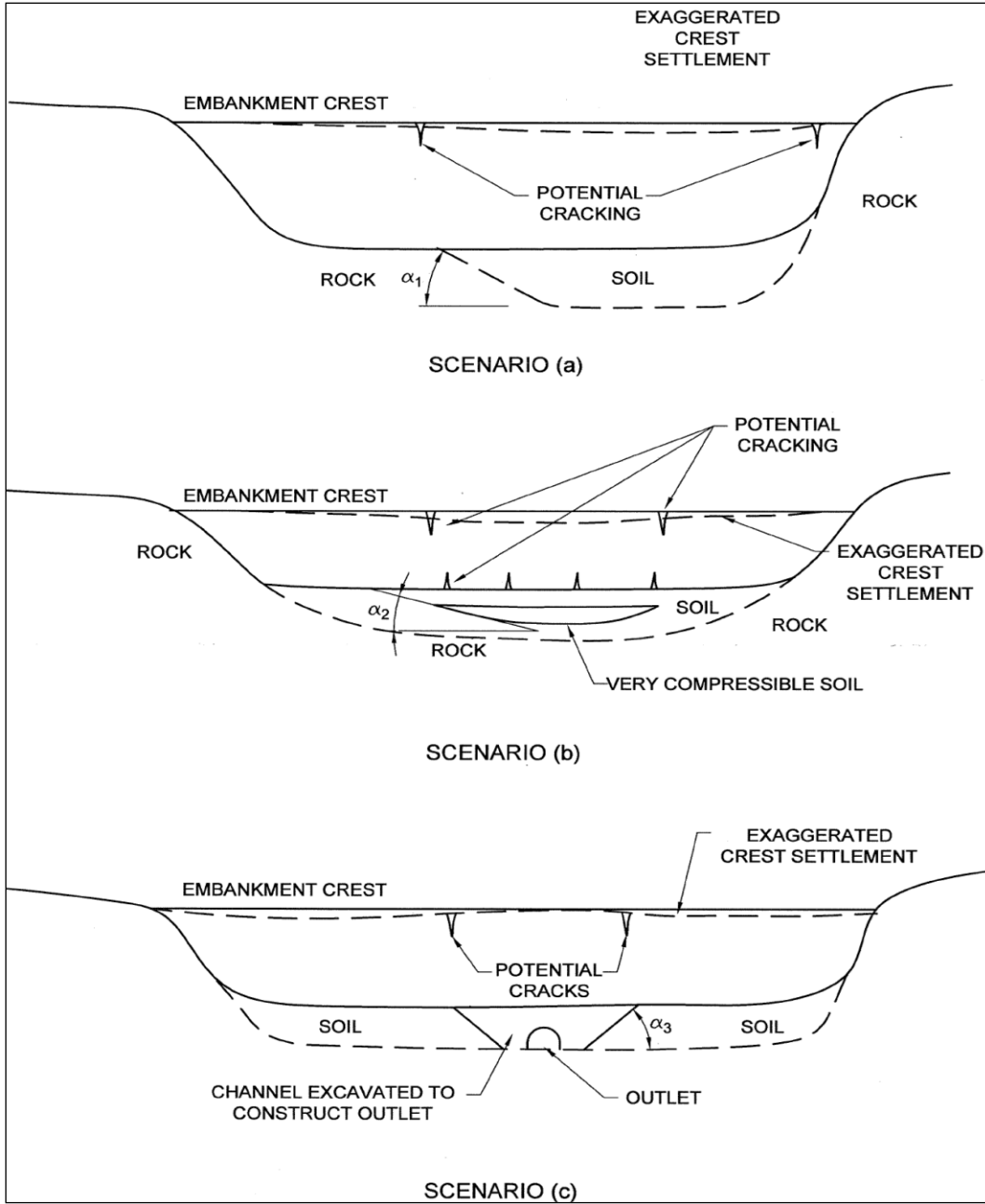

Figure D-6-C-5.—Cracking and hydraulic fracture due to differential settlement in the foundation (Fell et al. 2008).

Appendix D-6-C Concentrated Leak Erosion

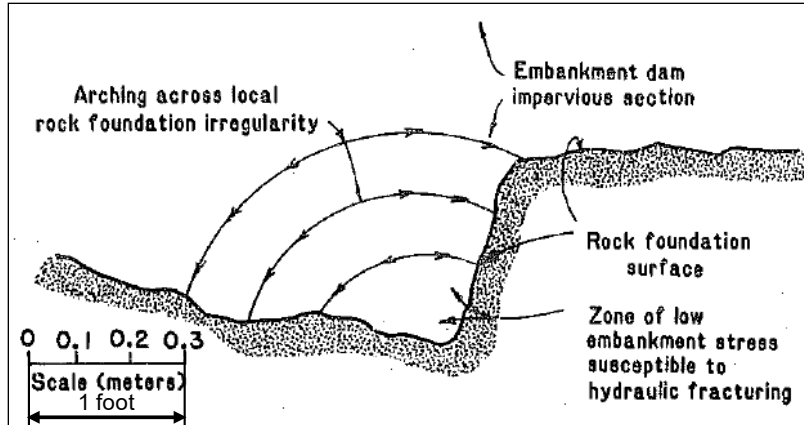

Figure D-6-C-6.—Cracking and hydraulic fracture due to small-scale irregularities in the foundation profile (Sherard 1985b).

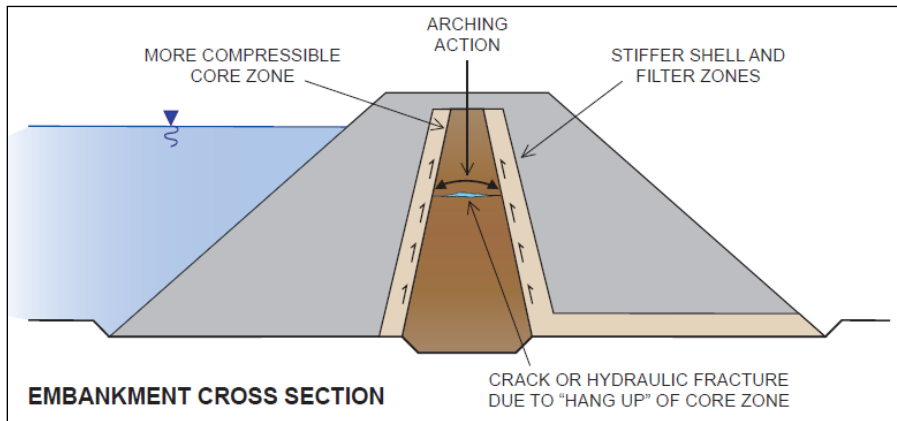

Figure D-6-C-7.—Cracking and hydraulic fracture due to arching of core onto embankment shells (courtesy of Mark Foster).

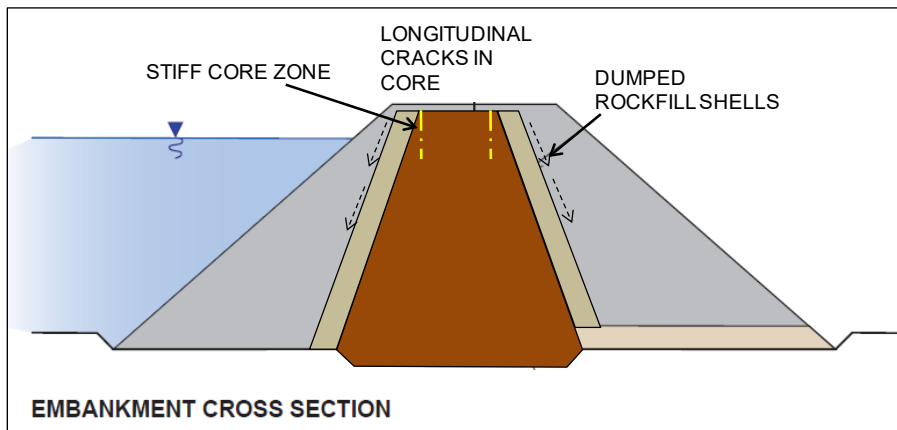

Figure D-6-C-8.—Cracking due to cross-sectional settlement (differential settlement of shell zones) (courtesy of Mark Foster).

Appendix D-6-C Concentrated Leak Erosion

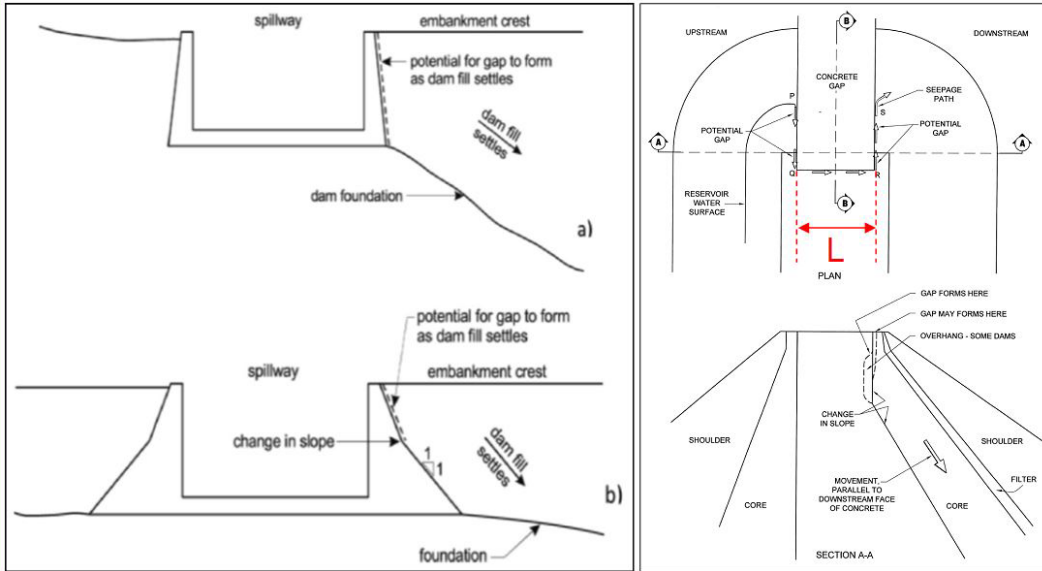

Figure D-6-C-9.—Crack or gap adjacent to spillway or abutment walls and embankment-concrete interfaces (Fell et al. 2008).

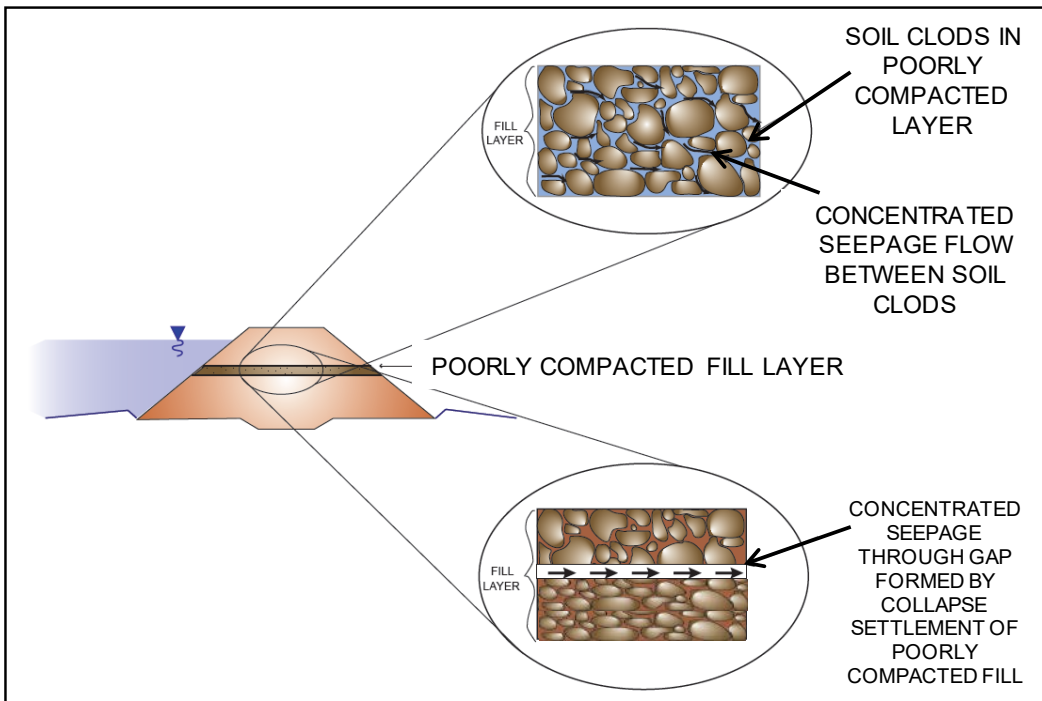

Figure D-6-C-10.—Crack, hydraulic fracture, or openings in poorly compacted and/or segregated layers (courtesy of Mark Foster).

Appendix D-6-C Concentrated Leak Erosion

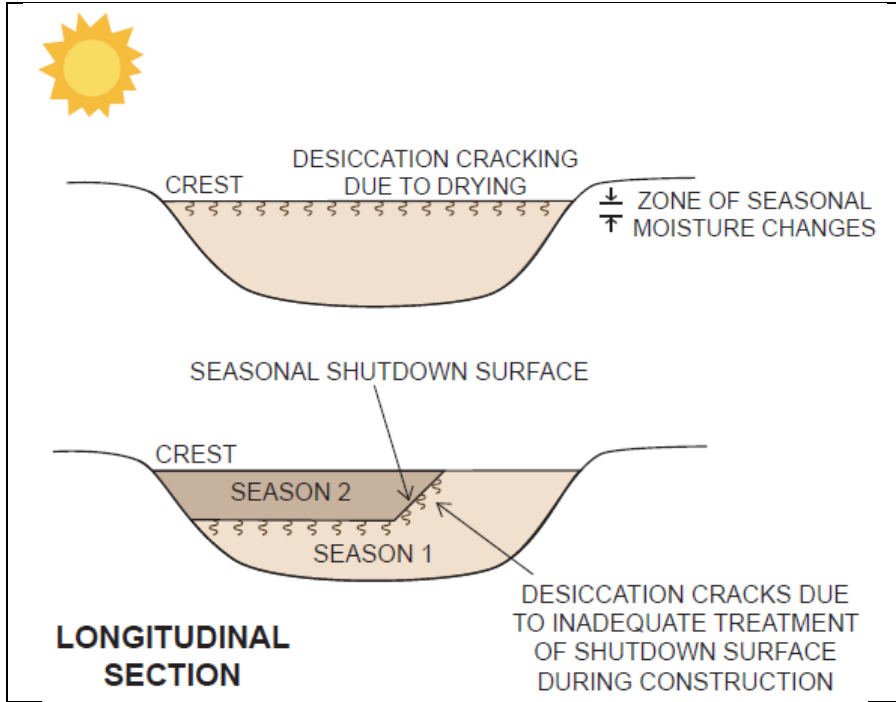

Figure D-6-C-11.—Cracking due to desiccation (courtesy of Mark Foster).

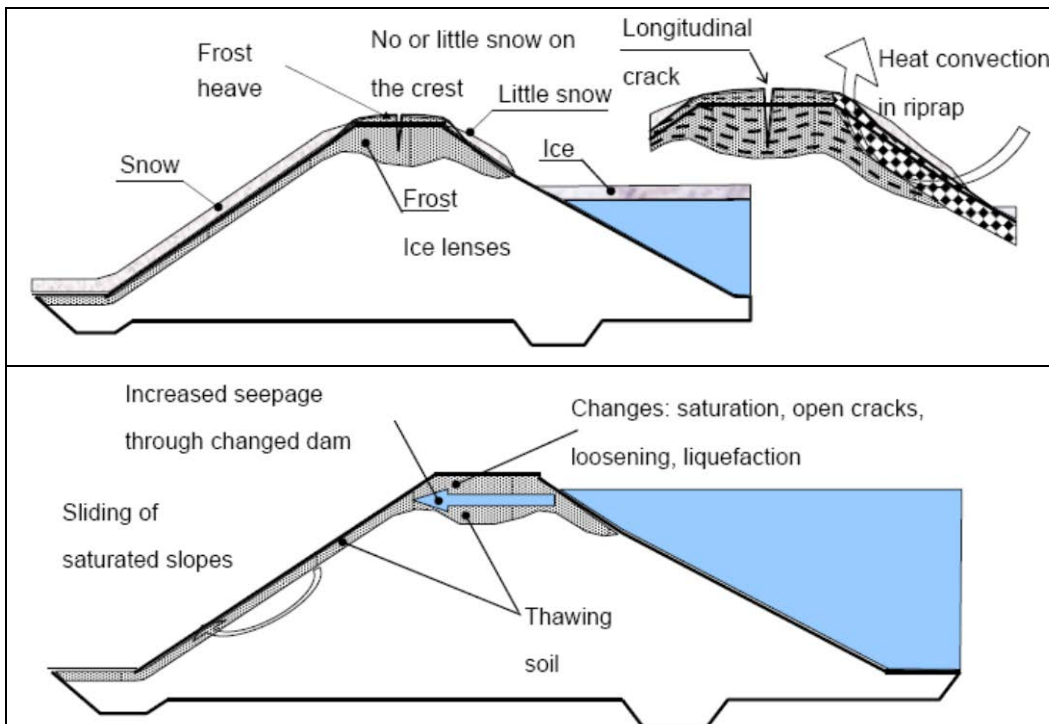

Figure D-6-C-12.—Cracking or high-permeability layers due to freezing (Vuola et al. 2007).

Appendix D-6-C Concentrated Leak Erosion

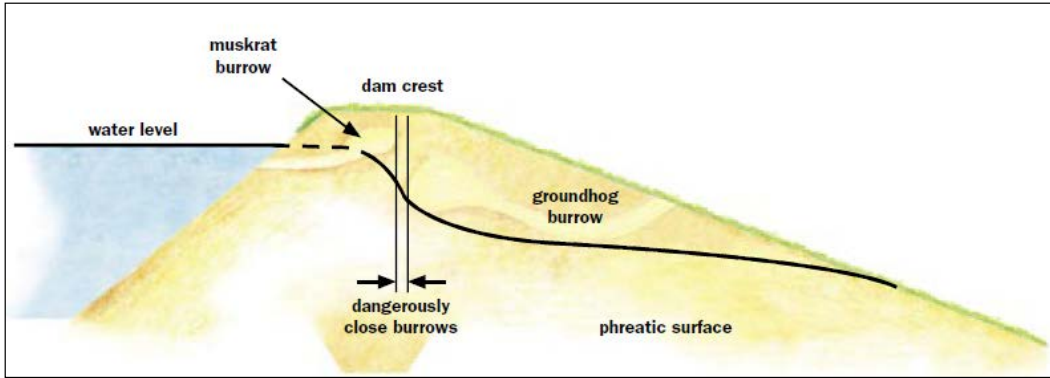

Figure D-6-C-13.—Effects of animal burrows (FEMA 2005).

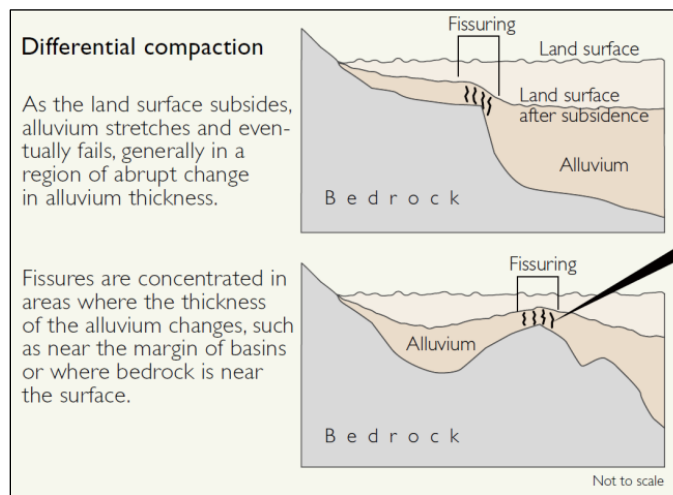

Figure D-6-C-14.—Cracking caused by earth fissures due to subsidence (Galloway et al. 1999).

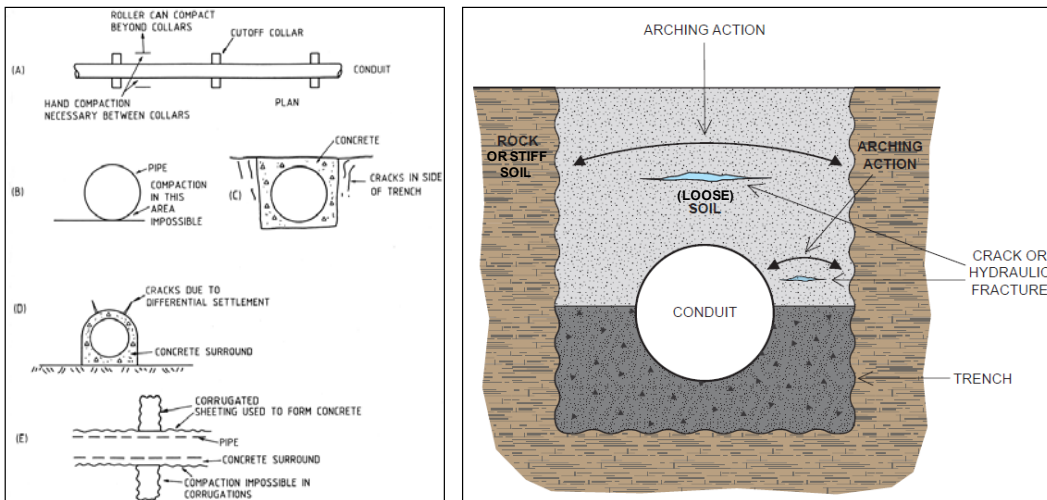

Figure D-6-C-15.—Some causes of piping failures around conduits (Fell et al. 2008).

Appendix D-6-C Concentrated Leak Erosion

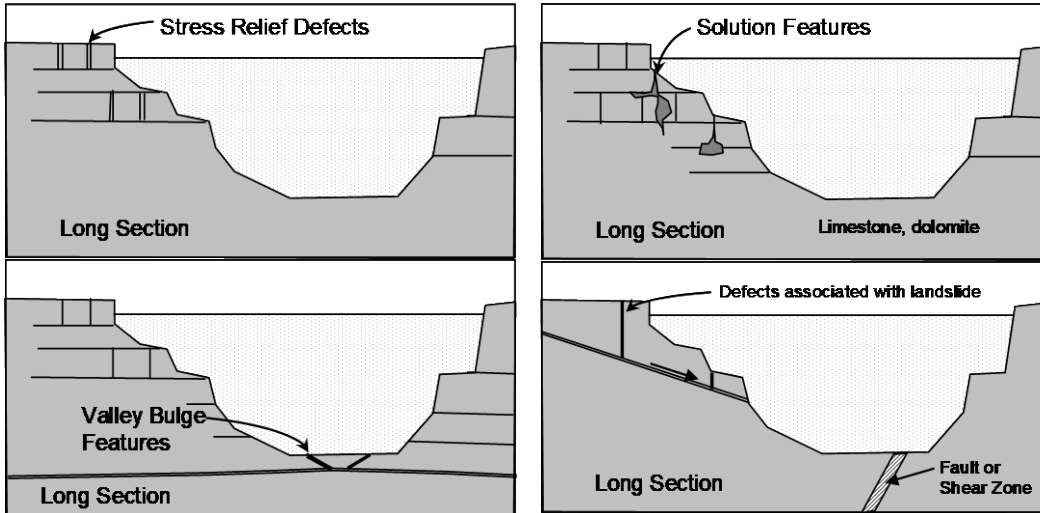

Figure D-6-C-16.—Defects in rock foundations due to geologic processes (Fell et al. 2008).

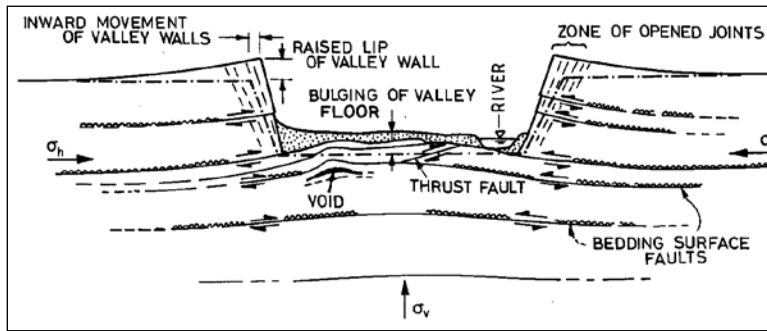

Figure D-6-C-17.—Valley rebound and stress relief effects in valleys in sedimentary and other horizontally bedded rocks (Fell et al. 2008).

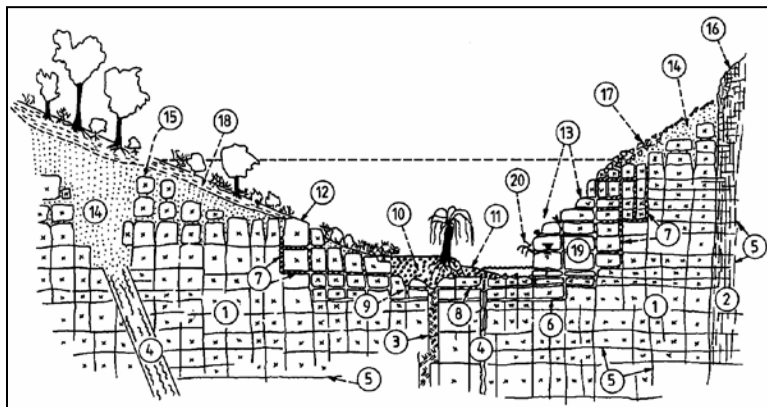

Figure D-6-C-18.—Features in valleys formed in strong jointed rocks (Fell et al. 2008).

Appendix D-6-C Concentrated Leak Erosion

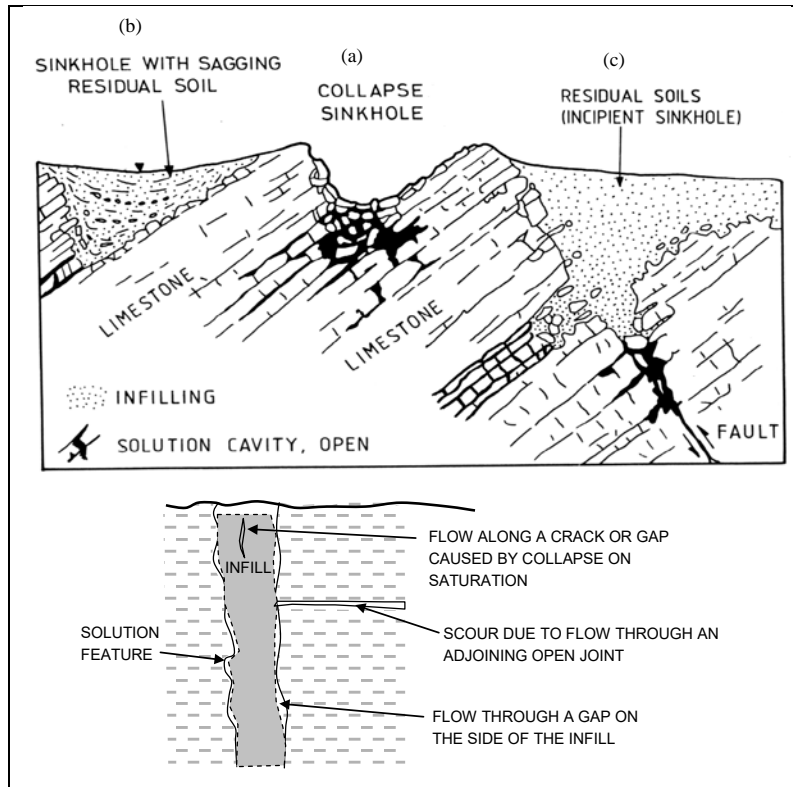

Figure D-6-C-19.—Defects in rock foundations (Fell et al. 2008).

Hydraulic Shear Stress

The hydraulic shear stress in a crack or pipe for the headwater level under consideration is based on the geometry of the embankment core, the assumed pipe or crack dimensions, and the location of the pipe or crack relative to the headwater level so that the flow gradient and velocity can be determined. According to Wan and Fell (2004b), the hydraulic shear stress can be estimated by the following equation:

$$\tau = \rho_w g \left(\frac{\Delta H}{L} \right) \left(\frac{A}{P_w} \right) \quad \text{Equation D-6-C-1}$$

where ρ_w = density of water; g = acceleration due to gravity; ΔH = hydraulic head difference; L = length of pipe or crack over which the hydraulic head difference occurs; A = cross-sectional area of pipe or crack; and P_w = wetted perimeter of pipe or crack. Since the unit weight of water, $\gamma_w = \rho_w g$ and the hydraulic gradient, $i = \Delta H/L$, then the expression can be simplified to the following:

$$\tau = \gamma_w i \left(\frac{A}{P_w} \right) \quad \text{Equation D-6-C-2}$$

Appendix D-6-C Concentrated Leak Erosion

Using this basic equation and the estimated geometry of the pipe or crack, the following approximations can be derived for the hydraulic shear stress.

The assumptions for the estimation of the hydraulic shear stress are:

- Linear head loss from upstream to downstream
- Steady uniform flow along the pipe or crack
- Zero pressure head at the downstream end
- Uniform frictional resistance along the surface of the pipe or crack
- Driving force = frictional resistance

Cylindrical Pipe

For cylindrical pipe, the equation for hydraulic shear stress is the following:

$$\tau = \frac{\rho_w g (H/L) (\pi D^2 / 4)}{\pi D} = \frac{\rho_w g H D}{4L} \quad \text{Equation D-6-C-3}$$

where τ = hydraulic shear stress; ρ_w = density of water; g = acceleration due to gravity; H = hydraulic head at upstream end; L = length of pipe at mid-depth of headwater level under consideration; and D = diameter of pipe. Figure D-6-C-20 provides an example of the geometric inputs to this equation.

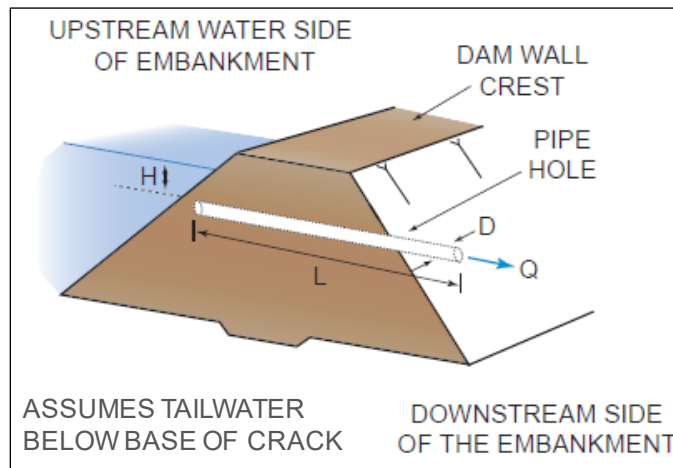

Figure D-6-C-20.—Cylindrical pipe geometry (Fell et al. 2014).

Since $\gamma_w = \rho_w g$ and $i = H/L$, then

$$\tau = \gamma_w i \left(\frac{D}{4} \right) \quad \text{Equation D-6-C-4}$$

Vertical Parallel-Sided Transverse Crack

For vertical parallel-sided transverse crack, the equation for hydraulic shear stress is the following:

$$\tau = \frac{\rho_w g (H/L) (HW)}{2(H+W)} = \frac{\rho_w g H^2 W}{2(H+W)L} \quad \text{Equation D-6-C-5}$$

where τ = hydraulic shear stress; ρ_w = density of water; g = acceleration due to gravity; H = hydraulic head at upstream end; L = length of crack at mid-depth of headwater level under consideration; and W = width of crack. Figure D-6-C-21 provides an example of the geometric inputs to this equation.

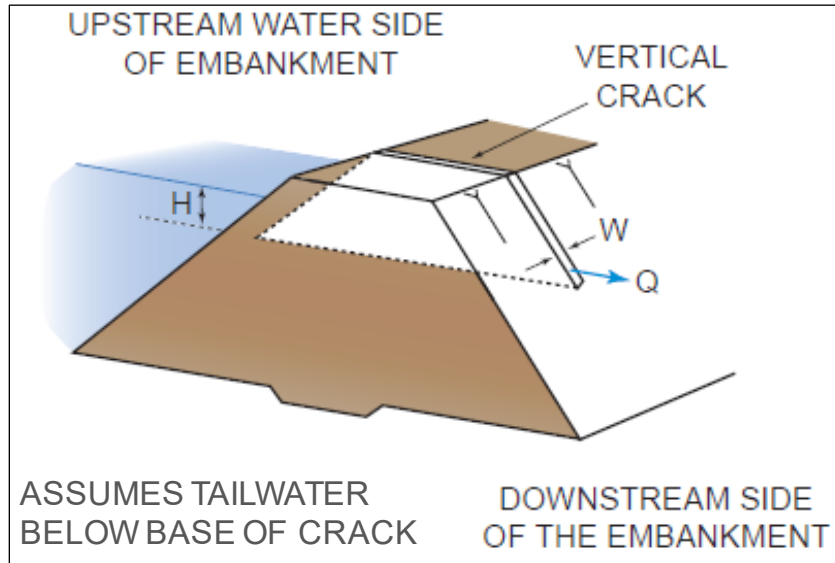

Figure D-6-C-21.—Vertical parallel-sided transverse crack geometry (Fell et al. 2014).

Since $H + W \approx H$ (because $H \gg W$), $\gamma_w = \rho_w g$ and $i = H/L$, then the equation can be simplified to the following:

$$\tau \approx \gamma_w i \left(\frac{W}{2} \right) \quad \text{Equation D-6-C-6}$$

Vertical Uniformly Tapered Transverse Crack

For vertical uniformly tapered transverse crack, the equation for hydraulic shear stress is the following:

$$\tau = \frac{\rho_w g (H/L) (HW_H/2)}{2(H^2 + W_H^2/4)^{0.5} + W_H} \quad \text{Equation D-6-C-7}$$

Where:

- τ = Hydraulic shear stress
- ρ_w = Density of water
- G = Acceleration due to gravity
- H = Hydraulic head at upstream end
- L = Length of crack at mid-depth of headwater level under consideration
- W_H = Width of crack at H

Figure D-6-C-22 provides an example of the geometric inputs to this equation.

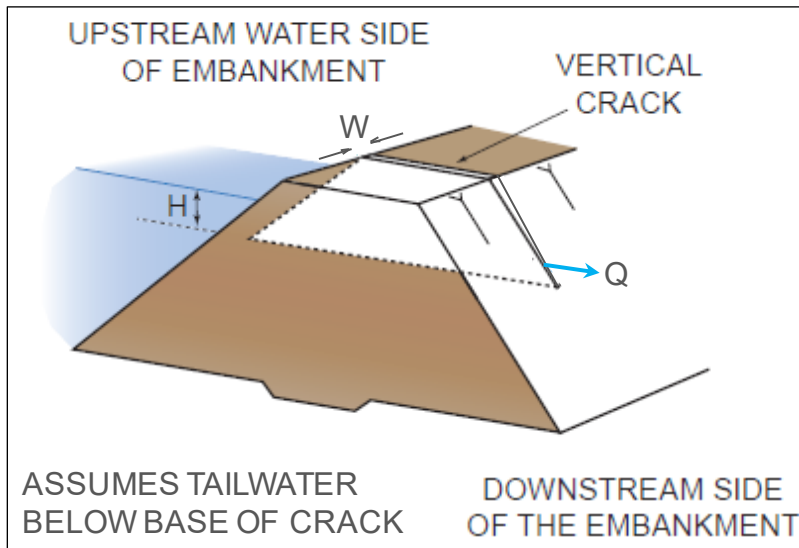

Figure D-6-C-22.—Uniformly tapered transverse crack geometry (adapted from Fell et al. 2014)

Since $2(H^2 + W_H^2/4)^{0.5} + W_H \approx 2H$ (because $H \gg W_H$), $\gamma_w = \rho_w g$ and $i = H/L$, then the equation can be simplified to the following:

$$\tau \approx \gamma_w i \left(\frac{W_H}{4} \right) \quad \text{Equation D-6-C-8}$$

Critical Crack Width

The above approximate relationships can also be used in a reverse manner to estimate the critical continuous pipe diameter or crack width for initiation, which the team can then use as a more likely or less likely factor in assessing the likelihood of a flaw and initiation of concentrated leak erosion:

$$D_c = \frac{4\tau_c}{i\gamma_w} \text{ for cylindrical pipe}$$

$$W_c = \frac{2\tau_c}{i\gamma_w} \text{ for vertical parallel-sided transverse crack}$$

$$W_c = \left(\frac{4\tau_c}{i\gamma_w}\right) \left(\frac{D}{H}\right) \text{ for vertical uniformly tapered transverse crack}$$

Initiation

The critical shear stress (τ_c) can be compared to the estimated hydraulic shear stress for the headwater level under consideration (τ) to help assess the likelihood of initiation of concentrated leak erosion. The factor of safety can be estimated as:

$$FS = \frac{\tau_c}{\tau}$$

Equation D-6-C-9

Sensitivity or uncertainty analysis is recommended. In addition to a best estimate, a range of values should be considered from a reasonable low estimate to a reasonable high estimate. Probability distributions can also be assigned for the crack geometry and critical shear stress to be used in a Monte Carlo simulation to assess the probability of a factor of safety against initiation of concentrated leak erosion less than one.

Exceeding the limit-state condition simply provides an indication of the likelihood for concentrated leak erosion to initiate and progress. Analytical results should be used to help inform judgment and develop a list of more likely and less likely factors during an elicitation to develop actual probabilities with due consideration for uncertainty.

An example of portrayal of analytical results with sensitivity analysis is shown on figure D-6-B-23. In this example, a best estimate for critical shear stress was estimated by a risk team during an elicitation, along with reasonable low and reasonable high estimates. The hydraulic shear stress was then estimated for a range of pipe diameters and headwater levels. Based upon the estimated pipe diameter or range of pipe diameters for the flaw, this figure can be used to help develop a list or more likely and less likely factors for initiation of concentrated leak erosion as a function of headwater level.

Appendix D-6-C Concentrated Leak Erosion

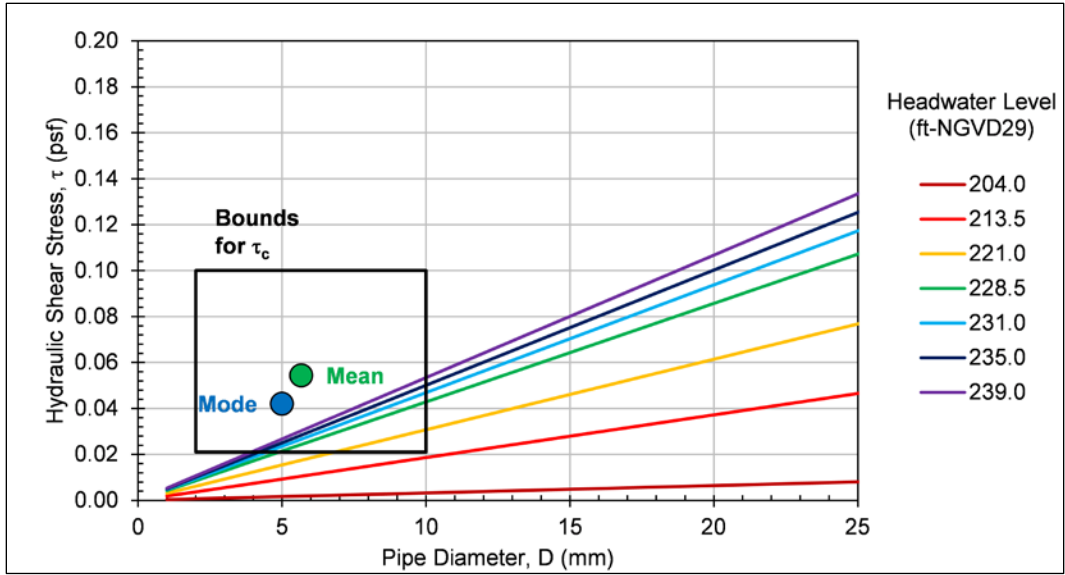

Figure D-6-C-23.—Sample portrayal of analytical results for initiation of concentrated leak erosion.

APPENDIX D-6-D

Soil Contact Erosion

Geometric Condition (Screening-Level Assessment)

Fine soil layers that do not satisfy geometric criteria for filtration are not susceptible to soil contact erosion. Assessing the susceptibility to soil contact erosion for any risk assessment starts with a review of the particle-size distribution (i.e., geometric condition). Several researchers have proposed expressions for the geometric and hydraulic conditions, which are summarized in this appendix. Those geometric condition are very similar to the NE condition ($D_{15}/d_{85} < 9$) of Foster and Fell (1999, 2001). Modern filter design criteria can be used as an initial screening and must be used for the design of a new filter. For assessment of existing dams and levees, the Foster and Fell criteria (1999, 2001) can be used to assess filters (coarse layers) that do not satisfy modern filter design criteria (i.e., NE condition).

Experimental results of soil contact erosion for non-plastic soils for the geometric and hydraulic conditions for the detachment and transport of particles resulted in the domains shown in table D-6-D-1. For the “geometric domain” where D_{15}/d_{85} is less than the thresholds in the third column, initiation of soil contact erosion is very unlikely to occur because there is geometrical filtration regardless of the hydraulic loading.

Table D-6-D-1.—Domain of Geometric and Hydraulic Influence for Non-Plastic Soils (Bonelli 2013)

	Grading ratio D_{15}/d_{85} →				
Brauns (1985) soil with $n=0.4$	Geometrical condition	7.5	Geometrical and Hydraulic condition	25	Hydraulic condition
Wörman (1992) soil with $D_{15}=0.88D_H$				14.6	
Den Adel (1994) soil with $d_{85}=d_{50}/0.9$		8.1		11.7	

Hydraulic Condition

The critical gradient in the coarse layer can vary significantly depending on its permeability. However, the “critical” Darcy velocity for initiation of soil contact erosion does not significantly depend on its permeability and is only related to the fine soil’s resistance to erosion. Therefore, the Darcy velocity is often a good indicator of the hydraulic loading and compared to the critical velocity for initiation of soil contact erosion. The critical velocity can be compared to the estimated Darcy velocity for the headwater level under consideration to help assess the likelihood of initiation and progression of soil contact erosion.

Appendix D-6-D Soil Contact Erosion

The hydraulic condition for soil contact erosion depends of the configuration of the fine and coarse layers. The influence of the coarse layer on the initiation of soil contact erosion can be neglected if D_{15}/d_{85} is greater than the values listed in the fifth column of table D-6-D-1 for the “hydraulic condition” domain. For those situations, the hydraulic loading condition controls, and there is no filtration effect. In the “geometrical and hydraulic condition” domain, the critical velocity is also a function of the coarse soil grading, and the hydraulic loading to initiate soil contact erosion is higher than the “hydraulic condition” domain.

Brauns (1985) proposed an expression for critical velocity which provides a good approximation for sand below gravel:

$$\begin{aligned}
 U_{crit} \text{ (m/s)} &= 0.65n_F \sqrt{\left(\frac{\rho_s - \rho_w}{\rho_w}\right) g d_{50}} \\
 &= 0.65n_F \sqrt{(G_s - 1) g d_{50}}
 \end{aligned}
 \tag{Equation D-6-D-1}$$

where n_F = porosity of the coarse soil (gravel); ρ_s = density of the base soil (sand) particles (kg/m^3); ρ_w = density of water ($1,000 \text{ kg/m}^3$); G_s = specific gravity of the sand particles; g = acceleration of gravity (9.81 m/s^2); and d_{50} = mean grain size of the base soil (sand).

Guidoux et al. (2010) measured critical velocities and critical hydraulic gradients for various base soils and recommended using the effective grain diameter (d_H) of Koženy (1953) instead of d_{50} for a more representative particle-size description for the base soil to predict the critical velocity:

$$d_H = \left(\sum_{j=1}^m \frac{F_j}{d_j} \right)^{-1}
 \tag{Equation D-6-D-2}$$

where d_j (mm) = particle-size of the fraction j of the base soil gradation curve; and F_j (-) = mass fraction of the fraction j . For a well-graded soil, $d_H \approx d_{50}$. Their expression for critical velocity can be used for sands, silts, or sand/clay mixtures below gravel:

$$\begin{aligned}
 U_{crit} \text{ (m/s)} &= 0.65n_F \sqrt{\left(\frac{\rho_s - \rho_w}{\rho_w}\right) g d_H \left(1 + \frac{\beta}{d_H^2}\right)} \\
 &= 0.65n_F \sqrt{(G_s - 1) g d_F \left(1 + \frac{\beta}{d_H^2}\right)}
 \end{aligned}
 \tag{Equation D-6-D-3}$$

Appendix D-6-D Soil Contact Erosion

where n_F = porosity of the coarse soil (gravel); ρ_s = density of the base soil particles (kg/m^3); ρ_w = density of water ($1,000 \text{ kg/m}^3$); g = acceleration of gravity (9.81 m/s^2); G_s = specific gravity of the sand particles; d_H = effective grain diameter of the base soil; and β = empirical coefficient. Several parameters influence the coefficient β , which was estimated by Guidoux et al. (2010) by fitting the above equation to the experimental data and assuming it did not vary among the tested soils. The best fit obtained for β was $5.3\text{E-}09 \text{ m}^2$.

The relationships for critical velocity for both methods are shown on figure D-6-D-1. Both methods give the same results for sand below gravel. Since the D_{50} of sand can be readily assessed from the gradation curves, the Brauns (1985) method is the simplest to use and provides a good approximation for sand below gravel. For other “base” soils, the Guidoux et al. (2010) method must be used.

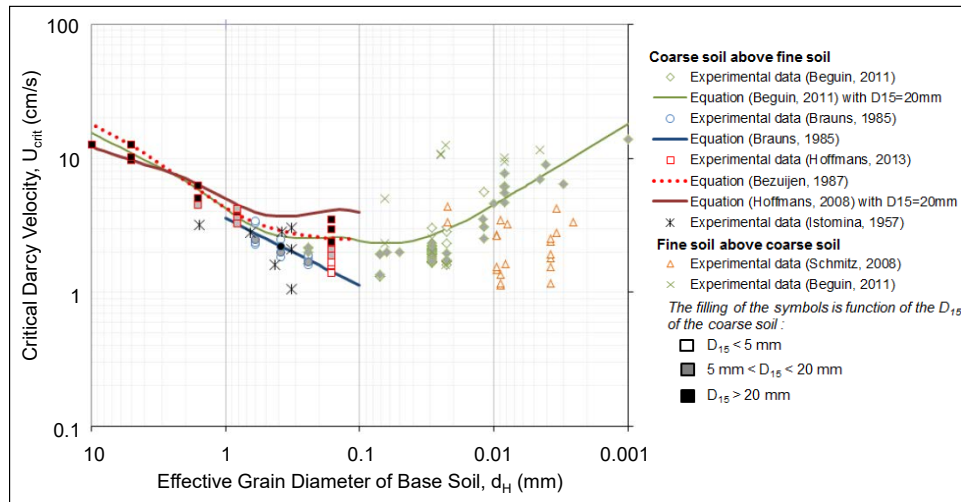

Figure D-6-D-1.—Critical velocity for initiation and progression of soil contact erosion (ICOLD 2015).

Schmitz (2007) conducted testing for erosion of silt layers above coarse layers. In contrast to the configuration of fine soil below coarse soil, he noticed an influence of the confining stress on the critical velocity. For higher vertical stresses on the sample, he measured higher critical velocities. Generally, the critical velocities measured were of the same order of magnitude as the reverse configuration, between 1 and 10 cm/s but lower than the critical velocities proposed by Guidoux et al. (2010).

Initiation

The critical velocity can be compared to the estimated Darcy velocity for the headwater level under consideration to help assess the likelihood of initiation and progression of soil contact erosion. The factor of safety can be estimated as:

$$FS = \frac{U_{crit}}{k_h i} \quad \text{Equation D-6-D-4}$$

Where:

- k_h = Hydraulic conductivity (horizontal) of the coarse layer
- i = Aepage gradient for the reservoir level under consideration

Note: This is Darcy velocity and does not need adjustment for porosity.

Sensitivity or uncertainty analysis is recommended. In addition to a best estimate, a range of values should be considered from a reasonable low estimate to a reasonable high estimate. Probability distributions can also be assigned for the mean grain size of the base soil (sand), effective grain diameter (d_H) of the base soil, and hydraulic conductivity (horizontal) of gravel to be used in a Monte Carlo simulation to assess the probability of a factor of safety against initiation of soil contact erosion less than one.

Exceeding the limit-state condition simply provides an indication of the likelihood for soil contact erosion to initiate and progress. Analytical results should be used to help to help inform judgment and develop a list of more likely and less likely factors during an elicitation to develop actual probabilities with due consideration for uncertainty.

An example of portrayal of analytical results with sensitivity analysis is shown on figure D-6-D-2. In this example, a range of hydraulic conductivity and effective grain diameter of the base soil were estimated by a risk team during an elicitation. Based on the estimated Darcy velocities, this figure can be used to help develop a list or more likely and less likely factors for initiation of and progression of soil contact erosion as a function of reservoir level.

Appendix D-6-D Soil Contact Erosion

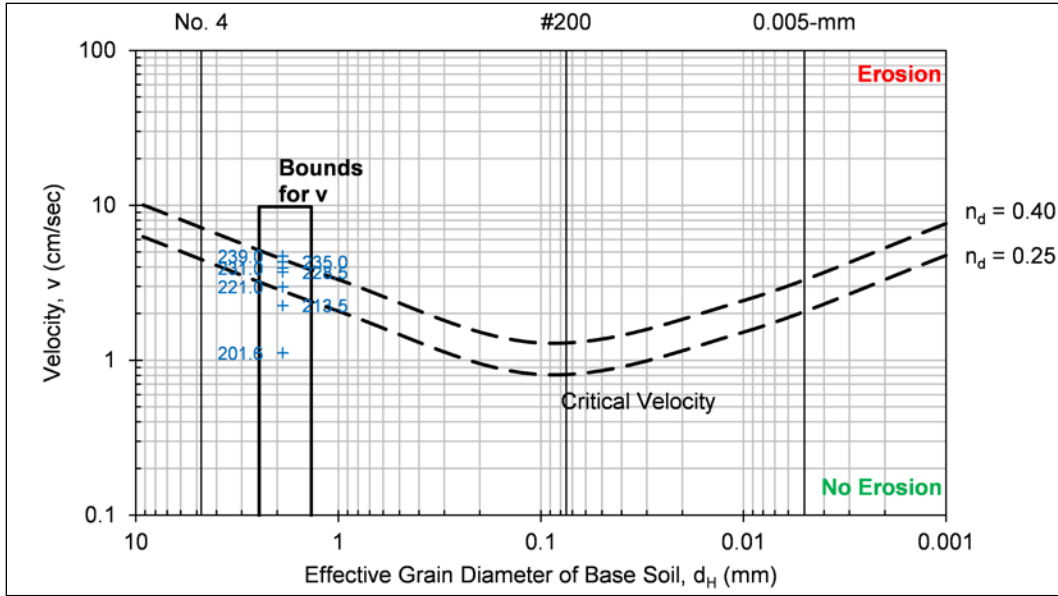

Figure D-6-D-2.—Example portrayal of analytical results for initiation of soil contact erosion.

APPENDIX D-6-E

Critical Gradients for Evaluation of Backward Erosion
Piping

Terzaghi et al. (1996) showed that backward erosion piping (BEP) will initiate when a “heave” or zero effective stress condition occurs in sands subject to upward through-seepage. The basis for design guidance is to prevent the uplift or blowout condition, and thus initiation and progression of backward erosion piping. Based on experience with Mississippi River flooding, USACE developed an analytical procedure for assessing levee underseepage and vertical exit gradients commonly known as “blanket theory” for seven scenarios (with and without confining layers) which are described in Engineering Manual 1110-2-1913 (USACE 2000). Flow nets and two-dimensional finite element modeling (e.g. SEEP/W) are two commonly used techniques to estimate gradients.

To sustain piping, the seepage flow must be maintained at or above the critical gradient, and a mechanical condition is necessary to sustain a continuous roof for the developing pipe either by the embankment or a confining layer. Test results from studies by Weijers and Sellmeijer (1993), Schmertmann (2000), Sellmeijer et al. (2011) have shown that backward erosion can progress at global gradients of 40 to 60 percent of the critical gradients to cause backward erosion to initiate, especially for fairly uniform, fine to medium sands where critical global gradients can be as low as 0.02.

To help assess the likelihood of the hydraulic condition for progression of backward erosion piping, the global or horizontal gradient in the foundation can be compared to the critical gradient for progression of a pipe. Methods to evaluate the critical gradient for progression of a pipe include line-of-creep methods (Bligh 1910 and Lane 1935), Sellmeijer’s piping rule (1993, 2011), and Schmertmann’s methodology (2000). ***Multiple methods are suggested to help inform judgment. The correct application of these methods requires an understanding of the context from which each method was developed.*** Robbins and van Beek (2015) provide a more detailed review of the background, advantages, and disadvantages of each method and the various laboratory test conditions (e.g., density, exit configuration, soil characteristics, and scale effects) that significantly impact the findings. For example, the Sellmeijer and Schmertmann “average gradient” methods can only be used for situations that have a purely two-dimensional seepage regime (i.e., only applicable to situations that have uniform boundary conditions parallel to the embankment centerline such as an exposed ditch or no confining layer). Some methods may not apply to the materials under consideration. For example, Sellmeijer’s piping rule is only applicable within the range of soils tested. ***For soils beyond the suggested ranges and differing exit configurations, the methods are not necessarily applicable, and the actual critical gradients may be quite different than what is estimated.***

All other parameters remaining the same, the likelihood of BEP is:

- Decreased by increasing particle size
- Decreased by increased coefficient of uniformity
- Decreased by increasing relative density

Appendix D-6-E Critical Gradients for Evaluation of Backward Erosion Piping

- Decreased by decreasing permeability
- Increased by the thickness of the piping layer
- Increased by presence of an underlying layer of higher permeability
- Increased by increased horizontal to vertical permeability ratio
- Slightly decreased by angularity of the particles
- Not changed by confining stress
- Increased for turbulent flow (Annandale 2007)

Terzaghi et al. (1996) indicate that the mechanics of piping “defy theoretical approach,” and the “results of theoretical investigations into the mechanical effects of the flow of seepage serve merely as a guide for judgment.” The analytical methods described in this appendix merely provide a starting point to help develop a list of more likely and less likely factors during an elicitation of probability estimates.

Critical Gradient for Initiation of a Pipe

BEP will initiate when a “heave” or zero effective stress condition occurs in soils subject to upward through-seepage. The heave equation or critical exit gradient from Terzaghi (1943) is given by:

$$i_{cr} = \frac{\gamma_b}{\gamma_w} \quad \text{Equation D-6-E-1}$$

where γ_b = buoyant unit weight of the soil; and γ_w = unit weight of water.

Several researchers have evaluated seepage exiting sloping surfaces, where lower exit gradients are required for initiation of erosion. For example, van Rhee and Bezuijen (1992) and Kovács (1981) proposed theoretical approaches, whereas the empirical model of Keizer et al. (2016) considers actual trends observed during laboratory testing to develop a prediction of critical gradients based on exit face inclination. Each of these approaches reduces to the “classical” Terzaghi heave equation for vertical upward seepage with horizontal exit faces.

An example of portrayal of analytical results is shown on figure D-6-E-1. In this example, the critical gradient for vertical (upward) seepage at the downstream toe was estimated. Based on the estimated vertical (upward) exit gradients from a seepage analysis, this figure can be used to help develop a list of more likely and less likely factors for initiation of BEP as a function of headwater level.

A Taylor series method of reliability analysis can be performed for selected random variables such as foundation layer thickness, permeability, unit weight, anisotropy, etc. The Taylor series provides probabilities of a factor of safety against heave of less than one for the reservoir level under consideration

Appendix D-6-E Critical Gradients for Evaluation of Backward Erosion Piping

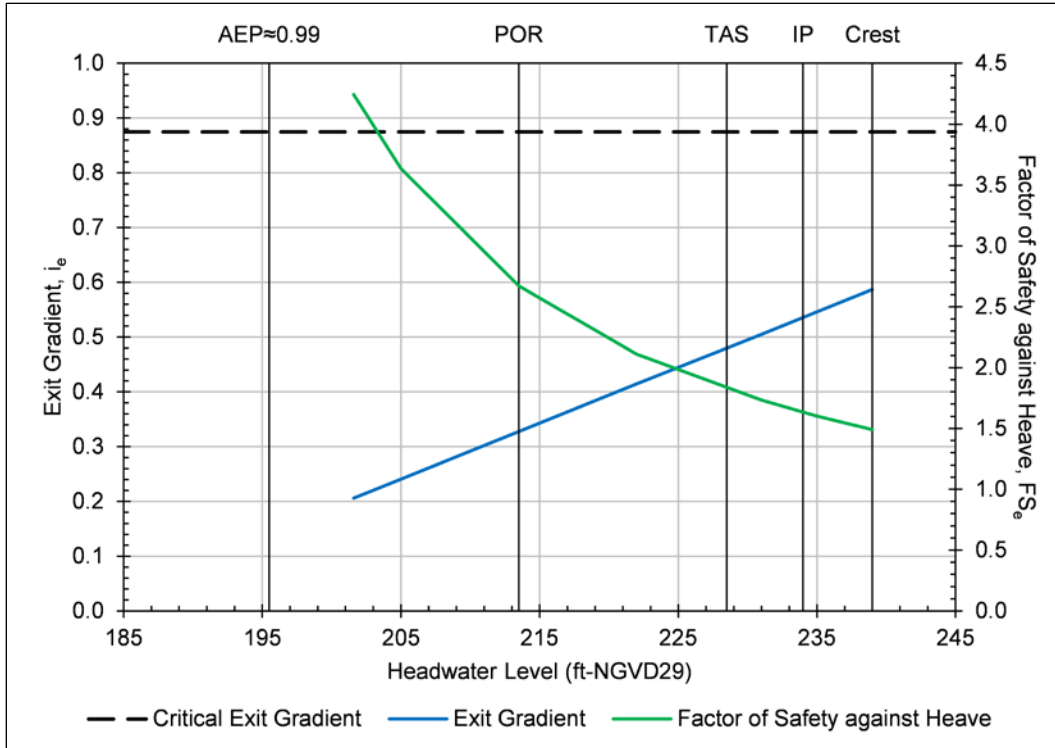

Figure D-6-E-1.—Sample portrayal of analytical results for initiation of BEP Taylor series method of reliability analysis.

(i.e., probabilistic seepage analysis). For levees, USACE has performed such analyses in conjunction with blanket theory calculations since the 1990s.

Exceeding the limit-state condition simply provides an indication of the likelihood for backward erosion to initiate. Analytical results should be used to help inform judgment and develop a list of more likely and less likely factors during an elicitation to develop actual probabilities with due consideration for uncertainty.

The methodology is described in USACE (2014). Estimates of the mean and standard deviations are required, and can be developed through an elicitation and application of the six-sigma rule, where the standard deviation is estimated:

$$\sigma = \frac{HCV - LCV}{6} \qquad \text{Equation D-6-E-2}$$

Where:

- HCV = Highest conceivable value
- LCV = Lowest conceivable value

Appendix D-6-E Critical Gradients for Evaluation of Backward Erosion Piping

For the mean plus or minus three standard deviations, 99.73 percent of the area under the normal distribution is included. Therefore, essentially all of the values represented by the normal distribution curve are included.

An example of portrayal of Taylor series results for a given reservoir level is shown on figure D-6-E-2. In this example, four random variables were considered: horizontal permeability of upper layer (Kha), horizontal permeability of lower layer (Khb), thickness of upper layer (Ta), thickness of lower layer (Tb), and P_1 = probability of a factor of safety against heave less than one. For a given reservoir level, nine separate seepage analyses were performed for the combination of random variables shown to obtain an estimate of the exit gradient at the downstream toe of the embankment dam. The process was then repeated for the other reservoir levels.

Parameter	Random Variables			
	Kha (fpd)	Khb (fpd)	Ta (ft)	Tb (ft)
Mean, μ	40	500	10	80
Lowest conceivable value, LCV	15	300	10	40
Highest conceivable value, HCV	60	750	10	160
Standard deviation, $\sigma = (HCV-LCV)/6$	7.5	75	0	20

Critical gradient for particle detachment, i_{cr} <u>0.875</u>							
Run Case	Random Variables				i_e	FS_e	Var(FS_e)
	Kha (fpd)	Khb (fpd)	Ta (feet)	Tb (feet)			
1	40	500	10	80	0.705	1.242	0.019
2	32.5	500	10	80	0.793	1.103	
3	47.5	500	10	80	0.635	1.378	
4	40	425	10	80	0.625	1.399	0.018
5	40	575	10	80	0.775	1.129	
6	40	500	10	80	0.705	1.242	0.000
7	40	500	10	80	0.705	1.242	
8	40	500	10	60	0.601	1.455	0.028
9	40	500	10	100	0.781	1.121	
$\sigma_{FS} = [\sum Var(FS)]^{0.5}$		0.255		$\beta = \ln[E(FS)/(1+V_{FS}^2)^{0.5}]/[\ln(1+V_{FS}^2)]^{0.5}$		0.96	
$V_{FS} = \sigma_{FS} / E(FS)$		0.205		$P_1 = P(FS < 1) = \Phi(-\beta)$		1.68E-01	

Figure D-6-E-2.—Sample Taylor series results for probabilities of a factor of safety against heave less than one.

Critical Gradient for Progression of a Pipe

Bligh (1910) and Lane” (1935)

Line-of-creep methods such as Bligh (1910) and Lane (1935) are still in use by some practitioners. They can be used for screening-level assessment of the critical gradient for progression of a pipe. Both empirical methods involve estimating the seepage path length beneath concrete structures (weirs) including cutoff walls. For application to embankment dams and levees, the seepage path length would be beneath the roof-forming material including upstream and downstream blankets or berms, cutoff walls, cutoff or inspection trenches, etc. The creep ratio is calculated as the total seepage path length divided by the hydraulic head difference. For Lane’s method, the horizontal seepage path lengths are weighted 3 times less than the vertical seepage path lengths. Hence, it is often referred to as a “weighted creep” method.

$$C = \frac{L_1+W+L_2+2D}{h} \text{ for Bligh} \quad \text{Equation D-6-E-3}$$

$$C_w = \frac{(L_1+W+L_2)/3+2D}{h} \text{ for Lane} \quad \text{Equation D-6-E-4}$$

Where:

L_1 = Length of upstream blanket or berm; W = width of base of embankment

L_2 = Length of downstream blanket or berm; and d = depth of vertical structure (e.g., cutoff or weir).

To assess the likelihood of progression of backward erosion piping, the creep ratio for the reservoir level under consideration is compared to the minimum (or safe) creep ratio for the piping material in table D-6-E-1. Progression of backward erosion would be expected if the creep ratio is less than the minimum creep ratio.

The creep ratio is the reciprocal of the average gradient in the foundation for the reservoir level under consideration (i_{avf}), and the minimum creep ratio is the reciprocal of the critical gradient for progression of a pipe ($i_{adv} = 1/C$ or $i_{adv} = 1/C_w$).

Appendix D-6-E Critical Gradients for Evaluation of Backward Erosion Piping

Table D-6-E-1.—Minimum Creep Ratios

Piping Material	Bligh (1910)	Lane (1935)
Very fine sand or silt	18	8.5
Fine sand	15	7.0
Medium sand	#N/A	6.0
Coarse sand	12	5.0
Fine gravel	#N/A	4.0
Medium gravel	#N/A	3.5
Gravel and sand	9	#N/A
Coarse gravel, including cobbles	#N/A	3.0

Sellmeijer et al. (2011)

Sellmeijer et al. at Delft University of Technology (TU Delft) in the Netherlands developed a mathematical model for piping based on laboratory flume tests by Sellmeijer (1988), Sellmeijer and Koenders (1991), and Koenders and Sellmeijer (1992). The tests were performed mostly on fine to medium, uniform sands uniform ($1.58 \leq c_u \leq 3.53$) with some medium to coarse sands. Sellmeijer et al. (2011) extended and updated the piping model based on the results of several small-scale, seven medium-scale, and four large-scale field (IJKdijk) tests. The critical gradient for progression of a pipe is estimated as:

$$i_{adv} = F_R F_S F_G \quad \text{Equation D-6-E-5}$$

Where:

F_R = Resistance factor (strength of the layer subject to backward erosion);

F_S = Scale factor (relating pore size and seepage size); and F_G = geometrical shape factor.

The methodology applies to 2D seepage with plane or ditch exits parallel to the embankment for fine to medium sands within the limits of the test parameters shown in table D-6-E-2. Van Beek et al. (2015) found that 3D configurations with flow towards a single point (e.g., hole in a confining layer) resulted in significantly smaller critical gradients than predicted by the model. In both small and medium-scale experiments, the model overestimated the critical gradient by a factor of approximately 2.

Appendix D-6-E Critical Gradients for Evaluation of Backward Erosion Piping

Table D-6-E-2.—Parameter Limits During Piping Model Testing (Sellmeijer et al. 2011)

Parameter	Minimum	Maximum	Mean
Relative Density, RD (percent)	34	100	72.5
Coefficient of Uniformity, U	1.3	2.6	1.81
Roundness, KAS (percent)	35	70	49.8
Particle Size, d_{70} (mm)	0.150	0.430	0.208

Resistance Factor

The resistance factor (F_R) is calculated as:

$$F_R = \eta(G_s - 1) \tan(\theta) \left(\frac{RD}{72.5}\right)^{0.35} \left(\frac{U}{1.81}\right)^{0.13} \left(\frac{KAS}{49.8}\right)^{-0.02} \quad \text{Equation D-6-E-6}$$

Where:

KAS = Roundness of the particles, which can be visually obtained using figure D-6-E-3

RD = Relative density (percent)

U = Coefficient of uniformity

G_s = Specific gravity of soil particles

θ = Bedding angle (deg)

η = White's (1940) constant

The bedding angle and White's constant are held constant in Dutch practice with values of 37 degrees and 0.25, respectively.

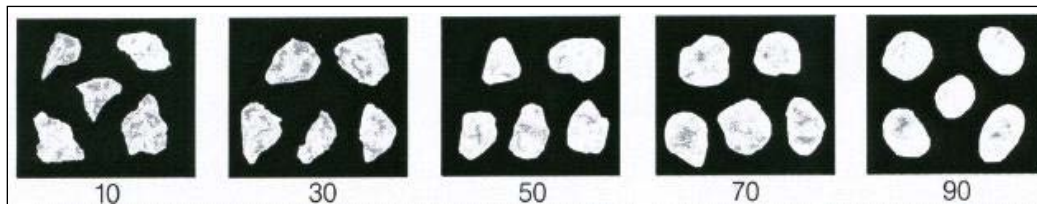

Figure D-6-E-3.—KAS Indication of Angularity (van Beek et al. 2010)

Appendix D-6-E Critical Gradients for Evaluation of Backward Erosion Piping

Van Beek et al. (2010) indicate that KAS and U appear to be of less importance than the other sand characteristics and have a weak influence on the critical gradient. Therefore, the U and KAS terms in the equation for F_R are sometimes ignored.

Scale Factor

The scale factor (F_s) is calculated as:

$$F_s = \frac{d_{70}}{(\kappa L)^{1/3}} \left(\frac{0.000208}{d_{70}} \right)^{0.6} \quad \text{Equation D-6-E-7}$$

Where:

- d_{70} = Particle size (m) for which 70 percent is finer (by weight)
- L = Seepage path length (m) through the piping layer (measured horizontally)
- κ = Intrinsic permeability (m^2) of the piping layer which can be estimated by:

$$\kappa = k_h \frac{\mu}{\gamma_w} \quad \text{Equation D-6-E-8}$$

Where:

- μ = Dynamic viscosity of water ($N \cdot s/m^2$)
- k_h = Permeability of the piping layer in the horizontal direction (m/sec)

Van Beek et al. (2012) adapted Sellmeijer's (1988) piping rule to multi-layer foundations to assess the influence of a coarse layer beneath the piping layer. The intrinsic permeability in the above equation is replaced with a layer-weighted average calculated as follows:

$$k_{h,avg} = \sum_{i=1}^n \frac{k_{h,i} D_i}{D} \quad \text{Equation D-6-E-9}$$

Where:

- D = Total aquifer thickness

Geometrical Shape Factor

The geometrical shape factor (F_G) is calculated as:

$$F_G = 0.91 \left(\frac{D}{L} \right)^{\frac{0.28}{2.8} + 0.04} \quad \text{Equation D-6-E-10}$$

Where

- D = Thickness of the piping layer (m)
- L = Seepage path length (m) through the piping layer (measured horizontally)

Schmertmann (2000)

Schmertmann (2000) carried out BEP tests in flumes at the University of Florida. The tests were carried out on a range of soils from fine to medium sands, up to coarse sand and fine gravel mixes. The soils were mostly fairly uniform ($1.5 \leq c_u \leq 6.1$). He also plotted the Delft tests and found a similar correlation. Since the test geometries used at University of Florida and Delft were not the same, correction factors for geometry were applied in order to plot all of the results together. *The methodology requires quite large corrections for scale effects and foundation geometry and applies to 2D seepage with plane or ditch exits parallel to the embankment centerline.*

Laboratory Horizontal Critical Gradient

Schmertmann (2000) provided a linear relationship for estimating the horizontal critical gradient as a function of coefficient of uniformity based on study averages from flume tests. Robbins and Sharp (2016) examined the individual test results from each experimental series and provided the best-fit median (50th percentile) relationship shown on figure D-6-E-4. Schmertmann's original relationships is labeled as the "no-test default line" in this figure and represents a lower bound than an average trend for low coefficients of uniformity ($c_u < 3$), which are of primary interest for backward erosion piping. For larger values of coefficient of uniformity, there is considerably more scatter in the data.

Several corrections for a number of factors are applied to the laboratory horizontal critical gradient to obtain the field horizontal critical gradient:

$$i_{po} = \left(\frac{C_D C_L C_S C_K C_\gamma C_Z}{C_R} \right) i_{pmt} \quad \text{Equation D-6-E-11}$$

Appendix D-6-E Critical Gradients for Evaluation of Backward Erosion Piping

Where:

C_D = Correction factor for depth/length ratio

C_L = Correction factor for total pipe length

C_S = Correction factor for grain-size

C_K = Correction factor for anisotropic permeability of layer subject to backward erosion

C_γ = Correction factor for density

C_Z = Correction factor for high-permeability underlayer

C_R = Correction factor for dam axis curvature

i_{pmt} = Maximum point seepage

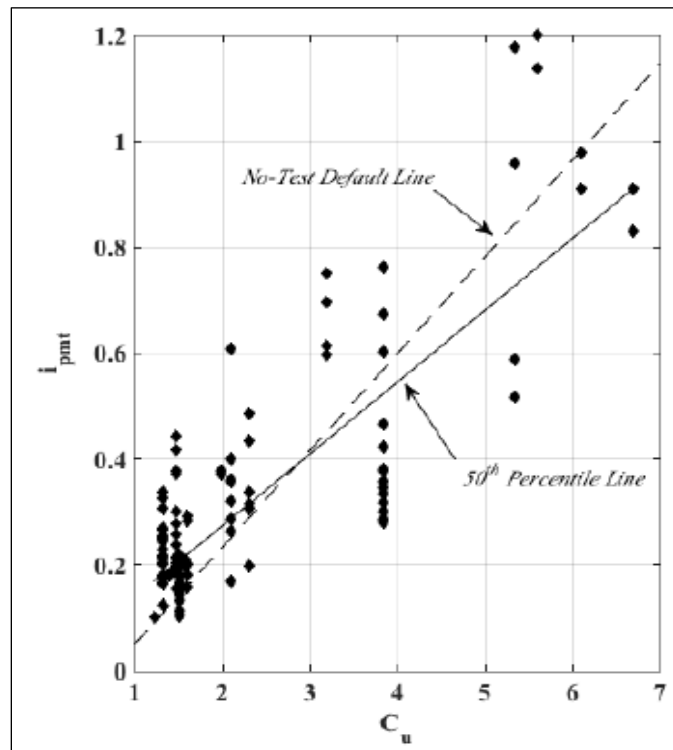

Figure D-6-E-4.—Critical point gradients and best-fit median line (Robbins and Sharp 2016).

gradient needed for complete piping in the flume test based on the soil's coefficient of uniformity from figure D-6-E-4 (additional information about the correction factors is provided below). *Some errors contained in Schmertmann (2000) were corrected.*

Appendix D-6-E Critical Gradients for Evaluation of Backward Erosion Piping

The laboratory testing essentially used clean sands. No sands with silty fines and no sand-gravel mixtures were apparently used. These materials could behave differently than the limited range of sands that were used in the flume tests. In addition, controlled laboratory testing may not adequately account for actual field variability, and the large number of correction factors that are applied for field conditions suggest the tests may not adequately cover cases encountered in the field. *Careful evaluation of the appropriateness of the method for a specific dam or levee is needed.*

Depth/Length Ratio Factor

The D/L_f factor (C_D) can be determined from figure D-6-E-5, where D = thickness of the piping layer measured perpendicular to the flow lines (i.e., perpendicular to pipe inclination, α); and L_f = direct (not meandered) length between ends of a completed pipe path, from downstream to upstream exit, measured along the pipe path on a transformed section. For a vertical flow path, $D/L_f = \infty$ and $C_D = 0.715$. For horizontal flow paths, D = the vertical thickness of the piping layer. For steeply inclined flow paths, interpolate between these limits. Schmertmann (2000) amended the Weijers and Sellmeijer (1993) theory to obtain the relationship for the D/L_f factor shown on figure D-6-E-5 and calculated as:

$$C_D = \frac{\left(\frac{D}{L_f}\right)^{\frac{0.2}{L_f}} \left(\frac{D}{L_f}\right)^{-1}}{1.4} \quad \text{Equation D-6-E-12}$$

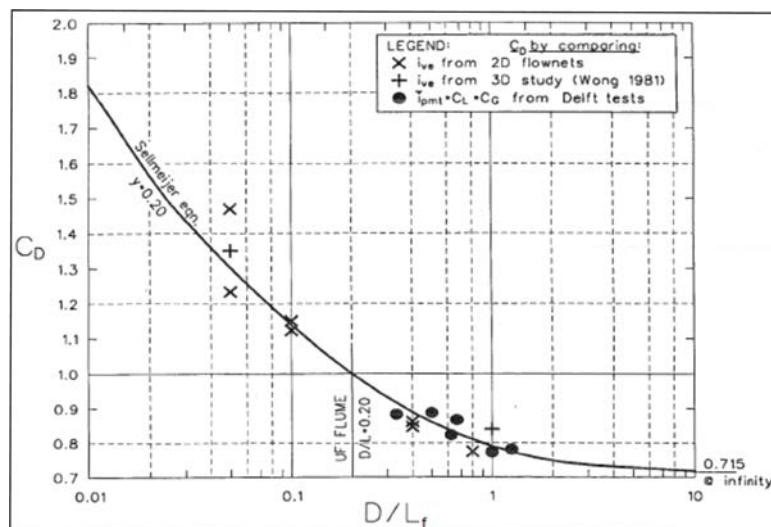

Figure D-6-E-5.—Correction factor for depth/length ratio (Schmertmann 2000)

Length Factor

The length factor (C_L) is calculated as:

$$C_D = \frac{\left(\frac{D}{L_f}\right)^{\frac{0.2}{L_f}}}{1.4} \quad \text{Equation D-6-E-13}$$

where L_t = flume model length ($L_t = 5$ feet if figure D-6-E-4 is being used to estimate i_{pmt}), where

$$L_f = \frac{L}{\left(\frac{k_h}{k_v}\right)^{0.5}} \quad \text{Equation D-6-E-14}$$

Where:

- k_h = Permeability of the piping layer in the horizontal direction
- k_v = Permeability of the piping layer in the vertical direction
- L = Direct (not meandered) length (feet) between ends of a completed pipe path, from downstream to upstream exit, measured along the pipe path

Grain-Size Factor

The grain-size factor (C_S) is calculated as:

$$C_S = \left(\frac{d_{10f}}{0.20 \text{ mm}}\right)^{0.2} \quad \text{Equation D-6-E-15}$$

Where:

- d_{10f} = Particle size (mm) of the (field) piping layer for which 10 percent of the total weight is finer

Anisotropic Permeability Factor

The anisotropic permeability factor (C_K) is calculated as:

$$C_K = \left(\frac{1.5}{R_{kf}}\right)^{0.5} \quad \text{Equation D-6-E-16}$$

Appendix D-6-E Critical Gradients for Evaluation of Backward Erosion Piping

Where:

R_{kf} = Anisotropy of the piping layer (k_h/k_v)

Density Factor

The density factor (C_γ) is calculated as:

$$C_\gamma = 1 + 0.4 \left(\frac{D_{rf}}{100} - 0.6 \right) \quad \text{Equation D-6-E-17}$$

where D_{rf} = relative density of soil layer subject to backward erosion.

Underlayer Factor

If the layer susceptible to piping is underlain by a high-permeability underlayer, figure D-6-E-6 is used to determine the underlayer factor (C_z), where D = thickness of the underlayer (feet); k_p = permeability of the piping layer; k_u = permeability of the underlayer; and r = equivalent radius (feet) of the developing pipe cross section (prior to gross enlargement). Schmertmann used small radii in his tests (0.3 inch and 0.6 inch). For practical purposes, r is very small, and D/r is very large, so it is suggested that $C_z = 1$. If very thin erodible layers are being considered, use radii of 2.5 to 10 cm. For thin alternating layers of erodible and non-erodible soil modeled as a homogenous layer with high anisotropy, use $C_z = 1$.

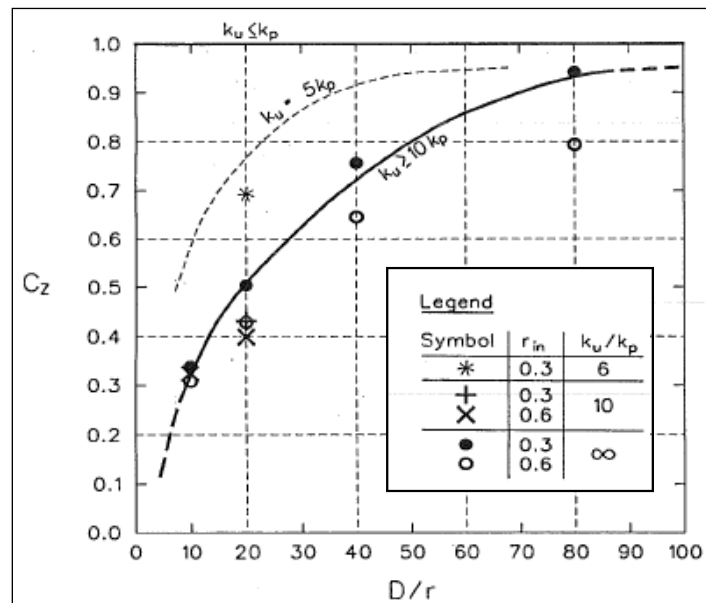

Figure D-6-E-6.—Correction factor for high-permeability underlayer (Schmertmann 2000).

Gradient Factor for Convergent/Divergent Flow

The correction factor for dam axis curvature (C_R) is calculated as:

$$C_R = 1.0 \text{ for a straight dam alignment} \quad \text{Equation D-6-E-18}$$

Or

$$C_R = \frac{R_1 + R_0}{2R} \text{ for a curved dam axis} \quad \text{Equation D-6-E-19}$$

Where:

- R = Radius to point on the pipe path in a dam with curved axis (i.e., radius of curvature in the dam)
- R₀ = Shortest radius to an end of completed pipe path (i.e., distance from the center of curvature to the upstream toe)
- R₁ = Longest radius to an end of completed pipe path (i.e., distance from the center of curvature to the downstream toe)

Pipe Inclination Adjustment

The field horizontal critical gradient is then adjusted for pipe inclination using the pipe inclination adjustment (C_α) which is calculated as:

$$C_\alpha = \frac{i_{p\alpha}}{i_{p0}} \quad \text{Equation D-6-E-20}$$

where $i_{p\alpha}$ = field critical gradient for the angle (α) of the advancing pipe path (towards the impounded water) from Figure D-6-E-7. If the pipe path progresses upward, α is positive, whereas α is negative if the pipe path progresses downward. For a horizontal seepage exit $\alpha = 0$ degrees, and for a vertical seepage exit $\alpha = -90$ degrees. Figure D-6-E-8 can be used as a guide for determination of the sign for α .

Field Critical Gradient for Progression of the Pipe

The field critical gradient for progression of the pipe is then obtained by applying the pipe inclination adjustment to the field horizontal critical gradient:

$$i_{adv} = i_{p0} C_\alpha \quad \text{Equation D-6-E-21}$$

Appendix D-6-E Critical Gradients for Evaluation of Backward Erosion Piping

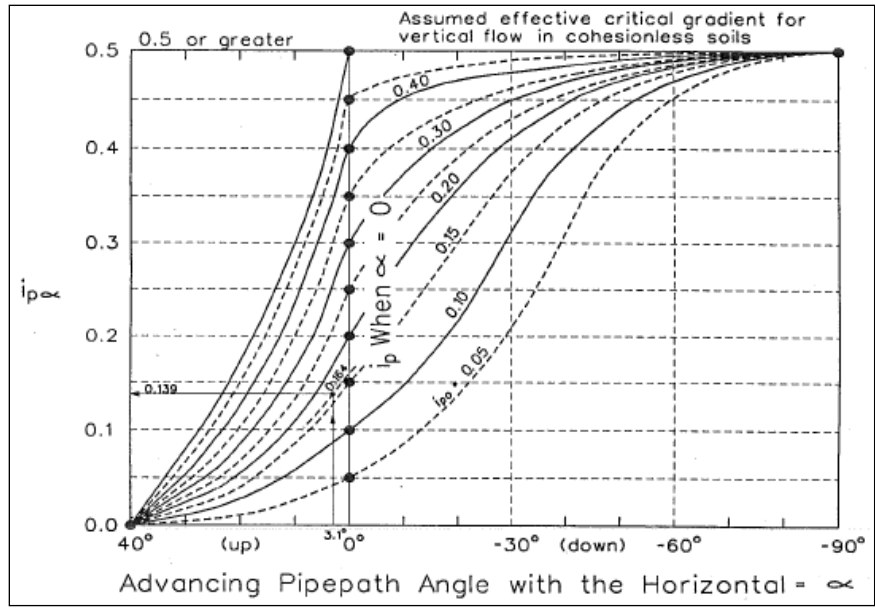

Figure D-6-E-7.—Field critical gradient (Schmertmann 2000).

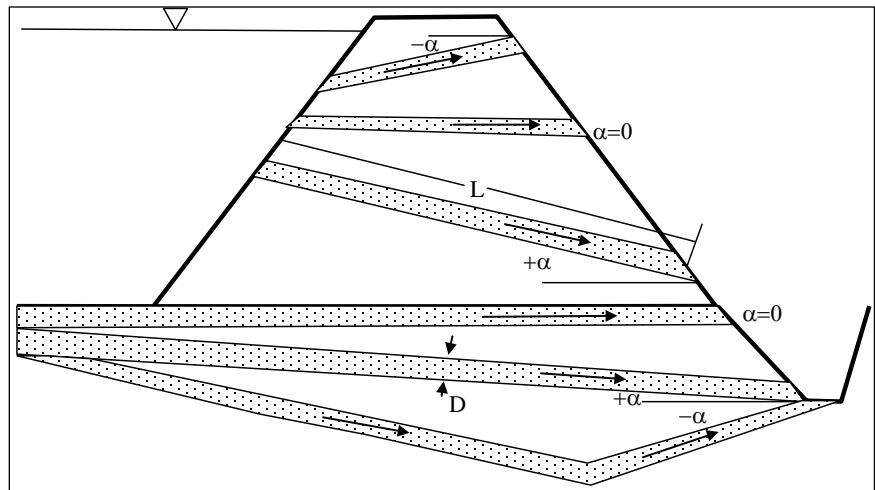

Figure D-6-E-8.—Pipe path inclination geometry.

Hydraulic Condition for Progression of a Pipe

To assess the likelihood of progression of a pipe (hydraulic condition), the average gradient for the reservoir level under consideration is compared to the critical gradient for progression of a pipe. An example of portrayal of analytical results for multiple methods is shown on figure D-6-E-9. In this example, the critical gradient for progression of a pipe was evaluated using four methods. Based on the estimated average gradient (hydraulic head difference divided by the seepage path length), this figure can be used to help develop a list of more likely

Appendix D-6-E Critical Gradients for Evaluation of Backward Erosion Piping

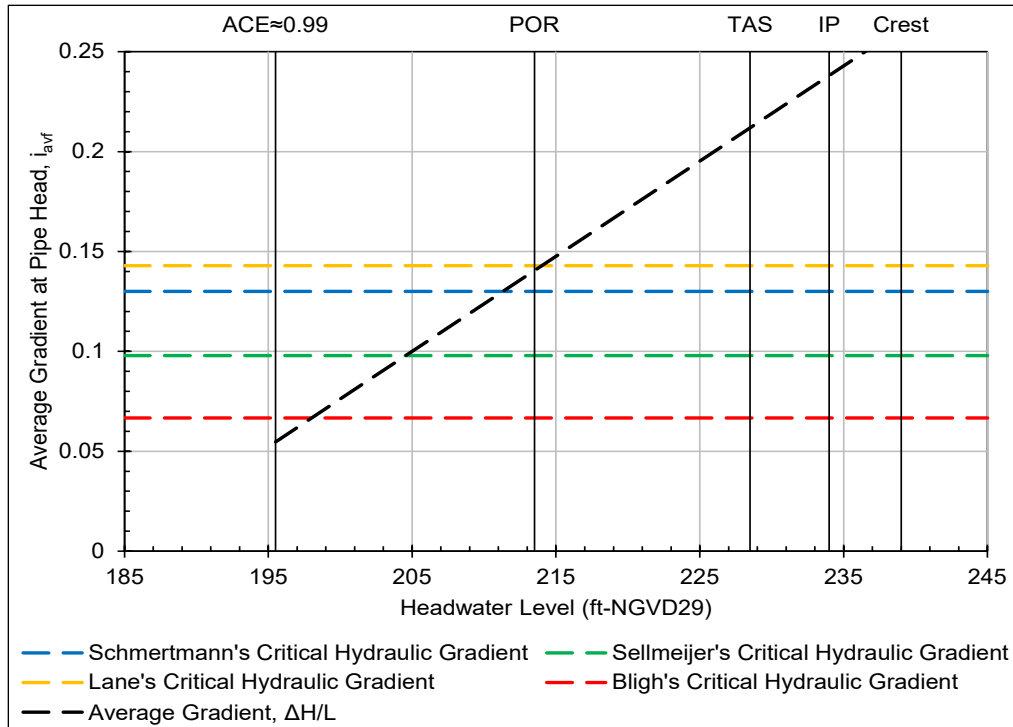

Figure D-6-E-9.—Sample portrayal of analytical results for progression of a pipe.

and less likely factors for the hydraulic condition for progression of BEP as a function of reservoir level. The methods shown may not be given equal weight by the risk team in assessing the probability.

Likelihood of Progression of a Pipe (Hydraulic Condition)

Sensitivity or uncertainty analysis is recommended. In addition to a best estimate, a range of values should be considered from a reasonable low estimate to a reasonable high estimate. Probability distributions can also be assigned for the various input parameters to be used in a Monte Carlo simulation to assess the probability of a factor of safety against progression of the pipe (hydraulic condition).

Robbins and Sharp (2016) presented the results of a best-fit quantile regression analysis from the individual laboratory flume tests. Figure D-6-E-10 can be used to develop a cumulative density function to estimate the probability of BEP progressing. An example of portrayal of analytical results obtained using the Robbins and Sharp best-fit quantile regression lines is shown on figure D-6-E-11. Analytical results should be used to help to help inform judgment and develop a list of more likely and less likely factors during an elicitation to develop actual probabilities with due consideration for uncertainty.

Appendix D-6-E Critical Gradients for Evaluation of Backward Erosion Piping

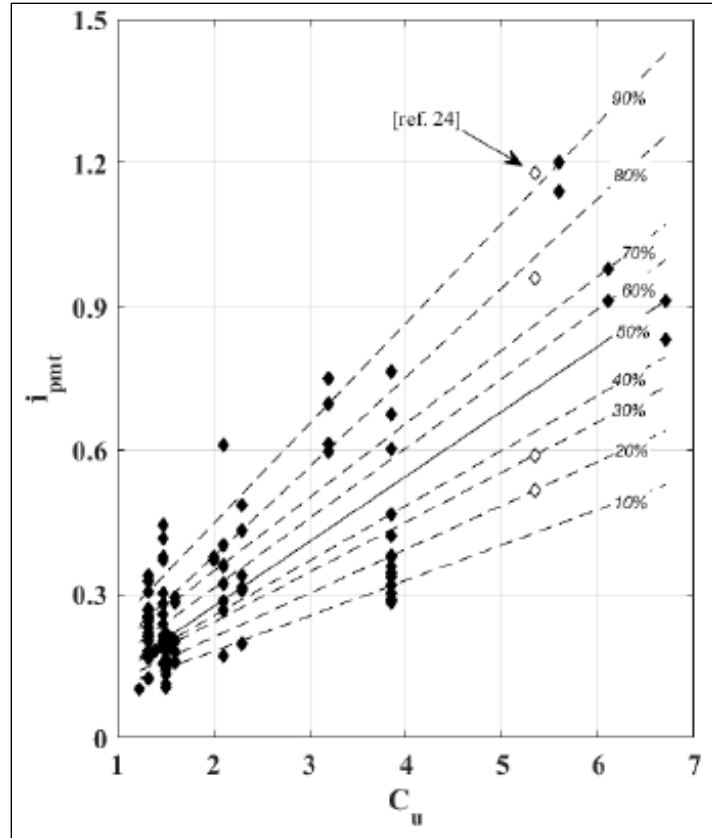

Figure D-6-E-10.—Critical point gradients and best-fit quantile regression lines (Robbins and Sharp 2016).

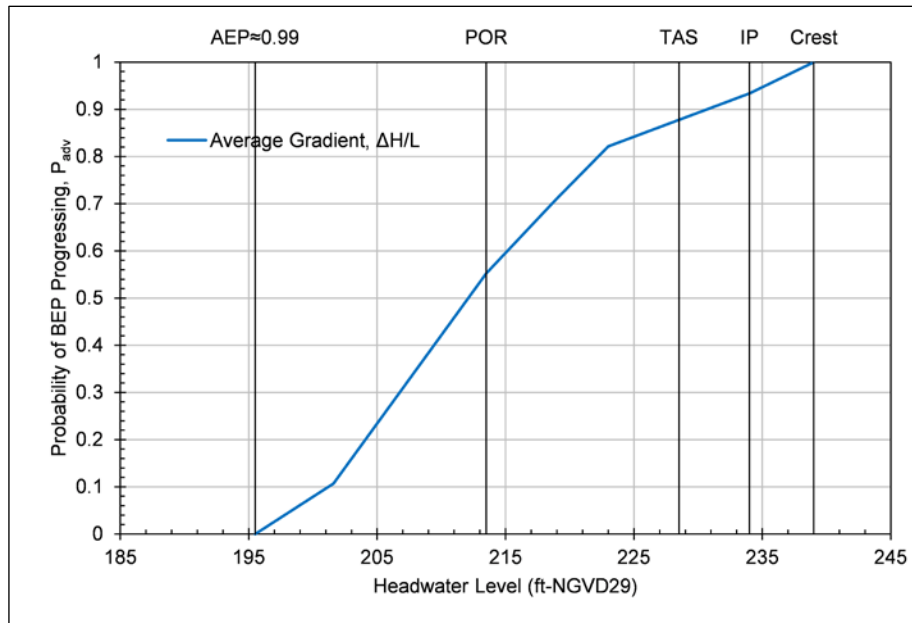

Figure D-6-E-11.—Sample portrayal of analytical results for likelihood of progression of a pipe (hydraulic condition).

APPENDIX D-6-F

Internal Instability (Suffusion)

Geometric Condition (Detailed Evaluation of Susceptibility)

If the screening-level review of the gradation curves indicates the soil is potentially internally unstable, then the more robust methods in in this appendix may be applied to further evaluate the susceptibility to internal instability.

Several methods are described, and some methods may not apply to the materials under consideration. Multiple methods are suggested to help inform judgment. Marot et al. (2014) made the following suggestions for assessing the geometric criteria:

Hydraulic Condition

There is little published literature on the seepage gradient required to initiate suffusion. Skempton and Brogan (1994) investigated the hydraulic criterion for the erosion of fine particles in well-graded and gap-graded sandy gravels and observed critical hydraulic gradients far less than the theoretical critical gradient for “heave.”

Fell et al. (2004) summarized some general observations from laboratory testing:

- Soils with a higher porosity start to erode at lower hydraulic gradients.
- Soils with clayey fines erode at relatively higher hydraulic gradients than soils without clayey fines at similar fines contents.
- Soils with higher soil density erode at higher critical gradients, given the fines content of the soils are the same.
- Gap-graded soils erode at a relatively lower critical gradients than non-gap-graded soils with similar fines content.

According to Marot et al. (2014), the hydraulic loading on the particles is often described by three different approaches:

- Hydraulic gradient: Skempton and Brogan (1994) and Li (2008)
- Hydraulic shear stress: Reddi et al. (2000)
- Pore velocity: Marot et al. (2011, 2012)

However, more research is needed with a wider range of soils, hydraulic gradients, and flow orientation. In many of the internally stable soils tested in the laboratory, the gradients required to initiate suffusion were so high that they are unlikely to occur in dams, levees, or their foundations.

Appendix D-6-F Internal Instability (Suffusion)

Burenkova (1993)

Based on the results of laboratory testing on cohesionless sand-gravel soils with maximum particle sizes up to 100 mm and coefficients of uniformity up to 200, Burenkova (1993) proposed a geometric condition for internal stability of a soil that depends on the conditional factors of uniformity ($h' = d_{90}/d_{60}$ and $h'' = d_{90}/d_{15}$) as shown on figure D-6-F-1.

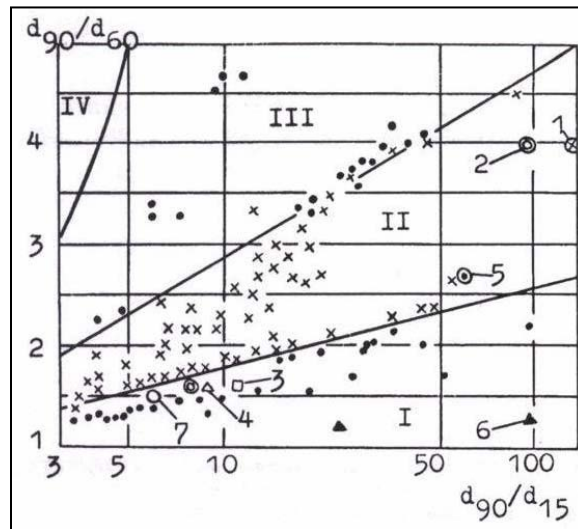

Figure D-6-F-1.—Materials susceptible to internal instability (Burenkova 1993).

Boundaries were defined separating “suffusive soils” from “non-suffusive soils.” Zones I and III represent zones of suffusive compositions; Zone II represents a zone of non-suffusive compositions; and Zone IV represents a zone of artificial soils. Zone II (non-suffusive) boundaries are defined as follows:

$$0.76 \log(h'') + 1 < h' < 1.86 \log(h'') + 1 \quad \text{Equation D-6-F-1}$$

Wan and Fell (2004a, 2008)

According to Wan and Fell (2004a, 2008), the Burenkova (1993) method did not give a clear boundary between internally stable and unstable soils in the data set. Therefore, they developed contours for predicting the probability of internal instability by logistic regression of h' and h'' . Their “modified Burenkova method” for broadly graded and gap-graded soils is shown on figure D-6-F-2 for silt-sand-gravel and clay-silt-sand-gravel mixtures of limited plasticity and clay content (i.e., $PI \leq 12$ and less than 10 percent clay-size fraction, defined as the percentage finer than 0.002 mm) and figure D-6-F-3 for sand-gravel mixtures with a non-plastic $FC < 10$ percent. The contours on figure D-6-F-3 predict higher probabilities of internal instability than those on figure D-6-F-2 because

Appendix D-6-F Internal Instability (Suffusion)

the more erosion resistant clayey and silty soil samples were excluded from the data set. The probability contours are represented by the following equations (Wan and Fell 2004a):

$$P_I = \frac{e^Z}{1 + e^Z} \quad \text{Equation D-6-F-2}$$

For silt-sand-gravel soils and clay-silt-sand-gravel soils percent of limited clay content and plasticity,

$$Z = 2.378 \log(h'') - 3.648h' + 3.701 \quad \text{Equation D-6-F-3}$$

For sand-gravel soils with less than 10 percent non-plastic fines,

$$Z = 3.875 \log(h'') - 3.591h' + 2.436 \quad \text{Equation D-6-F-4}$$

The probabilities should not be used directly in a risk assessment, but rather used to help develop a list of more likely and less likely factors during an elicitation of probability estimates.

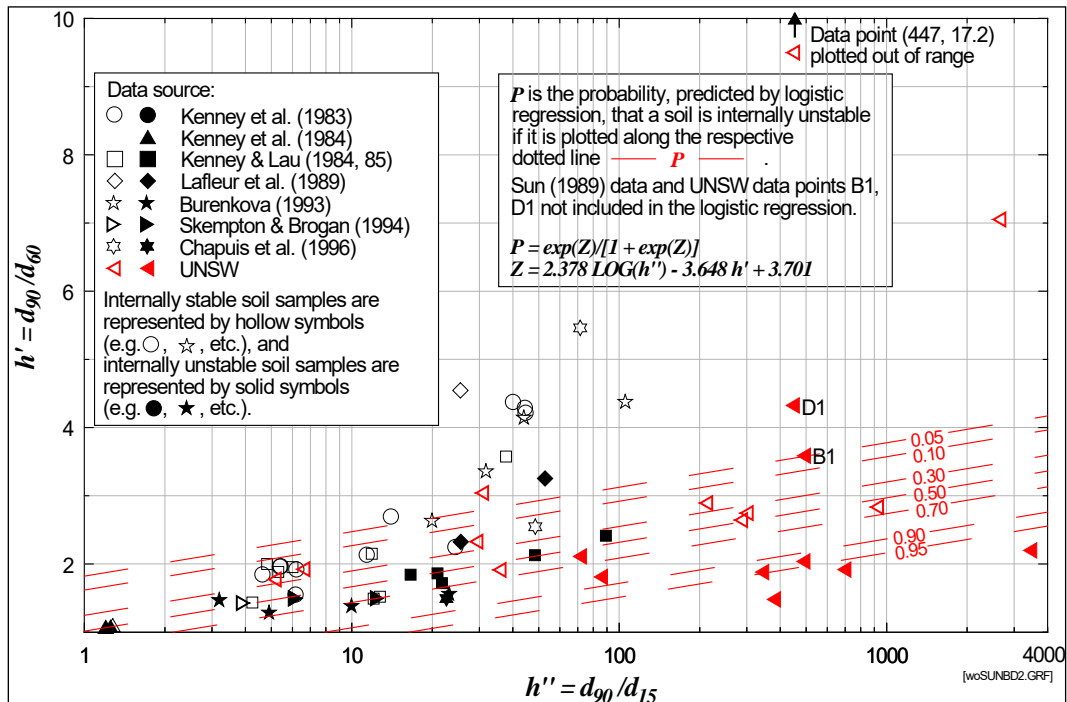

Figure D-6-F-2.—Probability of internal instability for silt-sand-gravel soils and clay-silt-sand-gravel soils of limited clay content and plasticity (Wan and Fell 2004a).

Appendix D-6-F Internal Instability (Suffusion)

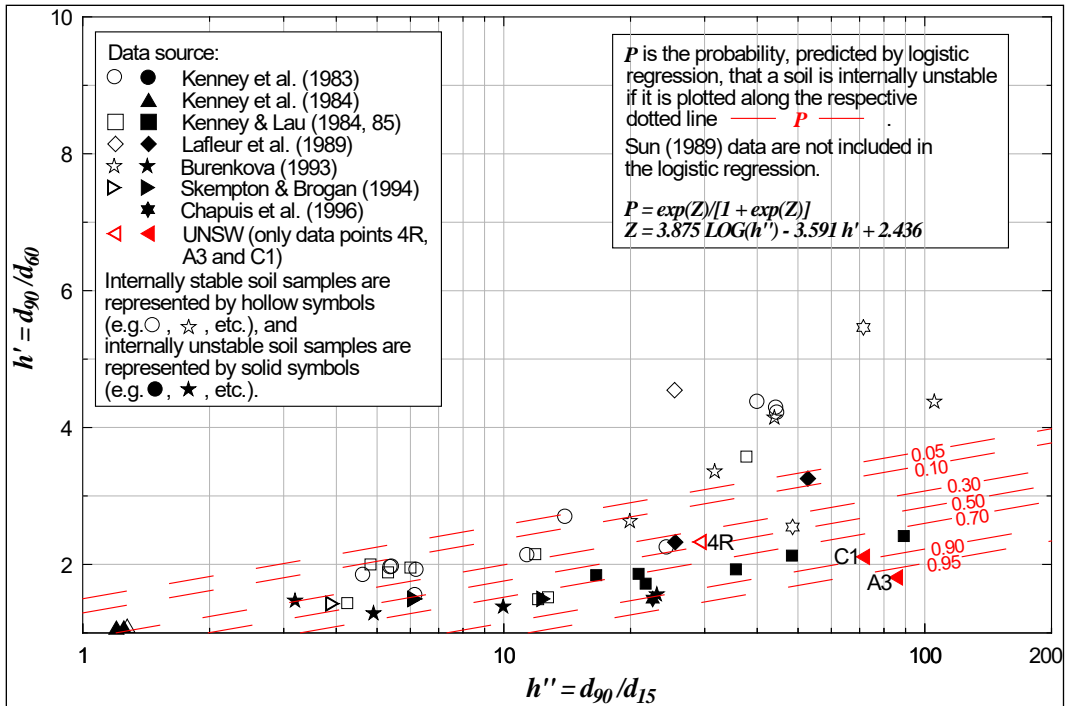

Figure D-6-F-3.—Probability of internal instability for sand-gravel soils (Wan and Fell 2004a).

Wan and Fell (2008)

Wan and Fell (2008) also proposed an alternative method for broadly graded silt-sand-gravel soils as a function of d_{90}/d_{60} and d_{20}/d_5 . Boundaries shown on figure D-6-F-4 were proposed for likelihood of internal instability. This method is not applicable to gap-graded soils.

Li and Fannin (2008) reviewed two commonly used methods to determine the susceptibility to internal instability: Kézdi (1979) and Kenney and Lau (1985, 1986). Kézdi divided a soil into a coarse fraction and a fine fraction at one point along its particle-size distribution curve and applied Terzaghi's (1939) rule for designing protective filters (D'_{15}/d'_{85}) to the two fractions, with the fine fraction as the "base" and the coarse fraction as the "filter," to assess if the soil would self-filter and be internally stable. The mass increment (H) over D'_{15} and d'_{85} is constant and equal to 15 percent, resulting in a criterion for instability of H less than 15 percent.

Kenney and Lau calculated an H/F stability index over the increment D to $4D$, which increases in magnitude with progression along the gradation curve, where H is the mass fraction between D and $4D$ and F is the mass passing. They originally proposed a criterion in 1985 for internal instability of $H/F < 1.3$, applicable within $F \leq 30$ percent (and $c_u \leq 3$) for narrowly graded soils and within

Appendix D-6-F Internal Instability (Suffusion)

$F \leq 20$ percent (and $c_u > 3$) for widely graded soils. This criterion was subsequently revised in 1986 to $H/F < 1.0$. This method is commonly used for cohesionless sand-gravel soils (e.g., Reclamation's "4x" line).

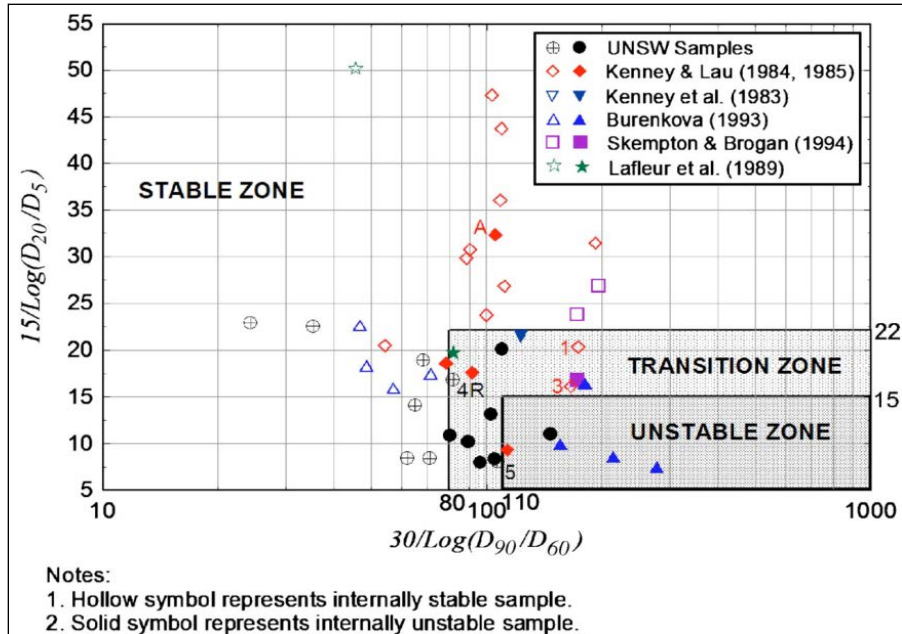

Figure D-6-F-4.—Alternative method for assessing internal instability (Wan and Fell 2008; Li and Fannin 2008).

An example of converting a particle-size distribution curve to H-F space (referred to as the "shape curve") is shown on figure D-6-F-5.

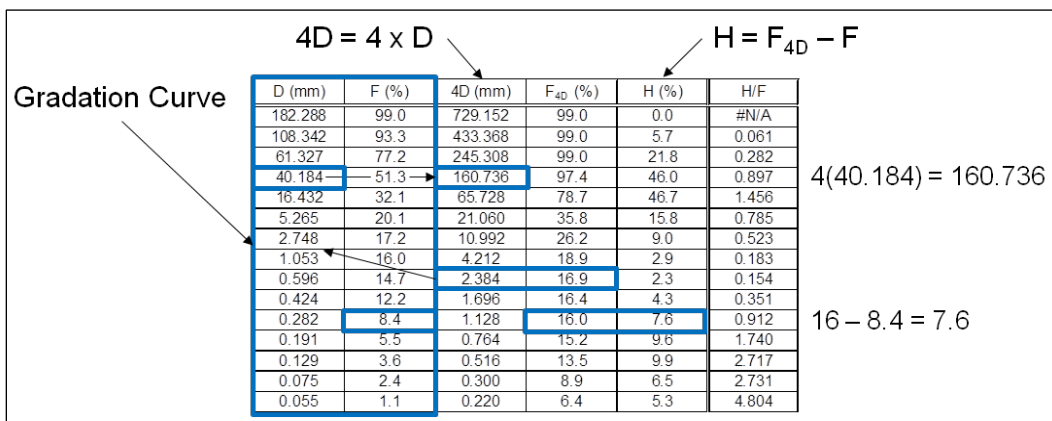

Figure D-6-F-5.—Example of obtaining the shape curve.

Appendix D-6-F Internal Instability (Suffusion)

Li and Fannin (2008) combined aspects of these two methods for assessing the susceptibility to internal instability. They concluded that the Kenney and Lau criterion is more conservative at $F > 15$ percent, but the Kézdi criterion is more conservative at $F < 15$ percent. The combined criteria are shown on figure D-6-F-6, where the respective values of H and F are plotted at $(H/F)_{min}$.

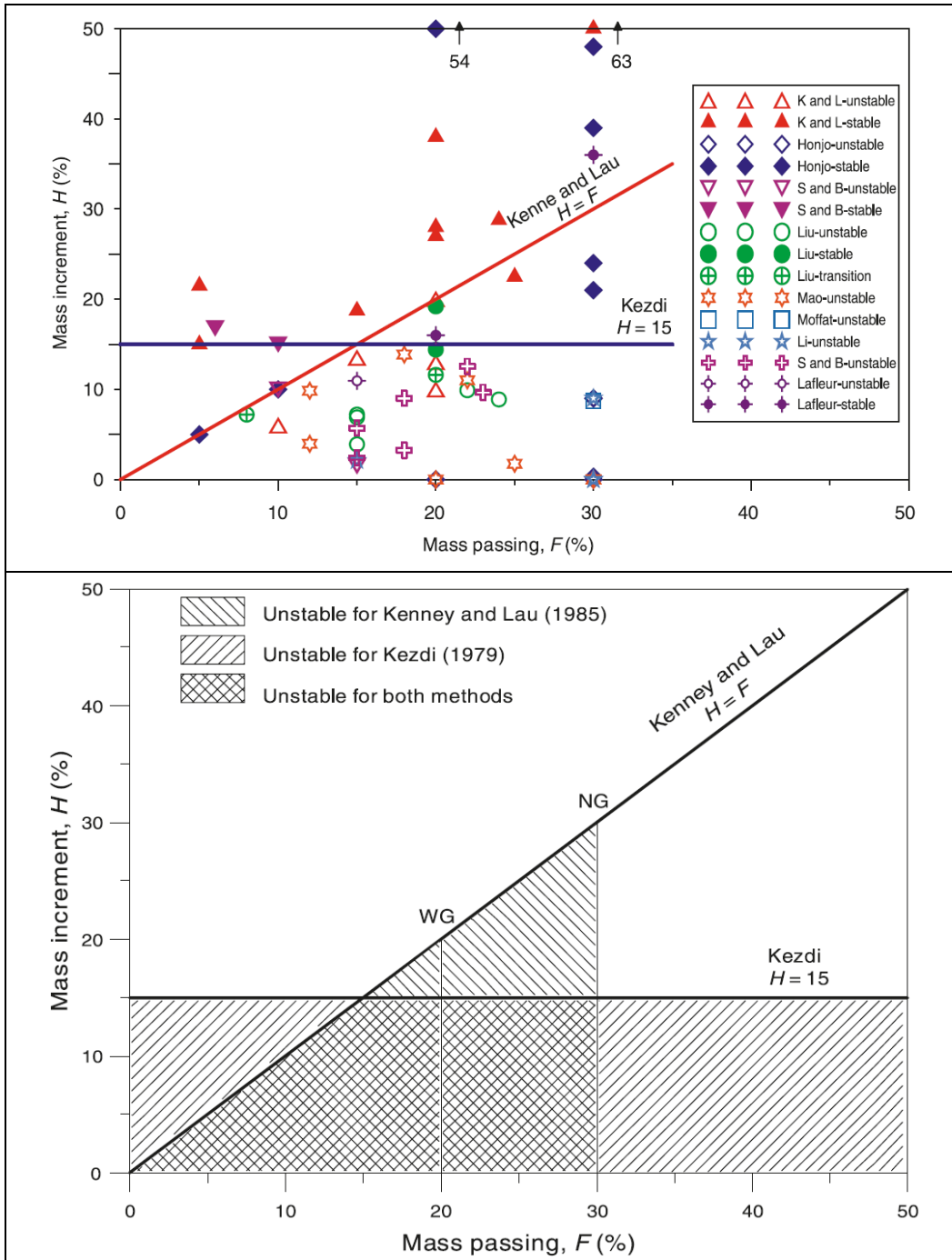

Figure D-6-F-6.—Criteria for internal instability (Li and Fannin 2008).

APPENDIX D-6-G

Detailed List of Conditions which Increase the Likelihood of
Initiation of an Internal Erosion Process

In consideration of Fell et al (2008), the following is a detailed list of conditions that increase the likelihood of initiation of the various processes of internal erosion. Combinations of some of these conditions are common in case histories of incidents involving internal erosion and should be considered where appropriate.

Leads to Increased Likelihood of Scour

Through the embankment

- Cracking of embankment from differential settlement of fill:
 - Wide benches or “stair steps” in the upper to middle portion of the abutment profile.
 - Steep abutments near the top of the embankment.
 - Very steep abutments and a narrow valley can lead to “arching” of the soil across the valley leading to a reduction in vertical confining stress within the embankment and increased potential for hydraulic fracturing (i.e., pore pressures exceed confining stress).
 - Fell et al. (2008) suggest that differential settlement between the shell and the core (if deformability of the materials differ) can lead to “dragging and transverse shearing” of the core. However, more typically, this type of differential settlement leads to longitudinal cracks at the interface between the two materials. The core, if more deformable than the shells, can get “hung up” leading to transverse near horizontal low stress zones and cracking through the core.
 - Seasonal shut-downs or placement in freezing weather can lead to a pervious layer through the core if not properly treated (i.e., frozen material and desiccation cracking was not removed, and the surface thoroughly scarified with good moisture control upon re-compaction). In the unlikely event that post-shutdown construction results in lower modulus material in comparison to the underlying embankment, differential settlement of the overlying embankment can lead to transverse cracking.
 - Desiccation of the embankment material in upper part of the core or at a shutdown.

Appendix D-6-G Detailed List of Conditions Which Increase the Likelihood of Initiation of an Internal Erosion Process

- Excessive settlements as a percentage of the embankment height (i.e., more than about 3 to 5 percent during construction or about 1 percent at 10 years post-construction) increases the chances of transverse cracking – even lesser settlements may lead to cracking in particularly brittle soils. Note that cracking is often masked; case histories suggest that such cracking can go unnoticed for years and even decades.
- Poor core density due to lack of formal compaction, lack of compaction control, or excessively thick compacted layers can result in cracks or defective layers through the core.
- Cracking of embankment due to differential settlement seated in foundation:
 - Different foundation conditions (deformability) across the profile.
 - A narrow steep-walled cutoff trench forms a location where arching of core material placed into the trench can lead to a low-density zone in the core susceptible to transverse hydraulic fracturing.
 - Low-density fine-grained loess soils or weakly cemented “desert” soils present within the foundation may collapse upon wetting. These conditions could lead to coincident cracks in foundation soils.
 - Different deformability conditions between fill and foundation soils (such as at diversion channels).
 - Excessive settlements as a percentage of the embankment height (i.e., more than about 3 to 5 percent during construction or about 1 percent at 10 years post-construction) increases the chances of transverse cracking – even lesser settlements may lead to cracking in particularly brittle soils. Note that cracking is often masked; case histories suggest that such cracking can go unnoticed for years and even decades.
 - An irregular foundation contact surface, possibly with overhanging rock features, or sloppy or loose foundation soil conditions upon embankment placement.
 - Irregular rock surfaces and overhangs beneath foundation soils that are not cutoff can cause differential settlement and/or defects beneath overhangs.

Appendix D-6-G Detailed List of Conditions Which Increase the Likelihood of Initiation of an Internal Erosion Process

Through the foundation

- Soil filled joints. Silt and fine sand deposits against openwork gravels.

From the embankment into the foundation

- Open joints, seams, faults, shears, bedding planes, solution features, or other discontinuities at contact with rock foundation. Silt embankment constructed directly upon openwork gravel.
- Ridges and valleys formed by excavation along geologic features (e.g., tilted bedding planes forming an irregular surface) that trend upstream to downstream, into which compaction is difficult, can lead to cracks/flaws pathways near the embankment-rock contact and hydraulic fracture (Quail Creek Dike, Utah).
- Open joints, seams, faults, shears, bedding planes, solution features, or other discontinuities in the rock foundation at the contact with the embankment core into which core material can erode, especially if the following also apply:
 - The discontinuities trend upstream to downstream across the foundation, providing a pathway for reservoir seepage.
 - There was no or questionable foundation surface treatment performed during construction in the way of dental concrete or slush grout, especially if the treatment area was narrow with respect to the height of the embankment.
 - The effectiveness of foundation grouting is questionable due to grout holes being parallel to open discontinuities, poor grout mixes, widely-spaced holes with uncertain closure, uncaulked surface leaks during grouting, and/or little pore-pressure drop across the grout curtain as measured by piezometers.
 - The discontinuities are open, or perhaps filled with erodible silty or sandy material. Wider discontinuities are more problematic than narrow ones.
- Poor clean-up at the core-foundation rock surface can lead to a flaw.
- Highly permeable gravel foundation materials which can transmit significant flow capable of eroding material at the base of the embankment and carrying it downstream.

Appendix D-6-G Detailed List of Conditions Which Increase the Likelihood of Initiation of an Internal Erosion Process

Associated with structures

A conduit through the embankment can create a potential crack due to the potential for inadequate density or compaction, especially if one or more of the following conditions are also present:

- A round conduit with no concrete encasement resulting in poor compaction.
- The presence of seepage cutoff collars.
- Cracks or open joints in the conduit, or corrugated metal pipe which is subject to corrosion deterioration and through-going holes.
- Steep and narrow trench into which the conduit was placed, which makes compaction difficult and creates the potential for arching of soil across the trench, leaving a low-density zone susceptible to hydraulic fracturing.
- A stiff conduit projecting up into a brittle embankment.
- An outlet conduit trench forms a location where arching of core material placed into the trench can lead to a low-density zone in the core susceptible to transverse hydraulic fracturing.
- Presence of frost-susceptible soils in which ice lenses can form, particularly when these materials are adjacent to conduits or other structures that could increase the possibility of freezing conditions.
- Against a spillway wall, due to difficulties in compacting against the wall (especially if vertical or counterforted), settlement away from the wall parallel to the abutment, can potentially lead to a high permeability zone or small gap adjacent to the wall.
- For composite concrete/embankment dams, vertical faces, overhangs, and changes in slopes of the concrete section (against which the embankment core is compacted) can lead to cracks/flaws especially if post-construction embankment settlements are large.
- Direct observations such as observed transverse cracks or settlement of fill adjacent to structures.
- Concentrated seepage or wet areas on the downstream face of the embankment, adjacent to a structure be indications that flow may extend through the embankment.

Leads to Increased Likelihood of Internal Migration

Through or in embankment

- Broadly graded core placed in contact with coarse grained fill. Typically happens along a steep contact.
- Evidence of sinkholes or depressions (especially along the alignment of a penetrating outlet works conduit), could be indications that material has moved by means of seepage flows.

Through the foundation

- Fine-grained soils over coarse grained open work soils – such as reservoir sediment over glacial outwash gravels.

From the embankment into the foundation

- Untreated open joints, seams, etc. in foundation rock overlain by non-cohesive embankment fill.
- Open joints, seams, faults, shears, bedding planes, solution features, or other discontinuities in the rock foundation at the contact with the embankment into which fill can drop into or be eroded down into.

Along or into structures

- Damaged conduit overlain by non-cohesive fill.

Into drains

- Broken drain pipes or inadequately designed drain systems overlain by non-cohesive embankment fill.

Leads to Increased Likelihood of Backwards Erosion Piping

Through the embankment

- Severe filter incompatibility at core contact with shell.
- Rodent holes and root balls, if not properly treated, can be locations for piping to initiate. Rodents may burrow into dry areas of an embankment

Appendix D-6-G Detailed List of Conditions Which Increase the Likelihood of Initiation of an Internal Erosion Process

when the reservoir is low, but these areas may be exposed to the reservoir as it rises. Similarly, decaying root systems can form pathways for piping initiation.

Through the foundation

- Continuous fine sand deposits, natural impervious blanket overlying fine sands hydraulically connected to river or reservoir.
- A low permeability confining layer at the toe of the embankment beneath which high artesian pressures exist, which increases the chance of blowout.
- Sand boils observed in the channel downstream of the embankment which could be indications of material movement associated with a foundation seepage path, especially if material is moving out away from the boils.

From the embankment into the foundation

- Core material placed directly against gravels in bottom of downstream side of cutoff trench.
- Embankment core material placed against the downstream slope of a cutoff trench cut into pervious gravels with no intervening filter leaves an interface through which core material can be eroded.
- Along or into structures.—damaged conduit surrounded with non-cohesive embankment or founded upon fine sands or silts.

Into embankment drains or structural drains

- Damaged or unfiltered drain pipe at downstream end of continuous sand or silt deposits.

Leads to Increased Likelihood of Internal Instability

Through the embankment

- Non-plastic broadly graded core against coarse downstream shell.

Through the foundation

- Gap-graded soil deposits such as some glacial deposits.

APPENDIX D-6-H

Continuation

Susceptibility to Cracking

The ability of a filter material to hold a crack generally depends on the fines content, cementation, or the presence of plastic fines. Filters with low fines content and non-plastic fines are generally less likely to sustain a crack than filters with a high fines content comprised of plastic fines. Criteria have been developed to decrease the amount of fines and thus the chance of a filter cracking and it is important to include these when evaluating an existing filter. For example, Reclamation and USACE filter design criteria require a minimum D_{5F} equal to 0.075 mm (i.e., non-plastic fines content less than or equal to 5 percent) in the final in-place product to help ensure these filters will not hold a crack. To achieve the maximum allowable fines content after compaction, the “off the belt” at the quarry/crusher stockpile typically had about 3 percent fines to account for breakdown during handling, transportation, placing, and compacting. In some circumstances for critical modern designs, the maximum in-place fines content has been limited to 3 percent. Reclamation and USACE filter design criteria also require the portion of the filter material passing the No. 40 (0.425 mm) sieve be non-plastic (i.e., PI = 0). Cementation increases the likelihood of cracking. Typical cementing agents include carbonate materials (e.g., limestone or dolomite), gypsum, sulfide materials, and volcanic (pyroclastic) ash, particularly for sand-sized particles. Even small amounts of silt in broadly graded, silty sandy gravel transition zones or filters may result in cracking. As suggested by Terzaghi and Peck, a dense well-graded transition zone with a slight amount of silt fines can crack. There is some laboratory evidence that thin (less than 5 feet thick), vertical, clean, partially saturated and compacted filters subject to severe cracking may hold a crack, and a gravel zone downstream of a cracked filter allowed for healing of the cracked filter (Redlinger et al. 2011). Table D-6-H-1, which is based on laboratory testing conducted by Park (2003) and field performance data from Foster (1999) and Foster and Fell (1999), provides guidance on assessing the likelihood of a filter material holding a crack. The descriptors should be used to help develop a list of more likely and less likely factors during a team elicitation of probability estimates.

The evaluation for cracking of a filter or transition zone also needs to consider the effect of stress conditions and the presence of flaws or defects in this zone along with consideration of “common causes” for a flaw in the impervious zone. Consideration of “common causes” using the bullet lists of conditions that may lead to an increased likelihood of a **flaw existing through the dam** (including considerations for conduits through the dam), a **flaw through the foundation or from the embankment into the foundation** contained “appendix D-6-G, Detailed List of Conditions which Increase the Likelihood of Initiation of an Internal Erosion Process” should be included.

Appendix D-6-H Continuation

Table D-6-H-1.—Likelihood of a Material Holding a Crack (adapted from Fell et al. 2004)

Plasticity of Fines	Fines Content, FC (percent)	Likelihood of Holding a Crack	
		Well Compacted	Not Compacted
Non-plastic (and no cementing present)	5 to 7	Unlikely	Very Unlikely
	7 to 15	Likely	Unlikely to Likely
	≥ 15	Very Likely	Likely
Plastic (or fines susceptible to cementing)	5 to 7	Likely	Unlikely to Likely
	7 to 15	Very Likely	Likely
	≥ 15	Virtually Certain	Very Likely

Susceptibility to Segregation

Segregation is the tendency of large particles in a given mass of aggregate to gather together whenever the material is being stockpiled, loaded, transported, placed or otherwise disturbed. Segregation of filter material can cause pockets of coarse zones that may not be filter-compatible with the material being protected. For segregation to be a significant contributor to the likelihood of continuation of internal erosion, an entire lift of the filter zone has to be segregated from upstream to downstream, which is very unlikely except for very narrow zones, and the segregated layer has to correspond with a flaw or concentrated seep in the embankment. For narrow filter zones placed upstream to downstream in one pass, it may be necessary to evaluate the potential for segregation. A common cause of segregation is improper material handling. Material placed in a pile off of a conveyor, or loaded from a chute, or from a hopper segregates because the larger particles roll to the sides of the stockpiles or piles within the hauling unit. Material dumped from a truck, front loader, or other placing equipment almost always segregates, with the severity of the segregation corresponding to the height of the drop, moisture content, and the maximum size of the particles. Soils which are susceptible to internal instability are also susceptible to segregation during placement which aggravates the problem as coarse particles become nested in a matrix of finer particles.

Based on laboratory testing, Kenney and Westland (1993) concluded that all dry soils consisting of sands and gravels segregate in the same general way, independent of grain size and grain size distribution. Dry soils containing particle sizes smaller than 0.075 mm segregate to a smaller extent than soils not containing fines, and water in sandy soils (mean size finer than 3 mm to 4 mm) inhibits segregation but has little influence on the segregation of gravels (mean size coarser than 10 to 12 mm). To minimize segregation during construction, Reclamation and USACE filter design criteria, which limits the amount of fines and oversize material, as shown in table D-6-H-2, can be used to help evaluate existing filter/transition zones. Although a minimum D_{5F} size of 0.075 mm may

Appendix D-6-H Continuation

have been specified in the final in-place product, breakdown may occur during placement and compaction. The filter design criteria also limit the maximum allowable D_{90F} size based on the minimum D_{10F} size, as shown in table D-6-H-3.

Table D-6-H-2.—Minimum and Maximum Particle Size Criteria for Filters (adapted from FEMA 2011)

Base Soil Category	Minimum D _{5F}	Maximum D _{100F}
All categories	≥ 0.075 mm (No. 200 sieve)	≤ 2 inches (75 mm)

Note: USACE (2005) sets maximum D_{100F} at 3 inches (75 mm), maximum FC of 5 percent, and PI of zero.

Table D-6-H-3.—Segregation Criteria for Filters (adapted FEMA 2011)

Base Soil Category	If Minimum D _{10F} is: (mm)	Then Maximum D _{90F} is: (mm)
All categories	< 0.5	20
	0.5 – 1.0	25
	1.0 – 2.0	30
	2.0 – 5.0	40
	5.0 – 10	50
	> 10	60

Analytical results should be used to help to help inform judgment and develop a list of more likely and less likely factors during an elicitation to develop actual probabilities with due consideration for uncertainty.

Estimated Gradation after Segregation or Washout

Fell et al. (2008) recommended an approximate method for estimating the D_{15F} of filter materials after segregation or washout that assumes 50 percent of the finer soil fraction is segregated out or 50 percent of the unstable or erodible soil fraction is washed out. However, Fell (2016) indicated that it is more appropriate to assume 100 percent.

Evaluation of Filters (or Adjacent Materials) not Meeting Modern Particle Retention Criteria

Filter zones and adjacent materials which are coarser than required by modern design methods based on particle size will often be quite effective in controlling

Appendix D-6-H Continuation

internal erosion (Foster and Fell 1999, 2001). Downstream rockfill and sand/gravel zones which were not designed as filters may provide some protection against continuation of internal erosion. In addition, foundation soils can also provide some protection against continuation. Depending on the ratio of particle and pore sizes, the erosion will either:

- Not continue (i.e., NE)
- Stop after only minor erosion (i.e., some erosion)
- Stop only after a significant amount of erosion (i.e., EE)
- Continue (i.e., CE)

These erosion filter erosion boundaries are conceptually shown on figure D-6-H-1.

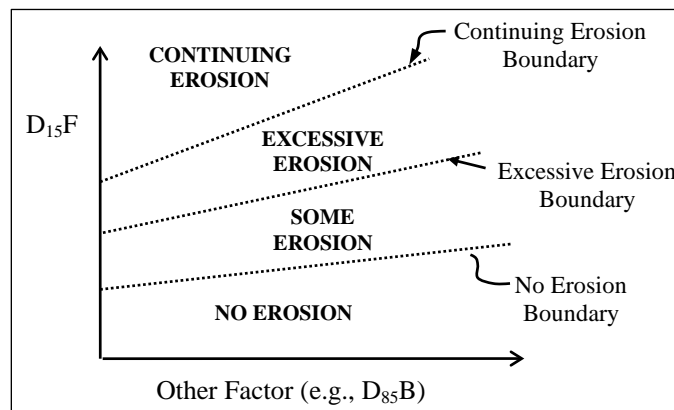

Figure D-6-H-1.—Conceptual filter erosion boundaries (Foster 1999; Foster and Fell 2001).

The filter evaluation relies heavily on the work of Foster and Fell (2001) to determine no erosion, some erosion, excessive erosion, and CE boundaries for the base soil. CE indicates the base soil could be eroded through the filter without plugging off, and this is the primary focus of the evaluation of the likelihood of continuation of internal erosion. Although internal erosion is expected to initiate for some erosion and excessive erosion, it would eventually plug-off, given time under conditions in the laboratory. The filter testing performed was setup for a vertical downward flow regime. Different orientations in the field need to be considered with caution, especially into the sides of conduits.

Dividing the event tree into branches leading to breach for each of the erosion categories can be considered, particularly if the EE-CE portion is high. In addition, if the likely breach mechanism cannot be judged with confidence during

Appendix D-6-H Continuation

the potential failure mode analysis, estimating the breach probability later could be difficult if the understanding of the mechanism for each erosion category is widely different.

Although Fell et al. (2008) suggest that each of the erosion categories be carried through the event tree, Reclamation and USACE practice has been to come up with one estimate of the likelihood of an unfiltered exit (as discussed earlier), for which a filter evaluation is just one aspect. It is typical to assign the probability of an unfiltered exit based on not just the likelihood of the CE boundary, but also *considering* the likelihood of the EE boundary, as well as *considering* how far the material is from NE boundary. Reclamation and USACE also consider the variability of the gradations (from fine to coarse extremes), how thick the filtering unit is, how continuous it is likely to be and whether it extends to a free or open face.

Although fairly prescriptive, the assessment is similar to traditional filter evaluation but with more steps, and it can provide a better indication of the likelihood of the core material being filtered even when modern NE filter criteria are not met in all cases. An example is provided at the end of this chapter. If sufficient gradation exists, the filter evaluation involves the steps described below. If gradation data does not exist or is limited, gradations can be estimated based on the likely source of the materials and any processing, as described in Fell et al. (2008).

- Select representative gradations of the original (or re-graded) base soil (i.e., coarse, average, and fine base soil gradations) based on the fine and coarse base soil envelopes from all gradation tests. For example, if the representative base soil gradation corresponds to 80 percent of all gradation tests, then the fine base soil gradation is indicative of the coarser 10 percent of the base soils, and the fine base soil gradation is indicative of the finer 10 percent of the base soils.
- Assess the NE boundary based on the original (or re-graded) base soil for the coarse, average, and fine base soil gradations using table D-6-H-4. For highly dispersive soils (pinhole classification D1 or D2 or Emerson Class 1 or 2), it is recommended to use a lower D15F for the NE boundary, as shown in table D-6-H-5 based on modern particle retention criteria.
- Assess the CE boundary based on the actual (or re-graded) base soil for the coarse, average, and fine base soil gradations. For all soils, this is estimated as $D15F > 9(D95B)$ (Foster and Fell 1999, 2001).
- Plot the erosion boundaries on the original filter gradation curves (and the adjusted filter gradation curves for segregation or washout) on the D15 line.

Appendix D-6-H Continuation

Table D-6-H-4.—Criteria for NE Boundary for Non-Dispersive Soils (adapted from FEMA 2011)

Base Soil Category	Fines Content (percent)	Criteria for NE Boundary
1	FC > 85	$D_{15}F \leq 9(D_{85}B)$
2	$40 < FC \leq 85$	$D_{15}F \leq 0.7 \text{ mm}$
3	$15 < FC \leq 40$	$D_{15}F \leq (4(D_{85}B) - 0.7) \left(\frac{40 - FC}{25} \right) + 0.7$ If $4(D_{85}B) < 0.7 \text{ mm}$, use $D_{15}F \leq 0.7 \text{ mm}$.
4	FC ≤ 15	$D_{15}F \leq 4(D_{85}B)$

Notes: The fines content is the percentage finer by weight than 0.075 mm after the base soil is adjusted to a maximum particle size of 4.75 mm.

Table D-6-H-5.—Criteria for NE Boundary for Dispersive Soils (adapted from FEMA 2011)

Base Soil Category	Fines Content (percent)	Criteria for NE Boundary
1	FC > 85	$D_{15}F \leq 6.5(D_{85}B)$
2	$35 < FC \leq 85$	$D_{15}F \leq 0.5 \text{ mm}$
3	$15 < FC \leq 35$	$D_{15}F \leq (4(D_{85}B) - 0.5) \left(\frac{40 - FC}{25} \right) + 0.5$ If $4(D_{85}B) < 0.5 \text{ mm}$, use $D_{15}F \leq 0.5 \text{ mm}$
4	FC ≤ 15	$D_{15}F \leq 4(D_{85}B)$

Notes: The fines content is the percentage finer by weight than 0.075 mm after the base soil is adjusted to a maximum particle size of 4.75 mm.

Table D-6-H-6.—Criteria for EE Boundary (adapted from Foster and Fell 1999, 2001)

Base soil	Criteria for EE Boundary
$D_{95}B \leq 0.3 \text{ mm}$	$D_{15}F > 9(D_{95}B)$
$0.3 < D_{95}B \leq 2 \text{ mm}$	$D_{15}F > 9(D_{90}B)$
$D_{95}B > 2 \text{ mm}$ and FC ≤ 15 percent	$D_{15}F > 9(D_{85}B)$
$D_{95}B > 2 \text{ mm}$ and 15 percent < FC ≤ 35 percent	$D_{15}F > 2.5 \left((4(D_{85}B) - 0.7) \left(\frac{35 - FC}{20} \right) + 0.7 \right)$
$D_{95}B > 2 \text{ mm}$ and FC > 35 percent	$D_{15}F > (D_{15}F \text{ value for erosion loss of } 0.25\text{g/cm}^2 \text{ in the CEF test, as shown on figure D-6-H-2, can be estimated as } D_{15}F \approx 0.34(1.07)^{fm} \text{ by curve-fit})$

Notes: Criteria are directly applicable to soils with $D_{95}B$ up to 4.75 mm. For soils with coarser particles, determine $D_{85}B$ and $D_{95}B$ using gradation curves adjusted to give a maximum size of 4.75 mm.

Appendix D-6-H Continuation

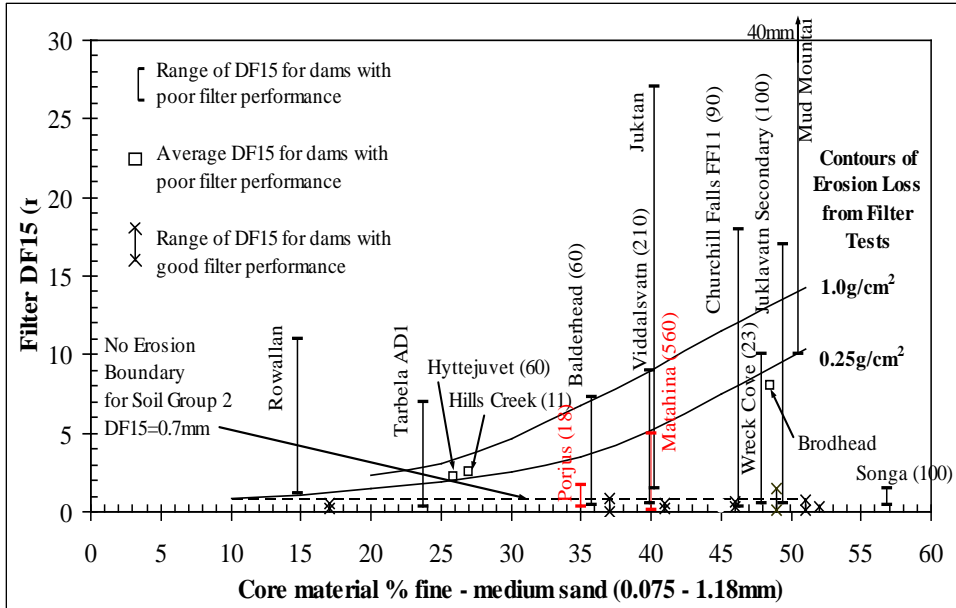

Figure D-6-H-2.—Criteria for EE boundary (adapted from Fell et al. 2008).

- Estimate the proportion of the original filter gradation (and filter gradation after segregation or washout) within each of the erosion categories for the coarse, average, and fine base soil gradations. The suggested approach is to estimate the proportions for the continuing, excessive, and some erosion categories first and then calculate the proportion for the NE category by subtracting the sum of the other proportions from one.

Coarse base soil gradation:

$$P_{NE, \text{ coarse}} = 1 - (P_{CE, \text{ coarse}} + P_{EE, \text{ coarse}} + P_{SE, \text{ coarse}})$$

Average base soil gradation:

$$P_{NE, \text{ average}} = 1 - (P_{CE, \text{ average}} + P_{EE, \text{ average}} + P_{SE, \text{ average}})$$

Fine base soil gradation:

$$P_{NE, \text{ fine}} = 1 - (P_{CE, \text{ fine}} + P_{EE, \text{ fine}} + P_{SE, \text{ fine}})$$

- Make an initial estimate of the probabilities of NE, some erosion, EE, and CE by calculating the sum-product of the percentage of base soil gradations and the estimated percentage of NE, some erosion, EE, and CE for the coarse, average, and fine base soil gradations. The calculations are as follows, where N corresponds to the representative base soil gradation (i.e., as a percentage of all gradation tests) and $n = (100 - N)/2$ corresponds to the percentage finer or coarser of the base soil:

Appendix D-6-H Continuation

$$P_{NE} = (n/100)(P_{NE, \text{coarse}}) + (N/100)(P_{NE, \text{average}}) + (n/100)(P_{NE, \text{fine}})$$

$$P_{SE} = (n/100)(P_{SE, \text{coarse}}) + (N/100)(P_{SE, \text{average}}) + (n/100)(P_{SE, \text{fine}})$$

$$P_{EE} = (n/100)(P_{EE, \text{coarse}}) + (N/100)(P_{EE, \text{average}}) + (n/100)(P_{EE, \text{fine}})$$

$$P_{CE} = (n/100)(P_{CE, \text{coarse}}) + (N/100)(P_{CE, \text{average}}) + (n/100)(P_{CE, \text{fine}})$$

- If the filter gradation is finer than the CE boundary, Fell et al. (2008) suggest using table D-6-H-7 to estimate the probabilities of CE (based on how much finer the gradations are compared to the CE boundary) to allow for the possibility of the gradations being coarser than indicated by the available information. *The probabilities should not be used directly in a risk assessment, but rather used to help develop a list likely of more likely and less likely factors during an elicitation of probability estimates.*

Table D-6-H-7.—Probability of CE when the Actual Filter Gradation Is Finer than the CE Boundary (adapted from Foster and Fell et al. 2008)

D_{15F}	P_{CE}
$< 0.1(D_{15F_{CE}})$	0.0001
$< 0.2(D_{15F_{CE}})$	0.001
$< 0.5(D_{15F_{CE}})$	0.01 – 0.05

- Assess if the filter materials are susceptible to cracking. The fines content of the representative boundary filter gradations on figure D-6-H-3 is between about 2 and 6 percent. Based on table D-6-H-1, the likelihood of the filter material holding a crack would be small, especially for non-plastic fines.
- Assess if the filter materials are susceptible to segregation. Based on table D-6-H-3, the boundary filter gradations on figure D-6-H-3 indicate the limits to prevent segregation are not met by a large margin. The minimum D_{10F} of about 0.25 mm correspond to a maximum D_{90F} to prevent segregation of 20 mm. However, the maximum D_{90F} is actually about 120 mm. Using the average filter gradation, the minimum D_{10F} is about 1 mm, and the maximum D_{90F} is about 95 mm. The maximum allowable D_{90F} is more like 30 mm, and again the criteria to limit segregation are not met.

Appendix D-6-H Continuation

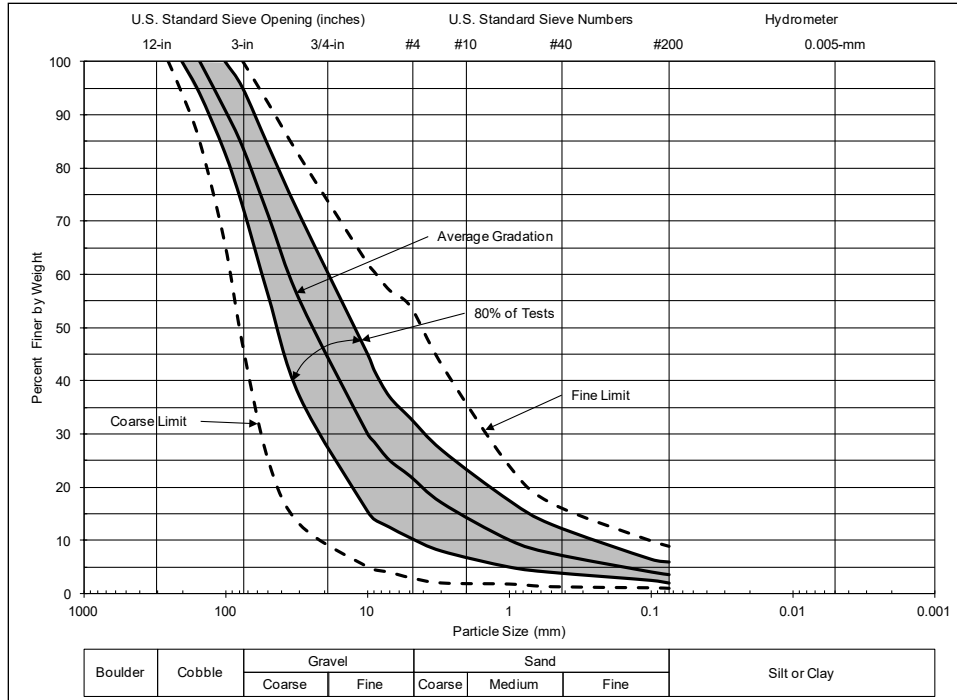

Figure D-6-H-3.—Example filter gradations.

- Assess if the filter materials are susceptible to internal instability. Based on Reclamation criteria, the ratio of say the D80F to the D10F particle sizes is much greater than 4, and the likelihood of internal instability appears to be small. However, the filter gradation curve was judged to have a flat tail of fines, which may be susceptible to internal instability.
- Assess the NE boundary based on the original (or re-graded) base soil for the coarse, average, and fine base soil gradations. The re-graded fines content of the base soil on figure D-6-H-4 is between 35 and 61 percent. Based on table D-6-H-4, the fines content corresponds to Base Soil Category 2 and a NE boundary of $D_{15F} < 0.7$ mm.
- Assess the EE boundary based on the original (or re-graded) base soil for the coarse, average, and fine base soil gradations. Based on table D-6-H-6, the base soil is best classified as a soil with $D_{95B} > 2$ mm and $FC > 35$ percent. This requires determining the EE boundary from figure D-6-H-2 using the percentage of material between 0.075 and 1.18 mm (defined as fine to medium sand). The results are summarized in table D-6-H-8.

Appendix D-6-H Continuation

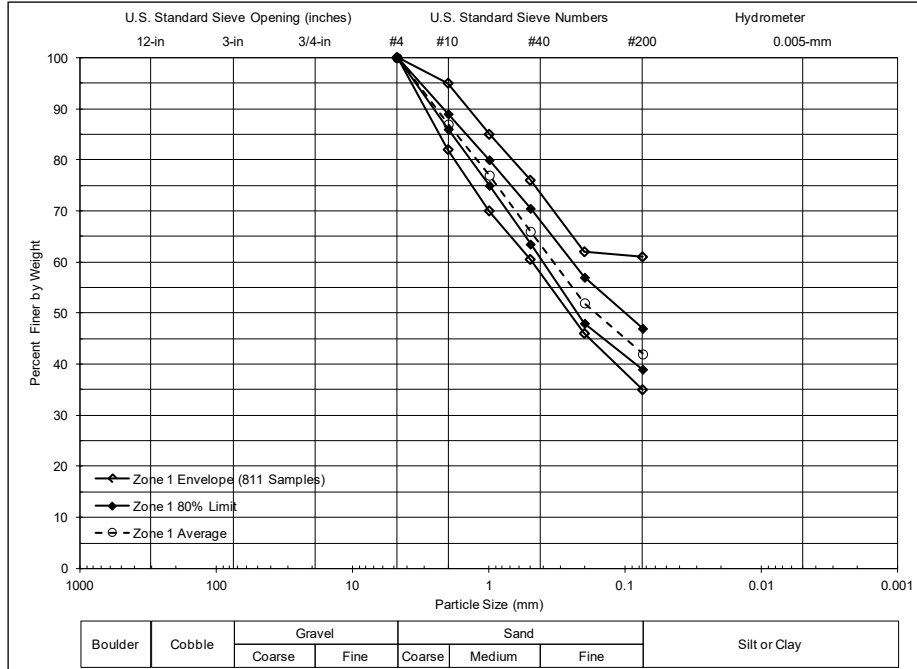

Figure D-6-H-4.—Example re-graded base soil.

- Assess the CE boundary based on the actual (or re-graded) base soil for the coarse, average, and fine base soil gradations as $D_{15}F < 9(D_{85}B)$. The results are summarized in table D-6-H-8.

Table D-6-H-8.—Erosion Boundaries for Example Base Soil

Core Gradation	Base Soil Characteristics			NE	E E	CE
	$D_{95}B$ (mm)	FC (%)	f-m Sand (%)	$D_{15}F$ (mm)	$D_{15}F$ (mm)	$D_{15}F$ (mm)
Coarse	4.0	35	39	0.7	5	36
Average	3.5	42	39	0.7	5	32
Fine	2.0	61	28	0.7	2	18

- Plot the erosion boundaries on the original filter gradation curves on the D_{15} line. The erosion boundaries are shown on figure D-6-H-5 for the original filter gradation.

Appendix D-6-H Continuation

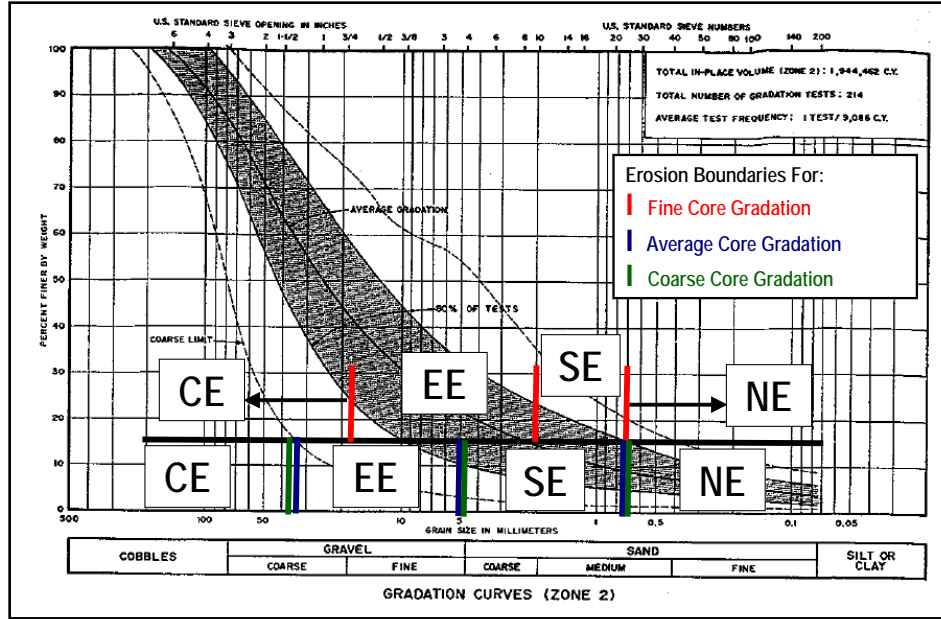

Figure D-6-H-5.—Erosion boundaries on D15F of original filter gradation.

- Estimate the gradation after segregation or washout. For filters that are susceptible to segregation or internal instability, Fell et al. (2008) recommended an approximate method for estimating the D₁₅F of filter materials after segregation or washout. The procedure assumes 50 percent of the finer soil fraction is segregated out or 50 percent of the unstable or erodible soil fraction is washed out. However, Fell (2016) indicated that it is more appropriate to assume 100 percent of the finer soil fraction is segregated out or 100 percent of the unstable or erodible soil fraction is washed out.

- 1) Select the point of maximum curvature on the original gradation curve. For broadly graded soils, the point of maximum curvature is the point of maximum inflection of the gradation curve, as shown on figure D-6-H-5. For gap-graded soils, this point corresponds to the particle size that is missing (i.e., the gap location), as shown in as shown on figure D-6-H-6.

Appendix D-6-H Continuation

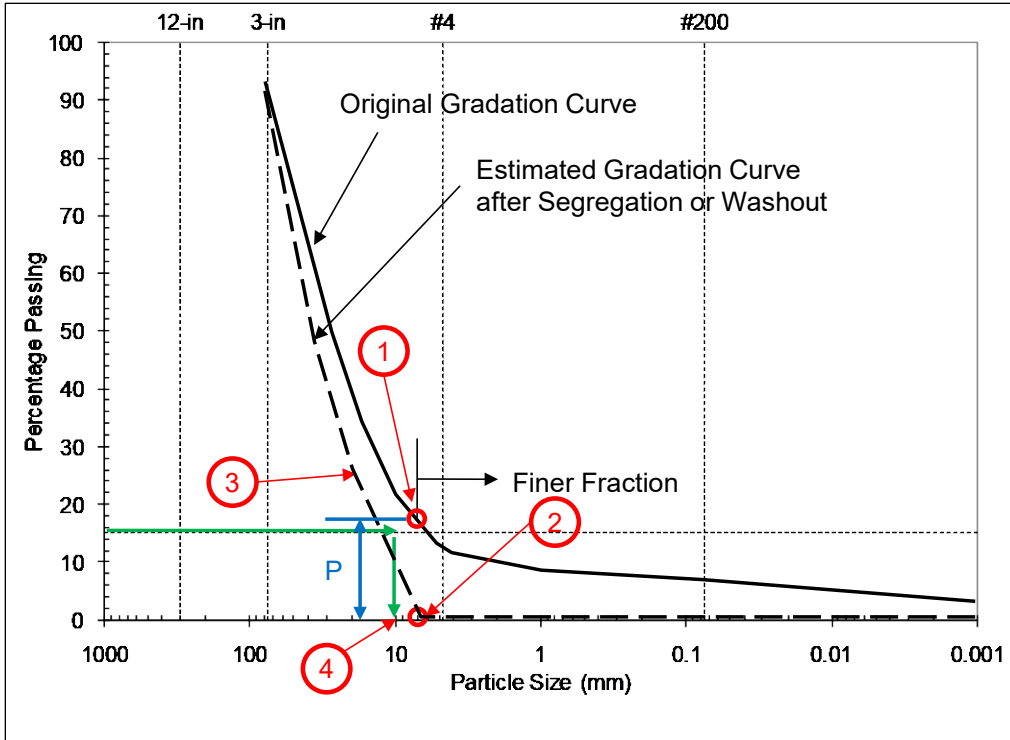

Figure D-6-H-1.—Procedure to obtain adjusted gradation after segregation or washout for broadly graded filter materials.

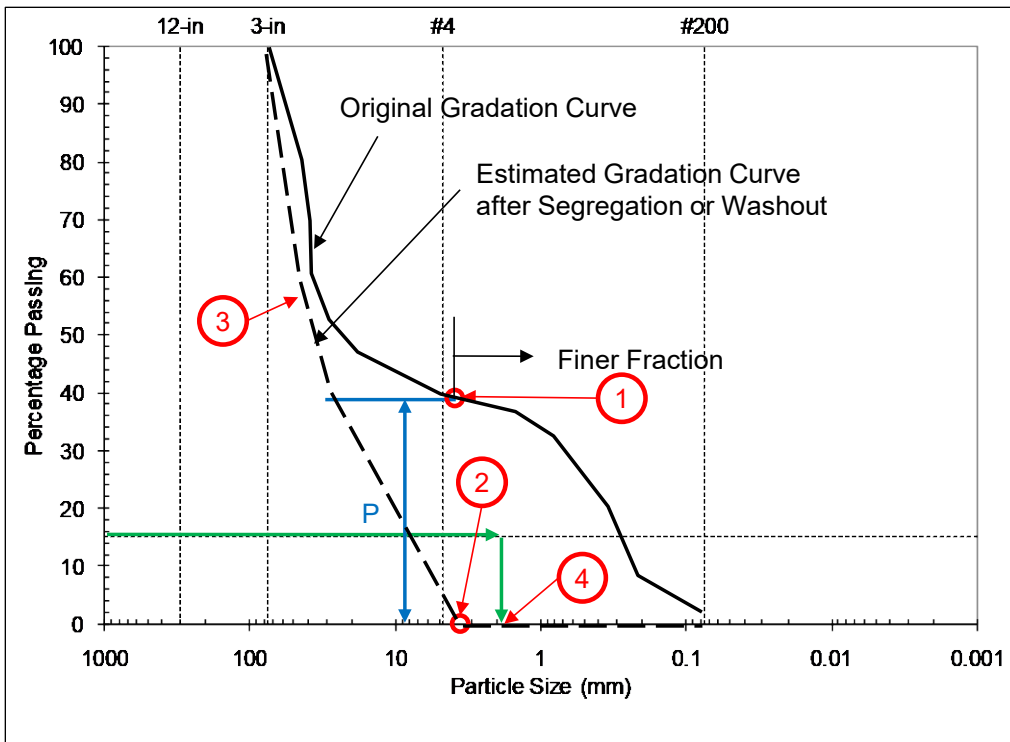

Figure D-6-H-2.—Procedure to obtain adjusted gradation after segregation or washout for gap-graded filter materials.

Appendix D-6-H Continuation

- 2) Adjust the point of maximum curvature downward by 100 percent (i.e., locate the point with 0 percent passing below the point of maximum curvature) because the procedure assumes 100 percent of the finer soil fraction is segregated out or 100 percent of the unstable or erodible soil fraction is washed out.
 - 3) Approximate the shape of the estimated gradation curve after segregation or washout by passing through the midpoint.
 - 4) Estimate the $D_{15}F$ after segregation or washout using the adjusted gradation curve.
- The adjusted gradation curve is shown on figure D-6-H-7. In this example, the point of maximum curvature was adjusted downward by one-half (i.e., locate the midpoint below the point of maximum curvature) based on the Fell et al. (2008) the procedure which assumes 50 percent of the finer soil fraction is segregated out or 50 percent of the unstable or erodible soil fraction is washed out. Therefore, this example is possibly un-conservative.

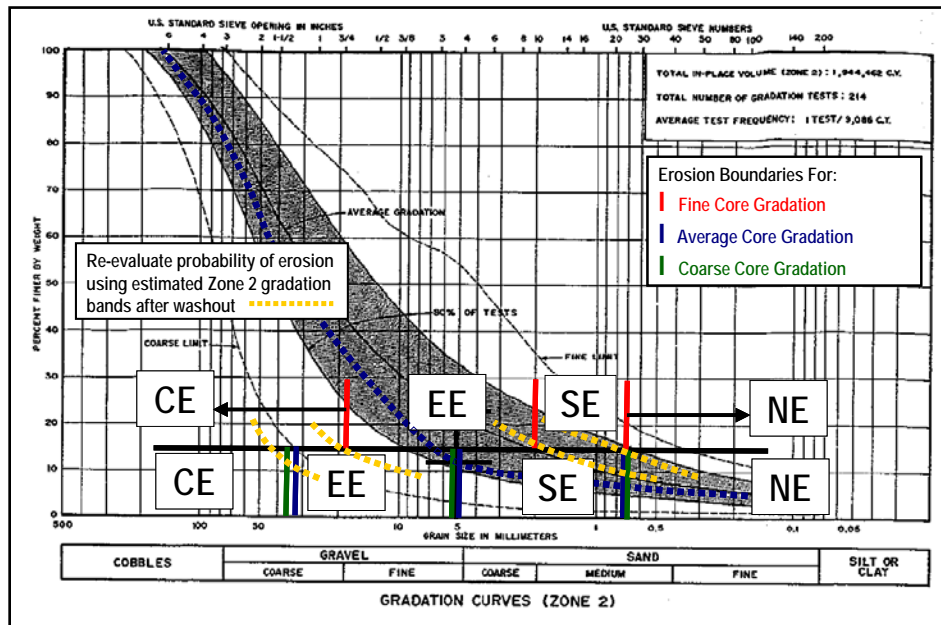

Figure D-6-H-7.—Erosion boundaries on $D_{15}F$ of adjusted gradation after segregation or washout. (Note: Example assumes 50 percent of finer fraction eroded.)

Appendix D-6-H Continuation

- Estimate the proportion of the original filter gradation (and filter gradation after segregation or washout) within each of the erosion categories for the coarse, average, and fine base soil gradations. By inspection, the approximate proportions of the gradation band within each erosion boundary are summarized in table D-6-H-9. The proportions for the NE category are calculated below.

Table D-6-H-9.—Proportions for Example Filter Material

Base Soil Gradation	NE	SE	EE	CE
Original Filter Gradation				
Coarser (10%)	0.10	0.60	0.30	0.00
Average (80%)	0.10	0.60	0.30	0.00
Finer (10%)	0.10	0.40	0.45	0.05
Adjusted Filter Gradation after Segregation or Washout				
Coarser (10%)	0.0	0.40	0.58	0.02
Average (80%)	0.0	0.40	0.56	0.04
Finer (10%)	0.0	0.10	0.80	0.10

For the original filter gradation:

$$\text{Coarse base soil gradation: } P_{\text{NE, coarse}} = 1 - (0 + 0.30 + 0.60) = 0.10$$

$$\text{Average base soil gradation: } P_{\text{NE, average}} = 1 - (0 + 0.30 + 0.60) = 0.10$$

$$\text{Fine base soil gradation: } P_{\text{NE, fine}} = 1 - (0.05 + 0.45 + 0.40) = 0.10$$

For the adjusted filter gradation after segregation or washout:

$$\text{Coarse base soil gradation: } P_{\text{NE, coarse}} = 1 - (0.02 + 0.58 + 0.40) = 0$$

$$\text{Average base soil gradation: } P_{\text{NE, average}} = 1 - (0.04 + 0.56 + 0.40) = 0$$

$$\text{Fine base soil gradation: } P_{\text{NE, fine}} = 1 - (0.10 + 0.80 + 0.10) = 0$$

- Make an initial estimate of the probabilities of NE, some erosion, EE, and CE by calculating the sum-product of the percentage of base soil gradations and the estimated percentage of NE, some erosion, EE, and CE for the coarse, average, and fine base soil gradations. The calculations are

Appendix D-6-H Continuation

as follows, where N corresponds to the representative base soil gradation (i.e., as a percentage of all gradation tests) and $n = (100 - N)/2$ corresponds to the percentage finer or coarser of the base soil:

For the original filter gradation:

$$P_{NE} = (10/100)(0.10) + (80/100)(0.10) + (10/100)(0.10) = 0.1$$

$$P_{SE} = (10/100)(0.60) + (80/100)(0.60) + (10/100)(0.40) = 0.58$$

$$P_{EE} = (10/100)(0.30) + (80/100)(0.30) + (10/100)(0.45) = 0.315$$

$$P_{CE} = (10/100)(0.00) + (80/100)(0.00) + (10/100)(0.05) = 0.005$$

For the adjusted filter gradation after segregation or washout:

$$P_{NE} = (10/100)(0.00) + (80/100)(0.00) + (10/100)(0.00) = 0$$

$$P_{SE} = (10/100)(0.40) + (80/100)(0.40) + (10/100)(0.10) = 0.37$$

$$P_{EE} = (10/100)(0.58) + (80/100)(0.56) + (10/100)(0.80) = 0.586$$

$$P_{CE} = (10/100)(0.02) + (80/100)(0.04) + (10/100)(0.10) = 0.044$$

The probability of continuation without considering other factors (e.g., filter thickness, continuity of coarse zones, presence of a free face, etc.) could be estimated on the low side as the probability of CE or 0.005 for the original filter gradation and 0.044 for the adjusted filter gradation after segregation or washout. If it were judged that there was a 10 percent chance of the segregated or washed out filter being in contact with the core, the minimum probability of continuation could be estimated as $0.1(0.044) + 0.9(0.005) \approx 0.01$. The maximum probability of continuation is based on examining the excessive and some erosion boundaries on figures D-6-H-6 and D-6-H-7. For example, if it were judged that there was about a 50 percent chance that soil within the EE category would not eventually plug off but practically no chance that soil within some erosion category would not plug off, then the probability of continuation for the original filter gradation could be estimated as $0.005 + 0.5(0.315) \approx 0.16$. Similarly, the probability of continuation for the adjusted filter gradation could be estimated as $0.044 + 0.5(0.586) \approx 0.34$. The weighted maximum probability of continuation is $0.1(0.34) + 0.9(0.16) \approx 0.2$. Therefore, probability of continuation is ranges from about 0.01 to 0.2.

APPENDIX D-6-I

Rate of Enlargement of a Pipe

While the resistance to initiation of concentrated leak erosion is characterized by the critical shear stress, the rate of pipe enlargement in the progression phase under a significantly long loading event is characterized by the erodibility coefficient (rate of change of erosion rate). There are several methods for estimating the erosion properties of soils for concentrated leak erosion. The Hole Erosion Test (HET), Jet Erosion Test (JET), and Erosion Function Apparatus are the most widely used tests. Further details on methods to estimate the erodibility parameters are discussed in “Chapter D-1, Erosion of Rock and Soil.”

Figure D-6-I-1 illustrates the importance of soil erodibility (characterized by the HET index) on the time for erosion to progress, based on the following assumptions: unrestricted potential for erosion (i.e., no flow limitation, continuing erosion condition); initial pipe diameter of 25 mm (1 inch); zero critical shear stress (which is conservative, particularly for $I_{HET} > 3.5$); shape of pipe remains circular; pipe can sustain a roof while it enlarges; and reservoir level remains constant. The time to erode to 2 m in diameter is about 20 percent greater.

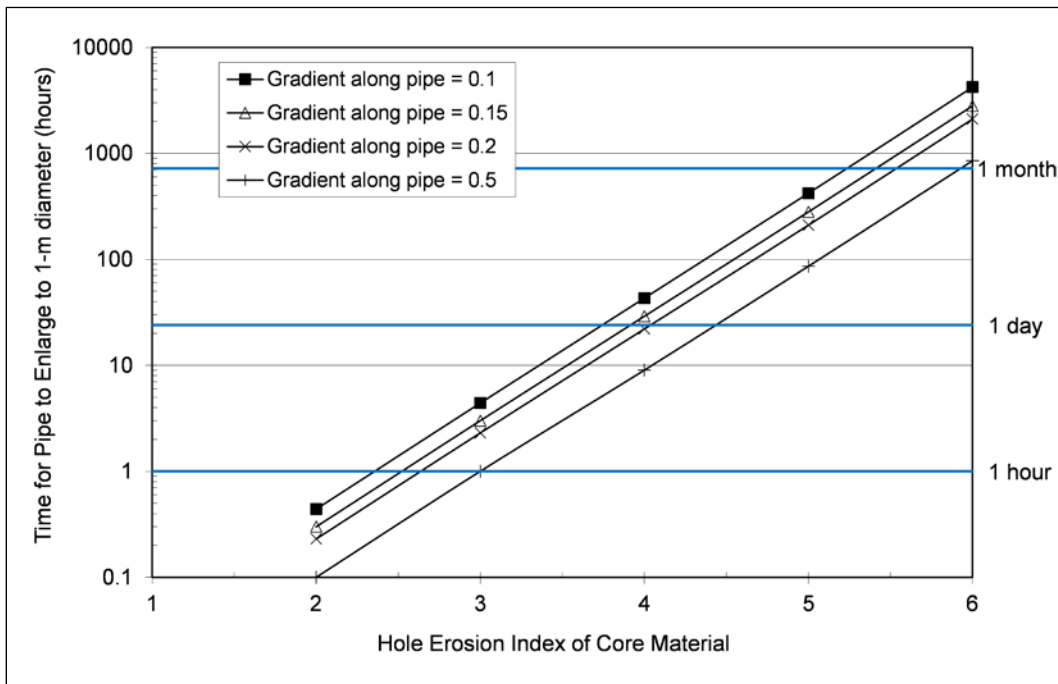

Figure D-6-I-1.—Approximate time for a pipe to enlarge from 25 mm to 1 m in diameter (Fell et al. 2008).

The rate of enlargement of a pipe in the progression phase can be estimated using methods described in Wan and Fell (2002) for a circular pipe. The rate of erosion per unit surface area at time t is given by:

Appendix D-6-I Rate of Enlargement of a Pipe

$$\dot{\varepsilon}_t = \frac{1}{\psi_t} \frac{dV_t}{dt} = k_d(\tau - \tau_c) \text{ for volume erosion} \quad \text{Equation D-6-I-1}$$

$$\dot{m}_t = \frac{1}{\psi_t} \frac{dM_t}{dt} = C_e(\tau - \tau_c) \text{ for mass erosion} \quad \text{Equation D-6-I-2}$$

where $\Psi_t = P_{w,t} L$ = surface area of the pipe at time t ; dV_t/dt = rate of soil volume removal due to erosion at time t ; dM_t/dt = rate of soil mass removal due to erosion at time t ; τ = hydraulic shear stress for the reservoir level under consideration; τ_c = critical shear stress for initiation of erosion; and k_d = erodibility coefficient; and C_e = coefficient of soil erosion.

Using the above equations, the erosion loss (per unit length) can be rewritten as:

$$dV_t = \dot{\varepsilon}_t \psi_t dt = k_d(\tau - \tau_c) P_w dt = k_d(\tau - \tau_c) (\pi \phi_t) dt \quad \text{Equation D-6-I-3}$$

for volume erosion

$$dM_t = \dot{m}_t \psi_t dt = C_e(\tau - \tau_c) P_w dt = C_e(\tau - \tau_c) (\pi \phi_t) dt \quad \text{Equation D-6-I-4}$$

for mass erosion

The change in pipe diameter at time t is given by:

$$d\phi_t = 2 \frac{dV_t}{\pi \phi_t} \text{ for volume erosion} \quad \text{Equation D-6-I-5}$$

$$d\phi_t = 2 \frac{dM_t}{\rho_d \pi \phi_t} \text{ for mass erosion} \quad \text{Equation D-6-I-6}$$

These equations can be readily setup in a spreadsheet to estimate the pipe diameter for user-specified time increments or steps based on estimates of hydraulic shear stress and erodibility parameters previously described and the following assumptions:

- Linear head loss from upstream to downstream
- Steady uniform flow along the pipe
- Zero pressure head at the downstream end
- Shape of the pipe remains circular
- Enlarging pipe can sustain a roof
- Uniform frictional resistance along the surface of the pipe or crack
- Driving force = frictional resistance
- Reservoir remains constant with time

Appendix D-6-I Rate of Enlargement of a Pipe

An example of portrayal of analytical results is shown on figure D-6-I-2. In this example, an initial pipe diameter was assumed, and the critical shear stress, erodibility coefficient, and range of pipe diameter at failure (D_f) were estimated by a risk team during an elicitation. Based on the estimated pipe diameter as a function of time, this figure can be used to help develop a list or more likely and less likely factors for the potential time available for intervention or full breach development as a function of reservoir level.

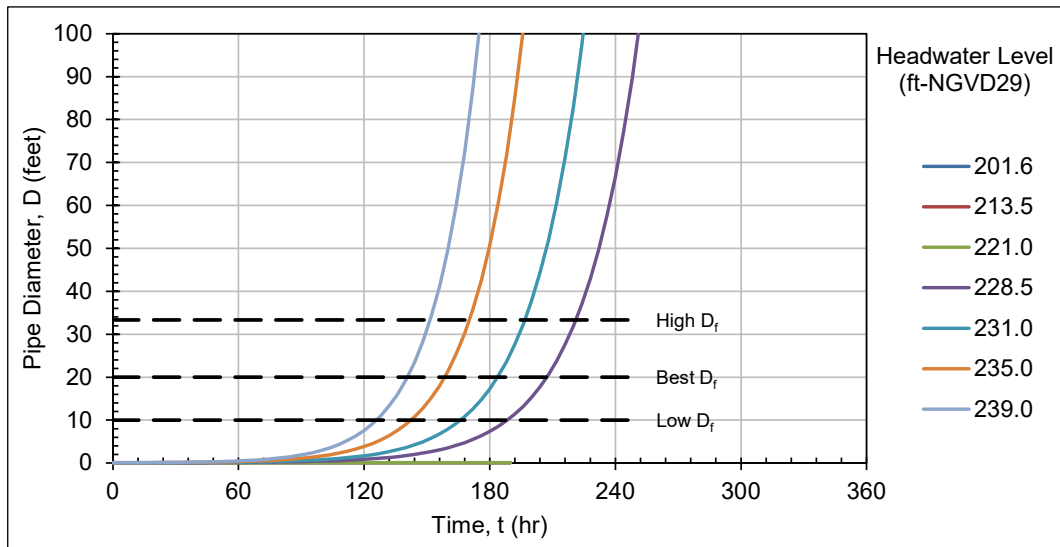

Figure D-6-I-2.—Example portrayal of analytical results for rate of enlargement of a pipe.

APPENDIX D-6-J

Tables of More and Less Likely Factors for Different
Categories of Internal Erosion

Table D-6-J-1.—Factors Influencing the Likelihood of Initiation of Internal Erosion Through an Embankment Dam

FACTORS INFLUENCING THE LIKELIHOOD OF INITIATION OF INTERNAL EROSION THROUGH AN EMBANKMENT DAM				DATE: JULY 2012
Factor	Influence on Likelihood / Relative to Reclamation Historical Base Rates (see notes)			Comments
	Less Likely	Neutral	More Likely	
Seepage Presence of seepage Seepage fluctuations	No seepage (low probability for a concentrated leak) Long-term steady rate of seepage unrelated to reservoir level	Insignificant seepage; or seepage possible but unseen Seepage fluctuates with reservoir, but at a predictable rate	Seepage significant Seepage is increasing over time at the same reservoir level; or seepage is episodic or surging	The presence or absence of seepage may not be known with certainty. Episodic seepage could be an indicator that an internal erosion pathway is repeatedly opening and closing. Evidence of material transport in seepage flow would indicate near certainty that erosion is occurring.
Soil Erodibility (adapted from Sherard, 1953)	Well-graded material with clay binder, (10<PI<15), well or poorly compacted Much less likely if plastic clay, PI > 15, well or poorly compacted	Well-graded, low plasticity material, (6<PI<10), well or poorly compacted	Well-graded, cohesionless material, (PI<6), well or poorly compacted Uniform, fine cohesionless sand, (PI<6), well or poorly compacted	Sherard's guidance is intended to represent the relative erodibility of a range of soil types with different PI and different compaction efforts. Use this guidance in conjunction with base rate statistics such as 87% of Reclamation incidents were in soils with PI < 7. Dispersive soils are not included here; dispersive soils can be much more erodible and rates of initiation should be adjusted to reflect dispersion potential.
Cracks – located on the crest, or in test pits that expose the upper part of the impervious zone.	No cracking observed when large areas, or all, of the top of the core is exposed	No cracking observed on the crest or in limited test pits exposing the core.	Transverse cracks on the surface of the core and/or, extensive, open longitudinal cracking. Much more likely for transverse cracks that extend across the core, and extend below reservoir water level being considered	At Reclamation it has not been standard practice to excavate test pits at the crest of the dam to expose the impermeable zone. Therefore, the potential for cracking generally relies on observations of cracks at or near the crest, and on other factors (in this table) that could increase or decrease the potential for cracking.
Sinkholes or depressions	No observations of sinkholes or depressions, including on upstream slope areas that are normally submerged.	Minor depressions on the upstream or downstream slopes that developed slowly and do not change over time.	Observations of sinkholes or depressions on the crest, upstream slope, or downstream slope that appear suddenly or change with time.	Sinkholes and depressions are important observations but are not always associated with an internal erosion potential failure mode. Localized settlement of limited loose zones in the embankment could result in sinkholes or depressions. Wave action on riprap can also create localized depressions. If sinkholes or depressions are observed, look for nearby conduits, toe drains, coarse graded materials or other anomalies that could allow for material transport. Sinkholes and depressions

FACTORS INFLUENCING THE LIKELIHOOD OF INITIATION OF INTERNAL EROSION THROUGH AN EMBANKMENT DAM				DATE: JULY 2012
Factor	Influence on Likelihood / Relative to Reclamation Historical Base Rates (see notes)			Comments
	Less Likely	Neutral	More Likely	
				could result from seepage through internally unstable soils that allow material transport to occur.
Loose or soft zone within the impervious zone	Cone penetration tests, or continuous sampling, show no loose or softened zones	No investigations	Softened or loose zones detected by drilling and sampling of the impermeable zone	Use caution, follow appropriate guidelines and work with an experienced engineering geologist when drilling and sampling in an embankment dam.
Construction (also see general quality of construction below) Compaction equipment	Material compacted with appropriate equipment, with well-documented quality control test results	Material compacted with appropriate equipment	Material compacted by dozer or "equipment travel;" no specific compaction by rollers; Much more likely for materials placed and spread by horse with no formal compaction.	Poor compaction can result in a low density and high permeability zone through the embankment. Judgment is necessary when evaluating construction – material compacted in thin lifts with horse drawn and water conditioning may be well-compacted. Compaction and density ranges stated are for general guidance purposes.
Compaction density and moisture	Compacted to greater than 98% Standard Proctor dry density; 0 to +2% of optimum water content	Compacted to 95-98% Standard Proctor dry density; -2% to +2% of optimum water content	Poorly compacted; dry of optimum water content	
Impermeable zone width	Homogeneous earthfill dam; zoned earthfill with very wide impervious zone with relatively flat slopes. Ratio of reservoir head to width of core (both measured at a potential location of internal erosion) less than 1.	Zoned earthfill with wide impervious zone. Ratio of reservoir head to width of core (both measured at a potential location of internal erosion) between 1 and 2.	Zoned earth or rockfill dam with a narrow core. Ratio of reservoir head to width of core (both measured at a potential location of internal erosion) greater than 2.	Greater widths of impermeable zones make it less likely for a continuous defect (e.g. crack or high permeability zone) to form. Many Reclamation dams were built with a wide impervious zone.
Differential settlement of foundation (also see differential settlement due to closure section)	Rock foundation or soil foundation with consistent low compressibility.	Shallow soil foundation, or soil foundation with gradual variation in thickness and compressibility.	Soil foundation adjacent to rock foundations; variable depth and compressibility of foundation soils. Firm compacted soils adjacent to loose, compressible foundation soils. Much more likely if collapsible soils (loess; weakly cemented soils) are present. Also much more likely if localized, deep compressible soils are within less compressible soils.	Differential settlement can occur anywhere two adjacent materials with different compressibility characteristics are located. (e.g. rock and soil; firm backfill of diversion channel or conduit through looser foundation, etc.). Differential settlements can lead to cracking in low stress zones.
Foundation profile under the impermeable zone (also see slope of abutments)	Uniform foundation profile, gradual abutment slopes; absence of terraces, steps or benches	Profile has some, but not extreme undulations and variability. Might include a wide bench in the bottom half of the dam; or narrow bench in the upper half of the dam; gradual excavation slopes adjacent to benches	Profile has abrupt changes; especially if abrupt changes are in the upper half to third of the embankment; wide terraces or benches adjacent to steep excavations. Much more likely if terraces or benches are continuous across the core/	Adverse shaped foundation profiles can cause low stress zones, differential settlement and cracking. Haul roads and grouting platforms can result in horizontal, upstream to downstream benches.

FACTORS INFLUENCING THE LIKELIHOOD OF INITIATION OF INTERNAL EROSION THROUGH AN EMBANKMENT DAM				DATE: JULY 2012
Factor	Influence on Likelihood / Relative to Reclamation Historical Base Rates (see notes)			Comments
	Less Likely	Neutral	More Likely	
			impermeable zone.	
Settlement (during construction and post construction, as percentage of embankment height)	Approx. 1% or less during construction. Approx. 0.25% or less post-construction.	Approx. 1-3% during construction. Approx. 0.25% - 1% post construction.	Approx. 3-5% during construction. Approx. 1-2% post construction. Much more likely for settlements greater than 5% during construction. Much more likely for post construction settlement greater than 2%.	Other considerations for settlement include the duration over which the settlement has occurred, and location of settlement (crest, upstream slope, downstream slope). Differential settlement between different points across the dam should be considered, particularly if differential settlement locations align with foundation profile changes or changes in foundation material compressibility. This guidance is from Fell, Wan and Foster (2004) and is based on work by Hunter and Fell (2003).
Foundation preparation of surface irregularities (foundation of the impermeable zone) and construction of first lifts on foundation	Uniform rock surface, or rock surface treated with dental concrete or shotcrete; foundation shaping to remove irregularities; special compaction of the first several lifts of impermeable material on rock; impermeable materials at the contact have at least moderate plasticity, maximum particle size < 3 inches; gradation not subject to segregation. Alternately, a uniform well-compacted, dense, low permeability soil foundation.	Irregular rock surface with minimal treatment and shaping; or untreated undulating rock surface without significant irregularities; little or no special compaction of the first lifts of impermeable materials on rock; impermeable materials at the contact have low plasticity. Alternately, a compacted soil foundation.	Highly irregular, untreated, rock surface with no shaping or treatment; no special compaction of the first lifts of impermeable materials on rock; impermeable materials at the contact are non-plastic; Broadly graded impermeable materials that could have segregated or may be internally unstable. Alternately, an irregular or benched soil foundation with light or no compaction. Much more likely if a rock foundation surface was blocky and included loose rock.	Inadequate foundation preparation could result in a high permeability zone, low stress zone or other transverse defect causing a concentrated leak along the embankment/ foundation contact. This factor may be more relevant to PFMs related to the foundation, but foundation irregularities could cause embankment defects deep in the dam.
Slope of abutments (also see foundation profile)	Gentle abutment slope, generally 30 degrees (from horizontal) or less	Moderate abutment slope, approximately 30-45 degrees (from horizontal)	Steep abutment slope, generally greater than 45 degrees (from horizontal); Much more likely if abutment slopes are greater than 60 degrees.	In general, steeper abutment slopes would tend to promote greater differential settlements over shorter distances, which could lead to cracking or low stress zones. The influence of abutment slope should be evaluated along with the foundation profile and the influence of benches, terraces or abrupt changes in geometry. For very steep abutments and a narrow valley, “arching” of the soils across the valley can lead to horizontal transverse

FACTORS INFLUENCING THE LIKELIHOOD OF INITIATION OF INTERNAL EROSION THROUGH AN EMBANKMENT DAM				DATE: JULY 2012
Factor	Influence on Likelihood / Relative to Reclamation Historical Base Rates (see notes)			Comments
	Less Likely	Neutral	More Likely	
				cracking and low stress zones.
Differential settlement due to closure section construction	No closure section through the embankment (off stream dam or river diverted using outlet works, tunnel, or other means).	Well-built closure section.	Closure section that may have remained open for several construction seasons; construction on compressible soils leading to differential settlements between existing fill and closure fill; change in borrow source or change in material characteristics; little or no quality control with the possibility that disturbed materials were not removed. Rapid construction of closure section.	Unique stress and settlement behavior may be associated with closure sections, which may have different material types and rapid construction. A well-built closure section would be characterized by: good design and construction details that provide a good bond between existing fill and closure fill; flat side slopes; built on firm materials; no substantial change in borrow material characteristics; careful quality control with good base soil preparation including excavation and replacement of disturbed materials.
Seasonal shut-down	No seasonal shut down and no fill placement during freezing weather. Weather and fill placement schedule well documented.	Seasonal shut down or potential for placement during freezing weather, with good documentation of fill being removed or treated, moisture conditioned, re-compacted and tested before commencing with additional fill placement.	One or more seasonal shut downs for an extended period; frozen / disturbed materials not removed, surface not treated before commencing fill placement; or lack of documentation of removal / treatment. Much more likely if there is documentation of frozen fill that was not removed or treated.	Seasonal shut-down or fill placement in freezing weather can lead to a high permeability zone through the dam.
Embankment zoning and overall geometry	Wide homogeneous earthfill dam or zoned earthfill dam with zones that have similar deformation characteristics; Earthfill dam with filters and drains with similar deformation characteristics.	Wide homogeneous earthfill dam with limited zones with varying deformation characteristics; Zoned earthfill dam with filters and drains with varying deformation characteristics. Central core rockfill dam with compacted core and rockfill, with core stiffness greater than or equal to that of the rockfill.	Central core earth and rockfill with uncompacted rockfill or rockfill placed in large lifts; Central core earth and rockfill with narrow core of lower modulus than filters and rockfill. Consider relative width of the core compared to the rockfill zones and the potential for “hang up” or arching of the core between stiffer filter and rockfill zones.	In general, zoning of an embankment dam is beneficial for seepage control; however, this factor considers the potential for variable deformation behavior due to different material types and compaction amounts that might lead to differential settlement, cracking or low stress zones.
General quality of construction and quality control (also see construction as related to compaction above)	Good clean-up and preparation of any wet, dry, or frozen surfaces during construction. Good supervision and quality control. Complete, well-documented records that confirm the high quality construction.	Good clean-up and preparation of any wet, dry, or frozen surfaces during construction. Good supervision and quality control. Some detailed records and documentation.	Poor clean-up after wet, dry, or frozen periods during construction. Intermittent supervision and quality control. Much more likely if there was no or poor supervision and quality control.	Embankment lift surfaces left to dry and crack could result in concentrated leaks. Wet or frozen zones left in the dam could result in high permeability zones or differential settlements. In general, Reclamation dams have been constructed

FACTORS INFLUENCING THE LIKELIHOOD OF INITIATION OF INTERNAL EROSION THROUGH AN EMBANKMENT DAM				DATE: JULY 2012
Factor	Influence on Likelihood / Relative to Reclamation Historical Base Rates (see notes)			Comments
	Less Likely	Neutral	More Likely	
				with good supervision, quality control and documentation; however, a detailed examination of quality control records may be needed to reveal additional details beyond the generalizations (averages) often published in construction reports.
Lift thickness (of impermeable material)	Same as for “neutral” but with complete, well-documented records that confirm the lift thickness was controlled.	Lift thickness 8-10 inches loose (6-8 inches after compaction). Few detailed records and little documentation.	Lift thickness at the limit of compaction equipment (e.g. ~ 15 inches loose). No documentation. Much more likely if lift thickness beyond the limit of compaction equipment (e.g. > 18 inches); or no control on lift thickness.	Loose lifts or uncompacted zones can result in a high permeability zone and concentrated leak through the dam.
Impermeable material characteristics	Same as for “neutral” but with complete, well-documented records that confirm material characteristics.	Low variability of material particle size, not subject to segregation, insitu borrow material at or near optimum water content; good moisture conditioning in the borrow area and/or on the fill.	Some variability in material particle size, some potential for segregation; insitu borrow material dry of optimum water content; moderate moisture conditioning on the fill. Much more likely with large variability of material particle size, broadly graded soils subject to segregation or internal instability; borrow materials significantly dry of optimum water content in borrow area, with poor moisture conditioning	
Desiccation cracking	Low plasticity core, temperate climate; pavement and/or other zones over core of sufficient thickness to prevent desiccation	Low to medium plasticity core, seasonally dry or temperate climate; pavement and/or other zones over core of sufficient thickness to prevent desiccation	Medium to high plasticity core, seasonally dry and hot climate, no pavement or other material over core; or insufficient thickness to prevent desiccation.	Applies to core, or impermeable zone for homogeneous dams.
Instrumentation details in the core / impervious zone	No instrumentation in the impervious zone	Some instrumentation (cables or piezometers) passing through the core; but designed and constructed with appropriate details.	Instrumentation (cables or piezometers) passing through the core; but lack of appropriate details. Upstream to downstream penetrations through the core are more of a concern than vertical penetrations.	Appropriate design and construction details would include placement and good compaction of plastic impervious materials around instruments, cables or other penetrations.
Reservoir operation	Steady operational levels	Operational levels cycle annually, reaching the normal maximum operational level during most years. Reservoir level increases at a relatively slow, steady rate.	Reservoir has never reached the normal maximum operational level; or reservoir operates well below the normal maximum level for years and reaches the normal maximum level infrequently. Reservoir level increases rapidly, or reservoir level is “flashy.”	Soils in embankment dams strain in response to changes in stresses associated with reservoir level changes. Slower rates of change allow embankments to deform slowly in response to change, decreasing the chance of a crack or low stress zone.

FACTORS INFLUENCING THE LIKELIHOOD OF INITIATION OF INTERNAL EROSION THROUGH AN EMBANKMENT DAM				DATE: JULY 2012
Factor	Influence on Likelihood / Relative to Reclamation Historical Base Rates (see notes)			Comments
	Less Likely	Neutral	More Likely	
Extensive vegetation, root balls, rodent holes	No trees or vegetation, no root balls, no evidence of rodents.	Limited vegetation that is controlled before root systems become extensive. Limited rodent activity primarily in downstream shell zones away from the impermeable zone.	Large trees in the groins, on the crest or on the downstream slope; certain vegetation with extensive root systems; stumps with decaying root systems. Rodent holes, particularly those of large rodents that excavate dens in embankments when the reservoir is low.	Vegetation, root systems and rodent holes can increase the gradient within a dam by short-cutting seepage paths. The extent of damage caused by rodents may not be realized until the reservoir rises. The significance of rodent burrows depends on the size of the embankment.
Age of dam / length of service	In service greater than 20 years, reaching the normal maximum water surface elevation almost every year.	In service 5- 20 years, reaching the normal maximum water surface elevation most years.	Newer dam, in service less than 5 years; Alternatively, older dam that has not been tested to up to the normal maximum water surface elevation.	Reclamation and world-wide statistics indicate incidents are more likely to occur in the first few years of reservoir operation. However, those statistics reflect many historical incidents with older dams, and one could argue that modern designed and constructed dams are less likely to have first filling incidents. In addition, evidence suggests that internal erosion incidents can develop at any age.

Notes on use of Table:

1. Table is intended to provide guidance in addition to historical base rates of initiation of internal erosion. The neutral factors listed in the table would correspond to average base rates. Neutral factors do not imply a 50% probability. In general for a given Reclamation dam, there would be justification to select a probability of initiation of internal erosion higher than historical base rates if that dam was characterized by multiple “more likely” factors listed above; and conversely, there would be justification to select a probability of initiation of internal erosion lower than historical base rates if that dam was characterized by multiple “less likely” factors. Whether the estimated probability of initiation of internal erosion is higher, lower or near the historical base rate, the justification for the estimated probability must be documented. This table provides some guidance for that justification.
2. Some factors listed on the table apply to all internal erosion mechanisms (backward erosion piping, internal migration, scour, suffusion/suffosion) while some factors might only apply to one mechanism.
3. Some factors listed on the table are more critical to initiation of internal erosion than others. In general, more influential factors are listed towards the top of the table and less influential factors are listed towards the bottom.
4. For some factors, the “More likely” column also includes factors that would make the probability of initiation “much more likely.”
5. Expert guidance is critical for interpreting observations at a dam and making judgments that relate performance of a specific dam to historical base rates of internal erosion.

References:

Draft Risk Analysis Methodology Appendix E (2000), Estimating Risk of Internal Erosion and Material Transport Failure Modes for Embankment Dams, version 2.4, Bureau of Reclamation, Technical Service Center, Denver, CO. August 18, 2000. (This document was never finalized; it was superseded in 2008 by Dam Safety Risk Analysis Best Practices Training Manual, Chapter 24.)

Fell, R., C.F. Wan, and M. Foster (2004), "Progress Report on Methods for Estimating the Probability of Failure of Embankment Dams by Internal Erosion and Piping," University of New South Wales, Sydney, Australia. UNICIV Report 428. 2004.

Hunter, G. and Fell, R. (2003). The Deformation Behaviour of Embankment Dams. UNICIV Report No. R-416. ISBN: 0077-880X, School of Civil and Environmental Engineering, The University of New South Wales.

Sherard, J.L. (1953), "Influence of Soil Properties and Construction Methods on the Performance of Homogeneous Earth Dams," Technical Memorandum 645, Bureau of Reclamation, Denver, Colorado.

Table D-6-J-2.—Factors Influencing the Likelihood of Continuation of Internal Erosion

FACTORS INFLUENCING THE LIKELIHOOD OF CONTINUATION OF INTERNAL EROSION				DATE: JULY 2012
Factor	Influence on Likelihood (see notes)			Comments
	Less Likely	Neutral	More Likely	
Filter Presence / Embankment zoning – Is there a zone of material that would serve as a filter? (see also “Materials downstream of filter” below).	Zoned embankment dam. Dam with a well-designed and constructed filter. Much less likely if the design includes a two-stage filter and drain.	There is a granular zone downstream of the impervious zone that was not specifically designed to filter (e.g. transition zone, coarse granular zone or dirty shell/rockfill); more geotechnical information is needed to evaluate this condition.	Dam is homogeneous, or there is no zone downstream of the impermeable zone that would serve as a filter (e.g. riprap slope protection or a clean rockfill zone).	This is a broad, general consideration. There is no need for a detailed evaluation of the probability of an unfiltered exit for dams that have no materials that would serve as a filter; i.e. P ~ 1.0.
Filter Gradation - Gradation of the zone immediately downstream of the impervious zone if there is no modern designed filter; or the filter gradation if a filter exists.	Average D ₁₅ F satisfies no erosion criteria. Much less likely if the coarsest D ₁₅ F satisfies no erosion criteria.	Most of the D ₁₅ F satisfy no erosion criteria for most of the impervious zone gradations, and the coarsest D ₁₅ F is less than the excessive erosion boundary. Some embankment designs in the 1950s and 1960s included wide, broadly-graded filters (sometimes called “transition zones”). These gradations may or may not satisfy no erosion criteria and they are likely subject to segregation during construction; a detailed evaluation is warranted considering the potential for extensive areas of cobbles with little or no finer material. This would be of more concern at the top of a dam where this zone might be narrower than lower in the dam.	Likely if the average D ₁₅ F does not satisfy no erosion criteria, but the coarsest D ₁₅ F is less than the excessive erosion boundary. More likely if the average and coarsest D ₁₅ F are greater than the excessive erosion boundary. Much more likely if the average D ₁₅ F exceeds the continuing erosion boundary.	Relative guidance is provided here. Judgment is needed to estimate the probability that erosion would continue for materials that do not satisfy no erosion criteria. Generally, if D ₁₅ F does not satisfy no erosion criteria, but does not exceed the continuing erosion boundary, a detailed evaluation of gradations, and the estimated representativeness of those gradations, is warranted.
Cracking of filter, or zone immediately downstream of the impervious zone, due to fines content and compaction.	Well compacted material with < 5% non-plastic fines. Much less likely for poorly-compacted material with < 5% non-plastic fines.	Poorly-compacted material with 5-15% non-plastic fines. Poorly-compacted material with 5-7% plastic fines.	Well-compacted material with 5-15% non-plastic fines, or poorly-compacted material with >15% non plastic fines. Well-compacted material with 5-7% plastic fines, or poorly-compacted material with 7-15% plastic fines. Much more likely for well-compacted material with > 7% plastic fines or poorly-compacted material with >15% plastic fines.	The descriptors in this row provide guidance on the likelihood of <u>cracking</u> , not solely continuation (adapted from Fell, Wan, Foster 2004). Increased fines content in materials serving as a filter increases the likelihood that a crack will hold. Consideration should be given to fines content and plasticity, particularly for materials not specifically designed as filters but constructed adjacent to impermeable materials. The sand castle test is a simple test that can be used to evaluate the ability of a filter material to collapse or self-heal.

FACTORS INFLUENCING THE LIKELIHOOD OF CONTINUATION OF INTERNAL EROSION				DATE: JULY 2012
Factor	Influence on Likelihood (see notes)			Comments
	Less Likely	Neutral	More Likely	
Materials downstream of filter	Two stage filter and drain designed such that the drain material satisfies particle retention criteria for the filter. Sufficient overburden pressure on the filter to prevent uplift if a concentrated leak and high pressure develops.	Two stage filter and drain not provided, but materials downstream of filter have gradations that prevent erosion of filter materials. Sufficient overburden pressure on the filter to prevent uplift if a concentrated leak and high pressure develops.	Two stage filter and drain not provided, and materials downstream of filter could allow erosion of filter materials. Insufficient overburden pressure on the filter to prevent uplift if a concentrated leak develops and there is no, or minimal, head loss.	Modern designs typically include a two-stage filter and drain system; however, many Reclamation dams that have not been modified do not have a two-stage system. If a coarse material, such as a rockfill shell, is placed downstream adjacent to a filter, the filter could be eroded into the shell. If the downstream zone could sustain a crack, the filter could be eroded through the crack.
Filter Location	Filter material in direct contact with impermeable zone.	Filter located in a downstream zone, but not directly adjacent to the impermeable zone materials. The zone between the impervious zone and the filter is granular but was not designed as a filter; or it is unlikely to serve as a repository for eroded materials.	Filter located in a downstream zone, but not directly adjacent to the impermeable zone materials. The zone between the impervious zone and the filter could serve as a repository for eroded materials.	Having a filter located downstream, but not adjacent to, the impermeable zone is not an ideal design; however for some modification designs (particularly seismic modifications) it might be necessary. Consideration should be given to the possibility that impervious materials would erode and be deposited in a zone between the impermeable zone and the downstream filter.
Filter Width (horizontal width downstream of impervious zone)	Filter is > 8 ft wide and segregation during construction was minimized. Much less likely if filter is > 12 ft.	Filter is between 4 and 8 ft wide.	Filter is < 3 to 5 ft wide. Segregation considerations are significant for narrow filters. See below. Much more likely if filter is < 1.5 ft wide.	In general wider filters have a greater likelihood of being constructed as a continuous zone. Wider filters also have a smaller likelihood of a continuous coarse zone extending from upstream to downstream. These factors are for static considerations only, not seismic.
Filter segregation during construction	Gradation meets Reclamation segregation design criteria; uniformly graded material. Good quality construction methods to prevent segregation.	Gradation does not meet Reclamation segregation design criteria. However, construction methods employed that limited segregation; use of spreader boxes; hand working materials; good construction inspection. Construction procedures may have resulted in limited areas of coarser materials, but no continuous (upstream to downstream) zones of coarse, segregated materials.	Gradation does not meet Reclamation segregation design criteria. Materials stockpiled; materials dumped from a truck on fill; other construction methods not employed that could limit segregation; limited or no construction inspection. Construction procedures used that could have resulted in a continuous (upstream to downstream) zone of coarse, segregated materials.	Reclamation segregation criteria are provided in the Protective Filter Design Standard (Reclamation 2011a). Segregation could also result in suffusion (see below)
Suffusion – potential for internal instability and erosion of filter materials	Uniformly graded materials.	Well-graded materials or other materials that are not uniformly graded, but not	Broadly-graded materials or gap-graded materials that are potentially internally	Broadly-graded materials serving as filters may be subject to suffusion – resulting in a

FACTORS INFLUENCING THE LIKELIHOOD OF CONTINUATION OF INTERNAL EROSION				DATE: JULY 2012
Factor	Influence on Likelihood (see notes)			Comments
	Less Likely	Neutral	More Likely	
		internal unstable.	unstable. Materials with sufficient coarse fraction such that effective stresses are carried by the coarse fraction, enabling the finer fraction to erode out.	loss of filter compatibility because the filter will no longer retain D15 and smaller particles.
Gradation testing - both the impervious zone to be filtered, and the materials adjacent to the impervious zone that would serve as a filter.	Many gradation test results available from pre-construction (borrow areas); construction (after compaction) and/or post-construction (as part of a filter evaluation).	Some gradation test results available from pre-construction (borrow areas); construction (after compaction) and/or post-construction (as part of a filter evaluation). Samples may not be completely representative of the materials constructed.	Very limited, or no gradation test results available. Little knowledge about the types of soils or the borrow areas used during construction.	Gradation test results provide confidence in the ability to evaluate the potential for an unfiltered exit. When there is little or no information available, significant uncertainty is introduced; however, that uncertainty does not automatically mean there is a high probability of an unfiltered exit; rather a large range should be considered until additional information can be obtained and evaluated further.
Toe drains – drains that could provide an unfiltered exit.				
Drain pipe condition	Thoroughly inspected drains with no problems (breaks, cracks, roots, material accumulation, etc.)	No inspections have been performed – significant uncertainty	Inspections indicate problems with drains (e.g. broken pipe, poor joints, evidence of material transport – much more likely if impermeable zone has been eroded).	Toe drains have presented problems at several Reclamation dams and can serve as an unfiltered exit point. Typical Reclamation designs for many years included open-joint clay tile pipe. In many cases inspections have revealed crushed or clogged pipe. Poor pipe condition does not automatically mean there is a high probability of an unfiltered exit. Evaluate filter and drain envelope and perforations for no erosion, some erosion, and continuing erosion criteria
Drain pipe design	Good design typically including filter sand and drain rock	Details on drain design not available	Poor design details; lack of proper filter and drain elements	
Drain pipe construction	Good construction details and records		Poor construction details	
Drain pipe outflow	Clear flow; no evidence of material transport		Evidence of material transport in flow.	
Characteristics of filter and drain envelope	Designed filter and drain envelope that meet no erosion criteria and are of sufficient thickness to prevent failure and minimize construction defects	Gradations of filter and drain envelope not available.	No drain envelope	

Notes on use of Table:

1. Table is intended to provide guidance on the probability of continuation of internal erosion, or the probability of an unfiltered exit. Unlike with the “initiation” tables, there are no historical average base rates to compare relative probabilities. The more likely and less likely factors can be considered qualitatively, and can be applied when there is very little information (e.g. gradations) available for a quantitative estimate. The

neutral factors listed in the table are factors that have a small influence on the likelihood, or factors that could equally increase or decrease the likelihood of continuation. Neutral factors do not automatically imply a 50% probability.

2. The probability of continuation, or continuing erosion, is estimated by relying heavily on the evaluation of base soil gradations, filter gradations, and calculated erosion boundaries, as described by Foster and Fell (1999, 2001).
3. Some factors listed on the table are more critical to continuation of internal erosion than others. In general, more influential factors are listed towards the top of the table and less influential factors are listed towards the bottom.
4. For some factors, the “More likely” column also includes factors that would make the probability “much more likely.”

References:

Draft Risk Analysis Methodology Appendix E (2000), Estimating Risk of Internal Erosion and Material Transport Failure Modes for Embankment Dams, version 2.4, Bureau of Reclamation, Technical Service Center, Denver, CO. August 18, 2000. (This document was never finalized; it was superseded in 2008 by Dam Safety Risk Analysis Best Practices Training Manual, Chapter 24.)

Fell, R., C.F. Wan, and M. Foster (2004), “Progress Report on Methods for Estimating the Probability of Failure of Embankment Dams by Internal Erosion and Piping,” University of New South Wales, Sydney, Australia. UNICIV Report 428. 2004.

Foster, M.A. and Fell, R. (1999), “Assessing Embankment Dam Filters Which Do Not Satisfy Design Criteria,” UNICIV Report No. R-376, School of Civil and Environmental Engineering, University of New South Wales. ISBN: 85841 343 4, ISSN 0077-880X.

Foster, M. and Fell, R. (2001). Assessing Embankment Dam Filters Which Do Not Satisfy Design Criteria. J. Geotechnical and Geoenvironmental Engineering, ASCE, Vol.127, No. 4, May 2001, 398-407.

Bureau of Reclamation (2011a). Design Standard 13 Embankment Dams, Draft Chapter 5, Protective Filters. October 2011.

Bureau of Reclamation (2011b), Dam Safety Risk Analysis Best Practices Training Manual.

Table D-6-J-3.—Factors Influencing the Likelihood of Progression of Internal Erosion

FACTORS INFLUENCING THE LIKELIHOOD OF PROGRESSION OF INTERNAL EROSION				DATE: JULY 2012
Factor	Influence on Likelihood (see notes)			Comments
	Less Likely	Neutral	More Likely	
Progression – Continuous stable roof and/or sidewalls				If the primary mechanism is “internal migration” without formation of a roof or pipe, then this node can be eliminated from the event tree.
Presence and continuity of hard layer, dense zone or stiff zone	No hard, dense or stiff zones above erodible materials.	The possibility exists that a dense or stiff zone could provide a roof over a developing pipe for a portion of the distance between the reservoir and the exit point, but unlikely that the roof would be supported over the entire distance.	Likely that a dense or stiff zone exists that could provide a roof over a developing pipe between the reservoir and the exit point. Much more likely (approaching certainty) if there is confidence that a hard layer exists from upstream to downstream above erodible materials. Concrete structures such as spillways, conduits, or walls can provide roof support. Hardpan, caliche, basalt, etc. in the foundation soils also are much more likely to serve as a roof.	The primary consideration is whether a hard, dense or stiff zone exists in the embankment or foundation continuously from upstream to downstream above the erodible materials being considered. Dense clayey embankment or foundation materials could support a roof over loose, erodible materials. Guidance for probability estimating is provided in the Best Practices manual (Reclamation 2011).
Impervious zone - soil type, fines content, plasticity and moisture	Granular soils with 5-15% non-plastic fines, either moist or saturated. Much less likely for non-plastic, primarily granular soils with <5% fines, either moist or saturated. Coarse cohesionless shells for backward erosion piping in the foundation immediately beneath the embankment.	Granular soils with 5-10% cohesive fines. Moist soils in this category would be more likely to hold a roof than saturated soils.	Granular soils with 10-15% cohesive fines. Moist soils in this category would be more likely to hold a roof than saturated soils. More likely for granular materials with >15% non-plastic fines. Moist soils in this category would be more likely to hold a roof than saturated soils. Much more likely (approaching certainty) for materials with >15% plastic fines. Also much more likely for primarily fine grained, non-plastic materials with >50% fines.	Factors influencing the ability of a soil to hold a roof include type, fines content, plasticity and moisture. Within each column, density of materials would influence the ability to form a roof, with denser (well-compacted) materials being more likely and looser (poorly compacted) materials being less likely. Detailed guidance for probability estimating is provided in the Best Practices manual (Reclamation 2011).
Other Considerations				The presence of a hard layer and material properties are the primary factors, but soil variability, length of path through the core, potential for stress arching, swelling in expansive soils (most applicable to flood loading), and other factors may need to be considered.

FACTORS INFLUENCING THE LIKELIHOOD OF PROGRESSION OF INTERNAL EROSION				DATE: JULY 2012
Factor	Influence on Likelihood (see notes)			Comments
	Less Likely	Neutral	More Likely	
Progression – Constriction or upstream zone fails to limit flows				In order for a zone to limit flows, the zone must remain stable while flow through the dam is occurring. Openings in the upstream zone must be sufficiently small to prevent further erosion of downstream zones.
Presence of upstream zones or materials that could restrict flow	<p>Low to medium permeability granular zone (e.g. well-graded, compacted rockfill zone with cohesionless finer materials) upstream of the impervious zone.</p> <p>Central concrete core wall or any vertical complete cutoff such as a cement-bentonite wall, sheet pile wall, secant wall, etc.</p> <p>Much less likely for a well-designed and constructed concrete-faced rockfill dam or a dam with a sound soil-cement upstream face.</p> <p>Typically much less likely for seepage paths into small bedrock apertures, small cracks in conduits, or limited opening sizes and capacity of drains. However, this might not be a significant factor for failure modes in which internal migration and breach by sinkhole development is likely.</p>	Moderate permeability granular zone (e.g. rockfill) upstream of the impervious zone.	<p>Homogeneous dam with no upstream zone that could limit flows. Riprap would provide no flow limitation.</p> <p>Upstream zone judged to be capable of supporting a roof.</p>	<p>Few Reclamation dams have a concrete core wall or an upstream concrete face; therefore, in most cases there is no specific zone that would limit flows. However, in some cases, it may be reasonable to give some credit to the ability of the upstream portion of a homogeneous dam to limit flows, particularly if the upstream portion of the homogeneous dam is judged to be unlikely to support a roof. Also must consider whether a feature that could cause a flaw in the core also could cause a flaw in the upstream zone.</p> <p>The potential for upstream materials falling into and literally filling the crack in highly erodible cores (in the upstream portion) may not provide much benefit. Erodible soils would very likely erode around the edges of the filled erosion path.</p>

FACTORS INFLUENCING THE LIKELIHOOD OF PROGRESSION OF INTERNAL EROSION				DATE: JULY 2012
Factor	Influence on Likelihood (see notes)			Comments
	Less Likely	Neutral	More Likely	
Progression – No self-healing by upstream zone				Are upstream zone materials capable of being transported to a downstream zone or constriction where a filter could form sufficient to prevent further erosion of the core? Crack fillers are discussed in Sherard and Dunnigan (1985).
Material upstream of impervious zone	Coarse, clean, cohesionless upstream materials with wide range of particles sizes. Large volume of upstream materials. Much less likely if dam has an upstream zone specifically designed to provide self-healing.	Materials upstream of impervious zone consist of granular materials with some fines. Materials with limited non-plastic fines would be more likely to be transported than materials with plastic fines. A wider zone would be more likely to provide sufficient quantity of materials to self-heal than a narrow zone. A well-graded granular material is more likely to self-heal compared to a uniform sand.	Materials upstream of impervious zone consist of granular materials with significant amount of plastic or non-plastic fines. Relatively thin upstream zone of riprap and riprap bedding. Much more likely (approaching certainty) for a homogeneous dam, or if there are no materials upstream of the impervious zone capable of filling a crack or erosion pathway.	The zoning configuration of some dams might allow for an upstream zone to fill in a crack or erosion pathway through the impervious zone. Many homogeneous Reclamation dams have a relatively thin upstream slope protection zone of riprap and riprap bedding that could provide very limited self-healing.
Gradation of zone downstream of impervious zone	Filter or transition zone that would be a filter (or a “stop”) for the upstream materials washing through the crack or erosion pathway through the impervious zone.	Embankment materials downstream of the impervious zone that might or might not be a filter (stop) for the upstream materials washing through the crack or erosion pathway.	Homogeneous dam with no materials downstream of the impervious zone that would be a filter (stop) for the upstream materials washing through the crack or erosion pathway. Coarse (rockfill) zone downstream of the impervious zone.	If no downstreams zone is present, then no benefit should be given to this node (i.e., p=1.0). Upstream zone benefit is related to filter compatibility between core and the downstream zone or constriction. There is less benefit when sizes in the upstream zone are similar to those already in core. In other words, a wide range of sand sizes might be available from the upstream zone that were not available in the core, and could be carried to the downstream zone where self-healing could occur. (Note that “self-healing” of the core materials on the downstream zone was already considered under the “Continuation Node” if excessive and continuing erosion criteria were evaluated.)
Size and nature of	Crack of limited width or small hydraulic	Multiple erosion pathways may be	Large erosion pathway such as a rounded	The size and nature of the erosion pathway

FACTORS INFLUENCING THE LIKELIHOOD OF PROGRESSION OF INTERNAL EROSION				DATE: JULY 2012
Factor	Influence on Likelihood (see notes)			Comments
	Less Likely	Neutral	More Likely	
the crack or erosion pathway	fracture.	possible; it is difficult to envision at what point in the erosion process the crack or erosion pathway would be plugged by the upstream zone. Timing and internal erosion mechanism are important considerations that need to be carefully evaluated. For example, upstream zones may not be effective for backwards erosion piping, but could be effective for scour along a crack.	pipe.	would be related to how the potential failure mode is envisioned. There is a balance between the upstream zone particle size, the size of the crack and flow required to transport a certain particle size. It is usually more likely to self-heal earlier in the process when sand size particles could be carried to a downstream zone by relatively low flows. Gravel and larger sizes need high flows to be transported, so by the time flows are large enough, significant enlargement of the erosion pathway may have already occurred.

Notes on use of Table:

1. Table is intended to provide guidance on the probability of progression of internal erosion. Unlike the “initiation” tables, there are no historical average base rates to compare relative probabilities. The more likely and less likely factors can be considered qualitatively, and can be considered along with verbal descriptors for a quantitative estimate. The neutral factors listed in the table are factors that have a small influence on the likelihood, or factors that could equally increase or decrease the likelihood of progression. Neutral factors do not automatically imply a 50% probability.
2. For some factors, the “More likely” column also includes factors that would make the probability “much more likely.”

References:

Draft Risk Analysis Methodology Appendix E (2000), Estimating Risk of Internal Erosion and Material Transport Failure Modes for Embankment Dams, version 2.4, Bureau of Reclamation, Technical Service Center, Denver, CO. August 18, 2000. (This document was never finalized; it was superseded in 2008 by Dam Safety Risk Analysis Best Practices Training Manual, Chapter 24.)

Fell, R., C.F. Wan, and M. Foster (2004), “Progress Report on Methods for Estimating the Probability of Failure of Embankment Dams by Internal Erosion and Piping,” University of New South Wales, Sydney, Australia. UNICIV Report 428. 2004.

Bureau of Reclamation (2011), Dam Safety Risk Analysis Best Practices Training Manual.

Sherard, J.L. and Dunnigan, L.P. (1985). Filters and Leakage Control, in Embankment Dams, in Seepage and Leakage From Dams and Impoundments. ASCE Geotechnical Engineering Division Conference, 1-30.

Table D-6-J-4.—Factors Influencing the Likelihood that Intervention Fails for Internal Erosion

FACTORS INFLUENCING THE LIKELIHOOD THAT INTERVENTION FAILS FOR INTERNAL EROSION				DATE: JULY 2012
Factor	Influence on Likelihood (see notes)			Comments
	Less Likely	Neutral	More Likely	
Detection Factors				
Signs of internal erosion are detectable and recognizable	Adequate monitoring system with a plan specifically developed to address internal erosion potential failure modes. Well-trained dam operations, maintenance and monitoring staff.	Ability to detect may vary seasonally, depending on weather (snow, rain), vegetation (thick grass, tall vegetative cover), etc.	Little or no monitoring system. No trained staff. Evidence of eroded materials masked by rockfill zone, or eroded away by seepage flows.	
Evaluation of instrumentation data	Piezometric and seepage weir flow data is regularly evaluated; long-term trends are reviewed; look for changes in behavior.		Piezometric and seepage weir flow data is not collected or evaluated.	
Opportunity to observe signs of internal erosion (“eyes on the dam”)	On site dam tender; frequent site visits; specific observations focused on areas where internal erosion could develop (d/s of conduits, walls; groin areas; d/s toe area, etc.).	Ability to observe, may vary seasonally, depending on season (summer versus winter recreationists) weather, and other factors (park ranger patrols, etc.).	Infrequent site visits.	
Rate of erosion pathway development	Erosion expected to occur slowly; slow enlargement of the erosion pathway. Erosion resistant materials (e.g. dense, plastic materials).		Erosion expected to occur rapidly; rapid enlargement of the erosion pathway. Erosive materials (e.g. loose silt, sandy silt, granular materials with non-plastic fines).	Slower developing erosion pathways are more likely to be detected.
Physical Intervention Actions				
Reservoir drawdown	Significant and effective emergency release capability (compared to the expected rate of development of the failure mode). Decisions made to release in a timely manner, despite potential adverse downstream consequences.		Small emergency release capability (compared to the expected rate of development of the failure mode). Potential failure mode is related to the outlet works and its use could worsen the situation. Decisions not made to release in a timely manner.	The question is: Can physical intervention actions be taken in time to stop or slow the failure process to the point where dam breach does not occur? In some cases, the entrance point for a potential failure mode may be associated with a particular defect (e.g. a high permeability lift) and drawdown to just below the elevation of that defect could be very effective intervention.
Material erodibility	Erosion pathway is through rock; erodible soils not involved.	Erosion pathway is mostly through erosion resistant materials, therefore allowing greater time for intervention efforts	Erosion pathway is mostly through erosive materials, therefore allowing little time for intervention efforts	

FACTORS INFLUENCING THE LIKELIHOOD THAT INTERVENTION FAILS FOR INTERNAL EROSION				DATE: JULY 2012
Factor	Influence on Likelihood (see notes)			Comments
	Less Likely	Neutral	More Likely	
Erosion mechanism	Small sinkholes on the crest or downstream face caused by suffusion or internal migration	Large sinkholes on the crest caused by suffusion or internal migration. Scour of erosion pathway through crack.	Large sinkhole on upstream face; backwards eroding pipe	
Accessibility of downstream exit point	Easily accessible for construction equipment.	Difficult access for construction equipment; additional time and effort would be needed to construct access.	Difficult access for construction equipment; soft/wet areas, poor roads; crest width; bridge restrictions across dam crest.	
Adequate filter and drain material available	Large stockpile of filter compatible materials available on site. Large embankment freeboard could allow for “cannibalization” of the upper parts of the embankment.		No nearby source of appropriate filter and drain materials. Little or no freeboard to allow for “cannibalization” of the upper parts of the embankment.	The farther along the internal erosion process that a failure mode has progressed, the larger the volume of materials that are needed to effectively intervene.
Ability to quickly mobilize equipment and materials	Equipment and materials readily available on site.	Equipment and materials readily available from the local water district, a nearby contractor, or a nearby sand and gravel supplier and can be mobilized with minimal delay. Pre-established agreements with local contractors to supply equipment and materials.	Equipment and materials not readily available; difficulties envisioned with procurement and mobilization to the site.	
Accessibility of upstream sinkhole or entrance point	Sinkhole or entrance point easily reached from the dam crest.	Location of potential sinkhole or entrance point could be anywhere on the upstream face of the dam.	Sinkhole or entrance point not likely to be within reach of the dam crest.	
Availability of large material to plug the sinkhole or entrance point	Appropriately sized materials are stockpiled on site.	Materials are available nearby and can be mobilized with minimal delay.	No nearby source of appropriate materials.	
Capability of intentional breach	A benign breach area exists (smaller low hazard dike location, reservoir rim area, etc.) that would allow a lesser uncontrolled release of the reservoir. Flooding would not impact a populated area.		No benign breach area exists.	

Notes on use of Table:

1. Table is intended to provide guidance on the probability that intervention fails for internal erosion. Intervention includes both detection and physical intervention components. Although the probability that intervention fails is evaluated just before breach, it is understood that intervention efforts could occur at any time.
2. Unlike the “initiation” tables, there are no historical average base rates to compare relative probabilities. The more likely and less likely factors can be considered qualitatively, and can be considered along with verbal descriptors for a quantitative estimate. The neutral factors listed in the table are factors that have a small influence on the likelihood, or factors that could equally increase or decrease the likelihood of unsuccessful intervention. Neutral factors do not automatically imply a 50% probability.

References:

Draft Risk Analysis Methodology Appendix E (2000), Estimating Risk of Internal Erosion and Material Transport Failure Modes for Embankment Dams, version 2.4, Bureau of Reclamation, Technical Service Center, Denver, CO. August 18, 2000. (This document was never finalized; it was superseded in 2008 by Dam Safety Risk Analysis Best Practices Training Manual, Chapter 24.)

Fell, R., C.F. Wan, and M. Foster (2004), "Progress Report on Methods for Estimating the Probability of Failure of Embankment Dams by Internal Erosion and Piping," University of New South Wales, Sydney, Australia. UNICIV Report 428. 2004.

Bureau of Reclamation (2011), Dam Safety Risk Analysis Best Practices Training Manual.

Table D-6-J-5.—Factors Influencing the Likelihood of Dam Breach

FACTORS INFLUENCING THE LIKELIHOOD OF DAM BREACH				DATE: JULY 2012
Factor	Influence on Likelihood (see notes)			Comments
	Less Likely	Neutral	More Likely	
Gross enlargement of pipe or erosion pathway				
Internal erosion mechanism	Internal migration or suffusion/suffosion.		Scour or backward erosion piping.	
Embankment Zoning			Much more likely for homogeneous embankment. Zoned embankment dam with compacted sand and gravel downstream shell that can hold a roof. Thin downstream zone of granular materials not capable of resisting significant flows.	If a large rockfill zone exists downstream that could resist significant amounts of flow, the more likely breach mechanism is sloughing.
Reservoir size and Freeboard	Very small reservoir that drains out before a full dam breach can develop. Very large freeboard (many tens of feet).		Large reservoir with sufficient volume to maintain high head, high gradients and plenty of flow during the internal erosion process. “Normal” or “average” amount of freeboard.	A large amount of freeboard could possibly prevent the dam from overtopping when the crest collapses, but must consider if crest collapse would only delay the breach.
Sloughing / Unraveling				
Internal erosion mechanism	Internal migration.	Suffusion or suffosion.	Scour or backward erosion piping.	
Embankment Zoning	A large, tightly knitted rockfill zone containing large rocks exists downstream that could resist significant amounts of flow.		Zoned embankment dams with compacted sand and gravel downstream. not able to resist significant flows. Homogeneous embankment consisting of soils that are not capable of sustaining a roof and that will not resist significant flows.	
Reservoir size and Freeboard	Very small reservoir that drains out before a full dam breach can develop. Large freeboard (tens of feet).		Large reservoir with sufficient volume to maintain high head, high gradients and plenty of flow during the internal erosion process. “Normal” or “average” amount of freeboard.	Large freeboard could possibly allow formation of a “berm” at the downstream slope from the slumped material that ultimately arrests breach development.
Sinkhole Development				
Internal erosion mechanism	Scour or backward erosion piping.		Internal migration or suffosion.	Sinkholes could possibly lead to other

FACTORS INFLUENCING THE LIKELIHOOD OF DAM BREACH				DATE: JULY 2012
Factor	Influence on Likelihood (see notes)			Comments
	Less Likely	Neutral	More Likely	
				internal erosion processes and/or breach mechanisms.
Likely location of sinkhole	Sinkhole on downstream or upstream slope and not likely to impact crest		On crest	Upstream sinkholes are generally considered to be more serious than downstream sinkholes and potentially indicate a serious condition. This table considers the likelihood that the sinkhole results in overtopping.
Freeboard	A large amount of freeboard exists (tens of feet).		Typical freeboard (~6-10 ft). Much more likely if there is little freeboard (< 6 ft).	
Crest width	Wide crest	Average crest	Narrow crest	
Flow limiter	A core wall or upstream concrete face remains in place			
Slope Instability				
Embankment Zoning	Large, free-draining rockfill or gravel downstream zone Drainage zone with high capacity that will prevent buildup of pore pressures in downstream zones		Sands, silty sands, and other materials in downstream zones susceptible to shear strength reduction with increased pore pressures	
Static slope stability	Analysis and evidence indicates significant margin of safety against instability.		Analysis or evidence indicates marginal stability; observations of sloughs or slides	
Freeboard	A large amount of freeboard exists		Typical freeboard Much more likely if there is little freeboard	
Crest width	Wide crest	Average crest	Narrow crest	
Downstream slope	Earthfill: 3:1 or flatter Rockfill: 1.75:1 or flatter	Earthfill: 2.5:1 Rockfill: 1.5:1	Earthfill: 2:1 or steeper Rockfill: 1.4:1 or steeper	

Notes on use of Table 5:

1. Table is intended to provide guidance on the probability of dam breach for internal erosion.
2. Unlike the “initiation” tables, there are no historical average base rates to compare relative probabilities. The more likely and less likely factors can be considered qualitatively, and can be considered along with verbal descriptors for a quantitative estimate. The neutral factors listed in the table are factors that have a small influence on the likelihood, or factors that could equally increase or decrease the likelihood of unsuccessful intervention. Neutral factors do not automatically imply a 50% probability.

References:

Draft Risk Analysis Methodology Appendix E (2000), Estimating Risk of Internal Erosion and Material Transport Failure Modes for Embankment Dams, version 2.4, Bureau of Reclamation, Technical Service Center, Denver, CO. August 18, 2000. (This document was never finalized; it was superseded in 2008 by Dam Safety Risk Analysis Best Practices Training Manual, Chapter 24.)

Fell, R., C.F. Wan, and M. Foster (2004), "Progress Report on Methods for Estimating the Probability of Failure of Embankment Dams by Internal Erosion and Piping," University of New South Wales, Sydney, Australia. UNICIV Report 428. 2004.

Bureau of Reclamation (2011), Dam Safety Risk Analysis Best Practices Training Manual.

Table D-6-J-6.—Factors Influencing the Likelihood of Initiation of Internal Erosion through the Foundation

FACTORS INFLUENCING THE LIKELIHOOD OF INITIATION OF INTERNAL EROSION THROUGH THE FOUNDATION	DATE: JULY 2012
<p>The factors below from the table for <u>Internal Erosion Through an Embankment Dam</u> also apply to this category of <u>Internal Erosion of through the Foundation</u>. Minor adjustments to the wording are required for some of the factors to be applicable solely to the foundation. Some considerations for adjustments are presented below, and judgment must be exercised as well.</p> <p>Seepage Soil Erodibility Sinkholes or depressions – Sinkholes or depressions observed on the embankment surface may indicate collapse of the embankment into an erosion pathway in the foundation. Differential settlement of foundation – Differential settlement in the foundation may crack the foundation soils as well as the overlying embankment. Desiccation cracking – Desiccation cracks in a soil foundation might not have been completely removed prior to placing the embankment materials. Reservoir operation – Erosion in the foundation might only occur during peak reservoir levels. Additionally, drought periods may allow for damage to the foundation by animals. Extensive vegetation, root balls, rodent holes Age of dam / length of service</p>	

FACTORS INFLUENCING THE LIKELIHOOD OF INITIATION OF INTERNAL EROSION THROUGH THE FOUNDATION				DATE: JULY 2012
Factor	Influence on Likelihood / Relative to Reclamation Historical Base Rates (see notes)			Comments
	Less Likely	Neutral	More Likely	
Foundation soil characteristics				Refer to erodibility of soils for general considerations
Backward Erosion Piping	Cohesive soils with PI>7 Pockets of cohesionless soils that are not continuous		Fine, cohesionless soils continuous from upstream to downstream	
Scour or Internal Migration	No open-work foundation soils	Some coarse-grained deposits exist, but of questionable continuity and not particularly high porosity	Continuous layers of high porosity or open-work gravels and/or cobbles	
Suffusion/suffosion	Soils not susceptible to internal instability		Glacial soils Soils with gradations susceptible to suffusion/suffosion	
Presence of karstic features	Much less likely – no karstic features present	Karstic features are at depth or were recognized and properly treated	Features such as solution channels, brecciated zones, ancient chimneys and similar were present beneath dam footprint, with marginal treatment measures	
Foundation grouting	Multiple row grout curtain in rock foundation;	Single row grout curtain in rock foundation; typical USBR grouting practices employed	No grouting of bedrock foundation that appears to have potential for seepage	Improperly designed and executed grouting programs can lead to windows for concentrated flow and high gradients.

FACTORS INFLUENCING THE LIKELIHOOD OF INITIATION OF INTERNAL EROSION THROUGH THE FOUNDATION				DATE: JULY 2012
Factor	Influence on Likelihood / Relative to Reclamation Historical Base Rates (see notes)			Comments
	Less Likely	Neutral	More Likely	
				Additional considerations include angle of grouting (versus joint orientation) and grout closure criteria.
Presence of bedrock discontinuities	Minimal rock jointing and fracturing reported Much less likely if bedrock reported to be massive	Some bedrock discontinuities reported, but no widespread areas of fracturing/jointing	Embankment footprint contains large areas of significantly jointed or fractured bedrock, or contains prominent continuous joints or fracture patterns	The continuity of any bedrock feature such as a fault, joint, or fracture system is an important factor as to whether a seepage path will develop
Nature of bedrock discontinuities	Bedrock joints and fractures reported or observed to be tight	Bedrock joints or fractures reported or observed to be relatively tight, infilled, or open only a few millimeters	Bedrock joints and fractures reported or observed to be open several millimeters to centimeters (or larger)	Aperture size is related to the velocity of water and some weaker bedrock types with large, open discontinuities could be erodible

Notes on use of Table:

1. Table is intended to provide guidance in addition to historical base rates of initiation of internal erosion. The neutral factors listed in the table would correspond to average base rates. Neutral factors do not imply a 50% probability. In general for a given Reclamation dam, there would be justification to select a probability of initiation of internal erosion higher than historical base rates if that dam was characterized by multiple “more likely” factors listed above; and conversely, there would be justification to select a probability of initiation of internal erosion lower than historical base rates if that dam was characterized by multiple “less likely” factors. Whether the estimated probability of initiation of internal erosion is higher, lower or near the historical base rate, the justification for the estimated probability must be documented. This table provides some guidance for that justification.
2. Some factors listed on the table apply to all internal erosion mechanisms (backward erosion piping, internal migration, scour, suffusion/suffosion) while some factors might only apply to one mechanism.
3. Some factors listed on the table are more critical to initiation of internal erosion than others. In general, more influential factors are listed towards the top of the table and less influential factors are listed towards the bottom.
4. For some factors, the “Less likely” column also includes factors that would make the probability of initiation “much less likely.”
5. Expert guidance is critical for interpreting observations at a dam and making judgments that relate performance of a specific dam to historical base rates of internal erosion.

References:

Fell, R. and C.F. Wan (2004), “Methods for Estimating the Probability of Failure of Embankment Dams by Internal Erosion and Piping in the Foundation and from Embankment to Foundation,” University of New South Wales, Sydney, Australia. UNICIV Report 436. January 2004.

“A Method for Estimating Probabilities of Failure of Embankment Dams due to Internal Erosion,” USACE Internal Erosion Toolbox, Best Practices Guidance Document, Final Draft, January 2010.

Table D-6-J-7.—Factors Influencing the Likelihood of Initiation of Internal Erosion of Embankment into Foundation

FACTORS INFLUENCING THE LIKELIHOOD OF INITIATION OF INTERNAL EROSION OF EMBANKMENT INTO FOUNDATION	DATE: JULY 2012
<p>The following factors from the table for <u>Internal Erosion Through an Embankment Dam</u> also apply to this category of <u>Internal Erosion of Embankment into Foundation</u>, as they relate primarily to the potential for seepage and internal erosion in the embankment portion of the seepage path:</p> <ul style="list-style-type: none"> Seepage Soil Erodibility Sinkholes or depressions Construction Impermeable zone width Foundation preparation of surface irregularities (foundation of the impermeable zone) and construction of first lifts on foundation Embankment zoning and overall geometry General quality of construction and quality control (also see construction as related to compaction above) Impermeable material characteristics Age of dam / length of service 	

In general, the factors from the table for Internal Erosion Through an Embankment Dam that relate to settlement and other causes of “defects” in an embankment were not included in this table given the improbability that an embankment defect would line up with a foundation defect.

However, if aligned defects are a consideration for a given embankment/foundation internal erosion failure mode being evaluated, consider the applicability of those factors as well.

FACTORS INFLUENCING THE LIKELIHOOD OF INITIATION OF INTERNAL EROSION OF EMBANKMENT INTO FOUNDATION				DATE: JULY 2012
Factor	Influence on Likelihood / Relative to Reclamation Historical Base Rates (see notes)			Comments
	Less Likely	Neutral	More Likely	
Foundation surface treatment measures	Dental concrete used to shape bedrock surfaces; slush grouting used to seal surface joints and fractures	Careful surface cleaning, but no dental concrete or slush grouting	No attention to foundation surface cleanup; no surface treatment measures	Careful attention to the treatment of foundation defects reduces the potential that seepage can attack the embankment/foundation contact
Initial fill placement on foundation	Plastic material placed on foundation surface; thin lifts; rolling with rubber tired equipment	Careful compaction, but no mention of more plastic soils	Thick lifts used; limited compaction; no mention of more plastic soils	The use of a plastic core material, perhaps placed wet of optimum, on the foundation surface reduces potential for erosion
Foundation grouting	Multiple row grout curtain in rock foundation Blanket grouting performed	Single row grout curtain in rock foundation; typical USBR grouting practices employed	No grouting of bedrock foundation that appears to have potential for seepage	Improperly designed and executed grouting programs can lead to windows for concentrated flow and high gradients near the top of the curtain Also consider the orientation of grout holes with respect to the discontinuities, as well as the robustness of closure criteria and the relative grout takes

FACTORS INFLUENCING THE LIKELIHOOD OF INITIATION OF INTERNAL EROSION OF EMBANKMENT INTO FOUNDATION				DATE: JULY 2012
Factor	Influence on Likelihood / Relative to Reclamation Historical Base Rates (see notes)			Comments
	Less Likely	Neutral	More Likely	
Presence and orientation of bedrock discontinuities	Minimal rock jointing and fracturing reported Much less likely if bedrock reported to be massive	Some bedrock discontinuities reported, but no widespread areas of fracturing/jointing	Embankment footprint contains large areas of significantly jointed or fractured bedrock, or contains prominent continuous joints or fracture patterns oriented upstream to downstream	The continuity of any bedrock feature such as a fault, joint, or fracture system is an important factor as to whether a seepage path will develop
Nature of bedrock discontinuities	Bedrock joints and fractures reported or observed to be tight/healed Discontinuity infillings are erodible	Bedrock joints or fractures reported or observed to be relatively tight, infilled, or open only a few millimeters	Bedrock joints and fractures reported or observed to be open several millimeters to centimeters or larger	Also consider the level of detailed documentation (or lack thereof) of the nature of the discontinuities
Presence of open-work foundation soils	No open-work foundation soils	Some coarse-grained deposits exist, but of questionable continuity and not particularly high porosity	Continuous layers of high porosity or open-work gravels and/or cobbles or talus	Also consider the level of detailed documentation (or lack thereof) of the nature of any open-work deposits
Presence of karstic features	Much less likely – no karstic features present	Karstic features are at depth or were recognized and properly treated	Features such as solution channels, brecciated zones, ancient chimneys and similar were present beneath dam footprint, with marginal treatment measures	

Notes on use of Table:

1. Table is intended to provide guidance in addition to historical base rates of initiation of internal erosion. The neutral factors listed in the table would correspond to average base rates. Neutral factors do not imply a 50% probability. In general for a given Reclamation dam, there would be justification to select a probability of initiation of internal erosion higher than historical base rates if that dam was characterized by multiple “more likely” factors listed above; and conversely, there would be justification to select a probability of initiation of internal erosion lower than historical base rates if that dam was characterized by multiple “less likely” factors. Whether the estimated probability of initiation of internal erosion is higher, lower or near the historical base rate, the justification for the estimated probability must be documented. This table provides some guidance for that justification.
2. Some factors listed on the table apply to all internal erosion mechanisms (backward erosion piping, internal migration, scour, suffusion/suffosion) while some factors might only apply to one mechanism.
3. Some factors listed on the table are more critical to initiation of internal erosion than others. In general, more influential factors are listed towards the top of the table and less influential factors are listed towards the bottom.
4. For some factors, the “Less likely” column also includes factors that would make the probability of initiation “much less likely.”
5. Expert guidance is critical for interpreting observations at a dam and making judgments that relate performance of a specific dam to historical base rates of internal erosion.

References:

Fell, R. and C.F. Wan (2004), “Methods for Estimating the Probability of Failure of Embankment Dams by Internal Erosion and Piping in the Foundation and from Embankment to Foundation,” University of New South Wales, Sydney, Australia. UNICIV Report 436. January 2004.

“A Method for Estimating Probabilities of Failure of Embankment Dams due to Internal Erosion,” USACE Internal Erosion Toolbox, Best Practices Guidance Document, Final Draft, January 2010.

Table D-6-J-8.—Factors Influencing the Likelihood of Initiation of Internal Erosion Into or Along a Conduit

FACTORS INFLUENCING THE LIKELIHOOD OF INITIATION OF INTERNAL EROSION INTO OR ALONG A CONDUIT				DATE: JULY 2012
Factor	Influence on Likelihood / Relative to Reclamation Historical Base Rates (see notes)			Comments
	Less Likely	Neutral	More Likely	
Voids below or adjacent to the conduit	Exploration programs (GPR, coring, etc.) confirm no voids present; no reason to believe voids might exist.	No exploration information. No reason to believe voids exist.	Exploration programs (GPR, coring, etc.) have confirmed the presence of voids under or adjacent to the conduit. Much more likely if voids are believed to be extensive and continuous. Judgment is required.	Conduit exploration programs are not typically conducted unless there are signs of adverse performance or potentially high risks have been identified.
Piezometric levels along the conduit	Piezometric levels along the conduit are measured or are estimated with confidence. Piezometric levels are within expected ranges for a well-performing structure with no local high gradients.	Piezometric levels along the conduit are unknown. No reason to believe that unusual piezometric levels exist.	Piezometric levels along the conduit are measured or are estimated with confidence. Piezometric levels indicate significant variations or unusual behavior (surging, episodic responses, response to conduit flows, etc.). Much more likely if piezometric levels indicate tailwater pressure near the upstream end of the conduit, indicating a very high local gradient and a continuous upstream to downstream defect.	Piezometric information along conduits is typically not available unless are signs of adverse performance or potentially high risks have been identified.
Seepage along conduit				
Presence of seepage	No seepage	Insignificant seepage; or seepage possible but unseen	Seepage significant	Lack of seepage being observed near the downstream end of the conduit would indicate a low probability for a concentrated leak along the conduit. Determination of the presence or absence of seepage may not be known with certainty. Episodic seepage could be an indicator that an internal erosion pathway is repeatedly opening and closing. Evidence of material transport in seepage flow would indicate near certainty that erosion is occurring.
Seepage fluctuations	Long-term steady rate of seepage unrelated to reservoir level or conduit flows	Seepage fluctuates with reservoir, but at a predictable rate	Seepage is increasing over time at the same reservoir level; or seepage is episodic or surging. Seepage can be correlated to conduit flows.	
Conduit foundation	Concrete conduit constructed on a rock foundation with little or no foundation preparation. Much less likely for a concrete conduit placed on a well-prepared rock foundation.	Conduit founded on well-graded compacted soil foundation or well-graded compacted fill.	Conduit founded on loose or poorly compacted soils. Much more likely if conduit founded on fine-grained, non-plastic erodible or dispersive materials.	Settlement of foundations can result in cracking of the conduit, which can lead to internal erosion into or along the conduit. Differential settlement between the conduit and other parts of the embankment can result in cracking and/or hydraulic fracturing.

FACTORS INFLUENCING THE LIKELIHOOD OF INITIATION OF INTERNAL EROSION INTO OR ALONG A CONDUIT				DATE: JULY 2012
Factor	Influence on Likelihood / Relative to Reclamation Historical Base Rates (see notes)			Comments
	Less Likely	Neutral	More Likely	
Cutoff collars / seepage collars (construction techniques and compaction are closely related to this factor).	No collars used.		Collars used with wide spacing Much more likely for closely spaced collars	Originally it was thought that providing seepage collars would force a longer seepage path and reduce the potential for concentrated leaks and internal erosion. However, it is difficult to achieve good compaction around collars and experience has shown that collars may not serve their intended design intent (FEMA 2005).
Conduit geometry / trench details	Conduit constructed in a trench in rock, backfilled with concrete.	Conduit constructed in a wide trench (in non-erodible soil or rock), at least 3 feet wider than the conduit on both sides, with side slopes at 1:1 or flatter.	Conduit constructed in a narrow trench in rock, with steep excavation slopes and backfilled with soil. Conduit constructed in a narrow trench in a soil foundation with steep excavation slopes and backfilled with concrete. Much more likely for conduit constructed in a narrow trench in rock with vertical sides and backfilled with soil.	Conduits constructed in narrow trenches can result in arching of stresses between stiffer elements (e.g. bedrock trench wall and the conduit) resulting in low minor principal stresses (possibly lower than hydrostatic pressures) and hydraulic fracturing.
Sinkholes or depressions on the embankment over the conduit alignment	No observations of sinkholes or depressions, including on upstream slope areas that are normally submerged.	Minor depressions on the upstream or downstream slopes that developed slowly and do not change over time.	Observations of sinkholes or depressions on the crest, upstream slope, or downstream slope that appear suddenly.	Sinkholes or depressions that form directly over a conduit are very likely related to the conduit and are a serious concern. Exploration and evaluation are needed to evaluate each site specific situation.
Conduit joints or cracks	High quality joints; water stops; no openings	High quality joints with some open up to 5 mm, but with water stops Very small cracks visible but not open, with no leakage.	Open joints or cracks. Much more likely for open joints or cracks with signs of erosion.	Width of joints or cracks should be compared to filter criteria (no erosion, excessive erosion, continuing erosion). This factor is related to both initiation and continuation because in some cases, a crack is the cause of initiation of erosion.
Conduit structure exterior sidewall slope	Exterior constructed with a batter of 10V:1H or flatter.		Exterior constructed vertically. Much more likely if conduit constructed with overhangs.	If the conduit exterior sidewalls are constructed vertically, it may be difficult to compact against the structure to achieve a good contact between the embankment and the structure. Loose (or less dense) soils adjacent to the structure may be

FACTORS INFLUENCING THE LIKELIHOOD OF INITIATION OF INTERNAL EROSION INTO OR ALONG A CONDUIT				DATE: JULY 2012
Factor	Influence on Likelihood / Relative to Reclamation Historical Base Rates (see notes)			Comments
	Less Likely	Neutral	More Likely	
				subject to low stresses, arching and hydraulic fracturing.
Hydraulic operation and control	Upstream control of water into a pressurized pipe within a concrete conduit. Inspections performed annually.	Upstream control of water into a non-pressurized conduit adjacent to the embankment. Intermediate control of water with an interior gate chamber, pressurized conduit upstream of gate chamber adjacent to embankment, non-pressurized conduit downstream of gate chamber.	Downstream control of water, pressurized conduit adjacent to embankment; high velocity flows.	Whenever a pressurized conduit is adjacent to embankment soils, the possibility exists that a defect in the conduit could expose the embankment soil to reservoir pressures. Reclamation does not have pressurized conduits in the downstream half of the embankment.
First filling	Slow first filling has been accomplished; conduit is exposed to normal maximum reservoir elevation almost annually.		First filling not yet accomplished. Conduit has never been exposed to reservoir elevation near the normal maximum. Much more likely if a rapid first filling is likely (and cannot be avoided).	A rapid first filling may not allow slow wetting of earthfill; may not allow re-distribution of stresses. Cracks and hydraulic fractures could form if a rapid filling does not allow soils to adjust and compress against the conduit.
Settlement	Conduit founded on dense materials, little or no settlement,	Some settlement but conduit has good design details	Large settlement, no design details to accommodate.	Survey inside conduits is not always possible; signs of settlement include concrete cracking and ponding of water on the conduit floor.
Connection to other structures	No other structures in the impervious zone	Good connection details between conduit and other structures within the impervious zone (e.g. central shaft or interior chamber).	Poor connection details between conduit and other structures within the impervious zone (e.g. central shaft or interior chamber).	Poor connection details between the horizontal conduit and other structures could lead to localized settlement, cracking or low stress zones.
Conduit exterior finish	Smooth (steel or formed concrete)	Rough	Corrugated exterior	Good contact between the structure and the embankment fill is difficult to achieve if there are corrugations, or similar irregularities.
Conduit type	Concrete-encased steel conduit Concrete case in situ	Concrete-encased cast iron Concrete precast	Steel or cast iron, not encased. Much more likely for round conduits (not encased), masonry, brick, corrugated steel.	This factor is low on this table because most Reclamation conduits are concrete. However, for non-Reclamation dams, this would be a significant factor to consider.
Conduit corrosion	Concrete conduit; non-corrodible conduit; new steel with corrosion protection	Cast iron (< 20 years); steel (< 10 years); corrugated metal (< 5 years).	Old cast iron (> 60 years); old steel (> 30 years); old corrugated metal (> 10 years).	This factor is low on this table because most Reclamation conduits are concrete. However, for non-Reclamation dams, this would be a significant factor to consider.

FACTORS INFLUENCING THE LIKELIHOOD OF INITIATION OF INTERNAL EROSION INTO OR ALONG A CONDUIT				DATE: JULY 2012
Factor	Influence on Likelihood / Relative to Reclamation Historical Base Rates (see notes)			Comments
	Less Likely	Neutral	More Likely	
			Much more likely for old corroded cast iron or corroded steel.	

Notes on use of Table:

1. The factors on this table are specifically for potential failure modes related to internal erosion into or along a conduit. Similar factors would apply to any potential failure mode involving an upstream to downstream penetration (e.g. spillway wall, instrumentation trench, etc.). Many other factors listed in the “Initiation of Internal Erosion through the Embankment” table are also relevant (e.g. erodibility, compaction of fill, construction factors, etc.) and should be considered when evaluating initiation of internal erosion into or along a conduit.
2. Table is intended to provide guidance in addition to historical base rates of initiation of internal erosion. The neutral factors listed in the table would correspond to average base rates. Neutral factors do not imply a 50% probability. In general for a given Reclamation dam, there would be justification to select a probability of initiation of internal erosion higher than historical base rates if that dam was characterized by multiple “more likely” factors listed above; and conversely, there would be justification to select a probability of initiation of internal erosion lower than historical base rates if that dam was characterized by multiple “less likely” factors. Whether the estimated probability of initiation of internal erosion is higher, lower or at the historical base rate, the justification for the estimated probability must be documented. This table provides some guidance for that justification.
3. Some factors listed on the table apply to all internal erosion mechanisms (backward erosion piping, internal migration, scour, suffusion/suffosion) while some factors might only apply to one mechanism.
4. Some factors listed on the table are more critical to initiation of internal erosion along a conduit than others. In general, more influential factors are listed towards the top of the table and less influential factors are listed towards the bottom.
5. Expert guidance is critical for interpreting observations at a dam and making judgments that relate performance of a specific dam to historical base rates of internal erosion.

References:

Technical Manual: Conduits through Embankment Dams, Best Practices for Design, Construction, Problem Identification and Evaluation, Inspection, Maintenance, Renovation and Repair, FEMA 484, September 2005.

Draft Risk Analysis Methodology Appendix E (2000), Estimating Risk of Internal Erosion and Material Transport Failure Modes for Embankment Dams, version 2.4, Bureau of Reclamation, Technical Service Center, Denver, CO. August 18, 2000. (This document was never finalized; it was superseded in 2008 by Dam Safety Risk Analysis Best Practices Training Manual, Chapter 24.)

Fell, R., C.F. Wan, and M. Foster (2004), “Progress Report on Methods for Estimating the Probability of Failure of Embankment Dams by Internal Erosion and Piping,” University of New South Wales, Sydney, Australia. UNICIV Report 428. 2004.

Table D-6-J-9.—Factors Influencing the Likelihood of Initiation of Internal Erosion into Drains

FACTORS INFLUENCING THE LIKELIHOOD OF INITIATION OF INTERNAL EROSION INTO DRAINS				DATE: JULY 2012
Factor	Influence on Likelihood / Relative to Reclamation Historical Base Rates (see notes)			Comments
	Less Likely	Neutral	More Likely	
Material transport	No indications of sediment in seepage or catchment basis	No mechanism to monitor sediment transport (typically not possible in underdrains)	Sediment noted in pipe, catchment basins, or seepage flows	Evidence of material transport in seepage flow would indicate near certainty that erosion is occurring.
Toe Drains: Seepage				
Presence of seepage	No seepage	Insignificant seepage; or within expected ranges	Seepage significant	Lack of seepage may indicate drain above ground water surface. Episodic seepage could be an indicator that an internal erosion pathway is repeatedly opening and closing.
Seepage fluctuations	Long-term steady rate of seepage unrelated to reservoir level	Seepage fluctuates with reservoir, but at a predictable rate	Seepage is increasing over time at the same reservoir level; or seepage is episodic or surging.	
Drain joints or cracks	No cracks or open joints noted	Very small cracks visible but not open, with no leakage.	Open joints or cracks. Much more likely for open joints or cracks with signs of erosion.	Width of joints or cracks should be compared to filter criteria (no erosion, excessive erosion, continuing erosion). This factor is related to both initiation and continuation because in some cases, a crack is the cause of initiation of erosion.
Pipe characteristics	Pipe consists of new materials (see Report DSO-09-01)	Clay or cement pipe laid with open joints Single wall HDPE pipe Corrugated metal pipe(CMP) and asbestos bonded CMP	Age may indicate degree or deterioration or corrosion.	Typical Reclamation dams are built with “sewer pipe laid with open joints” All pipe types are subject to deterioration.
Filter and drain envelope characteristics	Designed two-stage filter and drain envelope meeting current filter criteria Adequate width of filter and drain envelope	Single stage envelope. Minimal widths of filter and drain envelope	No sand or gravel envelope around drain	Evaluate filter and drain envelope for no erosion, some erosion, and continuing erosion criteria
Sinkholes or depressions on the embankment or foundation over the drain alignment	No observations of sinkholes or depressions.	Minor depressions over or near the drain alignment that developed slowly and do not change over time.	Observations of sinkholes or depressions over or near the drain alignment that appear suddenly.	Sinkholes or depressions that form directly over a drain are very likely related to the drain. The location of the sinkhole is a key factor in the seriousness of the concern. Inspection, exploration, and/or evaluation are needed to evaluate each site specific situation.
Structure Underdrains	Structure founded on non-erodible rock foundation.	Structure founded on well-graded compacted soil foundation or well-graded compacted fill.	Structure founded on loose or poorly compacted soils. Much more likely if drain founded on fine-	Surcharge pressures from outflows can cause materials surrounding pipe to be drawn into drains.

FACTORS INFLUENCING THE LIKELIHOOD OF INITIATION OF INTERNAL EROSION INTO DRAINS				DATE: JULY 2012
Factor	Influence on Likelihood / Relative to Reclamation Historical Base Rates (see notes)			Comments
	Less Likely	Neutral	More Likely	
		Structure founded on soft rock.	grained, non-plastic erodible or dispersive materials.	Location of outfall may be a consideration.
Inspections	Inspections conducted over large percentage of pipe and no issues identified	Inspections only possible for short portion of pipe, but no issues identified Inspections not possible	Inspections possible and identify cracks, pipe failure, sags in pipe, plugging, root intrusion, deformation, etc.	Poor pipe condition does not automatically mean there is a high probability of an unfiltered exit. Plugging may improve conditions by raising tailwater and lowering gradient. Evaluation of inspection data should consider site specific conditions and potential failure modes. See [1] for more information on inspections of drains.
Voids below or adjacent to the pipe	Exploration programs (GPR, coring, etc.) confirm no voids present; no reason to believe voids might exist.	No exploration information. No reason to believe voids exist.	Exploration programs (GPR, coring, etc.) have confirmed the presence of voids under or adjacent to the conduit. Much more likely if voids are believed to be extensive and continuous. Judgment is required.	Exploration programs are not typically conducted unless there are signs of adverse performance or potentially high risks have been identified.
Location of toe drain		Drain located near toe of dam beneath impervious zones	Drain located more upstream than typical (beneath central portion of the dam).	The further upstream the drain is located, the shorter the seepage path and potentially higher gradients.

Notes on use of Table:

1. The factors on this table are specifically for potential failure modes related to internal erosion into a drain. Many other factors listed in the “Initiation of Internal Erosion through the Embankment” table are also relevant (e.g. erodibility, compaction of fill, construction factors, etc.) and should be considered when evaluating initiation of internal erosion into a drain.
2. Table is intended to provide guidance in addition to historical base rates of initiation of internal erosion. The neutral factors listed in the table would correspond to average base rates. Neutral factors do not imply a 50% probability. In general for a given Reclamation dam, there would be justification to select a probability of initiation of internal erosion higher than historical base rates if that dam was characterized by multiple “more likely” factors listed above; and conversely, there would be justification to select a probability of initiation of internal erosion lower than historical base rates if that dam was characterized by multiple “less likely” factors. Whether the estimated probability of initiation of internal erosion is higher, lower or at the historical base rate, the justification for the estimated probability must be documented. This table provides some guidance for that justification.
3. Some factors listed on the table apply to all internal erosion mechanisms (backward erosion piping, internal migration, scour, suffusion/suffosion) while some factors might only apply to one mechanism.
4. Some factors listed on the table are more critical to initiation of internal erosion into a drain than others. In general, more influential factors are listed towards the top of the table and less influential factors are listed towards the bottom.
5. Expert guidance is critical for interpreting observations at a dam and making judgments that relate performance of a specific dam to historical base rates of internal erosion.

References:

[1] Guidelines for Embankment Drain Inspections, Evaluation and Follow-Up Activities, Bureau of Reclamation, Denver, CO, July 2005.

[2] Drainage for Dams and Associated Structures, Bureau of Reclamation, Denver, CO, 2004.

[3] Draft Risk Analysis Methodology Appendix E (2000), Estimating Risk of Internal Erosion and Material Transport Failure Modes for Embankment Dams, version 2.4, Bureau of Reclamation, Technical Service Center, Denver, CO. August 18, 2000. (This document was never finalized; it was superseded in 2008 by Dam Safety Risk Analysis Best Practices Training Manual, Chapter 24.)

[4] Fell, R., C.F. Wan, and M. Foster (2004), "Progress Report on Methods for Estimating the Probability of Failure of Embankment Dams by Internal Erosion and Piping," University of New South Wales, Sydney, Australia. UNICIV Report 428. 2004.